

ABL



SWITCHING DEVICES

IN COMPLIANCE WITH UL 489, UL 508 AND UL 1077 · MAY 2017



THE ORIGINAL. SINCE 1933.

SWITCHING DEVICES

UL 489, UL 508 AND UL 1077

ABL SWITCHING DEVICES WORLDWIDE	4
--	---

THE WINNING FEATURES OF ABL SWITCHING DEVICES	6
--	---

UL 489, UL 508 AND UL 1077 OVERVIEW	8
--	---

WIRING DIAGRAM European and american standard	10
---	----

SWITCHING DEVICES ACC. TO UL 489 AND CSA-22.2 NO. 5-09	12
---	----

Circuit Breaker UL, Product Range AC	14
Produktreihe DL, Product Range DC	16
Accessories	17
Busbars	19
Technical data	21

SWITCHING DEVICES ACC. TO UL 508 AND CSA-22.2 NO. 14	26
---	----

Manual Motor Controller UM	
Product Range UM	28
Accessories	32
Busbars	34
Technical Data	36

Manual Motor Controller MA	
Product Range MA..UM	44
Accessories	48
Technical Data	50

Manual Motor Controller MS	
Product Range MS	54
Accessories	56
Busbars	59
Technical Data	60

SWITCHING DEVICES ACC. TO UL 1077 AND CSA-22.2 NO. 235	64
---	----

Supplementary Protector UR	66
Accessories	68
Technical data	70

ITEM NUMBER DIRECTORY	73
------------------------------	----

SWITCHING DEVICES FOR THE WORLD

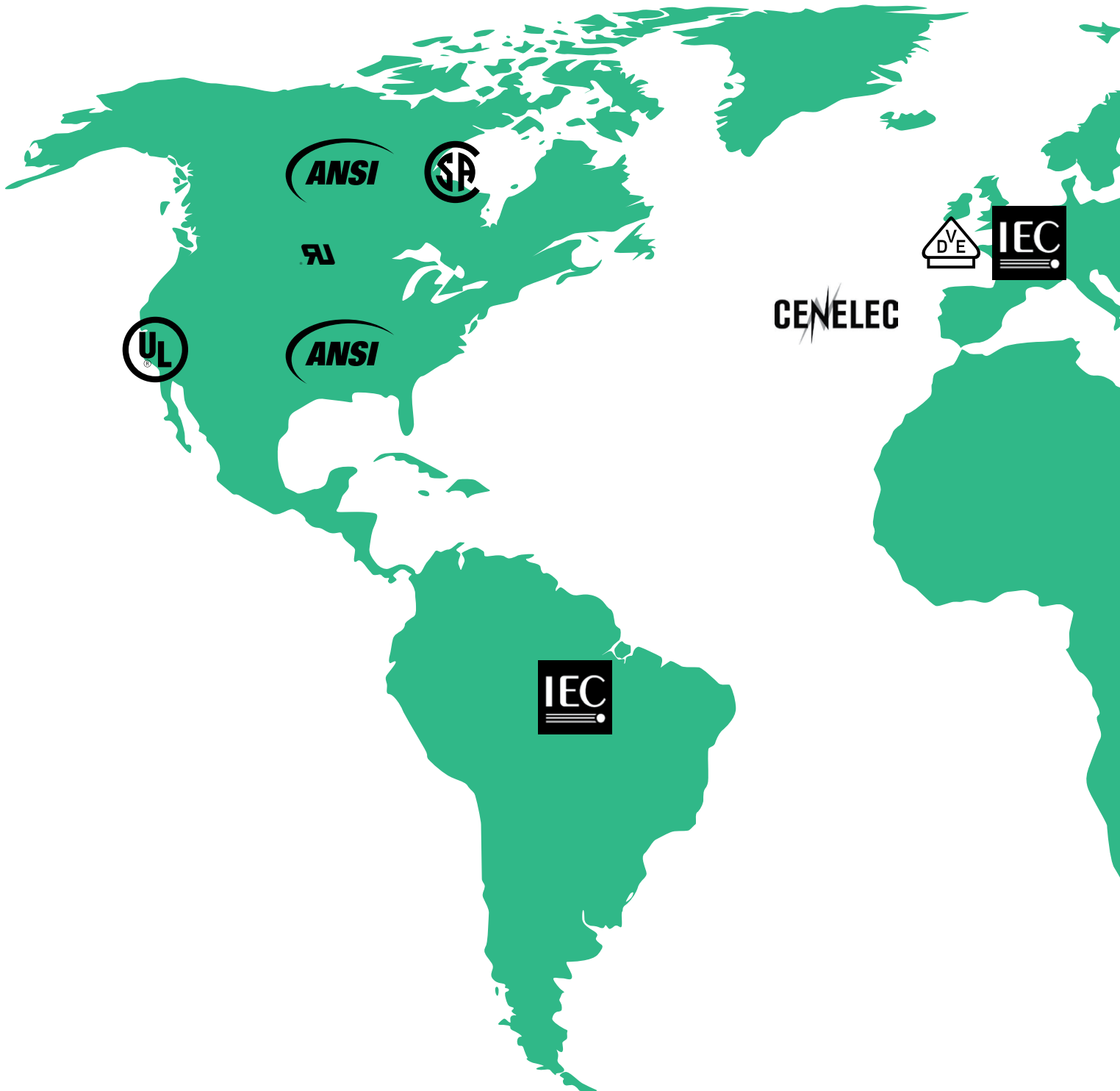

Since 1933, we develop and produce switching devices for the North American market. The approvals in accordance with UL and IEC standards offer you the opportunity to standardize your machinery and make you independent of the location where the equipment will later be used.

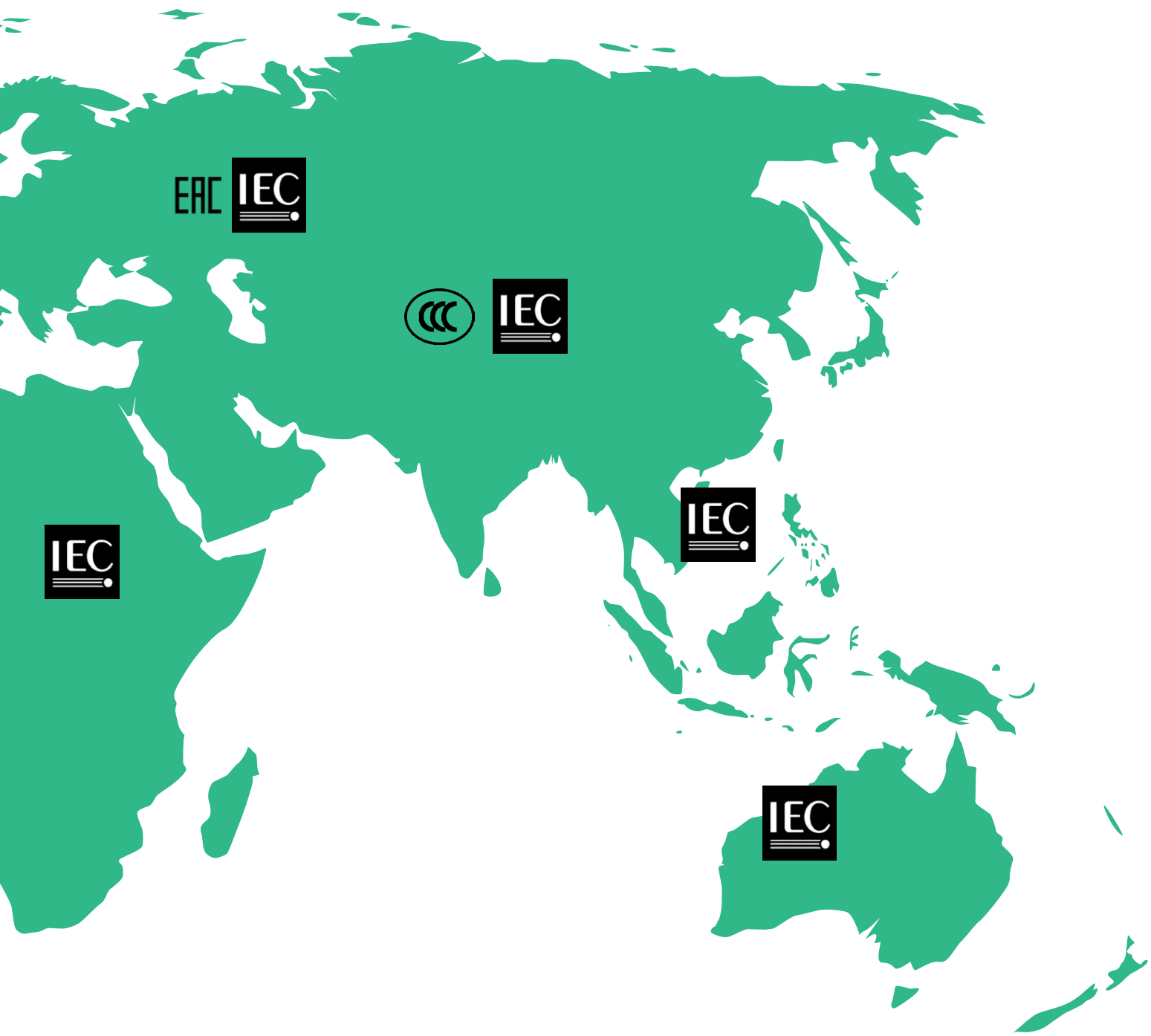

EAC IEC

CCC IEC

IEC

IEC

IEC

THE WINNING FEATURES OF ABL SURSUM SWITCHING DEVICES

1 FUNCTIONAL FORM

- Contemporary design
- User-friendly ergonomics
- Intuitive product coding
- Clearly marked ON/OFF positions

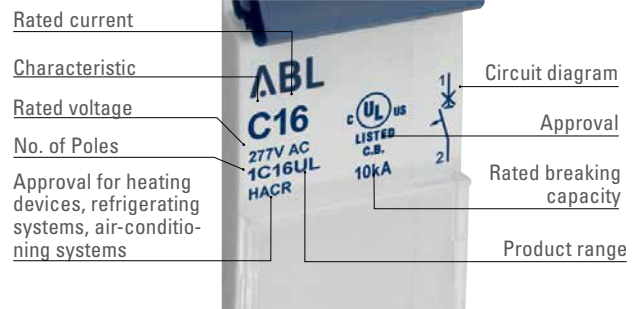

2 COMPACT DESIGN OFFERING MAXIMUM WIRING SPACE

- At 105 mm installation height one of the smallest UL 489 compliant circuit breakers available
- At 89.3 mm the smallest UL 508 manual motor controller available
- An equally space-saving 89.3 mm for the UL 1077 supplementary protector

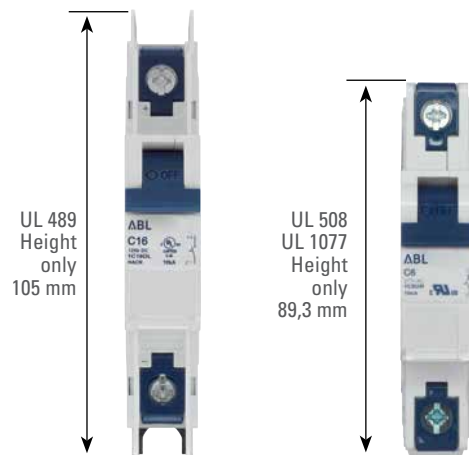

3 UL SWITCHING DEVICES

in a consistent and contemporary design



4 EXTENSIVE APPLICATION POSSIBILITIES

- Three separate product ranges for circuit protection, manual motor control and supplementary protection applications
- AC and DC versions available
- European and North American standard tripping characteristics featuring the widest possible range of nominal ratings
- **UL 489**
AC, 0.3 - 63 A, 1-pole/2-pole/3-pole compliant with UL 489 and CSA-22.2 No. 5-09
UL product range tripping types AC: B, C, D, Z
DC, 0.3 - 63 A, 1-pole/2-pole
DL product range type C
- **UL 508**
0.3 - 63 A, 1-pole/2-pole/3-pole compliant with UL 508 and CSA-22.2 No.14
UM product range, B, C, D, G, E and Z
types B, C and D up to 25 A also compliant with IEC 60898-1,
DIN EN 60898-1, VDE 0641-11
- **UL 1077**
0.5 - 63 A, 1-pole/2-pole/3-pole compliant with the UL 1077 and CSA-22.2 No.235
UR product range types B, C, and D

5 COMPLETE PRODUCT SYSTEM

- Full range of accessories for UL 489 Circuit Breakers
- Common line of accessories for the UL 508 and UL 1077 Product lines
- Full range of auxiliary switches
- Shunt trip and neutral pole can be added left or right



6 PROFESSIONAL LABELING SYSTEM

- with marking window
- Blank perforated labels available for one pole, two pole and three pole windows for convenient circuit indication



7 STANDARD DUAL CONNECTION METHOD

for all three product ranges

- Box clamp terminal (line load reversible)
- for solid and flexible conductors
Top: 18-3AWG (1.0 mm² - 25 mm²)
Bottom: 18-2AWG (1.0 mm² - 35 mm²)
- for busbars



Unique connecting system for the convenient connection of all known cable lugs such as ring or forked cable lugs and pin terminals.

OVERVIEW

- Extensive range of possible applications
- Three product ranges for circuit protection, manual motor control and supplementary protection applications
- AC and DC versions available
- European and North American standard tripping characteristics with the widest possible range of nominal ratings



BUSBARS AVAILABLE FOR UL 489 DEVICE

BUSBARS AVAILABLE FOR UL 508 AND UL 1077 DEVICE

Product Range	UL			DL		UM **						UR **	
Standards	UL 489					UL 508						UL 1077	
UL File	E 329510					E 137938						E 137915	
Rated voltage	240 V AC	277 V AC	480 V AC	125 V DC	250 V DC	277 V AC	480 V AC	42 V DC	80 V DC	24 V DC	60 V DC	277 V AC	480 V AC
Number of poles	1 / 1+N* / 2 / 3 / 3+N*	1 / 1+N*	2 / 3 / 3+N*	1	2	1 / 1+N*	2 / 3 / 3+N*	1	2	1	2	1 / 1+N*	2 / 3 / 3+N*
B - Characteristic						1-63 A	1-63 A	1-25 A	1-25 A	30-63 A	30-63 A	1-63 A	1-63 A
C - Characteristic	40-63 A	0.3-32 A	0.3-32 A	0.3-63 A	0.3-63 A	0.3-63 A	0.3-63 A	0.3-25 A	0.3-25 A	30-63 A	30-63 A	0.3-63 A	0.3-63 A
D - Characteristic	40-63 A	0.3-32 A	0.3-32 A			0.3-63 A	0.3-63 A	0.3-25 A	0.3-25 A	30-63 A	30-63 A	0.3-63 A	0.3-63 A
E - Characteristic						0.3-63 A	0.3-63 A	0.3-25 A	0.3-25 A	30-63 A	30-63 A		
G - Characteristic						0.3-63 A	0.3-63 A	0.3-25 A	0.3-25 A	30-63 A	30-63 A		
Z - Characteristic						0.3-50 A	0.3-50 A	0.3-25 A	0.3-25 A	30-50 A	30-50 A		

* N pole to be mounted separately
 ** UL approval up to 60 A

FULL RANGE OF ACCESSORIES FOR UL 489, UL 508 AND UL 1077

- Auxiliary switches
- Shunt trip and Neutral pole can be added on the left or right

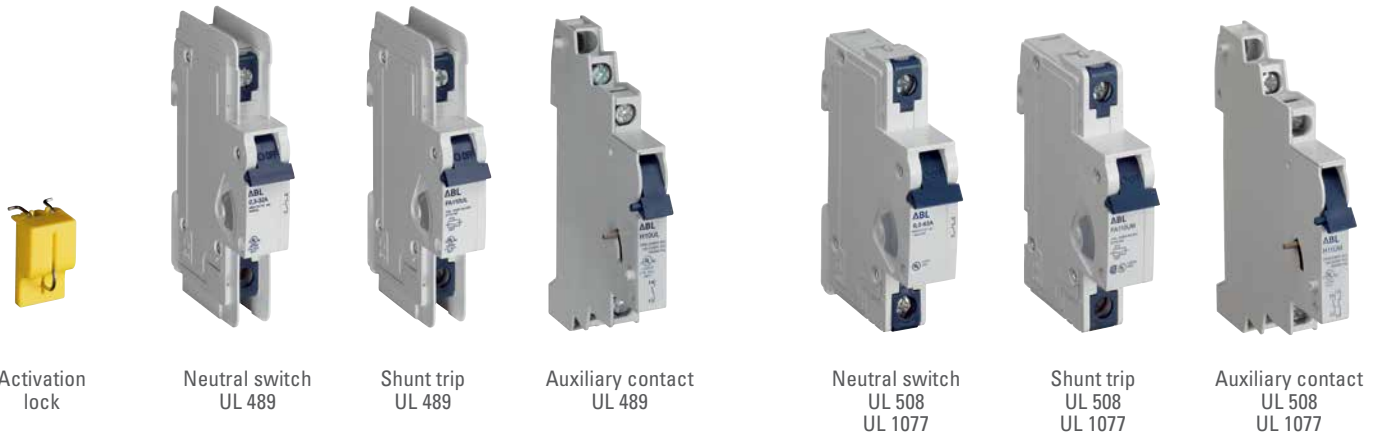

	UL 489 LISTED CIRCUIT BREAKERS AC DISTRIBUTION EQUIPMENT	UL 508 LISTED MANUAL MOTOR CONTROLLER INDUSTRIAL CONTROL EQUIPMENT	UL 1077 SUPPLEMENTARY PROTECTOR
--	--	--	------------------------------------

Main Characteristics			
Listed component	•	•	
Recognized components for supplementary protection only			•
Field wiring	•	•	
Factory wiring	•	•	•
Feeder circuit protection	•		
Branch circuit protection	•		
Control Circuits	•	•	•

Functions			
Short circuit protection	•		
Switching function	•	•	
Disconnect function	•	•	
Overload protection	•	•	•

Applications			
Heaters, coolers, -air conditioning (HACR approval)	•		
Protection of outlets	•		
Transformers	•		
Motor protection	•	•	
Control transformers	•	•	•
Inductive loads	•	•	•
Appliances, Business Equipment	•	•	•
General lamps	•	•	•
Fuorescent lamps	•	•	•

WIRING DIAGRAM WITH SWITCHING DEVICES ACC. TO UL 489, UL 508 AND UL 1077

European standard

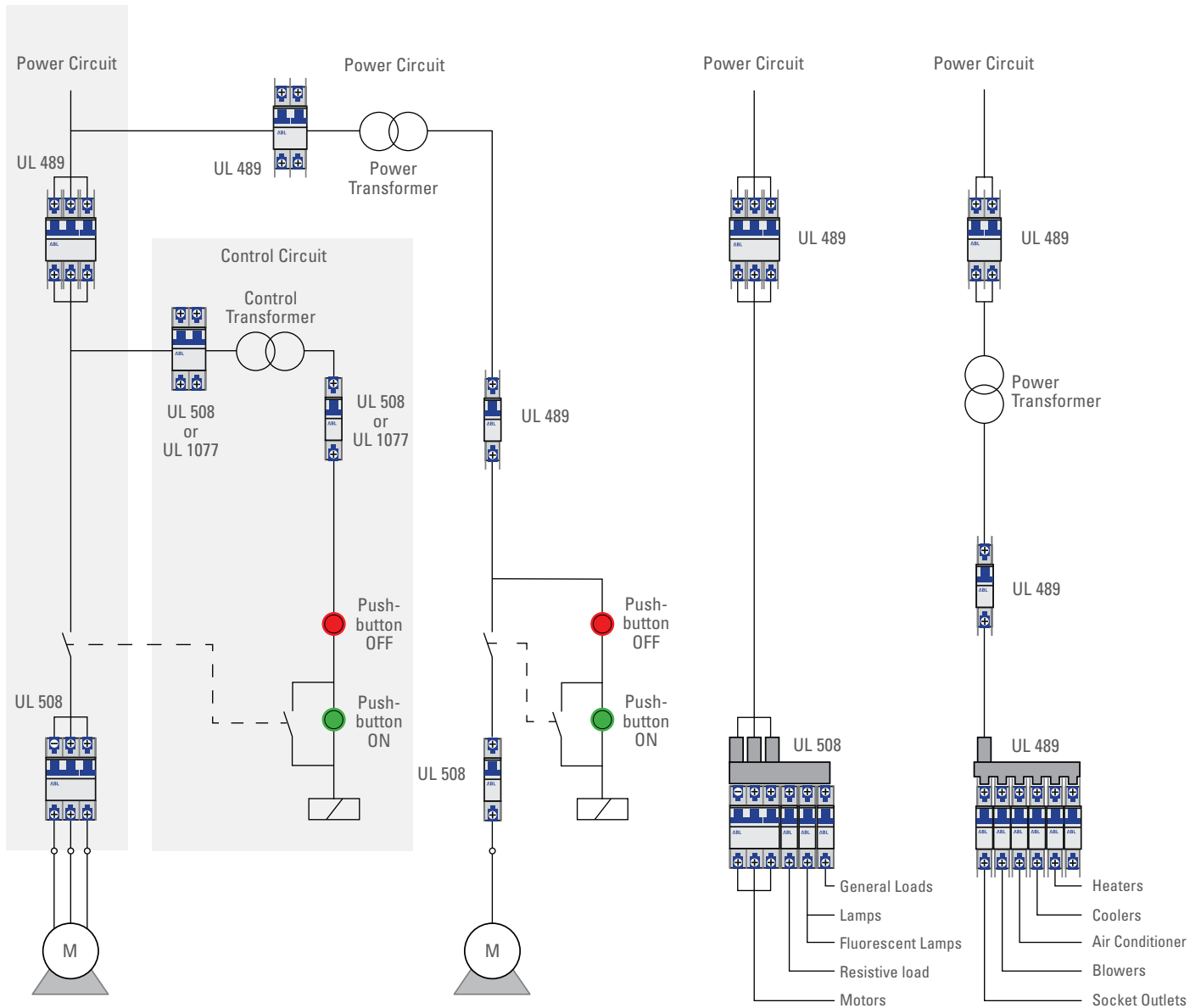

Rating of main branch circuit protector according to table 430.52 in NEC®

• Dual Element (Time Delay) Fuse

Maximum fuse = largest motor FLA x 175 %
+ FLA of all other motors and general loads in group

• Inverse Time Breaker

Maximum circuit breaker = largest motor FLA x 250 %
+ FLA of all other motors and general loads in group
(for other fuse/breaker types see table 430.52)

WIRING DIAGRAM WITH SWITCHING DEVICES ACC. TO UL 489, UL 508 AND UL 1077

North American standard

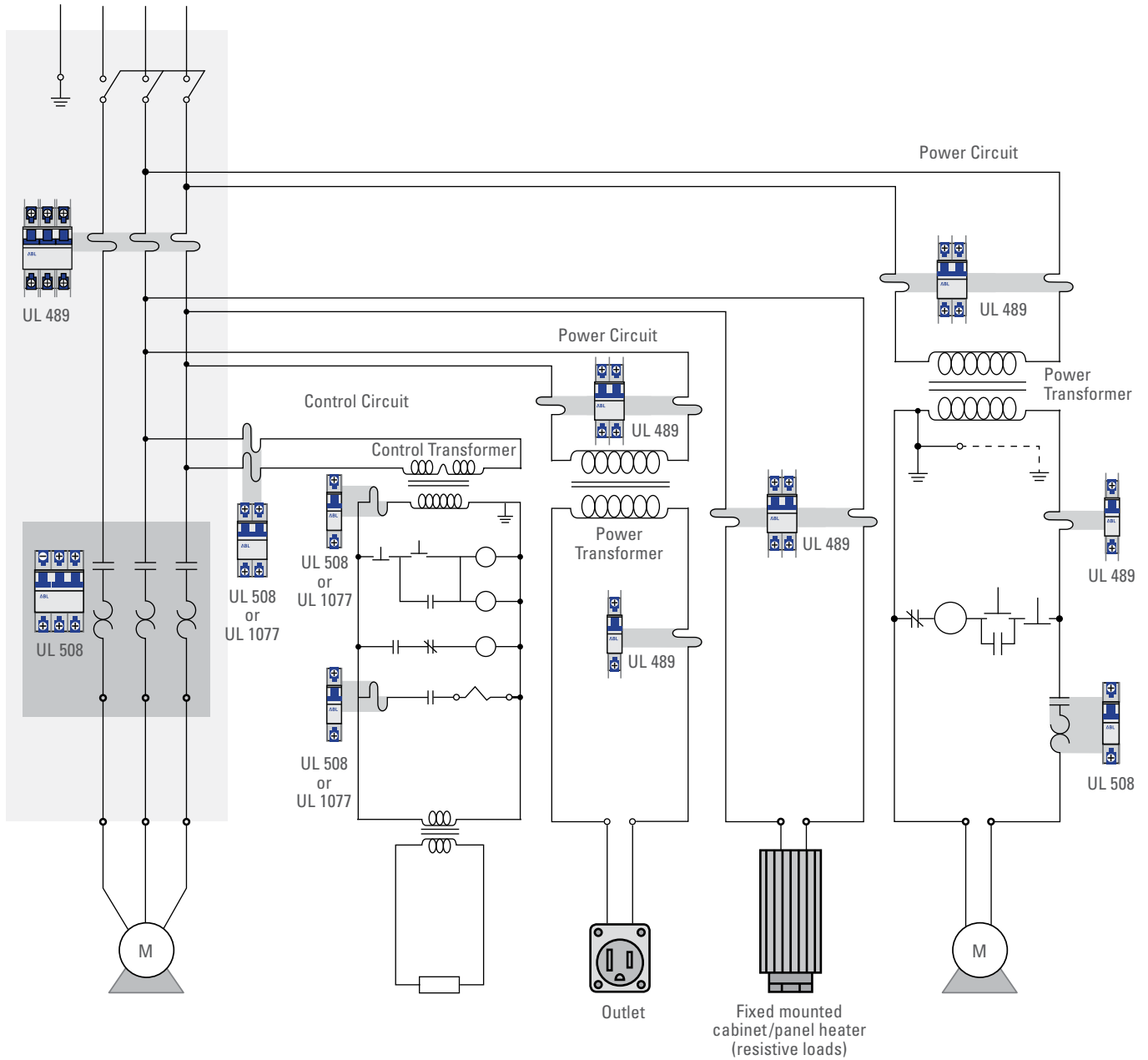

Rating of main branch circuit protector according to table 430.52 in NEC®

• Dual Element (Time Delay) Fuse

Maximum fuse = largest motor FLA x 175 %
+ FLA of all other motors and general loads in group

• Inverse Time Breaker

Maximum circuit breaker = largest motor FLA x 250 %
+ FLA of all other motors and general loads in group
(for other fuse/breaker types see table 430.52)



UL 489

SWITCHING DEVICES IN COMPLIANCE WITH UL 489 AND CSA-22.2 NO. 5-09

Compared to traditional fuse installation, the UL 489 and CSA-22.2 No.5-09 compliant circuit breakers listed here assist with the complex task of selecting correct types and characteristics and offer a less bulky installation solution.

Our range of miniature, molded-case circuit breakers – in combination with our accessories for factory or on-site installation – offers enhanced control and monitoring capabilities. Installation kits include all parts and instructions to make your on-site job easy.

We supply UL 489 compliant 1, 2 and 3-pole-type switching devices from 0.3 to 63 Ampere and with type C and D characteristics.

Attachments such as neutral switches, auxiliary contacts and shunt trips are also available for this system. All accessories for modern busbar installations are available in compliance with the current UL standards.

SWITCHING DEVICES LISTED CIRCUIT BREAKERS AC

according to UL 489 and CSA-22.2 No. 5-09 · UL Product Range, AC Version, C and D Characteristics



FILE E 329510



RATED CURRENT I _N A	RATED VOLTAGE VOLT AC	CHARACTERISTIC *		WEIGHT G / EACH	PACKING UNIT
		C ITEM NO.	D ITEM NO.		

1-pole					
0.3	277/480	1C03UL	1D03UL	155	12
0.5	277/480	1C05UL	1D05UL	155	12
1	277/480	1C1UL	1D1UL	155	12
1.6	277/480	1C1.6UL	1D1.6UL	155	12
2	277/480	1C2UL	1D2UL	155	12
3	277/480	1C3UL	1D3UL	155	12
4	277/480	1C4UL	1D4UL	155	12
5	277/480	1C5UL	1D5UL	155	12
6	277/480	1C6UL	1D6UL	155	12
8	277/480	1C8UL	1D8UL	155	12
10	277/480	1C10UL	1D10UL	155	12
12	277/480	1C12UL	1D12UL	155	12
13	277/480	1C13UL	1D13UL	155	12
15	277/480	1C15UL	1D15UL	155	12
16	277/480	1C16UL	1D16UL	155	12
20	277/480	1C20UL	1D20UL	155	12
25	277/480	1C25UL	1D25UL	155	12
30	277/480	1C30UL	1D30UL	155	12
32	277/480	1C32UL	1D32UL	155	12
40	240	1C40UL	1D40UL	155	12
50	240	1C50UL	1D50UL	155	12
60	240	1C60UL	1D60UL	155	12
63	240	1C63UL	1D63UL	155	12



2-pole					
0.3	277/480	2C03UL	2D03UL	310	6
0.5	277/480	2C05UL	2D05UL	310	6
1	277/480	2C1UL	2D1UL	310	6
1.6	277/480	2C1.6UL	2D1.6UL	310	6
2	277/480	2C2UL	2D2UL	310	6
3	277/480	2C3UL	2D3UL	310	6
4	277/480	2C4UL	2D4UL	310	6
5	277/480	2C5UL	2D5UL	310	6
6	277/480	2C6UL	2D6UL	310	6
8	277/480	2C8UL	2D8UL	310	6
10	277/480	2C10UL	2D10UL	310	6
12	277/480	2C12UL	2D12UL	310	6
13	277/480	2C13UL	2D13UL	310	6
15	277/480	2C15UL	2D15UL	310	6
16	277/480	2C16UL	2D16UL	310	6
20	277/480	2C20UL	2D20UL	310	6
25	277/480	2C25UL	2D25UL	310	6
30	277/480	2C30UL	2D30UL	310	6
32	277/480	2C32UL	2D32UL	310	6
40	240	2C40UL	2D40UL	310	6
50	240	2C50UL	2D50UL	310	6
60	240	2C60UL	2D60UL	310	6
63	240	2C63UL	2D63UL	310	6

* Also available in B and Z characteristics on request

SWITCHING DEVICES LISTED CIRCUIT BREAKERS AC

according to UL 489 and CSA-22.2 No. 5-09 · UL Product Range, AC Version, C and D Characteristics



FILE E 329510



RATED CURRENT I_N A	RATED VOLTAGE VOLT AC	CHARAKTERISTIC *		WEIGHT G / EACH	PACKING UNIT
		C ITEM NO.	D ITEM NO.		
3-pole					
0.3	277/480	3C03UL	3D03UL	415	4
0.5	277/480	3C05UL	3D05UL	415	4
1	277/480	3C1UL	3D1UL	415	4
1.6	277/480	3C1.6UL	3D1.6UL	415	4
2	277/480	3C2UL	3D2UL	415	4
3	277/480	3C3UL	3D3UL	415	4
4	277/480	3C4UL	3D4UL	415	4
5	277/480	3C5UL	3D5UL	415	4
6	277/480	3C6UL	3D6UL	415	4
8	277/480	3C8UL	3D8UL	415	4
10	277/480	3C10UL	3D10UL	415	4
12	277/480	3C12UL	3D12UL	415	4
13	277/480	3C13UL	3D13UL	415	4
15	277/480	3C15UL	3D15UL	415	4
16	277/480	3C16UL	3D16UL	415	4
20	277/480	3C20UL	3D20UL	415	4
25	277/480	3C25UL	3D25UL	415	4
30	277/480	3C30UL	3D30UL	415	4
32	277/480	3C32UL	3D32UL	415	4
40	240	3C40UL	3D40UL	415	4
50	240	3C50UL	3D50UL	415	4
60	240	3C60UL	3D60UL	415	4
63	240	3C63UL	3D63UL	415	4

* Also available in B and Z characteristics on request



FILE E 335632



RATED CURRENT I_N A	RATED VOLTAGE VOLT AC	ELECTROMAGNETIC TEST CURRENTS *		ITEM NO.	WEIGHT G / EACH	PACKING UNIT
		NOT TRIPPING I_A	TRIPPING I_A			
Neutral switch – for mounting instructions please consult page 9						
0.3 - 32	277/480	400	700	N32UL	165	6
40 - 63	240	630	1000	N63UL	165	6

* additional electromagnetic protection

SWITCHING DEVICES LISTED CIRCUIT BREAKERS DC

according to UL 489 and CSA-22.2 No. 5-09 · DL Product Range, DC Version, C Characteristics



FILE E 329510

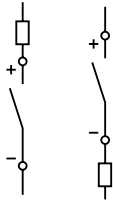

RATED CURRENT I_N A	RATED VOLTAGE VOLT DC	CHARAKTERISTIC C ITEM NO.	WEIGHT G / EACH	PACKING UNIT
--------------------------	--------------------------	---------------------------------	--------------------	-----------------

1-pole				
0.3	125	1C03DL	165	12
0.5	125	1C05DL	165	12
1	125	1C1DL	165	12
1.6	125	1C1.6DL	165	12
2	125	1C2DL	165	12
3	125	1C3DL	165	12
4	125	1C4DL	165	12
5	125	1C5DL	165	12
6	125	1C6DL	165	12
8	125	1C8DL	165	12
10	125	1C10DL	165	12
12	125	1C12DL	165	12
13	125	1C13DL	165	12
15	125	1C15DL	165	12
16	125	1C16DL	165	12
20	125	1C20DL	165	12
25	125	1C25DL	165	12
30	125	1C30DL	165	12
32	125	1C32DL	165	12
40	125	1C40DL	165	12
50	125	1C50DL	165	12
60	125	1C60DL	165	12
63	125	1C63DL	165	12

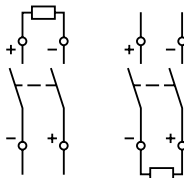

2-pole				
0.3	250	2C03DL	330	6
0.5	250	2C05DL	330	6
1	250	2C1DL	330	6
1.6	250	2C1.6DL	330	6
2	250	2C2DL	330	6
3	250	2C3DL	330	6
4	250	2C4DL	330	6
5	250	2C5DL	330	6
6	250	2C6DL	330	6
8	250	2C8DL	330	6
10	250	2C10DL	330	6
12	250	2C12DL	330	6
13	250	2C13DL	330	6
15	250	2C15DL	330	6
16	250	2C16DL	330	6
20	250	2C20DL	330	6
25	250	2C25DL	330	6
30	250	2C30DL	330	6
32	250	2C32DL	330	6
40	250	2C40DL	330	6
50	250	2C50DL	330	6
60	250	2C60DL	330	6
63	250	2C63DL	330	6



Correct polarity must be ensured when connecting the DC switching devices!

ACCESSORIES FOR SWITCHING DEVICES LISTED CIRCUIT BREAKERS

according to UL 489 and CSA-22.2 No. 5-09 for Product Ranges UL and DL

Mounting Instructions of Accessories

Applies to N...UL and FA...UL:

The accessory devices N...UL and FA...UL can be installed on the right or left.

Mounting

1. Bring the blue knobs of all devices into the "OFF" position
2. Remove grey cover from the switching device and attachment
3. Insert drive plate between the switching device and N...UL or FA...UL
4. Insert connecting pin into the knob (insertion depth approx. 7 mm)
5. Attach switching device to N... N...UL or FA...UL
6. Tighten the connecting screws (observe the the correct screw length)

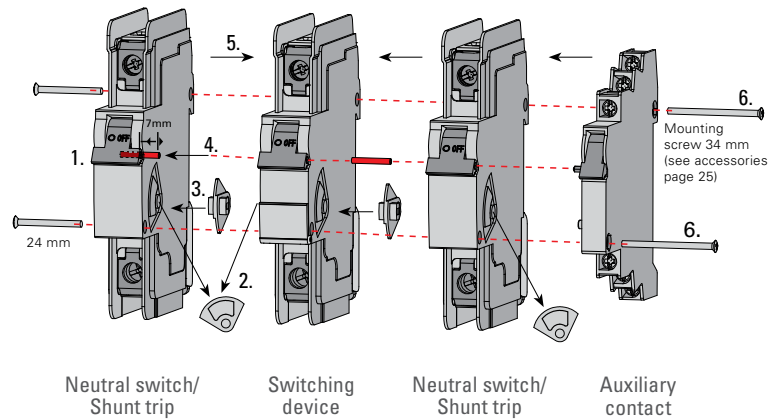

Applies to H...UL

The auxiliary contact H...UL can only be installed on the right.

Installation

1. Flick the blue switches of all devices to the "OFF" position
2. Remove the grey cover from the switching device and attachment
3. Attach switching device to H...UL
4. Insert the connecting screws and fasten them by a 90° clockwise turn
5. After installation, close and open the switch to check correct operation

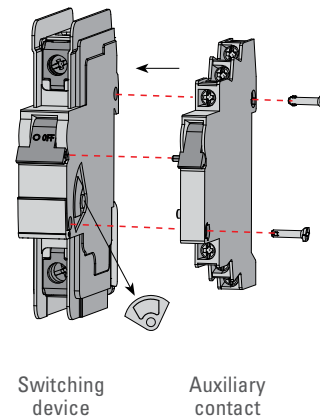

Applies to all switching devices ...UL, ...DL, N32UL, N63UL and FA...UL

The load and mains can be connected into either the top or bottom terminals (line/load reversible).

Design of the terminals

- Optical detection of screw position
- Increased breaking resistance if the screwdriver becomes jammed
- Universal connecting terminals, suitable for connecting all known cable lugs such as ring or forked cable lugs and pin terminals
- Ring cable lugs can be connected by opening the flap and removing the connecting screw
- Can also be used for applications that require ring cable lugs (e.g. nuclear power stations)
- DIN EN 50274, VDE 0660-514 compliant protection against contact with live parts is fully guaranteed



1. Box terminal for
· solid conductors
· flexible conductors with
or without cable lug

2. Screw terminal
for forked cable lug

3. Screw terminal
for ring cable lug
(ring tongue)

ACCESSORIES FOR SWITCHING DEVICES LISTED CIRCUIT BREAKERS

according to UL 489 and CSA-22.2 No. 5-09 for Product Ranges UL and DL



Auxiliary contact, for mounting on the right

MODULE	TYPE OF CONTACT	CONTACTS	ITEM NO.	WEIGHT G/EACH	PACKING UNIT
1/2	1 auxiliary contact	1NO	H10UL	35	6
1/2	2 auxiliary contacts	1NO + 1NC	H11UL	40	6
1/2	3 auxiliary contacts	1NO + 2NC	H12UL	45	6
1/2	3 auxiliary contacts	2NO + 1NC	H21UL	45	6

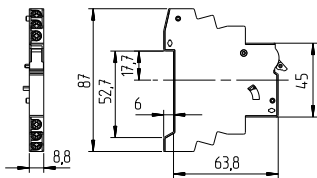

Standards	UL 489 and CSA-22.2 Nr. 5-09	
Rated operating currents	10 A / 240 V AC 3 A / 110 V DC 1 A / 220 V DC	
Minimum contact load	1 mA at 24 V DC	
Conductor cross sections		
Type of conductor *)	min.	max.
Single wire	1.0 mm ² (AWG18)	2.5 mm ² (AWG14)
Stranded wire	1.0 mm ² (AWG18)	1.5 mm ² (AWG16)
Stranded wire with ferrule	1.0 mm ² (AWG18)	1.5 mm ² (AWG16)
Torque	max. 0.8 Nm (7 lb.in)	

*) Stripped length 8 - 9 mm () values in brackets = measurement units for North America



Shunt trip, for mounting on the right or left

MODULE	RATED OPERATING VOLTAGE	MAX. OPERATING CURRENT AT U _n (T < 10 MS)	ITEM NO.	WEIGHT G/EACH	PACKING UNIT
1	12 V UC	1.3 A	FA12UL	110	5
1	24 V UC	0.6 A	FA24UL	110	5
1	48 - 72 V UC	0.2 A	FA48UL	110	5
1	110 - 240 V UC, 277 V AC	0.25 A at 110 V 0.5 A at 240 V 0.58 A at 277 V	FA110UL	110	5

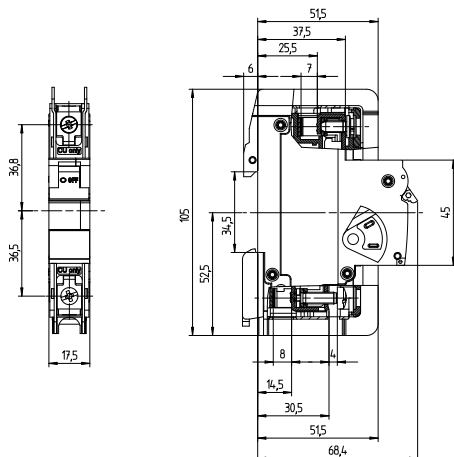

Activation lock

ITEM NO.	WEIGHT G/EACH	PACKING UNIT
EASS	2	10

DIMENSION DRAWINGS FA...UL, N32UL AND N63UL

ACCESSORIES FOR SWITCHING DEVICES LISTED CIRCUIT BREAKERS

according to UL 489 and CSA-22.2 No. 5-09 for Product Ranges UL and DL



FILE E 346095

Busbars pin type

CROSS SECTION [MM ²]	BUSBAR CURRENT	NUMBER OF POLES	ITEM NO.	WEIGHT G/EACH	PACKING UNIT
----------------------------------	----------------	-----------------	----------	---------------	--------------

1-phase, L1

16	115	6	S106U	58	1
16	115	9	S109U	78	1
16	115	12	S112U	115	1

1-phase, L1 + Auxiliary contact

16	115	6	S106UH	64	1
16	115	8	S108UH	86	1

2-phase, L1-L2

16	115	6	S206U	67	1
16	115	10	S210U	112	1
16	115	12	S212U	132	1

2-phase, L1-L2 + Auxiliary contact

16	115	8	S208UH	92	1
16	115	10	S210UH	120	1

3-phase, L1-L2-L3

16	115	6	S306U	72	1
16	115	9	S309U	108	1
16	115	12	S312U	140	1

3-phase, L1-L2-L3 +Auxiliary contact

16	115	6	S306UH	98	1
16	115	9	S309UH	130	1



Power feed terminals

Power feed terminals

2,5-50	115		AK35U	33	3
--------	-----	--	--------------	----	---

Protection cover for busbars

			S3BRU	5	5
--	--	--	--------------	---	---



Protection cover for busbars

Mounting screw 34 mm

to connect the auxiliary contact and shunt trip or neutral switch to the switching devices

ITEM NO.	PACKING UNIT
----------	--------------

E983419	10 pieces
----------------	-----------



Protection caps

to cover the connecting screws on the switching devices, neutral switches and shunt trips for increased touch protection

ITEM NO.	PACKING UNIT
----------	--------------

BS.UL	100 pieces
--------------	------------

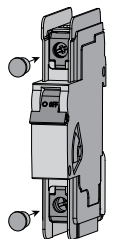

BUSBARS

and Power Feed Terminal UL 489

Number of phases	1, 2 and 3	
Number of pins	6 to 12	
Cross section	16 mm ²	
Short circuit withstand rating	10 kA	
Rated voltage	480Y / 277V	
Rated current	115 A	
Ambient temperature	-25°C to +40°C	
	Conductor cross sections AK35U	
Type of conductor	max.	min.
Single wire	50 mm ² (AWG 1)	2,5 mm ² (AWG 14)
Multiple wire	50 mm ² (AWG 1)	2,5 mm ² (AWG 14)
Stranded wire	35 mm ² (AWG 1)	2,5 mm ² (AWG 14)
Stranded wire with ferrule	35 mm ² (AWG 1)	2,5 mm ² (AWG 14)
Stripped length	18-20 mm (0,7-0,8 in.)	
Torque	max. 6 Nm (53 lb.in)	

() values in brackets = measurement units for North America
 Copper conductors with sheath insulation for 75°C

Power Feed Terminals connected
 ≤ 240V AC

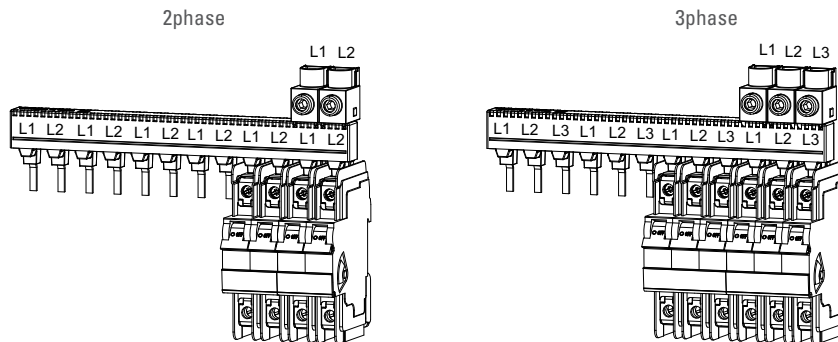

Power Feed Terminals connected
 480Y / 277V AC

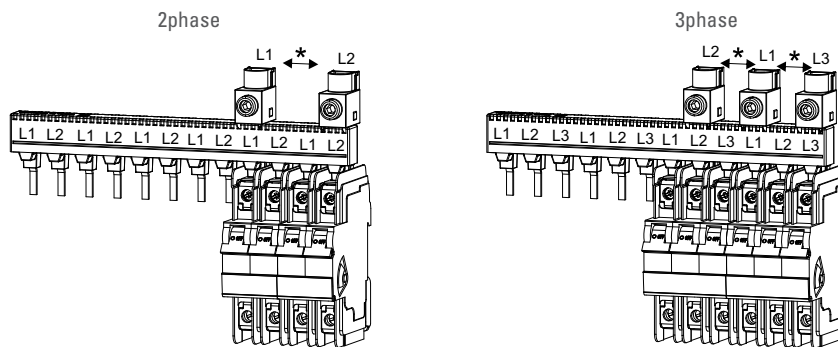

* Art applications with a voltage rated 480Y / 277V have to maintain a minimum distance of one pole between power feed terminals of different polarity!

SWITCHING DEVICES LISTED CIRCUIT BREAKERS AC

according to UL 489 and CSA-22.2 No. 5-09 · Technical Data Product Range UL

Characteristic *		C	D
Application		Lighting Wiring protection Control circuits Business equipment appliances Motors with low inrush current	Transformers Power supplies Heaters Motors with high inrush current Reactive loads
Number of poles		1 - 3; 1 + N; 3 + N	
Standards		UL 489 and CSA-22.2 Nr. 5-09	
Interrupting capacity		10 kA	
Back-up fuse ≤ 10 kA interrupting capacity		none	
Rated voltage AC 50/60 Hz 0.3 - 32 A		277 / 480 V	
Rated voltage AC 50/60 Hz 40 - 63 A		240 V	
Rated current range		0.3 - 63 A	0.3 - 63 A
Test currents	Thermal not tripping $I_1 (A) > 1 \text{ h}$	$1.05 \times I_n$	$1.05 \times I_n$
	Thermal tripping $I_2 (A) < 1 \text{ h}$	$1.35 \times I_n$	$1.35 \times I_n$
	Electromagnetic not tripping $I_4 (A) > 0.1 \text{ s}$	$5 \times I_n$	$10 \times I_n$
	Electromagnetic tripping $I_5 (A) < 0.1 \text{ s}$	$10 \times I_n$	$16 \times I_n$
Reference calibration temperature of the thermal tripping threshold		40 °C Influence of the ambient temperature on the thermal release threshold: Decrease of the current values with higher ambient temperature and increase with lower temperatures of approximately 5 % per 10 °C difference in temperature	
Frequency range of the electromagnetic trip		16 ² / ₃ to 60 Hz With higher frequencies, the electromagnetic tripping threshold increases by approximately a factor of 1.1 at 100 Hz; 1.2 at 200 Hz; 1.3 at 300 Hz; 1.4 at 400 Hz; 1.5 for DC	
Ambient temperature		-25 °C to +55 °C	
Storage temperature		-40 °C to +70 °C	
Device depth according to DIN 43880		68 mm	
Mechanical life		10,000 switching cycles (ON / OFF)	
Protection cover		Finger safe and safe to back of hand according to DIN EN 50274, VDE 0660-514	
Degree of protection acc. EN / IEC 60529		IP20	
Installation position		any	
Mounting		DIN-rail according to DIN EN 60715 35 mm	
Lockability		The handle can be secured against manual switching in the on and off position by a lead seal	
Climatic resistance		Humid heat constant according to DIN EN 60068-2-78 Humid heat cycle according to DIN EN 60068-2-30	
Vibration resistance		> 15 g according to DIN EN 60068-2-59 during a load with I_1	
Resistance to mechanical shocks		25 g 11 ms	

* Other switching devices in B and Z characteristics available on request

Interrupting capacity acc. to IEC 60947-2, DIN EN 60947-2

CHARACTERISTIC	C, D		
1pole	0,3 - 63 A	240 V	15 kA
2pole / 3pole	0,3 - 32 A	415 V	15 kA
2pole / 3pole	40 - 63 A	415 V	10 kA



FILE E 329510

SWITCHING DEVICES LISTED CIRCUIT BREAKERS DC

according to UL 489 and CSA-22.2 No. 5-09 · Technical Data Product Range DL

Characteristic		C
Application		Lighting Wiring protection Control circuits Business equipment appliances Motors with low inrush current
Number of poles		1 and 2
Standards		UL 489 and CSA-22.2 Nr. 5-09
Interrupting capacity		10 kA
Back-up fuse ≤ 10 kA interrupting capacity		none
Rated voltage DC 1-pole		125 V
Rated voltage DC 2-pole		250 V
Rated current range		0.3 - 63 A
Test currents	Thermal not tripping $I_1 (A) > 1 \text{ h}$	$1.05 \times I_n$
	Thermal tripping $I_2 (A) < 1 \text{ h}$	$1.35 \times I_n$
	Electromagnetic not tripping $I_4 (A) > 0.1 \text{ s}$	$7 \times I_n$
	Electromagnetic tripping $I_5 (A) < 0.1 \text{ s}$	$14 \times I_n$
Reference calibration temperature of the thermal tripping threshold		40 °C Influence of the ambient temperature on the thermal release threshold: Decrease of the current values with higher ambient temperature and increase with lower temperatures of approximately 5 % per 10 °C difference in temperature
Ambient temperature		-25 °C to +55 °C
Storage temperature		-40 °C to +70 °C
Device depth according to DIN 43880		68 mm
Mechanical life		10,000 switching cycles (ON / OFF)
Protection cover		Finger safe and safe to back of hand according to DIN EN 50274, VDE 0660-514
Degree of protection acc. EN / IEC 60529		IP20
Installation position		any
Mounting		DIN-rail according to DIN EN 60715 35 mm
Lockability		The handle can be secured against manual switching in the on and off position by a lead seal
Climatic resistance		Humid heat constant according to DIN EN 60068-2-78 Humid heat cycle according to DIN EN 60068-2-30
Vibration resistance		> 15 g according to DIN EN 60068-2-59 during a load with I_1
Resistance to mechanical shocks		25 g 11 ms



FILE E 329510

SWITCHING DEVICES LISTED CIRCUIT BREAKERS

according to UL 489 and CSA-22.2 No. 5-09 · Technical Data Product Ranges UL and DL

DIMENSION DRAWINGS PRODUCT RANGES UL AND DL

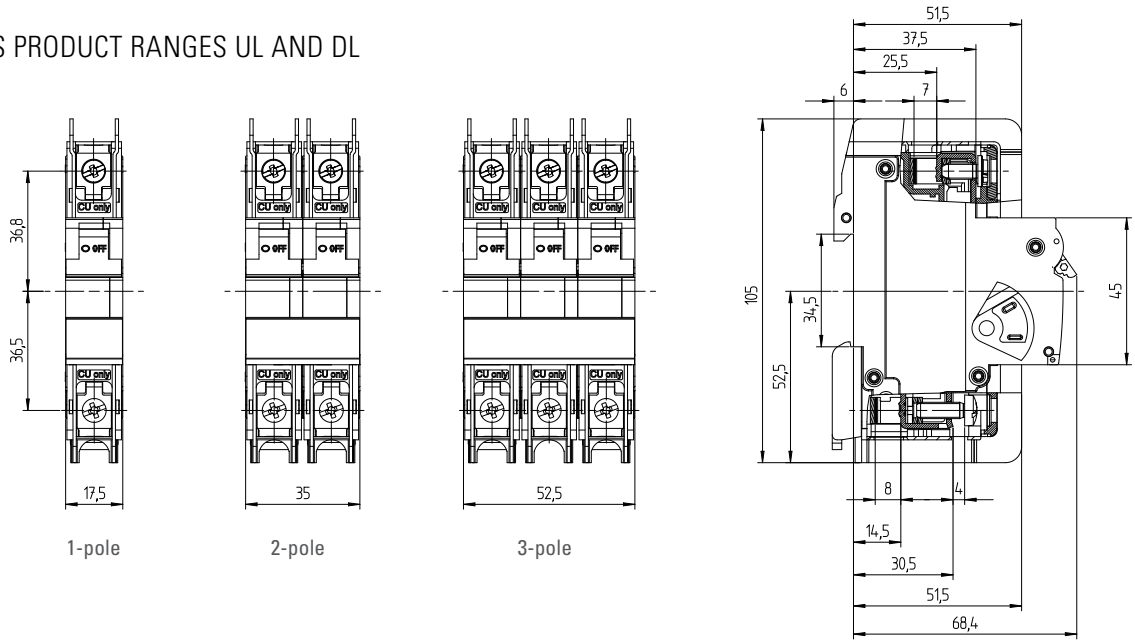

TECHNICAL DATA

Type of conductor *)	Conductor cross sections			
	Box terminal bottom		Box terminal top	
	max.	min.	max.	min.
Single wire	35 mm ² (AWG2)	1.0 mm ² (AWG18)	25 mm ² (AWG3)	1.0 mm ² (AWG18)
Multiple wire	35 mm ² (AWG2)	16 mm ² (AWG6)	25 mm ² (AWG3)	16 mm ² (AWG6)
Stranded wire	25 mm ² (AWG3)	1.0 mm ² (AWG18)	16 mm ² (AWG6)	1.0 mm ² (AWG18)
Stranded wire with ferrule	16 mm ² (AWG6)	1.0 mm ² (AWG18)	16 mm ² (AWG6)	1.0 mm ² (AWG18)
Busbar cable lug	up to 3 mm thickness		up to 1.5 mm thickness	
Combined, conductor and busbar or cable lug	up to 35 mm ² and up to 2 mm thickness		not possible	
Torque	max. 2.5 Nm (22.2 lb.in)			

*) Stripped lengths: 12 - 14 mm at the bottom, 10 - 12 mm at the top

() values in brackets = measurement units for North America Copper conductor with sheath insulation for 60/75 °C

Rated current [A]	Internal Resistance for Product Ranges UL and DL	
	Trip characteristic	
	C [Ohm]	D [Ohm]
0.3	16.8620	16.8620
0.5	6.8540	6.0009
1.0	1.7000	1.7560
1.6	0.5870	0.5870
2.0	0.4190	0.4190
3.0	0.2020	0.2020
4.0	0.1090	0.1090
5.0	0.0654	0.0654
6.0	0.0528	0.0491
8.0	0.0278	0.0240
10	0.0216	0.0187
12	0.0084	0.0085
13	0.0084	0.0085
15/16	0.0085	0.0076
20	0.0067	0.0064
25	0.0050	0.0041
30/32	0.0032	0.0027
40	0.0025	0.0022
50	0.0019	0.0018
60/63	0.0018	0.0017

SWITCHING DEVICES LISTED CIRCUIT BREAKERS

according to UL 489 and CSA-22.2 No. 5-09 · Characteristic Product Ranges UL and DL



FILE E 329510

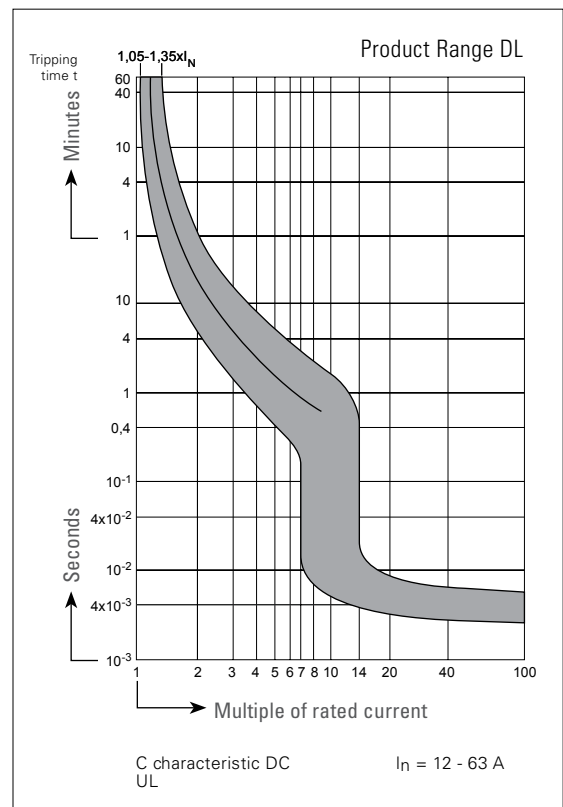
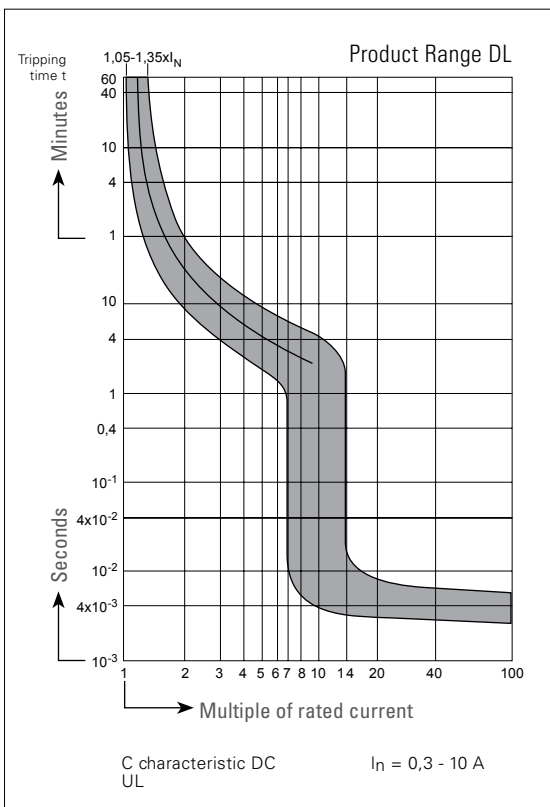
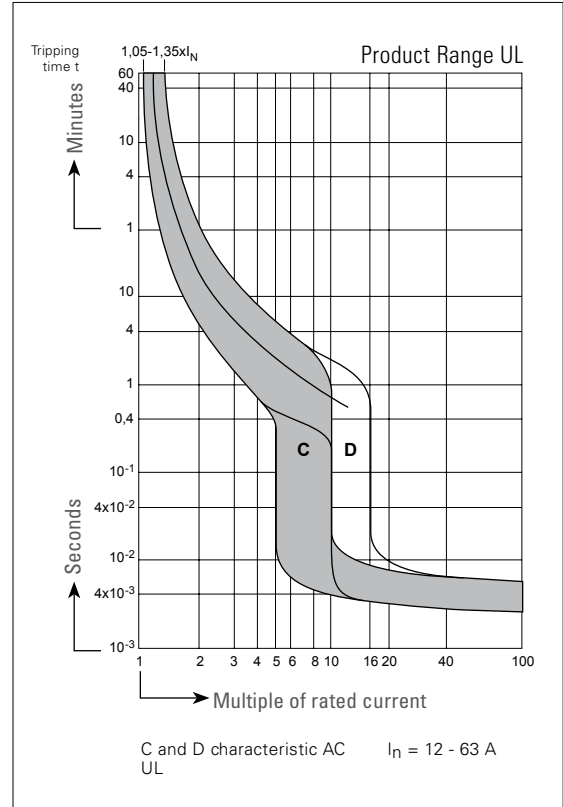
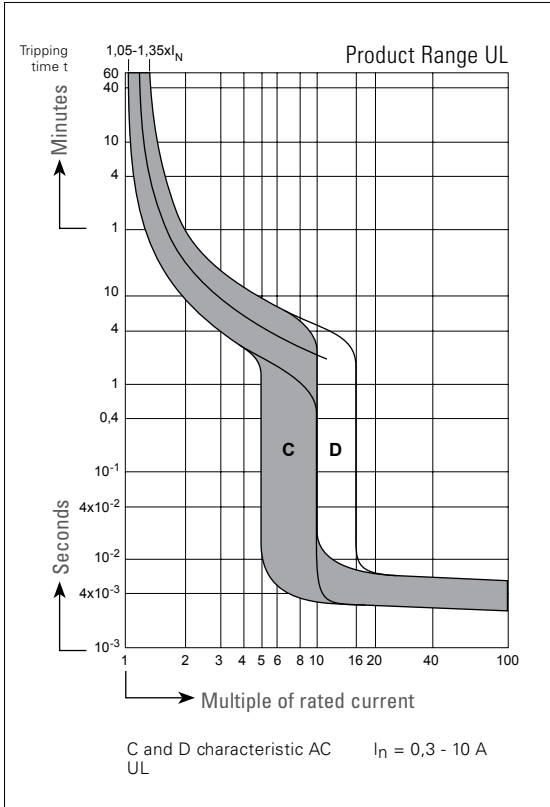





UL 508

UL 508 AND CSA-22.2 NO. 14 COMPLIANT SWITCHING DEVICES

UL 508 and CSA-22.2 compliant manual motor controllers are considered as control equipment without short circuit protection function.

Our range of UL 508 motor controllers in the Miniature Circuit Breaker (MCB) design offers a convenient installation solution with both single and double pole versions available especially for single phase motors. They are "Suitable as Motor Disconnect" and can be used for "Motor Starting Across the Line". With its wide range of trip characteristics it also offers the best possible protection in some specific applications. The "Z" type offers the best protection for electronic devices, semiconductors and components with low surge current and resistance capabilities.

Our range offers 1, 2 and 3 pole devices, available as UL types G and E, as well as IEC types B, C, D, and Z. In combination with the typical nominal ratings of both standards we can offer the best possible protection for each application.

Our system offers the most convenient solutions for applications up to 25 A, for which our devices are both IEC and UL approved. In combination with our UL approved busbar technology, installation can be easily adapted for compliance with both standards. It offers OEMs the opportunity to broadly standardize their electrical installation independently of the location where the equipment will be used later.

SWITCHING DEVICES MANUAL MOTOR CONTROLLER

according to UL 508 and CSA-22.2 No.14

EUROPEAN-TYPE OF BUSBAR WIRING TESTED AND APPROVED FOR UL
(AT LEAST ONE MOTOR CONTAINED IN THE CIRCUIT)



Power feed terminals
1.5 to 35 mm²

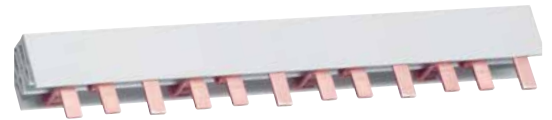

Busbars 18 and 25 mm²



Protection cover for busbars

UL-APPROVED ACCESSORIES

File E137938

Switching devices
1-pole to 3-pole
Neutral switch
can be mounted

Characteristic:
B, C, D, E, G and Z

Rated currents:
0.3 to 63 A
(63 A without UL
approval)



Activation lock



Auxiliary contact

Shunt trip

SWITCHING DEVICES MANUAL MOTOR CONTROLLER

according to UL 508 and CSA-22.2 No.14 UM Product Range, B, C, D,G, E and Z Characteristic B, C and D also acc. to IEC 60898-1, DIN EN 60898-1, VDE 0641-11 (B, C, D Characteristic 0.3 - 25 A)



RATED CURRENT I_N A	CHARACTERISTIC						WEIGHT G/EACH	PACKING UNIT
	B ITEM NO.	C ITEM NO.	D ITEM NO.	G ITEM NO.	E ITEM NO.	Z ITEM NO.		
1-pole								
0.3		1C03UM	1D03UM	1G03UM	1E03UM	1Z03UM	150	12
0.5		1C05UM	1D05UM	1G05UM	1E05UM	1Z05UM	150	12
0.75		1C075UM	1D075UM		1E075UM	1Z075UM	150	12
0.8				1G08UM				
1	1B1UM	1C1UM	1D1UM	1G1UM	1E1UM	1Z1UM	150	12
1.6	1B1.6UM	1C1.6UM	1D1.6UM	1G1.6UM	1E1.6UM	1Z1.6UM	150	12
2	1B2UM	1C2UM	1D2UM	1G2UM	1E2UM	1Z2UM	150	12
2.5	1B2.5UM	1C2.5UM	1D2.5UM	1G2.5UM	1E2.5UM	1Z2.5UM	150	12
3	1B3UM	1C3UM	1D3UM	1G3UM	1E3UM	1Z3UM	150	12
3.5	1B3.5UM	1C3.5UM	1D3.5UM	1G3.5UM	1E3.5UM	1Z3.5UM	150	12
4	1B4UM	1C4UM	1D4UM	1G4UM	1E4UM	1Z4UM	150	12
5	1B5UM	1C5UM	1D5UM	1G5UM	1E5UM	1Z5UM	150	12
6	1B6UM	1C6UM	1D6UM	1G6UM	1E6UM	1Z6UM	150	12
8		1C8UM	1D8UM	1G8UM	1E8UM	1Z8UM	150	12
10	1B10UM	1C10UM	1D10UM	1G10UM	1E10UM	1Z10UM	150	12
12				1G12UM		1Z12UM		
13	1B13UM	1C13UM	1D13UM	1G13UM	1E13UM	1Z13UM	150	12
15	1B15UM	1C15UM	1D15UM	1G15UM	1E15UM	1Z15UM		
16	1B16UM	1C16UM	1D16UM	1G16UM	1E16UM	1Z16UM	150	12
20	1B20UM	1C20UM	1D20UM	1G20UM	1E20UM	1Z20UM	150	12
25	1B25UM	1C25UM	1D25UM	1G25UM	1E25UM	1Z25UM	150	12
30	1B30UM	1C30UM	1D30UM	1G30UM	1E30UM	1Z30UM		
32	1B32UM	1C32UM	1D32UM	1G32UM	1E32UM	1Z32UM	150	12
40	1B40UM	1C40UM	1D40UM	1G40UM	1E40UM	1Z40UM	150	12
50	1B50UM	1C50UM	1D50UM	1G50UM	1E50UM	1Z50UM	150	12
60	1B60UM	1C60UM	1D60UM	1G60UM	1E60UM		150	12
63 *	1B63UM	1C63UM	1D63UM	1G63UM	1E63UM		150	12

* 63 A without UL approval

SWITCHING DEVICES MANUAL MOTOR CONTROLLER

according to UL 508 and CSA-22.2 No.14 UM Product Range, B, C, D,G, E and Z Characteristic B, C and D also acc. to IEC 60898-1, DIN EN 60898-1, VDE 0641-11 (B, C, D Characteristic 0.3 - 25 A)



RATED CURRENT I_n A	CHARACTERISTIC						WEIGHT G/EACH	PACKING UNIT
	B ITEM NO.	C ITEM NO.	D ITEM NO.	G ITEM NO.	E ITEM NO.	Z ITEM NO.		

2-pole								
0.3		2C03UM	2D03UM	2G03UM	2E03UM	2Z03UM	300	6
0.5		2C05UM	2D05UM	2G05UM	2E05UM	2Z05UM	300	6
0.75		2C075UM	2D075UM		2E075UM	2Z075UM	300	6
0.8				2G08UM				
1	2B1UM	2C1UM	2D1UM	2G1UM	2E1UM	2Z1UM	300	6
1.6		2C1.6UM	2D1.6UM	2G1.6UM	2E1.6UM	2Z1.6UM	300	6
2		2C2UM	2D2UM	2G2UM	2E2UM	2Z2UM	300	6
2.5		2C2.5UM	2D2.5UM	2G2.5UM	2E2.5UM	2Z2.5UM	300	6
3	2B3UM	2C3UM	2D3UM	2G3UM	2E3UM	2Z3UM	300	6
3.5		2C3.5UM	2D3.5UM	2G3.5UM	2E3.5UM	2Z3.5UM	300	6
4	2B4UM	2C4UM	2D4UM	2G4UM	2E4UM	2Z4UM	300	6
5	2B5UM	2C5UM	2D5UM	2G5UM	2E5UM	2Z5UM	300	6
6	2B6UM	2C6UM	2D6UM	2G6UM	2E6UM	2Z6UM	300	6
8		2C8UM	2D8UM	2G8UM	2E8UM	2Z8UM	300	6
10	2B10UM	2C10UM	2D10UM	2G10UM	2E10UM	2Z10UM	300	6
12				2G12UM		2Z12UM		
13	2B13UM	2C13UM	2D13UM	2G13UM	2E13UM	2Z13UM	300	6
15	2B15UM	2C15UM	2D15UM	2G15UM	2E15UM	2Z15UM		
16	2B16UM	2C16UM	2D16UM	2G16UM	2E16UM	2Z16UM	300	6
20	2B20UM	2C20UM	2D20UM	2G20UM	2E20UM	2Z20UM	300	6
25	2B25UM	2C25UM	2D25UM	2G25UM	2E25UM	2Z25UM	300	6
30	2B30UM	2C30UM	2D30UM	2G30UM	2E30UM	2Z30UM		
32	2B32UM	2C32UM	2D32UM	2G32UM	2E32UM	2Z32UM	300	6
40	2B40UM	2C40UM	2D40UM	2G40UM	2E40UM	2Z40UM	300	6
50	2B50UM	2C50UM	2D50UM	2G50UM	2E50UM	2Z50UM	300	6
60	2B60UM	2C60UM	2D60UM	2G60UM	2E60UM		300	6
63 *	2B63UM	2C63UM	2D63UM	2G63UM	2E63UM		300	6

* 63 A without UL approval

SWITCHING DEVICES MANUAL MOTOR CONTROLLER

according to UL 508 and CSA-22.2 No.14 UM Product Range, B, C, D,G, E and Z Characteristic B, C and D also acc. to IEC 60898-1, DIN EN 60898-1, VDE 0641-11 (B, C, D Characteristic 0.3 - 25 A)

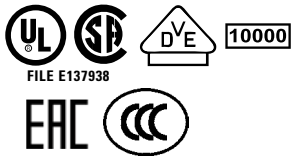

RATED CURRENT I_N A	CHARACTERISTIC						WEIGHT G/EACH	PACKING UNIT
	B ITEM NO.	C ITEM NO.	D ITEM NO.	G ITEM NO.	E ITEM NO.	Z ITEM NO.		

3-pole								
0.3		3C03UM	3D03UM	3G03UM	3E03UM	3Z03UM	450	4
0.5		3C05UM	3D05UM	3G05UM	3E05UM	3Z05UM	450	4
0.75		3C075UM	3D075UM		3E075UM	3Z075UM	450	4
0.8				3G08UM				
1	3B1UM	3C1UM	3D1UM	3G1UM	3E1UM	3Z1UM	450	4
1.6	3B1.6UM	3C1.6UM	3D1.6UM	3G1.6UM	3E1.6UM	3Z1.6UM	450	4
2	3B2UM	3C2UM	3D2UM	3G2UM	3E2UM	3Z2UM	450	4
2.5	3B2.5UM	3C2.5UM	3D2.5UM	3G2.5UM	3E2.5UM	3Z2.5UM	450	4
3	3B3UM	3C3UM	3D3UM	3G3UM	3E3UM	3Z3UM	450	4
3.5	3B3.5UM	3C3.5UM	3D3.5UM	3G3.5UM	3E3.5UM	3Z3.5UM	450	4
4	3B4UM	3C4UM	3D4UM	3G4UM	3E4UM	3Z4UM	450	4
5	3B5UM	3C5UM	3D5UM	3G5UM	3E5UM	3Z5UM	450	4
6	3B6UM	3C6UM	3D6UM	3G6UM	3E6UM	3Z6UM	450	4
8		3C8UM	3D8UM	3G8UM	3E8UM	3Z8UM	450	4
10	3B10UM	3C10UM	3D10UM	3G10UM	3E10UM	3Z10UM	450	4
12				3G12UM		3Z12UM		
13	3B13UM	3C13UM	3D13UM	3G13UM	3E13UM	3Z13UM	450	4
15	3B15UM	3C15UM	3D15UM	3G15UM	3E15UM	3Z15UM		
16	3B16UM	3C16UM	3D16UM	3G16UM	3E16UM	3Z16UM	450	4
20	3B20UM	3C20UM	3D20UM	3G20UM	3E20UM	3Z20UM	450	4
25	3B25UM	3C25UM	3D25UM	3G25UM	3E25UM	3Z25UM	450	4
30	3B30UM	3C30UM	3D30UM	3G30UM	3E30UM	3Z30UM		
32	3B32UM	3C32UM	3D32UM	3G32UM	3E32UM	3Z32UM	450	4
40	3B40UM	3C40UM	3D40UM	3G40UM	3E40UM	3Z40UM	450	4
50	3B50UM	3C50UM	3D50UM	3G50UM	3E50UM	3Z50UM	450	4
60	3B60UM	3C60UM	3D60UM	3G60UM	3E60UM		450	4
63 *	3B63UM	3C63UM	3D63UM	3G63UM	3E63UM		450	4

* 63 A without UL approval



RATED CURRENT I_N A	RATED VOLTAGE VOLT AC	TEST CURRENTS * ELECTROMAGNETIC		ITEM NO.	WEIGHT G/EACH	PACKING UNIT
		NOT TRIPPING I_A	TRIPPING I_s A			

Neutral switch – for mounting instructions please consult page 39						
0.3 - 63	277/480	400	700	N63UM	150	5

* additional electromagnetic protection



ACCESSORIES FOR SWITCHING DEVICES

Manual Motor Controller and Supplementary Protectors
according to UL 508 and CSA-22.2 No.14 for Product Ranges UM and UR

Accessory Installation Instructions

Applies to N...UM and FA...UM:

The accessory devices N...UM and FA...UM can be installed on the right or left.

Installation:

1. Flick the blue switches of all devices to the "OFF" position
2. Remove the grey cover from switching device and attachment
3. Insert the drive plate between switching device and N...UM or FA...UM
4. Insert the connecting pin into the switch (insertion depth approx. 7mm)
5. Attach switching device to N...UM or FA...UM
6. Tighten the connecting screws (observe the the correct srew length)

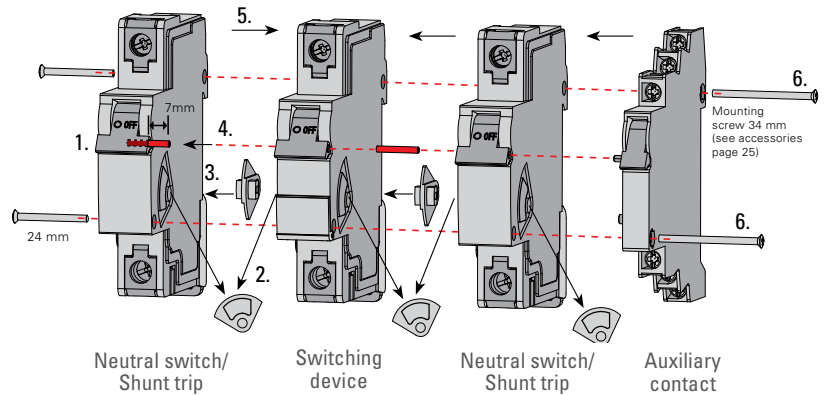

Applies to H...UM:

The auxiliary contact H...UM can only be installed on the right.

Installation:

1. Flick the blue switches of both devices to the "OFF" position
2. Remove the grey cover from the switching device
3. Attach switching device to H...UM
4. Insert the connecting screws and fasten them by a 90° clockwise turn
5. After installation, close and open the switch to check correct operation

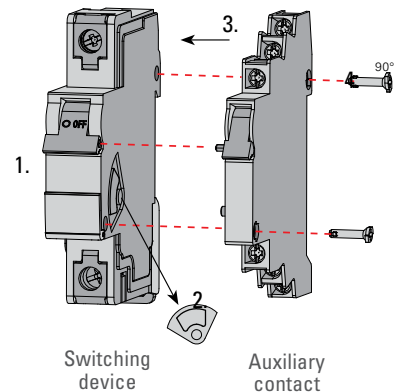

Applies to all switching devices ...UM, N63UM and FA...UM:

The load and mains can be connected into either the top or bottom terminals (line/load reversible).

Design of the terminals

- Optical detection of screw position
- Increased breaking resistance if the screwdriver becomes jammed
- Universal connecting terminals, suitable for connecting all known cable lugs, such as ring or forked cable lugs and pin terminals
- Ring cable lugs can be connected by opening the flap and removing the connecting screw
- Can also be used for applications that require ring cable lugs (e.g. nuclear power stations)
- DIN EN 50274, VDE 0660-514 compliant protection against contact with live parts is fully guaranteed

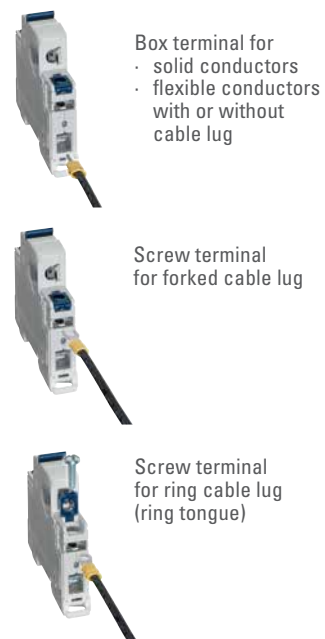

ACCESSORIES FOR SWITCHING DEVICES

Manual Motor Controller and Supplementary Protectors

according to UL 508 and CSA-22.2 No.14 for Product Ranges UM and UR



FILE E137938



Auxiliary contact

MODULE	TYPE OF CONTACT	CONTACTS	ITEM NO.	WEIGHT G/EACH	PACKING UNIT
1/2	1 auxiliary contact	1NO	H10UM	35	10
1/2	2 auxiliary contacts	1NO + 1NC	H11UM	40	10
1/2	3 auxiliary contacts	1NO + 2NC	H12UM	45	10
1/2	3 auxiliary contacts	2NO + 1NC	H21UM	45	10

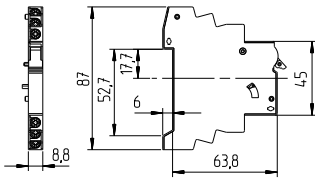

Standards	Acc. to IEC 60947-5-1, DIN EN 60947-5-1, VDE 0660-200, UL 508	
Rated operating currents	10 A /240 V AC 3 A / 110 V DC 1 A / 220 V DC	
Minimum contact load	1 mA at 24 V DC	
Conductor cross sections		
Type of conductor *)	min.	max.
Single wire	1.0 mm ² (AWG18)	2.5 mm ² (AWG14)
Stranded wire	1.0 mm ² (AWG18)	1.5 mm ² (AWG16)
Stranded wire with ferrule	1.0 mm ² (AWG18)	1.5 mm ² (AWG16)
Torque	max. 0.8 Nm (7 lb.in)	

*) Stripped length 8 - 9 mm

Shunt trip

MODULE	RATED OPERATING VOLTAGE	MAX. OPERATING CURRENT AT UN (T < 10 MS)	ITEM NO.	WEIGHT G/EACH	PACKING UNIT
1	12 V UC	1.3 A	FA12UM	105	5
1	24 V UC	0.6 A	FA24UM	105	5
1	48 - 74 V UC	0.2 A	FA48UM	105	5
1	110 - 240 V UC, 415 V AC	0.25 A at 110 V 0.5 A at 240 V 0.58 A at 277 V	FA110UM	105	5



FILE E137938

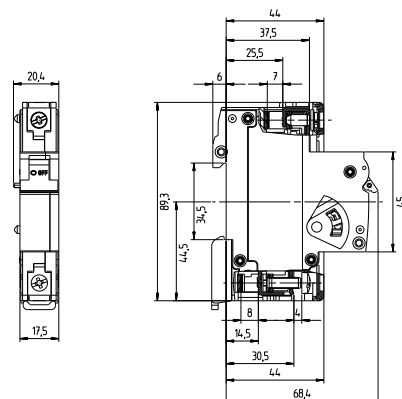

DIMENSION DRAWING FA..UM, N63UM



Activation lock

ITEM NO.	WEIGHT G/EACH	PACKING UNIT
EASS	2	10

BUSBARS FOR SWITCHING DEVICES MANUAL MOTOR CONTROLLER

according to UL 508 and CSA-22.2 No.14 for Product Ranges UM and MA...UM



CROSS SECTION (MM ²)	BUSBAR CURRENT START OF BUSBAR/ MIDDLE INFEEED	MODULES/ PHRASES	ITEM NO.	WEIGHT G / EACH	PACKING UNIT	SUITABLE END CAP ITEM NO.
----------------------------------	--	------------------	----------	-----------------	--------------	---------------------------

Busbars pin type acc. to UL and CSA						
1-phase						
18	80/130	57	SB.U1	300	1	
1-phase 1-pole switching device + auxiliary contact						
18	80/130	37/1	SB.U1H	280	1	
3-phase						
18	80/130	19/3	SB.U3	800	1	SB.U8
3-phase 3-pole switching device + auxiliary contact						
25	100/180	16/3	SB.U3H	1020	1	SB.U8



Power feed terminals						
6 - 35	115		AK.U1	35	1	



Protection cover for UL and CSA busbars						
			SB.U9	0.6/3	1 strip = 5 pieces	

BUSBARS

for Manual Motor Controllers, Product Ranges UM and MA...UM

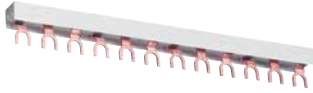

CROSS SECTION (MM ²)	BUSBAR CURRENT START OF BUSBAR/ MIDDLE INFEEED	MODULES/ PHRASES	ITEM NO.	WEIGHT G/EACH	PACKING UNIT	SUITABLE END CAP ITEM NO.
----------------------------------	--	------------------	----------	---------------	--------------	---------------------------

Busbars fork type without UL and CSA approval						
1-phase						
12	65/110	56/1	SB16010	250	50	
1-phase 1-pole switching device + auxiliary contact						
24	90/150	37/1	SDO.124	200	50	
2-phase and 1-phase + N						
10	63/100	28/2	SB26010	390	20	SB.A5
2-phase 2-pole switching device + auxiliary contact						
16	80/130	22/2	SB26216	310	20	SB.A2
3-phase						
10	63/100	4/3	SB31210	84	25	SB.A1
10	63/100	19/3	SB36010	420	20	SB.A1
16	80/130	19/3	SB36016	675	20	SB.A2
3-phase 3-pole switching device + auxiliary contact						
16	80/130	16/3	SB36316	630	20	SB.A2
3-phase 1-pole switching device + auxiliary contact						
16	80/130	36/1	SDO.316	500	20	SB.A2
4-phase and 3-phase + N						
16	80/130	14/4	SB46016	835	15	SB.A3

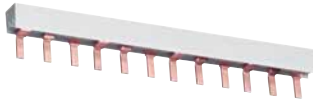

Busbars pin type without UL and CSA approval						
3-phase						
16	80/130	19/3	SB718U	500	20	SB.A2

SWITCHING DEVICES MANUAL MOTOR CONTROLLER

according to UL 508 and CSA-22.2 No.14 · Technical Data Product Range UM

Characteristic	B	C	D	E	G	Z
Application	Lighting Circuits control Wiring protection Business equipment Appliances	Lighting Circuits control Wiring protection Business equipment Appliances Motors (low inrush current)	Transformers Power supplies Reactive load Motors (high inrush current)	Transformers Power supplies Motors (high efficiency)	Lighting Circuits control Wiring protection Transformers Solenoid Motors (general)	Wiring protection Semiconductor protection General electronics
Number of poles	1 - 3; 1 + N; 3 + N					
Standards	IEC 60898-1, DIN EN 60898-1, VDE 0641-11, UL 508, CSA-22.2 No.14					
Interrupting capacity	see data sheet for use in the USA, Canada and Europe (page 38)					
Current limiting class	3	3				
Max. back-up fuse	see data sheet for use in the USA, Canada and Europe (page 38)					
Rated voltage AC	277 / 480 V					
Rated voltage DC L/R = 4 ms	1-pole 42 V and 2-poles 80 V in serial connection of both poles (up to 25 A rated current)					
	1-pole 24 V and 2-poles 60 V in serial connection of both poles (30 A - 60 A rated current)					
Rated current range	1 - 63* A	0.3 - 63* A	0.3 - 63* A	0.3 - 63* A	0.3 - 63* A	0.3 - 50 A
Test currents	Thermal not tripping $I_1 (A) > 1 \text{ h}$	$1.13 \times I_N$	$1.13 \times I_N$	$1.13 \times I_N$	$1.05 \times I_N$	$1.05 \times I_N$
	Thermal tripping $I_2 (A) < 1 \text{ h}$	$1.45 \times I_N$	$1.45 \times I_N$	$1.45 \times I_N$	$1.35 \times I_N$	$1.35 \times I_N$
	Electromagnetic not tripping $I_4 (A) > 0,1 \text{ s}$	$3 \times I_N$	$5 \times I_N$	$10 \times I_N$	$14 \times I_N$	$8 \times I_N$
	Electromagnetic tripping $I_5 (A) < 0,1 \text{ s}$	$5 \times I_N$	$10 \times I_N$	$16 \times I_N$	$18 \times I_N$	$10 \times I_N$
Reference calibration temperature of the thermal tripping threshold	30° C + 5° C			20° C + 5° C		
	Influence of the ambient temperature on the thermal release threshold: Decrease of the current values with higher ambient temperature and increase with lower temperatures of approximately 5% per 10°C difference in temperature					
Frequency range of the electromagnetic trip	16 2/3 to 60 Hz With higher frequencies, the electromagnetic tripping values threshold increases by approximately a factor of 1.1 at 100 Hz; 1.2 at 200 Hz; 1.3 at 300 Hz; 1.4 at 400 Hz; 1.5 for DC					
Ambient temperature	-25 °C to +55 °C					
Storage temperature	-40 °C to +70 °C					
Device depth according to DIN 43880	68 mm					
Mechanical life	10,000 switching cycles (ON / OFF)					
Protection cover	Finger safe and safe to back of hand according to DIN EN 50274/ VDE0660-514, BGV A3					
Insulation group acc. to DIN/VDE 0110	C at 250 V AC B at 400 V AC					
Degree of protection acc. to EN/IEC 60529	IP20					
Installation position	any					
Mounting	DIN-rail according to DIN EN 60715 35 mm					
Lockability	The handle can be secured against manual switching in the on and off position by a lead seal					
Climatic resistance	Humid heat constant according to DIN EN 60068-2-78 Humid heat cycle according to DIN EN 60068-2-30					
Vibration resistance	> 15 g according to DIN EN 60068-2-59 during a load with I1					
Resistance to mechanical shocks	25g 11ms					

* 63 A without UL approval



SWITCHING DEVICES MANUAL MOTOR CONTROLLER

according to UL 508 and CSA-22.2 No.14 · Technical Data Product Range UM

Type of conductor *)	Conductor cross sections			
	Box terminal bottom		Box terminal top	
	max.	min.	max.	min.
Single wire	35 mm ² (AWG2)	1.0 mm ² (AWG18)	25 mm ² (AWG3)	1.0 mm ² (AWG18)
Multiple wire	35 mm ² (AWG2)	16 mm ² (AWG6)	25 mm ² (AWG3)	16 mm ² (AWG6)
Stranded wire	25 mm ² (AWG3)	1.0 mm ² (AWG18)	16 mm ² (AWG6)	1.0 mm ² (AWG18)
Stranded wire with ferrule	16 mm ² (AWG6)	1.0 mm ² (AWG18)	16 mm ² (AWG6)	1.0 mm ² (AWG18)
Busbar cable lug	up to 3 mm thickness		up to 1.5 mm thickness	
Combined, conductor and busbar or cable lug	up to 35 mm ² and up to 2 mm thickness		not possible	
Torque	max. 2.3 Nm (20 lb.in)			

*) Stripped length: bottom 12 - 14 mm, top 10 - 12 mm

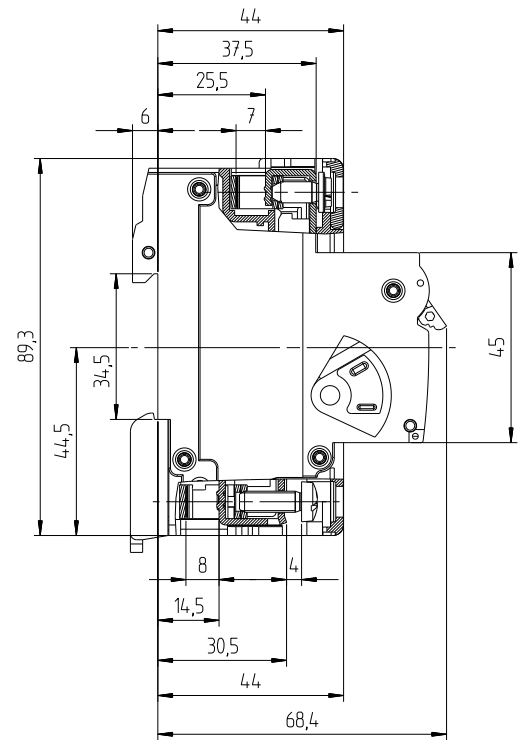
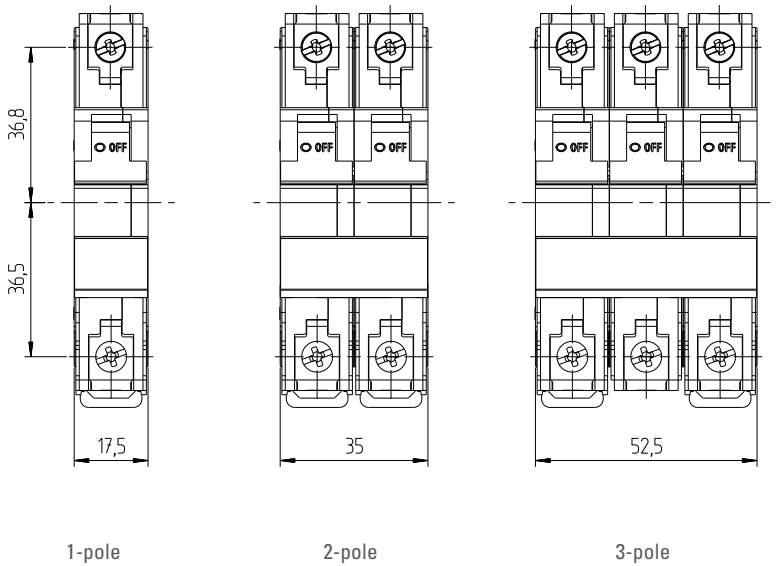

SWITCHING DEVICES MANUAL MOTOR CONTROLLER

according to UL 508 and CSA-22.2 No.14 · Technical Data Product Range UM

Interrupting capacity and maximum back-up fuse according to UL 508 and CSA-22.2 No.14					
Characteristic	B; C; D; E; G and Z				
Standards	UL 508 and CSA-22.2 No.14				
	Number of poles	Maximum rated voltage V	Rated current A	Interrupting capacity kA	Maximum back-up fuse A
Interrupting capacity at rated voltage Ambient temperature 40 °C	1 / 1 + N	277	0.3 - 10	10	70 A
	1 / 1 + N	277	12 - 60	10	4 x I _N
	2 / 3 / 3 + N	480	0.3 - 10	10	70 A
	2 / 3 / 3 + N	480	12 - 60	10	4 x I _N
Back-up fuse for group installations	1 / 1 + N	277	0.3 - 10	10	800 A
	1 / 1 + N	277	12 - 60	5	800 A
	2 / 3 / 3 + N	480	0.3 - 10	10	800 A
	2 / 3 / 3 + N	480	12 - 60	5	800 A

Interrupting capacity and maximum back-up fuse according to EN and IEC					
Characteristic	B; C; D; E; G and Z				
Standards	IEC 60947-2, DIN EN 60947-2, VDE 0660-101 B, C and D characteristic acc. to IEC 60898-1, DIN EN 60898-1, VDE 0641-11				
	Number of poles	Maximum rated voltage V	Rated current A	Interrupting capacity kA	Maximum back-up fuse A
Interrupting capacity at rated voltage	1 / 1 + N	277	0.3 - 60	10	160
	2 / 3 / 3 + N	480	0.3 - 60	10	160

Internal Resistance for Product Ranges UM and UR						
Rated current [A]	Trip characteristic]					
	B [Ohm]	C [Ohm]	D [Ohm]	G [Ohm]	E [Ohm]	Z [Ohm]
0.3		16.8620	16.8620	16.862	14.52000	31.5060
0.5		6.8540	6.0009	6.854	5.92000	10.2460
0.75/0.8		3.0540	3.0540	3.054	2.70000	5.3920
1.0	1.7000	1.7000	1.7560	1.756	1.48000	2.6910
1.6	0.5870	0.5870	0.5870	0.587	0.57400	0.9440
2.0	0.4190	0.4190	0.4190	0.419	0.40500	0.8900
2.5	0.2950	0.2950	0.2950	0.295	0.26900	0.4290
3.0	0.2020	0.2020	0.2020	0.202	0.18600	0.3460
3.5	0.1390	0.1390	0.1390	0.139	0.13900	0.1790
4.0	0.1090	0.1090	0.1090	0.109	0.10600	0.1620
5.0	0.0654	0.0654	0.0654	0.0654	0.05900	0.1050
6.0	0.0528	0.0528	0.0491	0.0491	0.04600	0.0823
8.0		0.0278	0.0240	0.0333	0.03040	0.0371
10	0.0216	0.0216	0.0187	0.0211	0.02020	0.0278
12				0.0084	0.00724	0.0151
13	0.0113	0.0084	0.0085	0.0084	0.00724	0.0151
15/16	0.0085	0.0085	0.0076	0.0076	0.00731	0.0114
20	0.0067	0.0067	0.0064	0.0064	0.00582	0.0075
25	0.0050	0.0050	0.0041	0.0046	0.00411	0.0050
30/32	0.0032	0.0032	0.0027	0.003	0.00272	0.0032
40	0.0025	0.0025	0.0022	0.0022	0.00212	0.0022
50	0.0019	0.0019	0.0018	0.0019	0.00184	0.0020
60/63 *	0.0018	0.0018	0.0017	0.00179	0.00172	—

* 63 A without UL approval



SWITCHING DEVICES MANUAL MOTOR CONTROLLER

according to UL 508 and CSA-22.2 No.14 · Technical Data Product Range UM

Ampere rating and horsepower rating 1 phase								
			FLA and LRC horsepower conversion table; use FLA and LRC ratings where no hp rating is given					
Rated current [A] (see Note 1)	Motor nameplate FLA rating [A]	Motor nameplate Starting/ LCR rating [A]	Nominal circuit voltage					
			110 – 120 VAC [hp]	200 VAC [hp]	208 VAC [hp]	220 – 240 VAC [hp]	265 VAC [hp]	277 VAC [hp]
0.30	0.30	1.80						
0.50	0.50	3.00						
0.75	0.75	4.35						
0.80	0.80	4.8						
1.0	1.0	6.0						
1.6	1.6	9.6						
2.0	2.0	12.0				$\frac{1}{6}$	$\frac{1}{6}$	$\frac{1}{6}$
2.5	2.5	15.0		$\frac{1}{6}$	$\frac{1}{6}$	$\frac{1}{6}$	$\frac{1}{6}$	$\frac{1}{4}$
3.0	3.0	18.0		$\frac{1}{6}$	$\frac{1}{6}$	$\frac{1}{4}$	$\frac{1}{4}$	$\frac{1}{3}$
3.5	3.5	21.0		$\frac{1}{4}$	$\frac{1}{4}$	$\frac{1}{4}$	$\frac{1}{3}$	$\frac{1}{3}$
4.0	4.0	24.0		$\frac{1}{4}$	$\frac{1}{3}$	$\frac{1}{3}$	$\frac{1}{3}$	$\frac{1}{3}$
5.0	5.0	30.0	$\frac{1}{6}$	$\frac{1}{3}$	$\frac{1}{2}$	$\frac{1}{2}$	$\frac{1}{2}$	$\frac{1}{2}$
6.0	6.0	36.0	$\frac{1}{4}$	$\frac{1}{2}$	$\frac{1}{2}$	$\frac{1}{2}$	$\frac{3}{4}$	$\frac{3}{4}$
8.0	8.0	48.0	$\frac{1}{3}$	$\frac{3}{4}$	$\frac{3}{4}$	1	1	1
10.0	10	60.0	$\frac{1}{2}$	1	1	1 $\frac{1}{2}$	1 $\frac{1}{2}$	2
12.0	12.0	72.0	$\frac{1}{2}$	1 $\frac{1}{2}$	1 $\frac{1}{2}$	2	2	2
12.5	12.5	75.0	$\frac{1}{2}$	1 $\frac{1}{2}$	1 $\frac{1}{2}$	2	2	2
13.0	13.0	78.0	$\frac{1}{2}$	1 $\frac{1}{2}$	1 $\frac{1}{2}$	2	2	2
15.0	15.0	90.0	$\frac{3}{4}$	2	2	2	3	3
16.0	16.0	96.0	1	2	2	2	3	3
20.0	20.0	120.0	1 $\frac{1}{2}$	3	3	3	3	3
25.0	25.0	150.0	2	3	3	3	5	5
30.0	30.0	180.0	2	3	3	5	5	5
32.0	32.0	192.0	2	3	5	5	5	5
40.0	40.0	240.0	3	5	7 $\frac{1}{2}$	7 $\frac{1}{2}$	7 $\frac{1}{2}$	7 $\frac{1}{2}$
50.0	50.0	300.0	3	7 $\frac{1}{2}$	10	10	10	10
60.0	60.0	360.0	5	10	10	10	10	15

Note 1
For AC motor circuit nameplate full load current, AC general-use loads,
AC resistance loads, AC incandescent lamp (tungsten) loads,
AC electric discharge lamp (ballast) loads

Note 2
Conversions per UL 508 Table 45.2 and NFPA-70:
National Electrical Code® 2008 Tables 430-248 and 430-251(A)



SWITCHING DEVICES MANUAL MOTOR CONTROLLER

according to UL 508 and CSA-22.2 No.14 · Technical Data Product Range UM

Ampere rating and horsepower rating 3 phase and 2 phase – 4 wire													
			FLA and LRC horsepower conversion table; use FLA and LRC ratings where no hp rating ist given										
Rated current [A] (see Note 1)	Motor nameplate FLA rating [A]	Motor nameplate Starting/ LCR rating [A]	Nominal circuit voltage										
			110 – 120 VAC		200 VAC		208 VAC		220 – 240 VAC		440 – 480 VAC		
			Motordesign		Motordesign		Motordesign		Motordesign		Motordesign		
			B, C, D [hp]	E [hp]	B, C, D [hp]	E [hp]	B, C, D [hp]	E [hp]	B, C, D [hp]	E [hp]	B, C, D [hp]	E [hp]	
0.30 0.50 0.75	0.30 0.50 0.75	3.0 5.0 7.5											
0.80 1.0 1.6	0.80 1.0 1.6	8.0 10.0 16.0										1/2	1/2
2.0 2.5 3.0	2.0 2.5 3.0	20.0 25.0 30.0			1/2 1/2	1/2 1/2	1/2 1/2	1/2 1/2	1/2 1/2	1/2 1/2	1/2 1/2	3/4 1 1 1/2	3/4 1 1 1/2
3.5 4.0	3.5 4.0	35.0 40.0			1/2 3/4	1/2 3/4	3/4 3/4	3/4 3/4	3/4 3/4	3/4 3/4	2 2	2 2	
5.0 6.0 8.0	5.0 6.0 8.0	42.0 50.4 67.2	1/2 1/2 3/4	1/2 1/2 3/4	1 1 2	1 1 2	1 1 2	1 1 2	1 1 2	1 1 2	1 1 2	3 3 5	3 3 5
10.0 12.0 12.5	10.0 12.0 12.5	84.0 100.8 105.0	1 1 1/2 1 1/2	1 1 1/2 1 1/2	2 3 3	2 3 3	2 3 3	2 3 3	3 3 3	3 3 3	3 3 3	5 7 1/2 7 1/2	5 7 1/2 7 1/2
13.0 15.0 16.0	13.0 15.0 16.0	109.2 126.0 134.4	1 1/2 2 2	1 1/2 2 2	3 3 3	3 3 3	3 3 3	3 3 3	3 3 5	3 3 5	3 3 5	7 1/2 10 10	7 1/2 10 10
20.0 25.0	20.0 25.0	168.0 210.0	3 3	3 3	5 5	5 5	5 7 1/2	5 7 1/2	5 7 1/2	5 7 1/2	5 7 1/2	10 15	10 15
30.0	30.0	252.0	5	5	5	5	7 1/2	7 1/2	10	10	10	20	20
32.0	32.0	268.8	5	5	5	5	10	10	10	10	10	20	20
40.0	40.0	226.0	5	5	10	7 1/2	10	7 1/2	10	10	10	30	20
50.0 60.0	50.0 60.0	282.5 339.0	7 1/2 10	7 1/2 10	15 15	10 10	15 20	10 10	15 20	10 15	10 15	30 40	25 30

Note 1:
For AC motor circuit nameplate full load current, AC general-use loads,
AC resistance loads, AC incandescent lamp (tungsten) loads,
AC electric discharge lamp (ballast)loads

Note 2:
Conversions per UL 508 proposed Tables 45.2 and 45.4 and NFPA-70:
National Electrical Code® 2008 Tables 430-249, 430-250 and 430-251B)



SWITCHING DEVICES MANUAL MOTOR CONTROLLER

according to UL 508 and CSA-22.2 No.14 · Characteristic Product Range UM

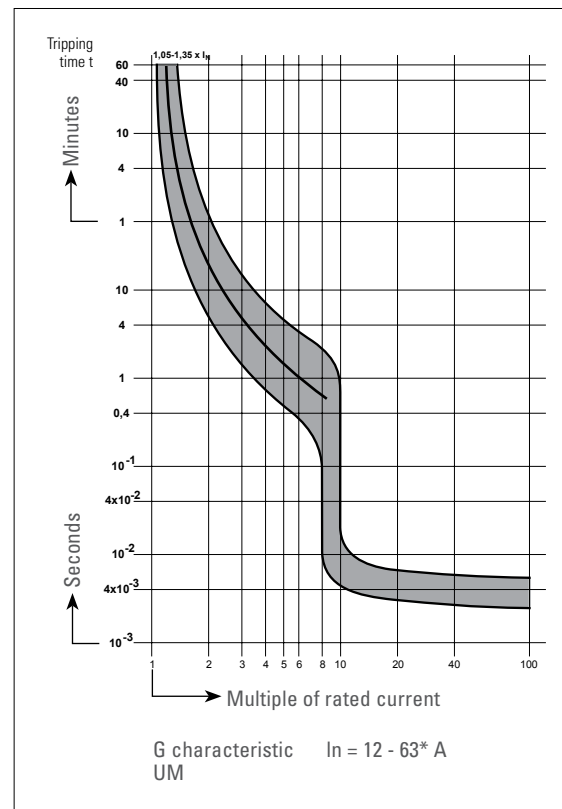
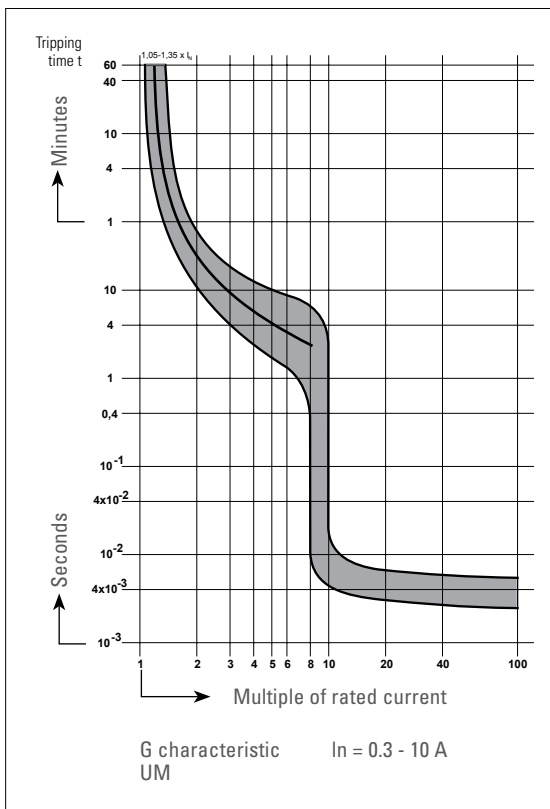
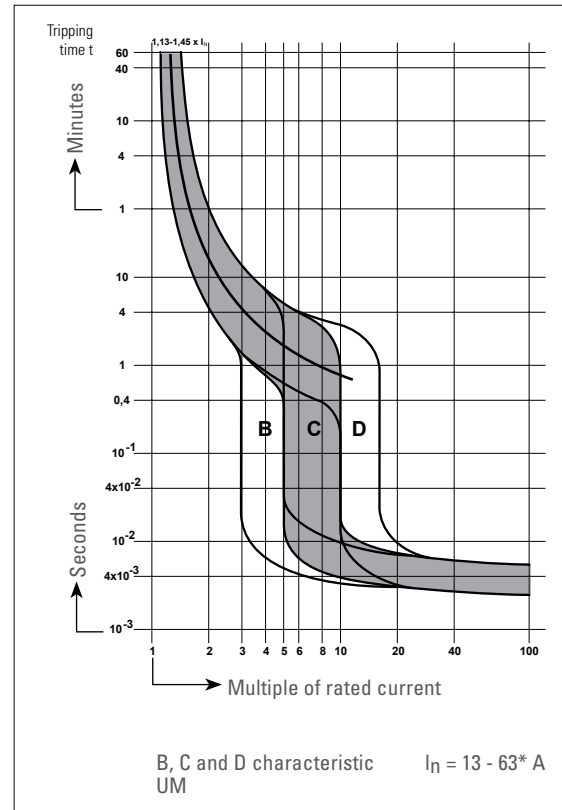
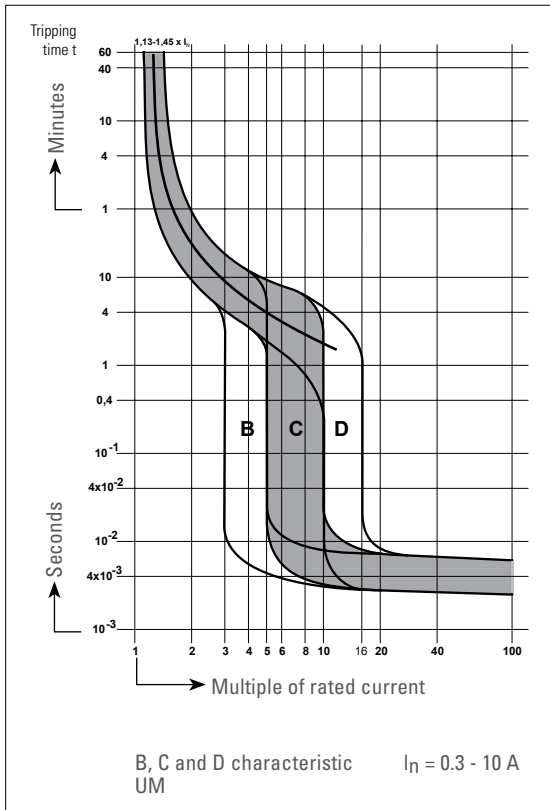

* 63 A without UL approval

SWITCHING DEVICES MANUAL MOTOR CONTROLLER

according to UL 508 and CSA-22.2 No.14 · Characteristic Product Range UM

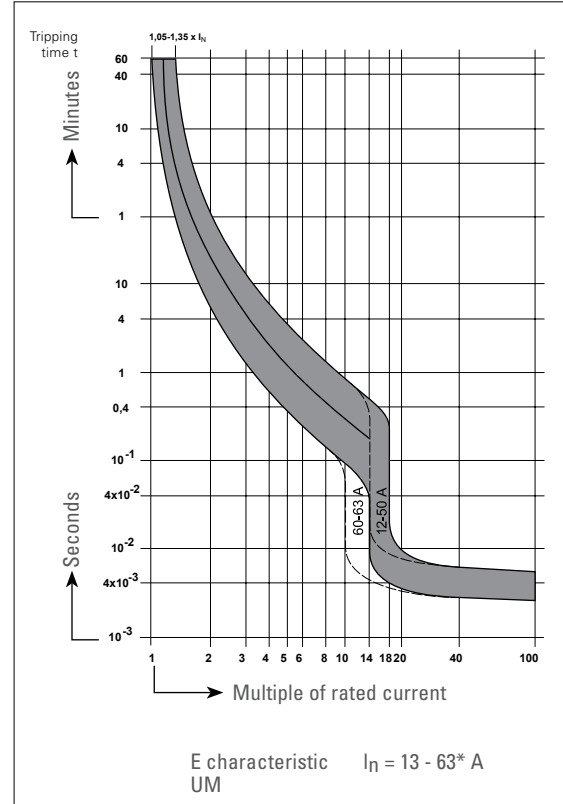
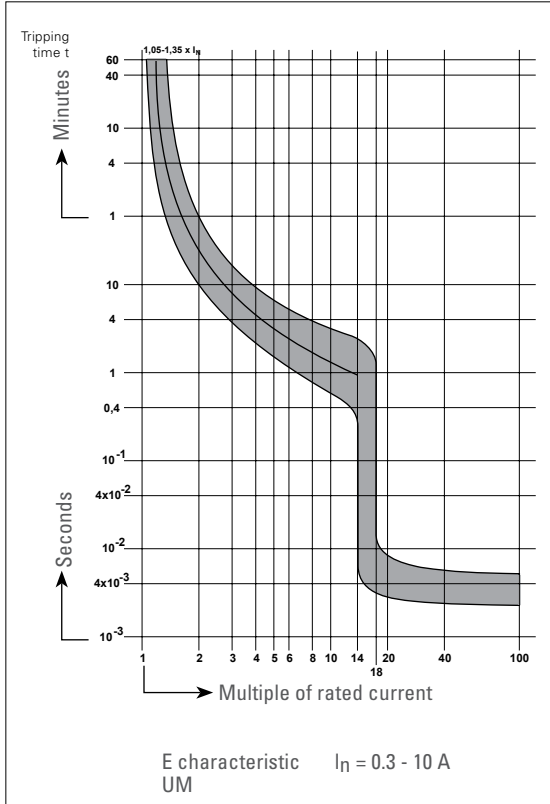

SWITCHING DEVICES MANUAL MOTOR CONTROLLER

according to UL 508 and CSA-22.2 No.14 · Characteristic Product Range UM

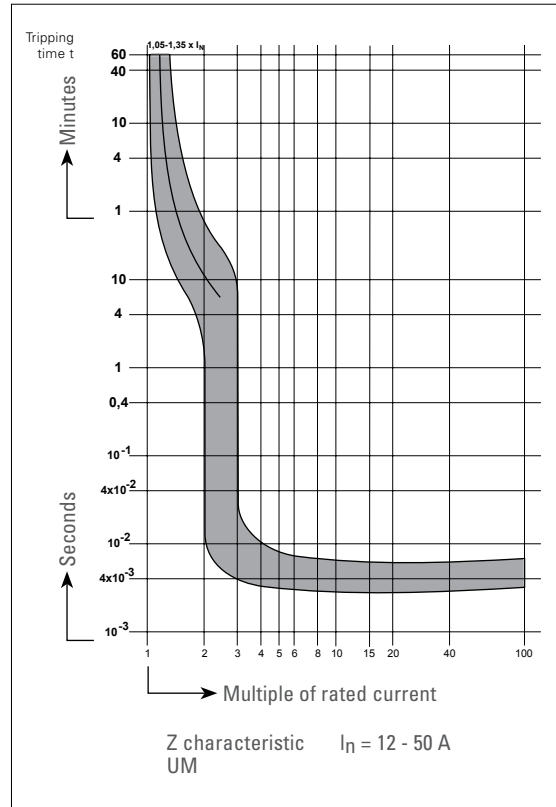
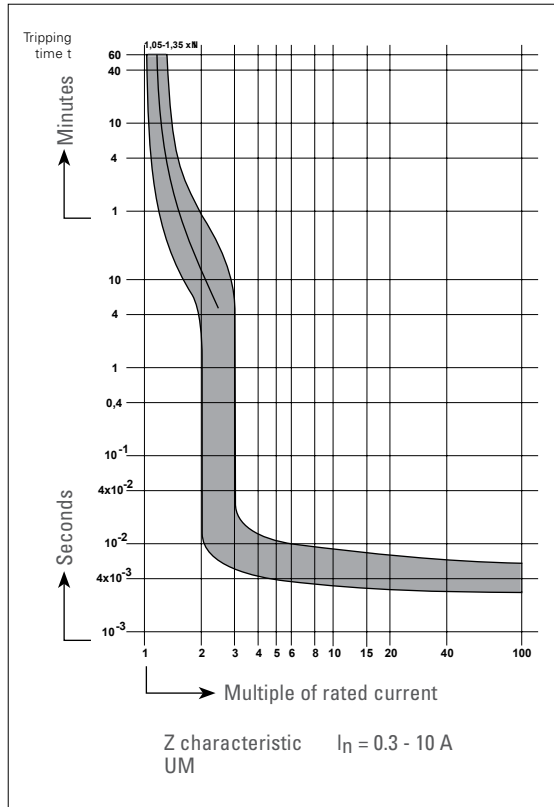



MANUAL MOTOR CONTROLLER MA

EXTENSIVELY TESTED
FOR PRACTICAL USE
ABL SURSUM SWITCHING DEVICES
COMPLIANT WITH UL 508
AND CSA-22.2 NO.14

The manual motor controller MA combines the miniature circuit breaker design with the traditional features of a manual motor controller. The adjustable calibration of the thermal tripping threshold in the IEC nominal rating ranges comprises currents up to 40 A. It was designed to handle high inrush loads from e.g. power supplies or motors. Wiring and equipment can be protected from damage by overcurrent and nuisance tripping resulting from high inrush currents can be reduced significantly. This device is available both in an IEC approved version and in an UL approved version.

The concept and design principles of the MS manual motor controller have proven their reliability over 40 years of application all around the world. It is still one of the most commonly used types of manual motor starters for single motor protection in the world. These starters are equipped with phase failure sensitivity, isolating and main switch functions. In combination with the emergency push button, they offer a simple, convenient and complete solution for all types of machinery. The wide range of accessories such as undervoltage release, shunt trip and auxiliary contacts offer enhanced monitoring and control. Its universal design and years of production history make it the ideal spare part for the millions of machines fitted with such a device all over the world.

SWITCHING DEVICES MANUAL MOTOR CONTROLLER MA

Overview

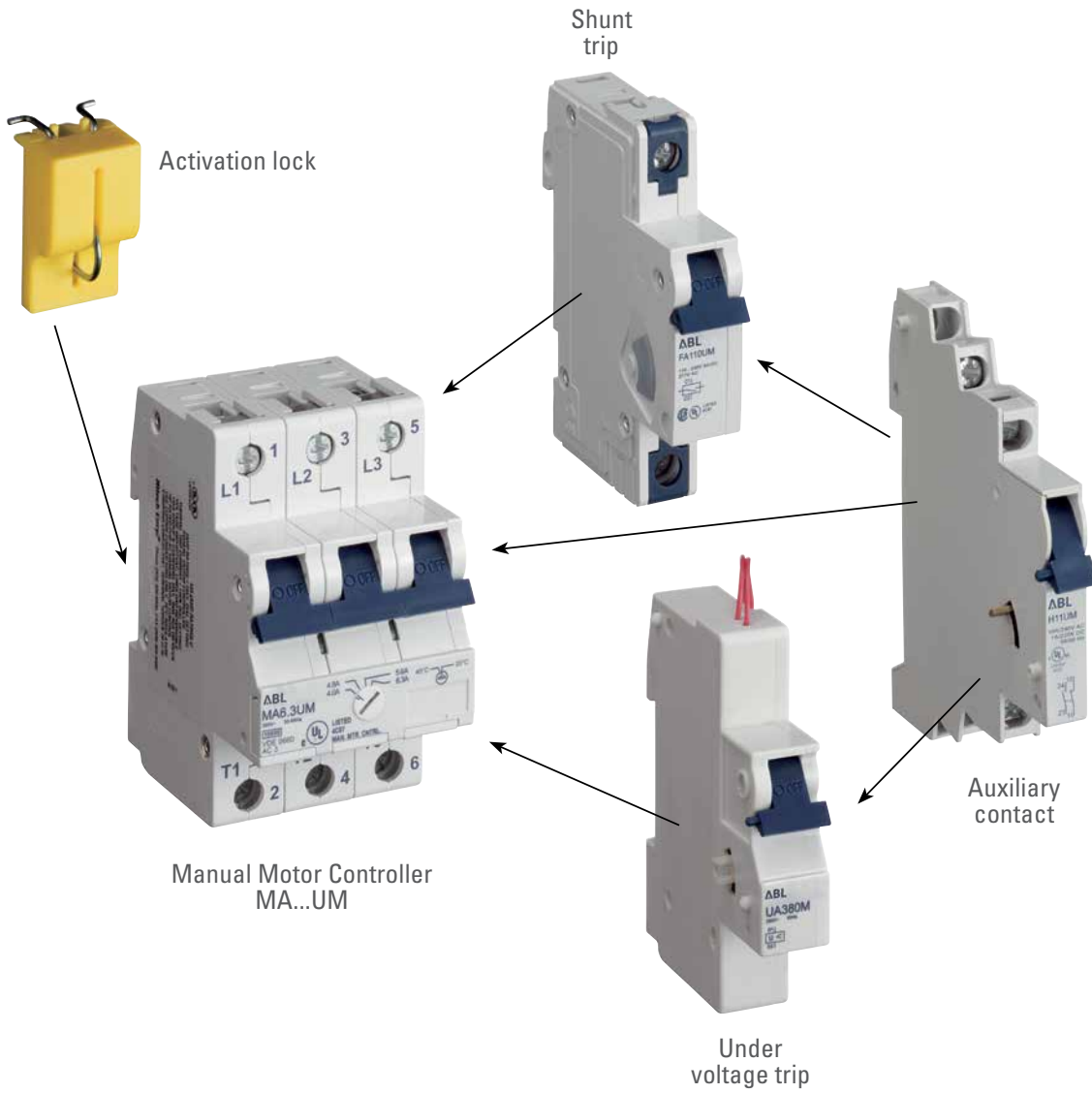

SWITCHING DEVICES MANUAL MOTOR CONTROLLER MA

according to UL 508 and CSA-22.2 No. 14 · Product Range MA...UM

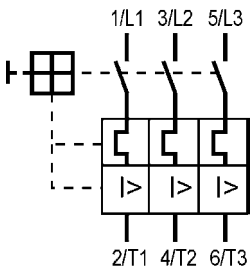

RATED CURRENT [A]	HORSEPOWER RATINGS AT NORMAL LINE VOLTAGE					OPERATING CURRENT SHORT CIRCUIT TRIP [A]	ITEM NO.	WEIGHT G/EACH	PACKING UNIT
	110-120 V HP (KW)	200V HP (KW)	208 V HP (KW)	220-240 V HP (KW)	460-480 V HP (KW)				

0.1 – 0.16	Full-load-ampere rated for motor circuits having an amperage (FLA) not exceeding the MA's general purpose rated current and a locked rotor current not exceeding 6 times the MA's rated current. Rated current equals maximum dial setting.					1.92	MA016UM	450	1
0.16 – 0.25						3.00	MA025UM	450	1
0.25 – 0.40						4.80	MA040UM	450	1
0.40 – 0.63						7.60	MA063UM	450	1
0.63 – 1.0						12.00	MA1.0UM	450	1
1.0 – 1.6						19.20	MA1.6UM	450	1
1.6 – 2.5						30.00	MA2.5UM	450	1
2.5 – 4.0	½ (0.37)	¾ (0.56)	¾ (0.56)	1 (0.75)	2 (1.5)	48.00	MA4.0UM	450	1
4.0 – 6.3	¾ (0.56)	1½ (1.2)	1½ (1.2)	1 (0.75)	3 (2.24)	75.60	MA6.3UM	450	1
6.3 – 10	1 (0.75)	2 (1.5)	2 (1.5)	3 (2.24)	5 (3.73)	120.00	MA10UM	450	1
10 – 16	2 (1.5)	3 (2.24)	3 (2.24)	5 (3.73)	10 (7.46)	192.00	MA16UM	450	1
16 – 20	3 (2.24)	5 (3.73)	5 (3.73)	5 (3.73)	10 (7.46)	240.00	MA20UM	450	1
20 – 25	3 (2.24)	5 (3.73)	7½ (5.6)	7½ (5.6)	15 (11.19)	300.00	MA25UM	450	1
25 – 32	5 (3.73)	7½ (5.6)	7½ (5.6)	10 (7.46)	20 (14.92)	240.00	MA32UM	450	1
32 – 40	5 (3.73)	10 (7.46)	10 (7.46)	10 (7.46)	25 (18.65)	300.00	MA40UM	450	1



ACCESSORIES FOR SWITCHING DEVICES

Manual Motor Controller MA

according to UL 508 and CSA-22.2 No.14 for Product Ranges UM and MA...UM



Shunt trip

MODULE	RATED OPERATING VOLTAGE	MAX. OPERATING CURRENT AT UN (T < 10 MS)	ITEM NO.	WEIGHT G/EACH	PACKING UNIT
1	12 V \approx	1.3 A	FA12UM	105	5
1	24 V \approx	0.6 A	FA24UM	105	5
1	48 - 72 V \approx	0.2 A	FA48UM	105	5
1	110 - 240 V \approx , 415 V \sim	0.25 A at 110 V 0.5 A at 240 V 0.58 A at 277 V	FA110UM	105	5
Pull-in voltage 0.7 x U _e		duty cycle at rated operating voltage: 100%			



Auxiliary contact

MODULE	TYPE OF CONTACT	CONTACTS	ITEM NO.	WEIGHT G/EACH	PACKING UNIT
1/2	1 auxiliary contact	1NO	H10UM	35	10
1/2	2 auxiliary contacts	1NO + 1NC	H11UM	40	10
1/2	3 auxiliary contacts	1NO + 2NC	H12UM	45	10
1/2	3 auxiliary contacts	2NO + 1NC	H21UM	45	10

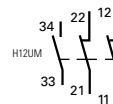

Standards	according to IEC 60947-5-1, DIN EN 60947-5-1, VDE 0660-200, UL 508	
Rated operating currents	10 A / 240 V AC 3 A / 110 V DC 1 A / 220 V DC	
Minimum contact load	1 mA at 24 V DC	
Conductor cross sections		
Type of conductor *)	min.	max.
Single wire	1.0 mm ² (AWG18)	2.5 mm ² (AWG14)
Stranded wire	1.0 mm ² (AWG18)	1.5 mm ² (AWG16)
Stranded wire with ferrule	1.0 mm ² (AWG18)	1.5 mm ² (AWG16)
Torque	max. 0.8 Nm (7 lb.in)	

*) Stripped length 8 - 9 mm

ACCESSORIES FOR SWITCHING DEVICES

Manual Motor Controller MA

according to UL 508 and CSA-22.2 No.14 for Product Ranges UM and MA...UM

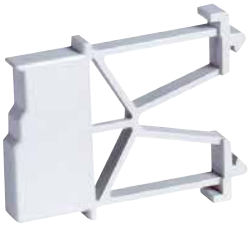

SPACER 9 MM

MODULE	ITEM NO.	WEIGHT G/EACH	PACKING UNIT
1/2	HDS	7	10



ACTIVATION LOCK

For miniature circuit breakers and motor protective circuit breakers

	ITEM NO.	WEIGHT G/EACH	PACKING UNIT
	EASS	4	10

VARIOUS BUSBARS

see page 59



SWITCHING DEVICES MANUAL MOTOR CONTROLLER MA

according to UL 508 and CSA-22.2 No.14 · Technical Data Product Range MA...UM

Technical Data		
Standards	UL 508 and CSA-22.2 No.14	
Interrupting capacity	0.16 A – 2.5 A / 42 kA, 4 A – 16 A / 14 kA, 20 – 40 A / 10 kA	
Utilization category	AC 3 at U_e 415 V~ (up to I_n 25 A)	
Group Short Circuit Ratings (UL/CSA Ratings)	1200 A / 42 kA, 350 A / 14 kA, 350 A / 10 kA	
Rated voltage AC	480Y / 277 VAC	
Rated current range	15 setting ranges from 0.1 up to 40 A	
Rated uninterrupted current I_{th}	40 A	
Tripping time at $6 \times I_e$	> 5s/TII	
Test currents	Thermal not tripping I_1 (A) > 2 h	$1.05 \times I_e$
	Thermal tripping I_2 (A) < 2 h	$1.15 \times I_e$
	Electromagnetic not tripping I_4 (A) > 0.1 s	for the lower setting $16 \times I_e$ ($12.5 \times I_e > 16$ A) for the upper setting $10 \times I_e$
	Electromagnetic tripping I_5 (A) < 0.1 s	for the lower setting $19 \times I_e$ ($15 \times I_e > 16$ A) for the upper setting $12 \times I_e$
Temperature compensation	up to +40 °C	
Permitted ambient temperature	open -20 °C to +50 °C, enclosure -20 °C to +40 °C storage/transport -40 °C to +70 °C	
Device depth according to DIN 43880	68 mm	
Mechanical endurance	30 000 switching cycles (30 000 ON / 30 000 OFF)	
Permitted operating frequency	30 switching cycles/h	
Protection cover	Safe for fingers and back of hand acc. to DIN EN 50274, VDE 0660-514	
Degree of protection according to EN/IEC 60529	IP20	
Installation position	any	
Mounting	On DIN-rail acc. to DIN EN 60715 35 mm	
Lockability	The handle can be secured against manual switching in the ON and OFF position by a lead seal	
Climatic resistance	Humid heat constant according to DIN IEC 60068-2 – 78 Humid heat cyclic according to DIN EN 60068-2 – 30	
Vibration resistance	> 15 g according to DIN EN 60068-2 – 59 for a load with I_1	
Resistance to mechanical shocks	25 g 11 ms	



SWITCHING DEVICES MANUAL MOTOR CONTROLLER MA

according to UL 508 and CSA-22.2 No.14 · Technical Data Product Range MA...UM

Conductor cross sections				
Type of conductor *)	Box terminal bottom		Box terminal top	
	max.	min.	max.	min.
Single wire	25 mm ² (AWG3)	1.0 mm ² (AWG18)	25 mm ² (AWG3)	1.0 mm ² (AWG18)
Multiple wire	25 mm ² (AWG3)	16 mm ² (AWG6)	25 mm ² (AWG3)	16 mm ² (AWG6)
Stranded wire	16 mm ² (AWG6)	1.0 mm ² (AWG18)	25 mm ² (AWG3)	1.0 mm ² (AWG18)
Stranded wire with ferrule	16 mm ² (AWG6)	1.0 mm ² (AWG18)	16 mm ² (AWG6)	1.0 mm ² (AWG18)
Busbar	up to 3 mm thickness		up to 1.5 mm thickness	
Cable lug	up to 3 mm thickness		up to 1.5 mm thickness	
Combined, conductor and busbar or cable lug	up to 25 mm ² and up to 2 mm thickness		not possible	
Torque	max. 2.3 Nm (20 lb.in)			

*) Stripped length: bottom 12 - 14 mm, top 10 - 12 mm

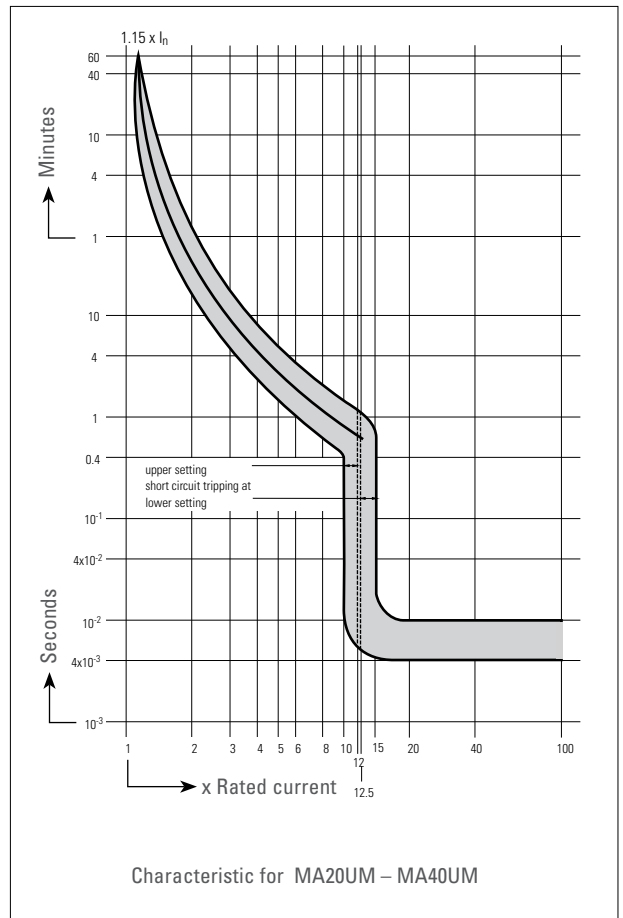
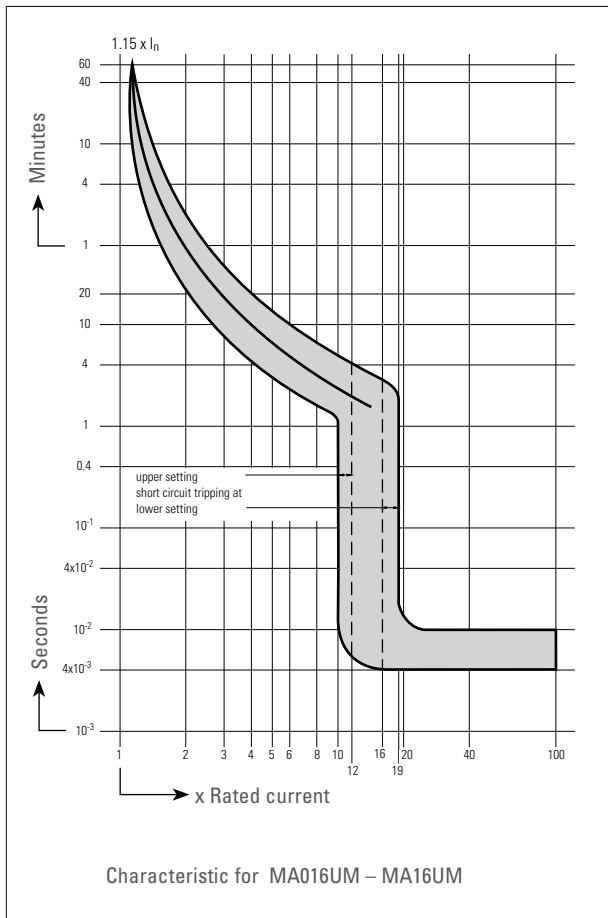

SWITCHING DEVICES MANUAL MOTOR CONTROLLER MA

according to UL 508 and CSA-22.2 No.14 · Technical Data Product Range MA...UM

Internal resistance per pole in mΩ and power loss in Watt of the complete device

TYPE	LOWER SETTING A	UPPER SETTING A	INTERNAL RESISTANCE PER POLE MΩ	POWER LOSS FOR THE COMPLETE DEVICE FOR	
				LOWER SETTING WATT	UPPER SETTING WATT
MA016UM	0.10	0.16	85500	2.6	6.6
MA025UM	0.16	0.25	35000	2.7	6.6
MA040UM	0.25	0.40	15000	2.8	7.2
MA063UM	0.40	0.63	5200	2.5	6.2
MA1.0UM	0.63	1.0	2300	2.7	6.9
MA1.6UM	1.0	1.6	950	2.9	7.3
MA2.5UM	1.6	2.5	355	2.7	6.7
MA4.0UM	2.5	4.0	142	2.7	6.8
MA6.3UM	4.0	6.3	54	2.6	6.4
MA.10UM	6.3	10	28	3.3	8.4
MA.16UM	10	16	13.9	4.2	10.7
MA.20UM	16	20	9.9	5.2	8.2
MA.25UM	20	25	6.3	8	12.3
MA.32UM	25	32	3.85	6.4	10.5
MA.40UM	32	40	3.1	8.6	13.4

TYPE	RATED CURRENT [A]	FLA DIAL ADJUSTMENT MARKINGS	GROUP SHORT CIRCUIT RATING AT 480 VAC A (AND BCP SIZE)	3 Ø HORSEPOWER RATINGS AT NOMINAL LINE VOLTAGE (SEE NOTE FOR HEA DEFINITION)				
				110 – 120 V HP (HEA)	200 V HP (HEA)	208 V HP (HEA)	220 – 240 V HP (HEA)	460 – 480 V HP (HEA)

MA016UM	0.16	0.1/ 0.12/0.14/0.16	42 KARMS symmetrical (max. 1200 A MCCB or RK5)	Through MA2.5UM, ampere rated for motor circuits having a fullload-amperage (FLA) not exceeding the MA's general purpose rated current and a lockedrotor current not exceeding 6 times the MA's rated current. Rated current equals maximum dial setting.				
MA025UM	0.25	0.16/0.19/0.22/0.25						
MA040UM	0.40	0.25/0.30/0.35/0.40						
MA063UM	0.63	0.40/0.48/0.56/0.63						
MA1.0UM	1.00	0.63/0.75/0.87/1.0						
MA1.6UM	1.60	1.0/1.2/1.4/1.6						
MA2.5UM	2.50	1.6/1.9/2.2/2.5	14 KARMS symmetrical (max. 350 A MCCB or RK5)	1/2 (4.0)	3/4 (3.2)	3/4 (3.1)	1 (3.6)	2 (3.42)
MA4.0UM	4.00	2.5/3.0/3.5/4.0		3/4 (5.6)	1 1/2 (6.0)	1 1/2 (5.7)	1 1/2 (5.2)	3 (4.8)
MA6.3UM	6.30	4.0/4.8/5.6/6.3		1 (7.2)	2 (7.8)	2 (7.5)	3 (9.6)	5 (7.6)
MA10UM	10	6.3/7.5/8.7/10	10 KARMS symmetrical (max. 350 A MCCB or RK5)	2 (13.6)	3 (11.0)	3 (10.6)	5 (15.2)	10 (14.0)
MA16UM	16	10/12/14/16		3 (19.2)	5 (17.5)	5 (16.7)	5 (15.2)	10 (14.0)
MA20UM	20	16/17/18.5/20		3 (19.2)	5 (17.5)	7 1/2 (24.2)	7 1/2 (22.0)	15 (21.0)
MA25UM	25	20/21.5/23/25		5 (30.4)	7 1/2 (25.0)	7 1/2 (24.2)	10 (28.0)	20 (27.0)
MA32UM	32	25/27/30/32	10 KARMS symmetrical (max. 350 A MCCB or RK5)	5 (30.4)	10 (32.0)	10 (31.0)	10 (28.0)	25 (34.0)
MA40UM	40	32/34/37/40		5 (30.4)	10 (32.0)	10 (31.0)	10 (28.0)	25 (34.0)

Note:
 HEA - Horsepower Equivalent Amperes, the nominal amperage assigned to standard motor horsepower ratings in design guide tables such as
 NFPA-70 Tables 430-248, 430-249, 430-250; UL 1077 Table 16.2;
 CSA - C22.2 No. 235-M89 Tables 44 and 45;
 CSA-C22.2 No. 14-M91 Table 19, etc.
 Multiply HEA values (in parenthesis) by 1.1 if power factor is 90%, and by 1.2 if power factor is 80%

a)
 The standard-circuit short-circuit rating is 14 kA for all types. Group ratings can be used in a standard circuit (e.g., MA1.0UM at 42 kA), but a higher standard rating cannot be used in a group circuit (e.g., MA40UM at 14 kA only in standard circuit.)



SWITCHING DEVICES MANUAL MOTOR CONTROLLER MA

according to UL 508 and CSA-22.2 No.14 · Dimension Drawing

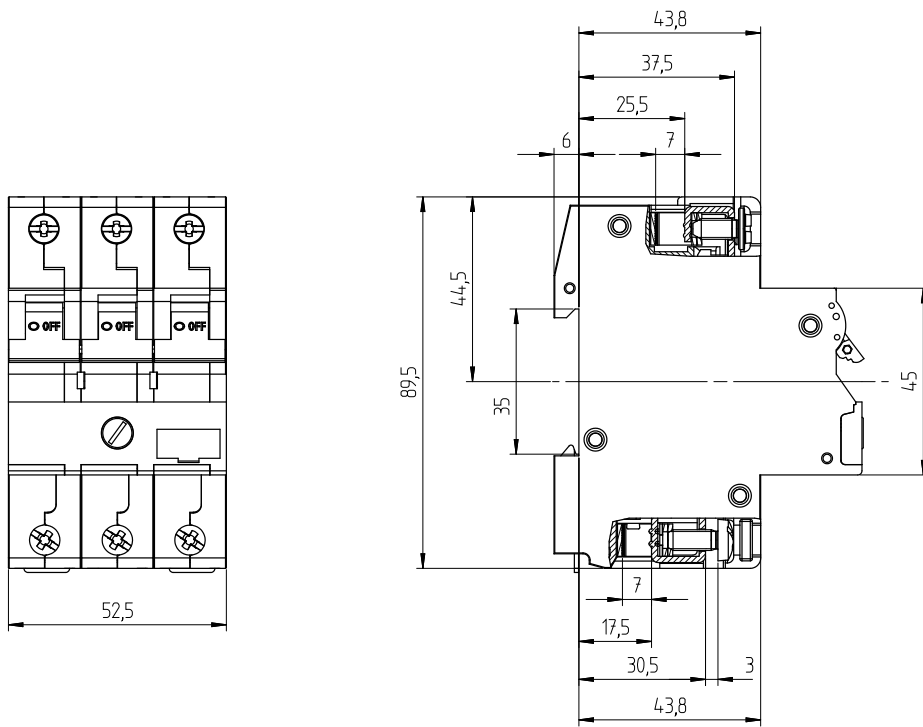

SWITCHING DEVICES MANUAL MOTOR CONTROLLER MS

Overview

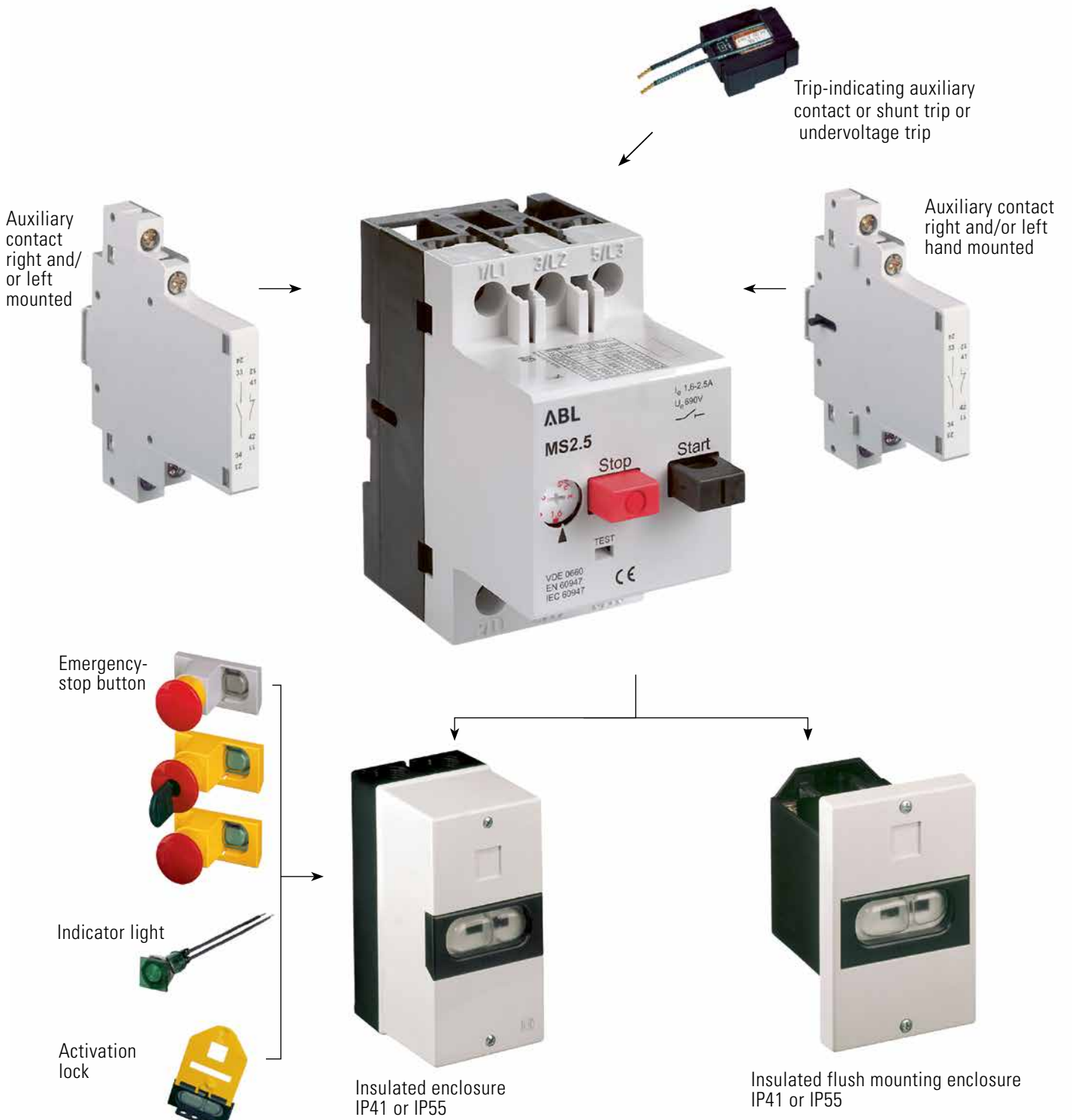

SWITCHING DEVICES MANUAL MOTOR CONTROLLER MS

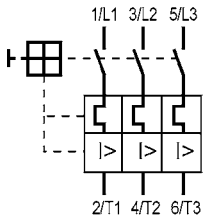

RATED CURRENT [A]	HORSEPOWER RATINGS AT NOMINAL LINE VOLTAGE					OPERATING CURRENT SHORT CIRCUIT TRIP [A]	ITEM NO.	WEIGHT G/EACH	PACKING UNIT
	115V HP (KW)	200V HP (KW)	230V HP (KW)	480V HP (KW)	600 HP (KW)				

0.1 - 0.16	Ampere rated for motor circuits having a full-load-ampere (FLA) not exceeding the MS's general purpose rated current and a locked rotor current not exceeding 6 times the MS's rated current.					1.92	MS016	250	1
0.16 - 0.25						3.00	MS025	250	1
0.25 - 0.40						4.80	MS040	250	1
0.40 - 0.63						7.60	MS063	250	1
0.63 - 1.0			1/2 (0.37)	1/2 (0.37)	12.00	MS1	250	1	
1.0 - 1.6			3/4 (0.56)	1 (0.75)	19.20	MS1.6	250	1	
1.6 - 2.5		1/2 (0.37)	1/2 (0.37)	1 (0.75)	11/2 (1.2)	30.00	MS2.5	250	1
2.5 - 4.0	1/2 (0.37)	3/4 (0.56)	1 (0.75)	2 (1.5)	3 (2.24)	48.00	MS4	250	1
4.0 - 6.3	3/4 (0.56)	1 1/2 (1.2)	1 (0.75)	3 (2.24)	5 (3.73)	75.60	MS6.3	250	1
6.3 - 10	1 (0.75)	2 (1.5)	3 (2.24)	5 (3.73)	7 1/2 (5.6)	120.00	MS10	250	1
10 - 16	2 (1.5)	3 (2.24)	5 (3.73)	10 (7.46)	10 (7.46)	192.00	MS16	250	1
16 - 20	3 (2.24)	5 (3.73)	5 (3.73)	10 (7.46)	-	240.00	MS20	250	1
20 - 25	3 (2.24)	5 (3.73)	7 1/2 (5.6)	15 (11.19)	-	300.00	MS25	250	1



ACCESSORIES FOR MANUAL MOTOR CONTROLLER MS



MODULES	WIRING DIAGRAM	CONTACTS	ITEM NO.	WEIGHT G / EACH	PACKING UNIT
---------	----------------	----------	----------	-----------------	--------------

Auxiliary contact for side mounting

1/2 M		2 NO	HMS20	40	5
1/2 M		1 NO + 1 NC	HMS11	40	5
1/2 M		1 NO	HMS10	40	5
1/2 M		2 NC	HMS02	40	5
1/2 M		1 NC	HMS01	40	5

Early make auxiliary contact for side mounting

1/2 M		1 NO + 1 NC	VHMS11	40	5
1/2 M		2 NO	VHMS20	40	5

Technical Data	HMS, VHMS
Rated impulse withstand voltage U_{imp}	4 000 V
Rated operating voltage U_e	500 V
Overtoltage category/Pollution level	III/3
Max. current (with free air circulation) I_{th}	6A
Rated operating current I_e	3.5/2 A
Can also be used for low voltage and PLC-inputs	24 V DC, 10 mA
Cross section: 1 conductor mm^2 2 conductor mm^2 only HMS, VHMS	0.75 – 2.5 r; 0.75 – 1.5 f (with ferrule) 0.75 – 2.5 r; 0.75 – 1.5 f (with ferrule)

ACCESSORIES FOR MANUAL MOTOR CONTROLLER MS

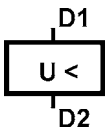
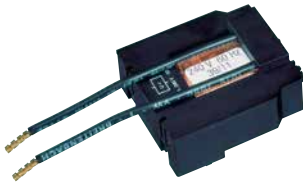
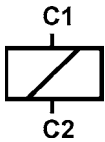

	RATED OPERATING VOLTAGE	ITEM NO.	WEIGHT G/EACH	PACKING UNIT
--	-------------------------	----------	---------------	--------------

Shunt trip for inside mounting with connecting cable (140 mm long)

	110 V 50 Hz, 120 V 60 Hz	AMS110	75	10
	220-230 V 50 Hz, 240 V 60 Hz	AMS220	75	10
	380-415 V 50 Hz, 440 V 60 Hz	AMS380	75	10
	24 V 50/60 Hz	AMS24	75	10
	500 V 50 Hz	AMS500	75	10
	24 V DC	AMSD24	75	10
Pull-in voltage $0.7 \times U_e$			Switch in duration for U_e 100% AC	

Undervoltage trip for inside mounting with connecting cable (140 mm long)

	110 V 50 Hz, 120 V 60 Hz	UMS110	75	10
	220-230 V 50 Hz, 240 V 60 Hz	UMS220	75	10
	380-415 V 50 Hz, 440 V 60 Hz	UMS380	75	10
	24 V 50/60 Hz	UMS24	75	10
	500 V 50 Hz	UMS500	75	10
Pull-in voltage $\geq 0.85 \times U_e$		Drop out voltage $0.35-0.7 \times U_e$		Switch in duration for U_e 100%



ACCESSORIES FOR MANUAL MOTOR CONTROLLER MS



INSULATED ENCLOSURE IP55

with integrated PE(N) terminal top and bottom each 2 metric knock-outs

	ITEM NO.	WEIGHT G / EACH	PACKING UNIT
	MS.G55	240	1



INSULATED FLUSH MOUNTING ENCLOSURE IP55

with integrated PE(N) terminal

	ITEM NO.	WEIGHT G / EACH	PACKING UNIT
	MS.F55	170	1



STOP BUTTON

not latching red, on grey surface

	ITEM NO.	WEIGHT G / EACH	PACKING UNIT
	MS.PT	55	5



ACTIVATION LOCK for up to three padlocks

	ITEM NO.	WEIGHT G / EACH	PACKING UNIT
	MS.VS	100	10



EMERGENCY-STOP BUTTON

latching, turn to release red, on yellow surface

	ITEM NO.	WEIGHT G / EACH	PACKING UNIT
	MS.PV	60	5



EMERGENCY-STOP BUTTON

latching, key release (2 keys) red, on yellow surface

	ITEM NO.	WEIGHT G / EACH	PACKING UNIT
	MS.PS2	65	5



INDICATOR LIGHT

with glow bulb, nominal rated voltage: 220-240 V

COLOUR	ITEM NO.	WEIGHT G / EACH	PACKING UNIT
green	MS.SLG2	10	5



INDICATOR LIGHT

with glow bulb, nominal rated voltage: 380-440 V

COLOUR	ITEM NO.	WEIGHT G / EACH	PACKING UNIT
green	MS.SLG3	10	5

ACCESSORIES FOR MANUAL MOTOR CONTROLLER MS

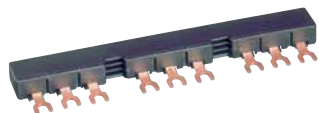

DESCRIPTION	MAX. BUSBAR CURRENT (A)	LENGTH	ITEM NO.	WEIGHT G/EACH	PACKING UNIT
-------------	-------------------------	--------	----------	---------------	--------------

Busbars					
for 2 MPCBs without auxiliary contacts	63	90 mm	SB.D02	37	10
for 3 MPCBs without auxiliary contacts	63	136 mm	SB.D03	55	10
for 4 MPCBs without auxiliary contacts	63	180 mm	SB.D04	75	10
for 2 MPCBs each with 1 auxiliary contact fitted on the right side	63	99 mm	SB.D12	40	10
for 3 MPCBs each with 1 auxiliary contact fitted on the right side	63	153 mm	SB.D13	65	10
for 4 MPCBs each with 1 auxiliary contact fitted on the right side	63	207 mm	SB.D14	90	10
for 5 MPCBs each with 1 auxiliary contact fitted on the right side	63	261 mm	SB.D15	115	10
for 2 MPCBs each with 2 auxiliary contacts	63	108 mm	SB.D22	45	10
for 4 MPCBs each with 2 auxiliary contacts	63	234 mm	SB.D24	105	10

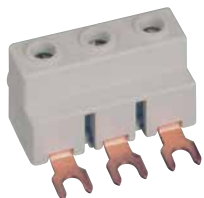

Incoming terminal block					
	63		SB.DE1	30	10



Shroud					
			SB.DA1	5	10

SWITCHING DEVICES MANUAL MOTOR CONTROLLER MS

Technical Data

Standards	IEC 60947, DIN EN 60947, VDE 0660
Mechanical endurance = Electrical endurance	0.1 x 10 ⁶ switching cycles
Max. operating frequency	30 switching cycles / h
Ambient temperature not enclosed, max./min. enclosed, max./min.	+55 °C / -20 °C +40 °C / -20 °C
Resistance to mechanical shocks	15 g / 10 ms
Installation position	any, in IP41 enclosure vertical
Cross section (1 or 2 conductors)	1.0 – 6 r; 0.75 – 4 f (with ferrule) 2 conductors differing by not more than 2 sizes
Torque for terminal screws - Main conductor - Auxiliary conductor - Auxiliary contact for front mounting	1.2 Nm 1.0 Nm 0.5 Nm
Rated impulse withstand voltage U _{imp}	6 000 V
Overvoltage category / Pollution level	III / 3
Rated operating voltage U _e	690 V AC
Rated operating current I _e	0.16 – 25 A according to setting range
Frequency	40...60 Hz
	At higher frequencies, the electromagnetic tripping threshold increases by a factor of about 1.1 at 100 Hz; 1.2 at 200 Hz; 1.4 at 400 Hz; 1.5 at 500 Hz
Utilization category (IEC 60947-4-1, DIN EN 60947-4-1, VDE 0660-102)	AC-3 max. 690 V
Temperature compensation (reference values to VDE / IEC)	-5 °C / +40 °C
Temperature compensation Operating range	-20 °C...+55 °C
Power loss in watt per current path	by min. setting range 0.6 – 1.05 W / by max. setting range 1.5 – 2.6 W

Rated interrupting capacity I _{cu} MS IEC 60947-2, DIN EN 60947-2, VDE 0660-101				
Upper setting Thermal tripping	I _{cu} (kA)			
	230 V	400 V	500 V	690 V
0.16 – 1.6 A	No additional protective devices needed inherently stable for any selected short circuit currents			
2.5 – 6.3 A			3	2.5
10 A		6	3	2.5
16 – 25 A	10	6	2.5	2



Switching times at short circuit
 minimum command time 2 ms
 opening delay 2 ms
 opening time 7 ms

SWITCHING DEVICES MANUAL MOTOR CONTROLLER MS

Technical Data

Back-up-protection MS					EN and IEC Rating			
UL and CSA Rating					Back-up fuse (gL, aM) [A]			
Type	Fuse [A]	Group Fusing [A]	Voltage [V]	Interrupting Capacity [kA]	230 V	400 V	500 V	690 V
MS016	1	100	600	5	No back-up fuse necessary. Inherently stable for any selected short circuit currents			
MS025	1	100	600	5				
MS040	1	100	600	5				
MS063	2	100	600	5				
MS1	4	100	600	5				
MS1.6	6	100	600	5				
MS2.5	10	100	600	5				
MS4	15	100	600	5				
MS6.3	25	50	600	5				
MS10	40		600	5				
MS16	60		600	5	80	80	63	35
MS20	60		480	5	80	80	63	50
MS25	70		480	5	80	80	63	50

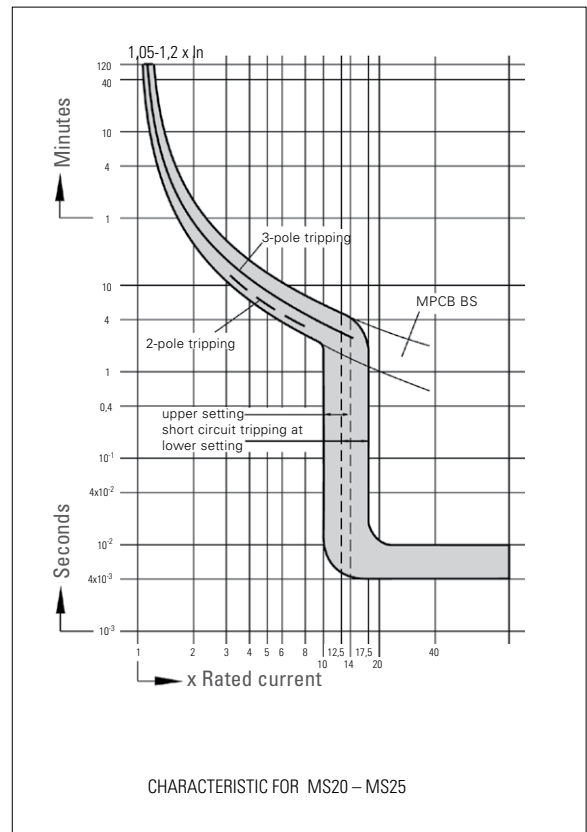
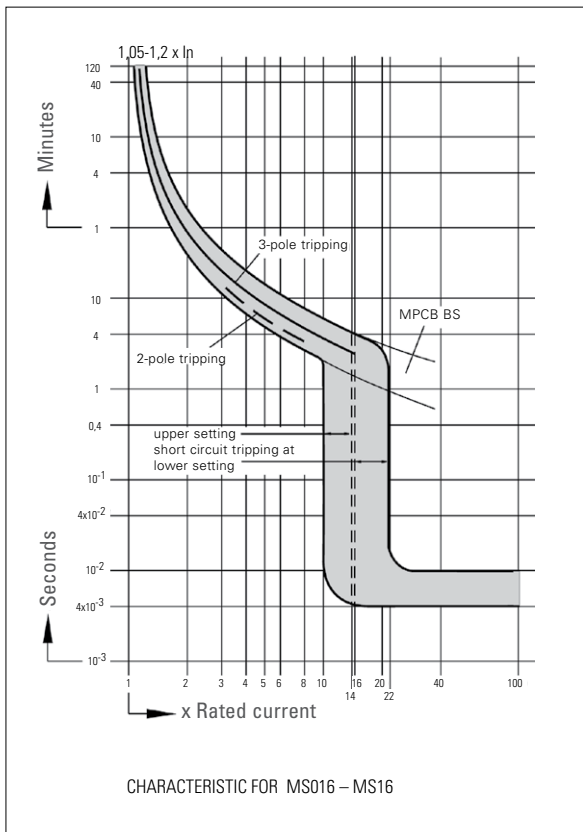

SWITCHING DEVICES MANUAL MOTOR CONTROLLER MS

Dimension Drawings

Motor protective circuit breaker MS

Mounting dimensions

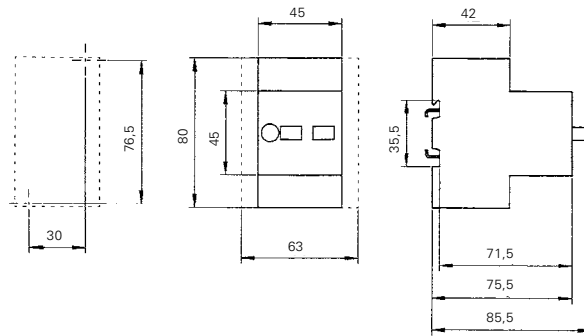

Insulated enclosure MS.G55

possible to integrate 1 MPCB
and 2 side mounted auxiliary
contacts

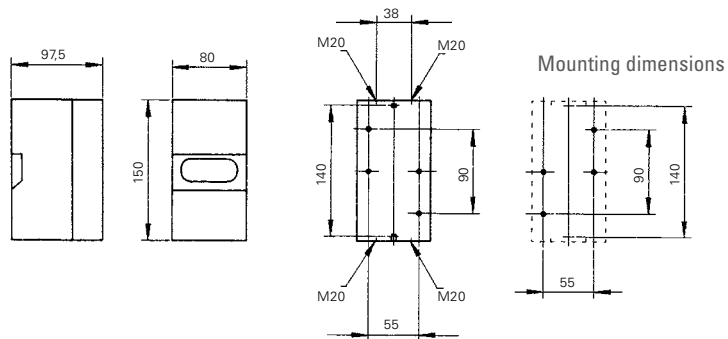

Insulated flush mounting enclosure MS.F55

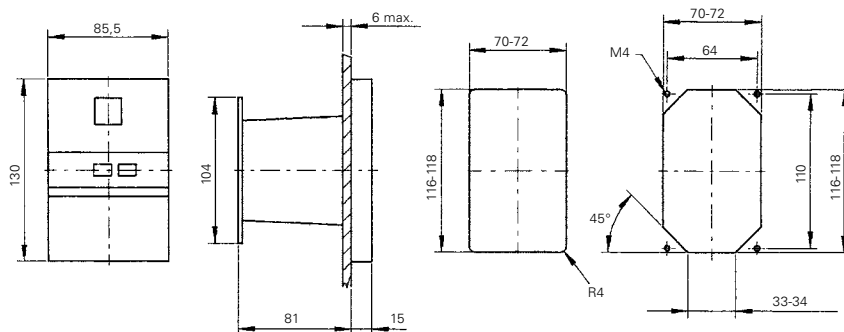

Emergency-stop button MS.PT – PS.PS2

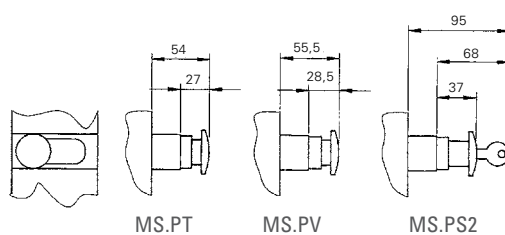

Horsepower rating and Kilowatt rating	
Horsepower [hp]	Kilowatt [kW]
0.167	0.13
0.25	0.184
0.5	0.38
0.75	0.55
1	0.735
1.25	0.919
1.5	1.103
1.75	1.287
2	1.471
2.5	1.839
3	2.206
4	2.942
5	3.677
6	4.413
7	5.148
7.5	5.516
8	5.884
9	6.619
10	7.355
11	8.09
12	8.826
13	9.561
14	10.297
15	11.032
16	11.768

Wire cross section in AWG and mm ²		
AWG No.	Cross section [mm ²]	Diameter [mm]
21	0.412	0.724
20	0.519	0.813
19	0.653	0.912
18	0.824	1.27
17	1.01	1.151
16	1.307	1.29
15	1.651	1.45
14	2.082	1.628
13	2.627	1.829
12	3.307	2.052
11	4.169	2.304
10	5.26	2.588
9	6.633	2.906
8	8.367	3.264
7	10.55	3.665
6	13.229	4.115
5	16.767	4.62
4	21.148	5.189
3	26.667	5.827
2	33.624	6.543
1	42.406	7.348
1/0	53.182	8.252
2/0	67.43	9.266
3/0	85.014	10.404
4/0	107.22	11.684

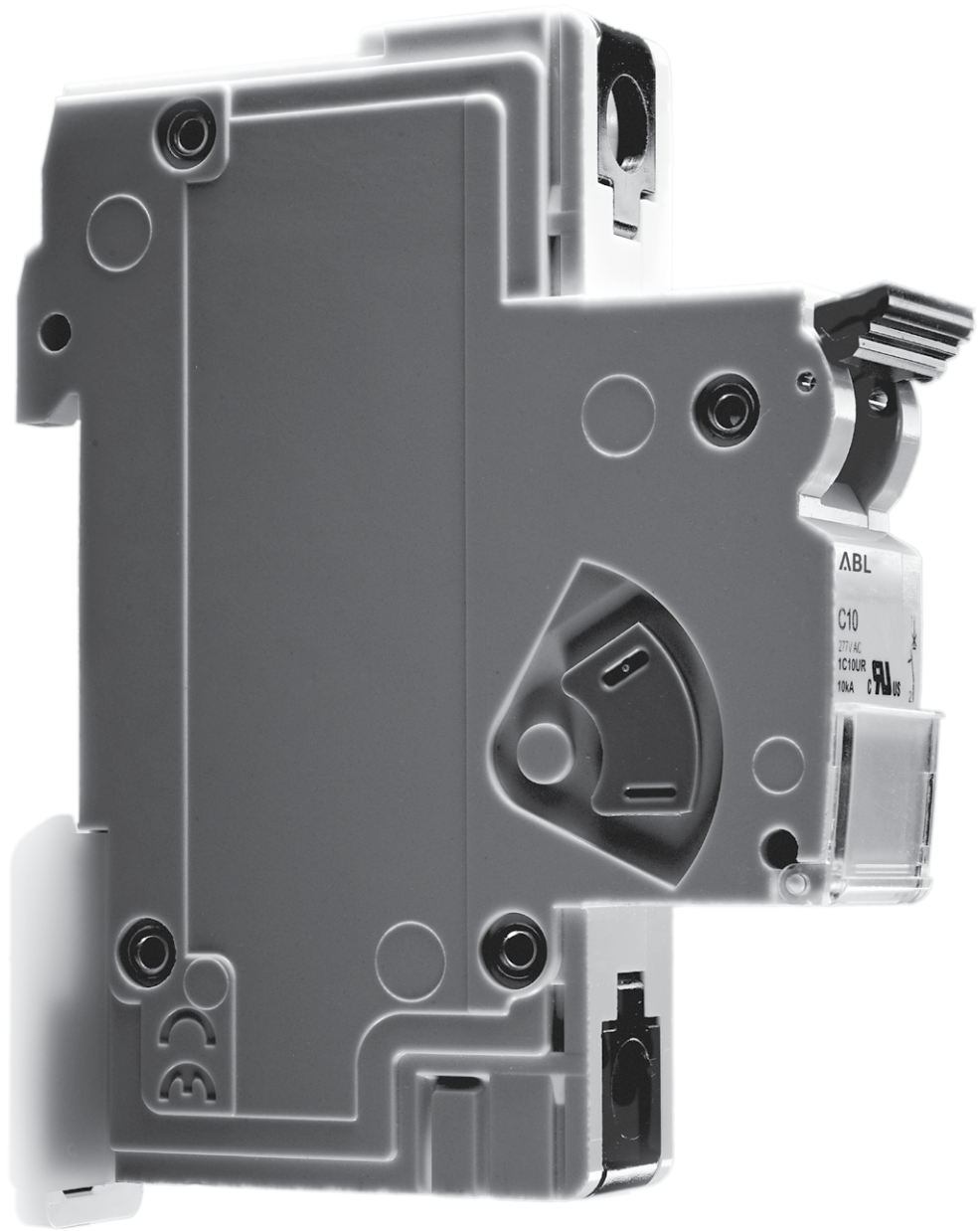

UL 1077

UL 1077 AND CSA-22.2 NO. 235 COMPLIANT SWITCHING DEVICES

Our range of UL 1077 supplementary protectors can be used where additional protection is required in control circuits. Combined with the accessories from our UL 508 UM range it also offers enhanced monitoring and control capabilities.

SWITCHING DEVICES SUPPLEMENTARY PROTECTOR

according to UL 1077 and CSA-22.2 No.235 · UR Product Range, B, C and D Characteristics



RATED CURRENT I_n A	CHARACTERISTIC			WEIGHT G / EACH	PACKING UNIT
	B ITEM NO.	C ITEM NO.	D ITEM NO.		
1-pole					
0.5		1C05UR	1D05UR	150	12
1	1B1UR	1C1UR	1D1UR	150	12
2	1B2UR	1C2UR	1D2UR	150	12
3	1B3UR	1C3UR	1D3UR	150	12
4	1B4UR	1C4UR	1D4UR	150	12
5	1B5UR	1C5UR	1D5UR	150	12
6	1B6UR	1C6UR	1D6UR	150	12
8	1B8UR	1C8UR	1D8UR	150	12
10	1B10UR	1C10UR	1D10UR	150	12
12	1B12UR	1C12UR	1D12UR	150	12
13	1B13UR	1C13UR	1D13UR	150	12
15	1B15UR	1C15UR	1D15UR	150	12
16	1B16UR	1C16UR	1D16UR	150	12
20	1B20UR	1C20UR	1D20UR	150	12
25	1B25UR	1C25UR	1D25UR	150	12
30	1B30UR	1C30UR	1D30UR	150	12
32	1B32UR	1C32UR	1D32UR	150	12
40	1B40UR	1C40UR	1D40UR	150	12
50	1B50UR	1C50UR	1D50UR	150	12
60	1B60UR	1C60UR	1D60UR	150	12
63 *	1B63UR	1C63UR	1D63UR	150	12

* 63 A without UL approval



2-pole					
0.5		2C05UR	2D05UR	300	6
1	2B1UR	2C1UR	2D1UR	300	6
2		2C2UR	2D2UR	300	6
3	2B3UR	2C3UR	2D3UR	300	6
4	2B4UR	2C4UR	2D4UR	300	6
5	2B5UR	2C5UR	2D5UR	300	6
6	2B6UR	2C6UR	2D6UR	300	6
8	2B8UR	2C8UR	2D8UR	300	6
10	2B10UR	2C10UR	2D10UR	300	6
12	2B12UR	2C12UR	2D12UR	300	6
13	2B13UR	2C13UR	2D13UR	300	6
15	2B15UR	2C15UR	2D15UR	300	6
16	2B16UR	2C16UR	2D16UR	300	6
20	2B20UR	2C20UR	2D20UR	300	6
25	2B25UR	2C25UR	2D25UR	300	6
30	2B30UR	2C30UR	2D30UR	300	6
32	2B32UR	2C32UR	2D32UR	300	6
40	2B40UR	2C40UR	2D40UR	300	6
50	2B50UR	2C50UR	2D50UR	300	6
60	2B60UR	2C60UR	2D60UR	300	6
63 *	2B63UR	2C63UR	2D63UR	300	6

* 63 A without UL approval

SWITCHING DEVICES SUPPLEMENTARY PROTECTOR

according to UL 1077 and CSA-22.2 No.235 · UR Product Range, B, C and D Characteristics



RATED CURRENT I_n A	CHARACTERISTIC			WEIGHT G / EACH	PACKING UNIT
	B ITEM NO.	C ITEM NO.	D ITEM NO.		

3-pole					
0.5		3C05UR	3D05UR	450	4
1	3B1UR	3C1UR	3D1UR	450	4
2	3B2UR	3C2UR	3D2UR	450	4
3	3B3UR	3C3UR	3D3UR	450	4
4	3B4UR	3C4UR	3D4UR	450	4
5	3B5UR	3C5UR	3D5UR	450	4
6	3B6UR	3C6UR	3D6UR	450	4
8	3B8UR	3C8UR	3D8UR	450	4
10	3B10UR	3C10UR	3D10UR	450	4
12	3B12UR	3C12UR	3D12UR	450	4
13	3B13UR	3C13UR	3D13UR	450	4
15	3B15UR	3C15UR	3D15UR	450	4
16	3B16UR	3C16UR	3D16UR	450	4
20	3B20UR	3C20UR	3D20UR	450	4
25	3B25UR	3C25UR	3D25UR	450	4
30	3B30UR	3C30UR	3D30UR	450	4
32	3B32UR	3C32UR	3D32UR	450	4
40	3B40UR	3C40UR	3D40UR	450	4
50	3B50UR	3C50UR	3D50UR	450	4
60	3B60UR	3C60UR	3D60UR	450	4
63 *	3B63UR	3C63UR	3D63UR	450	4

* 63 A without UL approval



RATED CURRENT I_n A	RATED VOLTAGE VOLT AC	TEST CURRENTS * ELECTROMAGNETIC		ITEM NO.	WEIGHT G / EACH	PACKING UNIT
		NOT TRIPPING I_1 A	TRIPPING I_2 A			

Neutral switch – for mounting instructions please consult page 75						
0.3 - 63	277/480	400	700	N63UM	150	5

* additional electromagnetic protection



ACCESSORIES FOR SWITCHING DEVICES

Manual Motor Controller and Supplementary Protectors
according to UL 508 and CSA-22.2 No.14 for Product Ranges UM and UR

Mounting Instructions of Accessories

Applies to N...UM and FA...UM:

The accessory devices N...UM and FA...UM can be installed on the right or left. The auxiliary contact H...UM can only be installed on the right.

Mounting:

1. Flick the blue switches of all devices to the "OFF" position
2. Remove the grey cover from the switching device and attachment
3. Insert the drive plate between the switching device and N...UM or FA...UM
4. Insert the connecting pin into the switch (insertion depth approx. 7 mm)
5. Attach switching device to N...UM or FA...UM
6. Tighten the connecting screws (observe the the correct screw length)

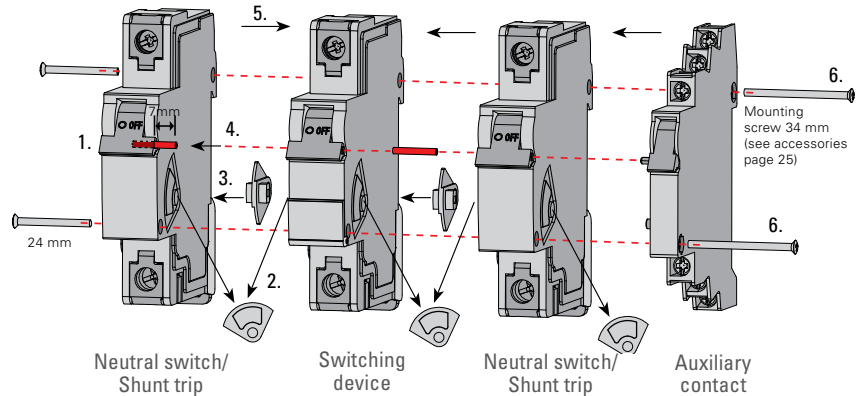

Applies to H...UM:

The auxiliary contact H...UM can only be installed on the right.

Installation:

1. Flick the blue switches of all devices to the "OFF" position
2. Remove the grey cover from the switching device
3. Attach switching device to H...UM
4. Insert the connecting screws and fasten them by a 90° clockwise turn
5. After installation close and open the switch to check operation

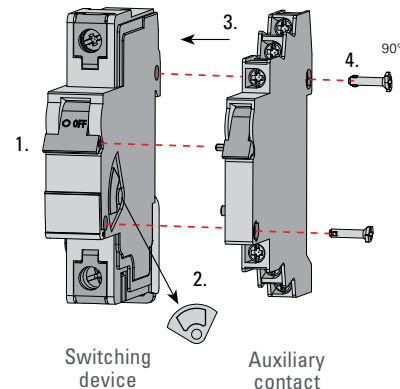

Applies to all switching devices

...UM, ...UR, N63UM and FA...UM

Design of the terminals

- Optical detection of screw position
- Increased breaking resistance if the screwdriver becomes jammed
- Universal connecting terminals, suitable for connecting all known cable lugs such as ring or forked cable lugs and pin terminals
- Ring cable lugs can be connected by opening the flap and removing the connecting screw
- Can also be used for applications that require ring cable lugs (e.g. nuclear power stations)
- DIN EN 50274, VDE 0660-514 compliant protection against contact with live parts is fully guaranteed

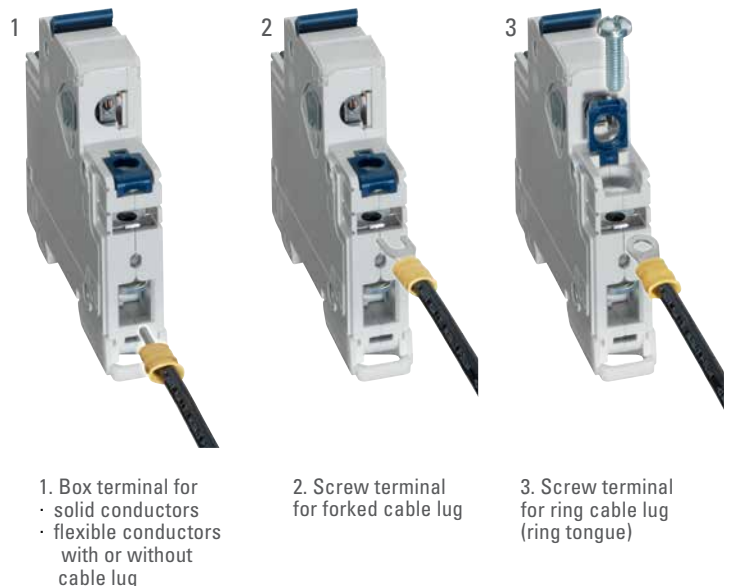

ACCESSORIES FOR SWITCHING DEVICES

Manual Motor Controller and Supplementary Protectors
according to UL 508 and CSA-22.2 No.14 for Product Ranges UM and UR



Auxiliary contact

MODULE	TYPE OF CONTACT	CONTACTS	ITEM NO.	WEIGHT G/EACH	PACKING UNIT
1/2	1 auxiliary contact	1NO	H10UM	35	10
1/2	2 auxiliary contacts	1NO + 1NC	H11UM	40	10
1/2	3 auxiliary contacts	1NO + 2NC	H12UM	45	10
1/2	3 auxiliary contacts	2NO + 1NC	H21UM	45	10

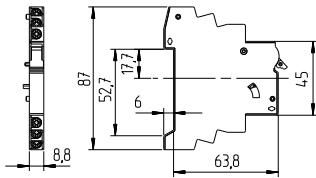

Standards	Acc. to IEC 60947-5-1, DIN EN 60947-5-1, VDE 0660-200, UL 508	
Rated operating currents	10 A / 240 V AC 3 A / 110 V DC 1 A / 220 V DC	
Minimum contact load	1 mA at 24 V DC	
Conductor cross sections		
Type of conductor *)	min.	max.
Single wire	1.0 mm ² (AWG18)	2.5 mm ² (AWG14)
Stranded wire	1.0 mm ² (AWG18)	1.5 mm ² (AWG16)
Stranded wire with ferrule	1.0 mm ² (AWG18)	1.5 mm ² (AWG16)
Torque	max. 0.8 Nm (7 lb.in)	

*) Stripped length 8 - 9 mm

Shunt trip

MODULE	RATED OPERATING VOLTAGE	MAX. OPERATING CURRENT AT UN (T < 10 MS)	ITEM NO.	WEIGHT G/EACH	PACKING UNIT
1	12 V UC	1.3 A	FA12UM	105	5
1	24 V UC	0.6 A	FA24UM	105	5
1	48 - 74 V UC	0.2 A	FA48UM	105	5
1	110 - 240 V UC, 415 V AC	0.25 A at 110 V 0.5 A at 240 V 0.58 A at 277 V	FA110UM	105	5

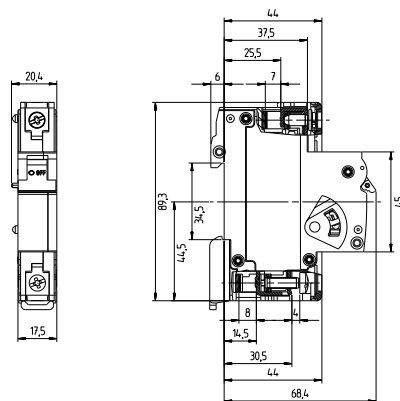

DIMENSION DRAWING FA..UM, N63UM



Activation lock

ITEM NO.	WEIGHT G/EACH	PACKING UNIT
----------	---------------	--------------

EASS	2	10
-------------	---	----

SWITCHING DEVICES SUPPLEMENTARY PROTECTOR

according to UL 1077 and CSA-22.2 No.235 · Product Range UR, B, C and D Characteristics · Technical Data

Characteristic		B	C	D
Application		Lighting Control circuits General electronics Wiring protection Business equipment Appliances	Lighting Control circuits Wiring protection Business equipment Appliances	Control transformers Power supplies Reactive loads
Number of poles		1 - 3; 1 + N; 3 + N		
Standards		UL 1077 and CSA-22.2 No.235		
Interrupting capacity		see data sheet for use in the USA and Canada (page 75)		
Current limiting class		3	3	
Max. back-up fuse		see data sheet for use in the USA and Canada (page 75)		
Rated voltage AC		277 / 480 V		
Rated current range		1 - 63* A	0.5 - 63* A	0.5 - 63* A
Test currents	Thermal not tripping $I_1 (A) > 1 \text{ h}$	$1.13 \times I_N$	$1.13 \times I_N$	$1.13 \times I_N$
	Thermal tripping $I_2 (A) < 1 \text{ h}$	$1.45 \times I_N$	$1.45 \times I_N$	$1.45 \times I_N$
	Electromagnetic not tripping $I_4 (A) > 0,1 \text{ s}$	$3 \times I_N$	$5 \times I_N$	$10 \times I_N$
	Electromagnetic tripping $I_5 (A) < 0,1 \text{ s}$	$5 \times I_N$	$10 \times I_N$	$16 \times I_N$
Reference calibration temperature of the thermal tripping threshold		30° C + 5° C Influence of the ambient temperature on the thermal release threshold: Decrease of the current values with higher ambient temperature and increase with lower temperatures of approximately 5% per 10°C difference in temperature		
Frequency range of the electromagnetic trip		16 ² / ₃ to 60 Hz		
Ambient temperature		-25 °C to +55 °C		
Storage temperature		-40 °C to +70 °C		
Device depth according to DIN 43880		68 mm		
Mechanical life		10,000 cycles (ON / OFF)		
Protection cover		Finger safe and safe to back of hand according to DIN EN 50274/VDE0660-514		
Insulation group acc. to DIN/VDE 0110		C at 250 V AC B at 400 V AC		
Degree of protection acc. to EN/IEC 60529		IP20		
Installation position		any		
Mounting		DIN-rail according to DIN EN 60715 35 mm		
Lockability		The handle can be secured against manual switching in the on and off position by a lead seal		
Climatic resistance		Humid heat constant according to DIN EN 60068-2-78 Humid heat cycle according to DIN EN 60068-2-30		
Vibration resistance		> 15 g according to DIN EN 60068-2-59 during a load with I_1		
Resistance to mechanical shocks		25g 11ms		

* 63 A without UL approval



SWITCHING DEVICES SUPPLEMENTARY PROTECTOR

according to UL 1077 and CSA-22.2 No.235 · Product Range UR, B, C and D Characteristics · Technical Data

Type of conductor *)	Conductor cross sections			
	Box terminal bottom		Box terminal top	
	max.	min.	max.	min.
Single wire	35 mm ² (AWG2)	1 mm ² (AWG18)	25 mm ² (AWG3)	1 mm ² (AWG18)
Multiple wire	35 mm ² (AWG2)	16 mm ² (AWG6)	25 mm ² (AWG3)	16 mm ² (AWG6)
Stranded wire	25 mm ² (AWG3)	1 mm ² (AWG18)	16 mm ² (AWG6)	1 mm ² (AWG18)
Stranded wire with ferrule	16 mm ² (AWG6)	1 mm ² (AWG18)	16 mm ² (AWG6)	1 mm ² (AWG18)
Busbar cable lug	up to 3 mm thickness		up to 1.5 mm thickness	
Torque	max. 2.3 Nm (20 lb.in)			

*) Stripped length: bottom 12 - 14 mm, top 10 - 12 mm

Interrupting capacity and maximum back-up fuse for use in the USA and Canada					
Characteristic	B, C and D				
	UL 1077 and CSA-22.2 No.235				
Standards	Number of poles	Maximum rated voltage [V]	Rated current [A]	Interrupting capacity [kA]	Maximum back-up fuse [A]
Interrupting capacity at rated voltage Ambient temperature 40 °C	1 / 1 + N	277	0.3 - 10	10	70 A
	1 / 1 + N	277	12 - 60	10	4 x I _n
	2 / 3 / 3 + N	480	0.3 - 10	10	70 A
	2 / 3 / 3 + N	480	12 - 60	10	4 x I _n

Internal resistance for Product Ranges UR			
Rated current [A]	Trip characteristic		
	B [Ohm]	C [Ohm]	D [Ohm]
0.5		6.8540	6.0009
1,0	1.7000	1.7000	1.7560
2,0	0.4190	0.4190	0.4190
3,0	0.2020	0.2020	0.2020
4,0	0.1090	0.1090	0.1090
5,0	0.0654	0.0654	0.0654
6,0	0.0528	0.0528	0.0491
8,0	0.0278	0.0278	0.0240
10	0.0216	0.0216	0.0187
12/13	0.0113	0.0084	0.0085
15/16	0.0085	0.0085	0.0076
20	0.0067	0.0067	0.0064
25	0.0050	0.0050	0.0041
30/32	0.0032	0.0032	0.0027
40	0.0025	0.0025	0.0022
50	0.0019	0.0019	0.0018
60/63 *	0.0018	0.0018	0.0017

* 63 A without UL approval

SWITCHING DEVICES SUPPLEMENTARY PROTECTOR

according to UL 1077 and CSA-22.2 No.235 · Product Range UR, B, C and D Characteristics · Technical Data

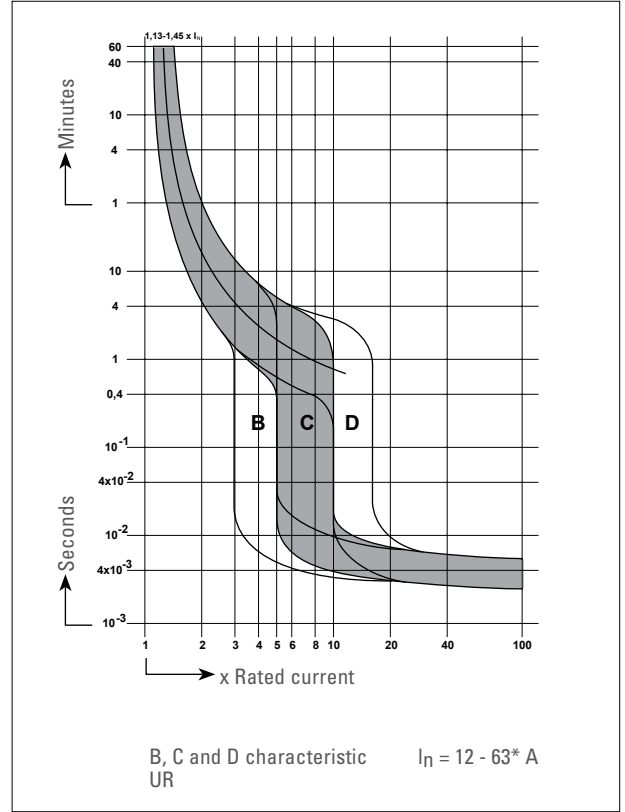
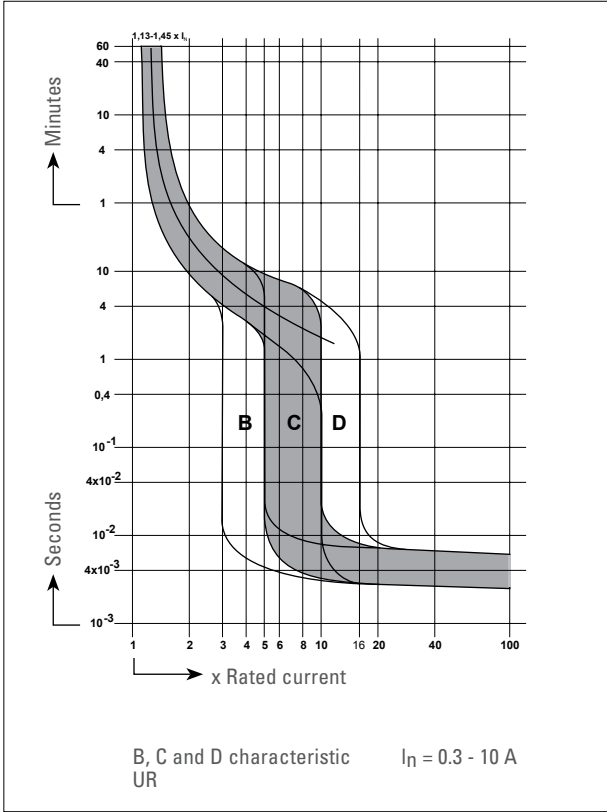

* 63 A without UL approval

Dimension Drawing

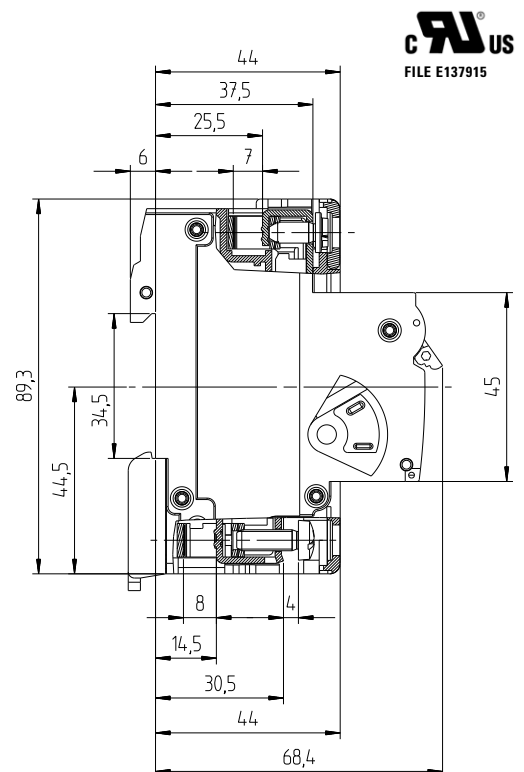
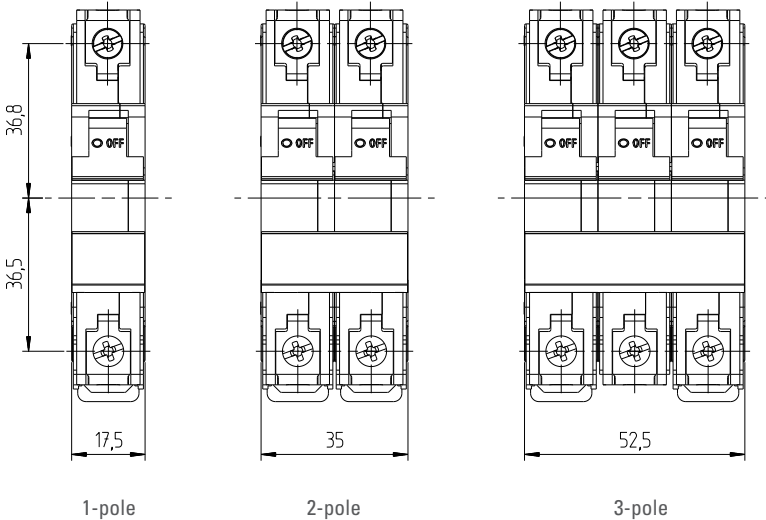

ITEM NUMBER DIRECTORY

ITEM NO.	PAGE
1B1.6UM	35
1B10UM	35
1B10UR	72
1B12UR	72
1B13UM	35
1B13UR	72
1B15UM	35
1B15UR	72
1B16UM	35
1B16UR	72
1B1UM	35
1B1UR	72
1B2.5UM	35
1B20UM	35
1B20UR	72
1B25UM	35
1B25UR	72
1B2UM	35
1B2UR	72
1B3.5UM	35
1B30UM	35
1B30UR	72
1B32UM	35
1B32UR	72
1B3UM	35
1B3UR	72
1B40UM	35
1B40UR	72
1B4UM	35
1B4UR	72
1B50UM	35
1B50UR	72
1B5UM	35
1B5UR	72
1B60UM	35
1B60UR	72
1B63UM	35
1B63UR	72
1B6UM	35
1B6UR	72
1B8UR	72
1C03DL	22
1C03UL	20
1C03UM	35
1C05DL	22
1C05UL	20
1C05UM	35
1C05UR	72
1C075UM	35
1C1.6DL	22
1C1.6UL	20
1C1.6UM	35
1C10DL	22
1C10UL	20

ITEM NO.	PAGE
1C10UM	35
1C10UR	72
1C12DL	22
1C12UL	20
1C12UR	72
1C13DL	22
1C13UL	20
1C13UM	35
1C13UR	72
1C15DL	22
1C15UL	20
1C15UM	35
1C15UR	72
1C16DL	22
1C16UL	20
1C16UM	35
1C16UR	72
1C1DL	22
1C1UL	20
1C1UM	35
1C1UR	72
1C2.5UM	35
1C20DL	22
1C20UL	20
1C20UM	35
1C20UR	72
1C25DL	22
1C25UL	20
1C25UM	35
1C25UR	72
1C2DL	22
1C2UL	20
1C2UM	35
1C2UR	72
1C3.5UM	35
1C30DL	22
1C30UL	20
1C30UM	35
1C30UR	72
1C32DL	22
1C32UL	20
1C32UM	35
1C32UR	72
1C3DL	22
1C3UL	20
1C3UM	35
1C3UR	72
1C40DL	22
1C40UL	20
1C40UM	35
1C40UR	72
1C4DL	22
1C4UL	20
1C4UM	35

ITEM NO.	PAGE
1C4UR	72
1C50DL	22
1C50UL	20
1C50UM	35
1C50UR	72
1C5DL	22
1C5UL	20
1C5UM	35
1C5UR	72
1C60DL	22
1C60UL	20
1C60UM	35
1C60UR	72
1C63DL	22
1C63UL	20
1C63UM	35
1C63UR	72
1C6DL	22
1C6UL	20
1C6UM	35
1C6UR	72
1C8DL	22
1C8UL	20
1C8UM	35
1C8UR	72
1D03UL	20
1D03UM	35
1D05UL	20
1D05UM	35
1D05UR	72
1D075UM	35
1D1.6UL	20
1D1.6UM	35
1D10UL	20
1D10UM	35
1D10UR	72
1D12UL	20
1D12UR	72
1D13UL	20
1D13UM	35
1D13UR	72
1D15UL	20
1D15UM	35
1D15UR	72
1D16UL	20
1D16UM	35
1D16UR	72
1D1UL	20
1D1UM	35
1D1UR	72
1D2.5UM	35
1D20UL	20
1D20UM	35
1D20UR	72

ITEM NO.	PAGE
1D25UL	20
1D25UM	35
1D25UR	72
1D2UL	20
1D2UM	35
1D2UR	72
1D3.5UM	35
1D30UL	20
1D30UM	35
1D30UR	72
1D32UL	20
1D32UM	35
1D32UR	72
1D3UL	20
1D3UM	35
1D3UR	72
1D40UL	20
1D40UM	35
1D40UR	72
1D4UL	20
1D4UM	35
1D4UR	72
1D50UL	20
1D50UM	35
1D50UR	72
1D5UL	20
1D5UM	35
1D5UR	72
1D60UL	20
1D60UM	35
1D60UR	72
1D63UL	20
1D63UM	35
1D63UR	72
1D6UL	20
1D6UM	35
1D6UR	72
1D8UL	20
1D8UM	35
1D8UR	72
1E03UM	35
1E05UM	35
1E075UM	35
1E1.6UM	35
1E10UM	35
1E13UM	35
1E15UM	35
1E16UM	35
1E1UM	35
1E2.5UM	35
1E20UM	35
1E25UM	35
1E2UM	35
1E3.5UM	35

ITEM NUMBER DIRECTORY

ITEM NO.	PAGE
1E30UM	35
1E32UM	35
1E3UM	35
1E40UM	35
1E4UM	35
1E50UM	35
1E5UM	35
1E60UM	35
1E63UM	35
1E6UM	35
1E8UM	35
1G03UM	35
1G05UM	35
1G08UM	35
1G1.6UM	35
1G10UM	35
1G12UM	35
1G13UM	35
1G15UM	35
1G16UM	35
1G1UM	35
1G2.5UM	35
1G20UM	35
1G25UM	35
1G2UM	35
1G3.5UM	35
1G30UM	35
1G32UM	35
1G3UM	35
1G40UM	35
1G4UM	35
1G50UM	35
1G5UM	35
1G60UM	35
1G63UM	35
1G6UM	35
1G8UM	35
1Z03UM	35
1Z05UM	35
1Z075UM	35
1Z1.6UM	35
1Z10UM	35
1Z12UM	35
1Z13UM	35
1Z15UM	35
1Z16UM	35
1Z1UM	35
1Z2.5UM	35
1Z20UM	35
1Z25UM	35
1Z2UM	35
1Z3.5UM	35
1Z30UM	35
1Z32UM	35

ITEM NO.	PAGE
1Z3UM	35
1Z40UM	35
1Z4UM	35
1Z50UM	35
1Z5UM	35
1Z6UM	35
1Z8UM	35
2B10UM	36
2B10UR	72
2B12UR	72
2B13UM	36
2B13UR	72
2B15UM	36
2B15UR	72
2B16UM	36
2B16UR	72
2B1UM	36
2B1UR	72
2B20UM	36
2B20UR	72
2B25UM	36
2B25UR	72
2B30UM	36
2B30UR	72
2B32UM	36
2B32UR	72
2B3UM	36
2B3UR	72
2B40UM	36
2B40UR	72
2B4UM	36
2B4UR	72
2B50UM	36
2B50UR	72
2B5UM	36
2B5UR	72
2B60UM	36
2B60UR	72
2B63UM	36
2B63UR	72
2B6UM	36
2B6UR	72
2B8UR	72
2C03DL	22
2C03UL	20
2C03UM	36
2C05DL	22
2C05UL	20
2C05UM	36
2C05UR	72
2C075UM	36
2C1.6DL	22
2C1.6UL	20
2C1.6UM	36

ITEM NO.	PAGE
2C10DL	22
2C10UL	20
2C10UM	36
2C10UR	72
2C12DL	22
2C12UL	20
2C12UR	72
2C13DL	22
2C13UL	20
2C13UM	36
2C13UR	72
2C15DL	22
2C15UL	20
2C15UM	36
2C15UR	72
2C16DL	22
2C16UL	20
2C16UM	36
2C16UR	72
2C1DL	22
2C1UL	20
2C1UM	36
2C1UR	72
2C2.5UM	36
2C20DL	22
2C20UL	20
2C20UM	36
2C20UR	72
2C25DL	22
2C25UL	20
2C25UM	36
2C25UR	72
2C2DL	22
2C2UL	20
2C2UM	36
2C2UR	72
2C3.5UM	36
2C30DL	22
2C30UL	20
2C30UM	36
2C30UR	72
2C32DL	22
2C32UL	20
2C32UM	36
2C32UR	72
2C3DL	22
2C3UL	20
2C3UM	36
2C3UR	72
2C40DL	22
2C40UL	20
2C40UM	36
2C40UR	72
2C4DL	22

ITEM NO.	PAGE
2C4UL	20
2C4UM	36
2C4UR	72
2C50DL	22
2C50UL	20
2C50UM	36
2C50UR	72
2C5DL	22
2C5UL	20
2C5UM	36
2C5UR	72
2C60DL	22
2C60UL	20
2C60UM	36
2C60UR	72
2C63DL	22
2C63UL	20
2C63UM	36
2C63UR	72
2C6DL	22
2C6UL	20
2C6UM	36
2C6UR	72
2C8DL	22
2C8UL	20
2C8UM	36
2C8UR	72
2D03UL	20
2D03UM	36
2D05UL	20
2D05UM	36
2D05UR	72
2D075UM	36
2D1.6UL	20
2D1.6UM	36
2D10UL	20
2D10UM	36
2D10UR	72
2D12UL	20
2D12UR	72
2D13UL	20
2D13UM	36
2D13UR	72
2D15UL	20
2D15UM	36
2D15UR	72
2D16UL	20
2D16UM	36
2D16UR	72
2D1UL	20
2D1UM	36
2D1UR	72
2D2.5UM	36
2D20UL	20

ITEM NUMBER DIRECTORY

ITEM NO.	PAGE
2D20UM	36
2D20UR	72
2D25UL	20
2D25UM	36
2D25UR	72
2D2UL	20
2D2UM	36
2D2UR	72
2D3.5UM	36
2D30UL	20
2D30UM	36
2D30UR	72
2D32UL	20
2D32UM	36
2D32UR	72
2D3UL	20
2D3UM	36
2D3UR	72
2D40UL	20
2D40UM	36
2D40UR	72
2D4UL	20
2D4UM	36
2D4UR	72
2D50UL	20
2D50UM	36
2D50UR	72
2D5UL	20
2D5UM	36
2D5UR	72
2D60UL	20
2D60UM	36
2D60UR	72
2D63UL	20
2D63UM	36
2D63UR	72
2D6UL	20
2D6UM	36
2D6UR	72
2D8UL	20
2D8UM	36
2D8UR	72
2E03UM	36
2E05UM	36
2E075UM	36
2E1.6UM	36
2E10UM	36
2E13UM	36
2E15UM	36
2E16UM	36
2E1UM	36
2E2.5UM	36
2E20UM	36
2E25UM	36

ITEM NO.	PAGE
2E2UM	36
2E3.5UM	36
2E30UM	36
2E32UM	36
2E3UM	36
2E40UM	36
2E4UM	36
2E50UM	36
2E5UM	36
2E60UM	36
2E63UM	36
2E6UM	36
2E8UM	36
2G03UM	36
2G05UM	36
2G08UM	36
2G1.6UM	36
2G10UM	36
2G12UM	36
2G13UM	36
2G15UM	36
2G16UM	36
2G1UM	36
2G2.5UM	36
2G20UM	36
2G25UM	36
2G2UM	36
2G3.5UM	36
2G30UM	36
2G32UM	36
2G3UM	36
2G40UM	36
2G4UM	36
2G50UM	36
2G5UM	36
2G60UM	36
2G63UM	36
2G6UM	36
2G8UM	36
2Z03UM	36
2Z05UM	36
2Z075UM	36
2Z1.6UM	36
2Z10UM	36
2Z12UM	36
2Z13UM	36
2Z15UM	36
2Z16UM	36
2Z1UM	36
2Z2.5UM	36
2Z20UM	36
2Z25UM	36
2Z2UM	36
2Z3.5UM	36

ITEM NO.	PAGE
2Z30UM	36
2Z32UM	36
2Z3UM	36
2Z40UM	36
2Z4UM	36
2Z50UM	36
2Z5UM	36
2Z6UM	36
2Z8UM	36
3B1.6UM	37
3B10UM	37
3B10UR	73
3B12UR	73
3B13UM	37
3B13UR	73
3B15UM	37
3B15UR	73
3B16UM	37
3B16UR	73
3B1UM	37
3B1UR	73
3B2.5UM	37
3B20UM	37
3B20UR	73
3B25UM	37
3B25UR	73
3B2UM	37
3B2UR	73
3B3.5UM	37
3B30UM	37
3B30UR	73
3B32UM	37
3B32UR	73
3B3UM	37
3B3UR	73
3B40UM	37
3B40UR	73
3B4UM	37
3B4UR	73
3B50UM	37
3B50UR	73
3B5UM	37
3B5UR	73
3B60UM	37
3B60UR	73
3B63UM	37
3B63UR	73
3B6UM	37
3B6UR	73
3B8UR	73
3C03UL	21
3C03UM	37
3C05UL	21
3C05UM	37

ITEM NO.	PAGE
3C05UR	73
3C075UM	37
3C1.6UL	21
3C1.6UM	37
3C10UL	21
3C10UM	37
3C10UR	73
3C12UL	21
3C12UR	73
3C13UL	21
3C13UM	37
3C13UR	73
3C15UL	21
3C15UM	37
3C15UR	73
3C16UL	21
3C16UM	37
3C16UR	73
3C1UL	21
3C1UM	37
3C1UR	73
3C2.5UM	37
3C20UL	21
3C20UM	37
3C20UR	73
3C25UL	21
3C25UM	37
3C25UR	73
3C2UL	21
3C2UM	37
3C2UR	73
3C3.5UM	37
3C30UL	21
3C30UM	37
3C30UR	73
3C32UL	21
3C32UM	37
3C32UR	73
3C3UL	21
3C3UM	37
3C3UR	73
3C40UL	21
3C40UM	37
3C40UR	73
3C4UL	21
3C4UM	37
3C4UR	73
3C50UL	21
3C50UM	37
3C50UR	73
3C5UL	21
3C5UM	37
3C5UR	73
3C60UL	21

ITEM NUMBER DIRECTORY

ITEM NO.	PAGE
3C60UM	37
3C60UR	73
3C63UL	21
3C63UM	37
3C63UR	73
3C6UL	21
3C6UM	37
3C6UR	73
3C8UL	21
3C8UM	37
3C8UR	73
3D03UL	21
3D03UM	37
3D05UL	21
3D05UM	37
3D05UR	73
3D075UM	37
3D1.6UL	21
3D1.6UM	37
3D10UL	21
3D10UM	37
3D10UR	73
3D12UL	21
3D12UR	73
3D13UL	21
3D13UM	37
3D13UR	73
3D15UL	21
3D15UM	37
3D15UR	73
3D16UL	21
3D16UM	37
3D16UR	73
3D1UL	21
3D1UM	37
3D1UR	73
3D2.5UM	37
3D20UL	21
3D20UM	37
3D20UR	73
3D25UL	21
3D25UM	37
3D25UR	73
3D2UL	21
3D2UM	37
3D2UR	73
3D3.5UM	37
3D30UL	21
3D30UM	37
3D30UR	73
3D32UL	21
3D32UM	37
3D32UR	73
3D3UL	21

ITEM NO.	PAGE
3D3UM	37
3D3UR	73
3D40UL	21
3D40UM	37
3D40UR	73
3D4UL	21
3D4UM	37
3D4UR	73
3D50UL	21
3D50UM	37
3D50UR	73
3D5UL	21
3D5UM	37
3D5UR	73
3D60UL	21
3D60UM	37
3D60UR	73
3D63UL	21
3D63UM	37
3D63UR	73
3D6UL	21
3D6UM	37
3D6UR	73
3D8UL	21
3D8UM	37
3D8UR	73
3E03UM	37
3E05UM	37
3E075UM	37
3E1.6UM	37
3E10UM	37
3E13UM	37
3E15UM	37
3E16UM	37
3E1UM	37
3E2.5UM	37
3E20UM	37
3E25UM	37
3E2UM	37
3E3.5UM	37
3E30UM	37
3E32UM	37
3E3UM	37
3E40UM	37
3E4UM	37
3E50UM	37
3E5UM	37
3E60UM	37
3E63UM	37
3E6UM	37
3E8UM	37
3G03UM	37
3G05UM	37
3G08UM	37

ITEM NO.	PAGE
3G1.6UM	37
3G10UM	37
3G12UM	37
3G13UM	37
3G15UM	37
3G16UM	37
3G1UM	37
3G2.5UM	37
3G20UM	37
3G25UM	37
3G2UM	37
3G3.5UM	37
3G30UM	37
3G32UM	37
3G3UM	37
3G40UM	37
3G4UM	37
3G50UM	37
3G5UM	37
3G60UM	37
3G63UM	37
3G6UM	37
3G8UM	37
3Z03UM	37
3Z05UM	37
3Z075UM	37
3Z1.6UM	37
3Z10UM	37
3Z12UM	37
3Z13UM	37
3Z15UM	37
3Z16UM	37
3Z1UM	37
3Z2.5UM	37
3Z20UM	37
3Z25UM	37
3Z2UM	37
3Z3.5UM	37
3Z30UM	37
3Z32UM	37
3Z3UM	37
3Z40UM	37
3Z4UM	37
3Z50UM	37
3Z5UM	37
3Z6UM	37
3Z8UM	37
AK.U1	40
AK35U	25
AMS110	63
AMS220	63
AMS24	63
AMS380	63
AMS500	63

ITEM NO.	PAGE
AMSD24	63
BS.UL	25
E983419	25
EASS	24
EASS	39
EASS	55
EASS	75
FA110UL	24
FA110UM	39
FA110UM	75
FA110UM	54
FA12UL	24
FA12UM	39
FA12UM	75
FA12UM	54
FA24UL	24
FA24UM	39
FA24UM	75
FA24UM	54
FA48UL	24
FA48UM	39
FA48UM	54
FA48UM	75
H10UL	24
H10UM	39
H10UM	54
H10UM	75
H11UL	24
H11UM	39
H11UM	54
H11UM	75
H12UL	24
H12UM	39
H12UM	75
H12UM	54
H21UL	24
H21UM	39
H21UM	75
H21UM	54
HDS	55
HMS01	62
HMS02	62
HMS10	62
HMS11	62
HMS20	62
MA016UM	53
MA025UM	53
MA040UM	53
MA063UM	53
MA1.0UM	53
MA1.6UM	53
MA10UM	53
MA16UM	53
MA2.5UM	53

ITEM NUMBER DIRECTORY

ITEM NO.	PAGE
----------	------

MA20UM	53
MA25UM	53
MA32UM	53
MA4.0UM	53
MA40UM	53
MA6.3UM	53
MS.F55	64
MS.G55	64
MS.PS2	64
MS.PT	64
MS.PV	64
MS.SLG2	64
MS.SLG3	64
MS.SLJ2	64
MS.SLJ3	64
MS.SLR2	64
MS.SLR3	64
MS.SLW2	64
MS.SLW3	64
MS.VS	64
MS016	61
MS025	61
MS040	61
MS063	61
MS1	61
MS1.6	61
MS10	61
MS16	61
MS2.5	61
MS20	61
MS25	61
MS4	61
MS6.3	61
N32UL	21
N63UL	21
N63UM	37
N63UM	73
S106U	25
S106UH	25
S108UH	25
S109U	25
S112U	25
S206U	25
S208UH	25
S210U	25
S210UH	25
S212U	25
S306U	25
S306UH	25
S309U	25
S309UH	25
S312U	25
S3BRU	25
SB.D02	65

ITEM NO.	PAGE
----------	------

SB.D03	65
SB.D04	65
SB.D12	65
SB.D13	65
SB.D14	65
SB.D15	65
SB.D22	65
SB.D24	65
SB.DA1	65
SB.DE1	65
SB.U1	40
SB.U1H	40
SB.U3	40
SB.U3H	40
SB.U9	40
SB16010	41
SB26010	41
SB26216	41
SB31210	41
SB36010	41
SB36016	41
SB36316	41
SB46016	41
SB718U	41
SDO.124	41
SDO.316	41
UMS110	63
UMS220	63
UMS24	63
UMS380	63
UMS500	63
VHMS11	62
VHMS20	62



ABL SURSUM
Bayerische Elektrozubehör GmbH & Co. KG

Albert-Büttner-Straße 11
D-91207 Lauf / Pegnitz

Tel. +49 (0) 9123 188-0
Fax +49 (0) 9123 188-188

info@abl.de
www.abl.de