



1-Slot and 2-Slot I/O Chassis with Integral Power Supply and Adapter (Cat. No. 1771-AM1 and -AM2)

Installation Instructions

To the Installer

This document provides information on how to install the 1-slot or 2-slot I/O chassis with integral power supply and adapter. It provides information on how to:

- install the chassis
- connect the input power
- install the I/O module
- make switch settings for programmable controller applications
- use the indicators for troubleshooting the power supply and adapter sections.

Installing the Chassis

To install the chassis, proceed as follows:

1. Select an appropriate mounting location, then mount the unit (using the four mounting slots provided on the mounting base) as shown in Figure 1. Complete mounting dimensions are shown in

Figure 1
Mounting Dimensions and Footprint

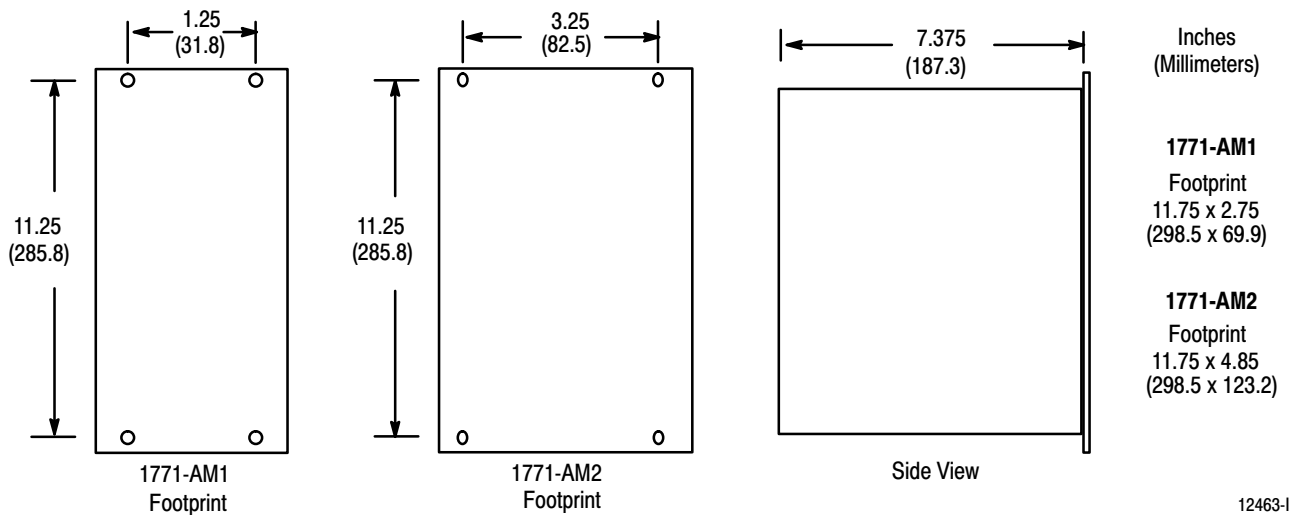
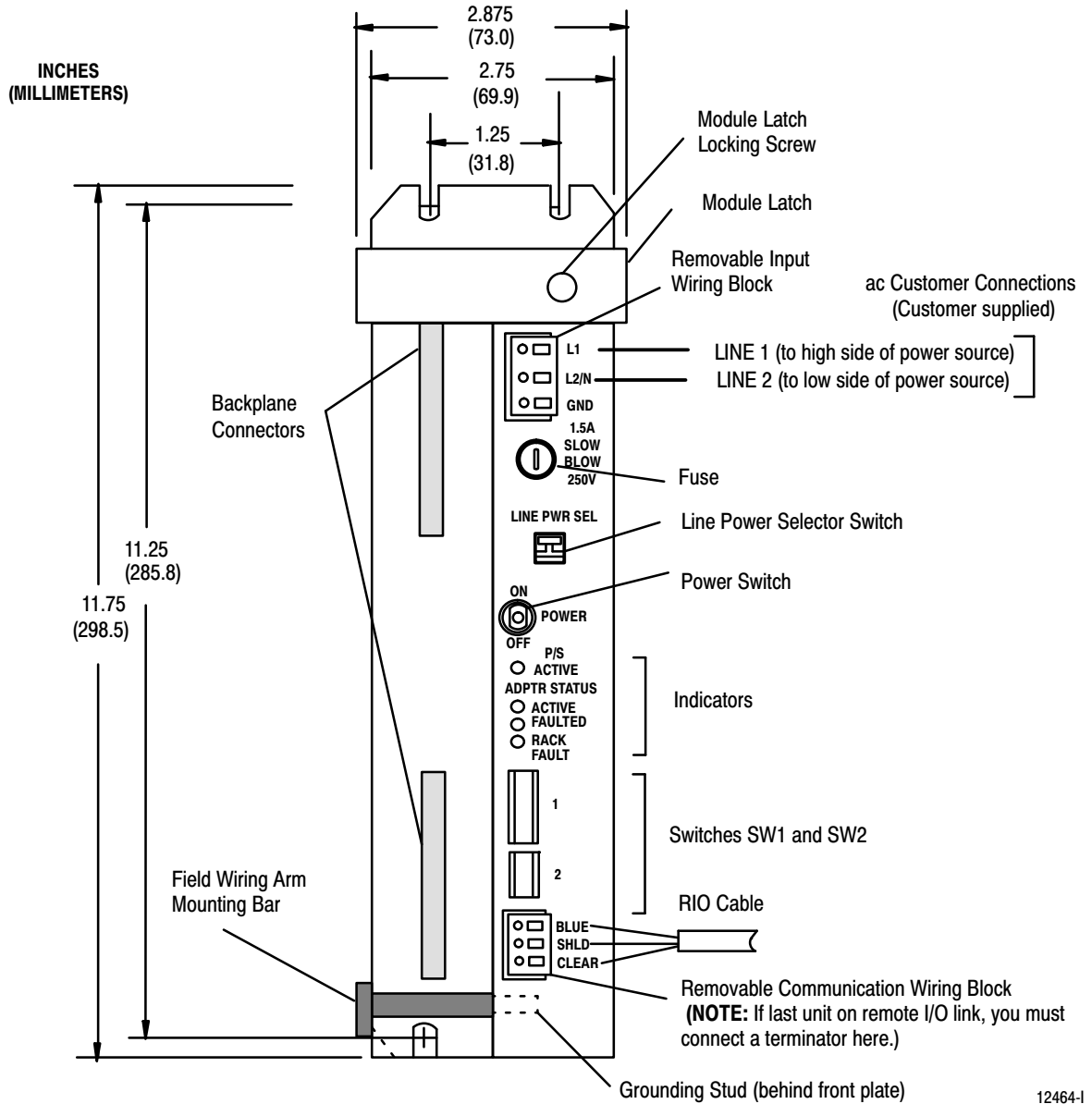

Figure 2

Installation Instructions
1-Slot and 2-Slot I/O Chassis with
Integral Power Supply and Adapter

Figure 2
External Connections and Dimensions for the 1771-AM1



12464-I

Figure 3
External Connections and Dimensions for the 1771-AM2

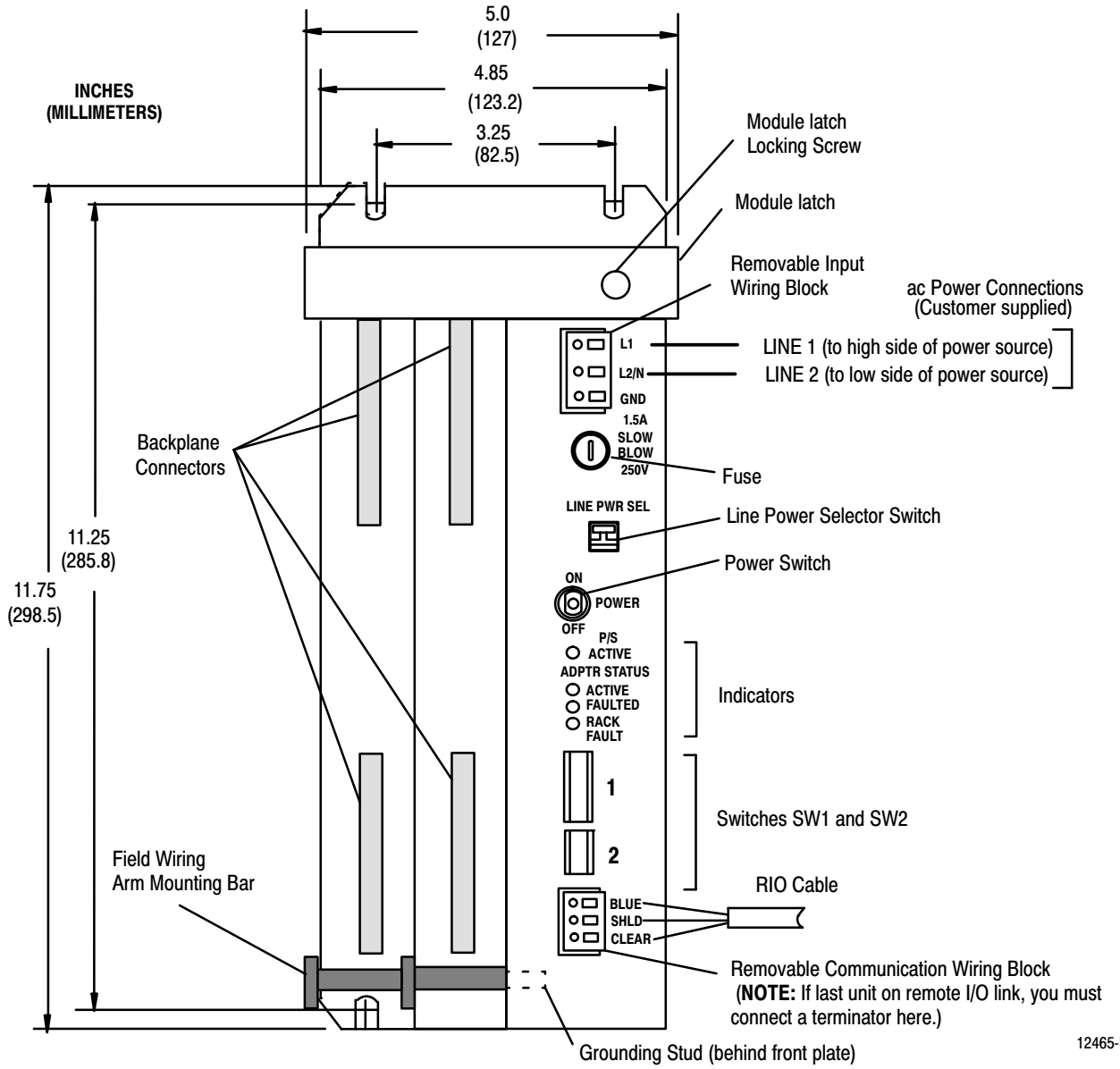

12465-1

Installation Instructions

1-Slot and 2-Slot I/O Chassis with Integral Power Supply and Adapter

2. Ground the chassis as outlined in publication 1770-4.1, Programmable Controller Wiring and Grounding Guidelines. The grounding stud is located on the extension of the field wiring arm mounting bar (). Grounding lug installation is shown in Figure 4.

Figure 4
Grounding Stud Installation

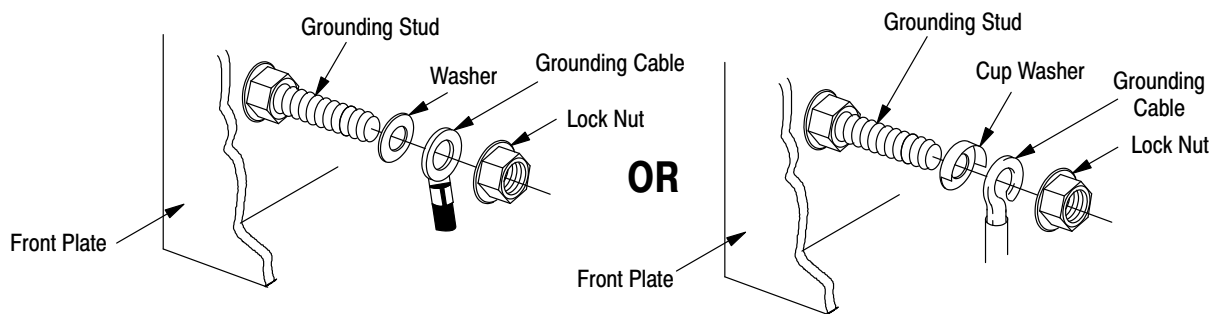

17606

3. Install the keying bands (supplied with the unit) in the backplane connectors (or) to accept the specific type of module(s) you are installing. Keying band information is in the publication accompanying the module.
4. Snap the field wiring arm(s) on the bar at the lower front of the chassis. The field wiring arms are specific to the I/O modules, and are supplied with the modules.
5. Connect the field wiring to the field wiring arms as indicated in the publications accompanying the particular I/O modules you are using.
6. Position line power switch for the proper supply voltage (either 115V or 230V).

Connecting Input Power and Communication Wiring

You can connect these wires while the wiring block is plugged into the 1771-AM, or you can remove the wiring block and lay it on a flat surface to connect these wires. To remove the wiring block, pull it straight out from the receptacle on the module. Each of the terminals accepts a single 14-AWG wire (max). Strip 0.35 inches of insulation off the wire.

Figure 1

Figure 2 Figure 3

Input Wiring Connections

Figure 5 shows details of how to connect a wire to a terminal on the removable input wiring block. Use a wedge-tipped tool (such as a small screw driver) to spring the clip open to insert the wire. If the wiring block is plugged into the 1771-AM, insert the tool parallel to the wire (push straight in). If the wiring block is laying on a flat surface, insert the tool perpendicular to the wire (push straight down).

1. Connect the high side of the power source to the L1 terminal of the power supply.
2. Connect the low side of the power source to the L2 or N (neutral) terminal of the power supply.
3. Connect the GND (ground) terminal of the power supply to the central ground bus in the enclosure.
4. After making the wiring connections, reinsert the wiring block into the front plate. Be sure that the plug is completely inserted, and the locking prongs are engaged.

Figure 5
Connecting Power Wiring to the Removable Input Wiring Block

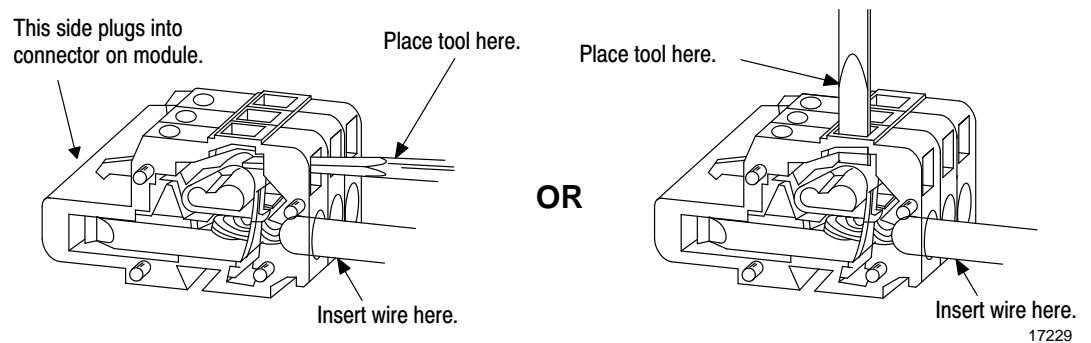

Communication Wiring Connections

The communication wiring block connector is similar to the input wiring block, but uses a clamping block to hold the wires. Loosen the screw and insert the stripped end of the wire into the slot in the front of the block. Then tighten the screw to clamp the wire.

Connect the communication connections as follows (refer to):)

Connector Identification	Remote I/O	Data Highway
BLUE	Blue Wire	Clear Wire
SHLD	Shield	Shield
CLEAR	Clear Wire	Blue Wire

Figure 6

Important: If this is the last unit on the remote I/O link, you must install a terminating resistor across the top and bottom (blue and clear) terminals.

Figure 6
Connecting the Communication Link

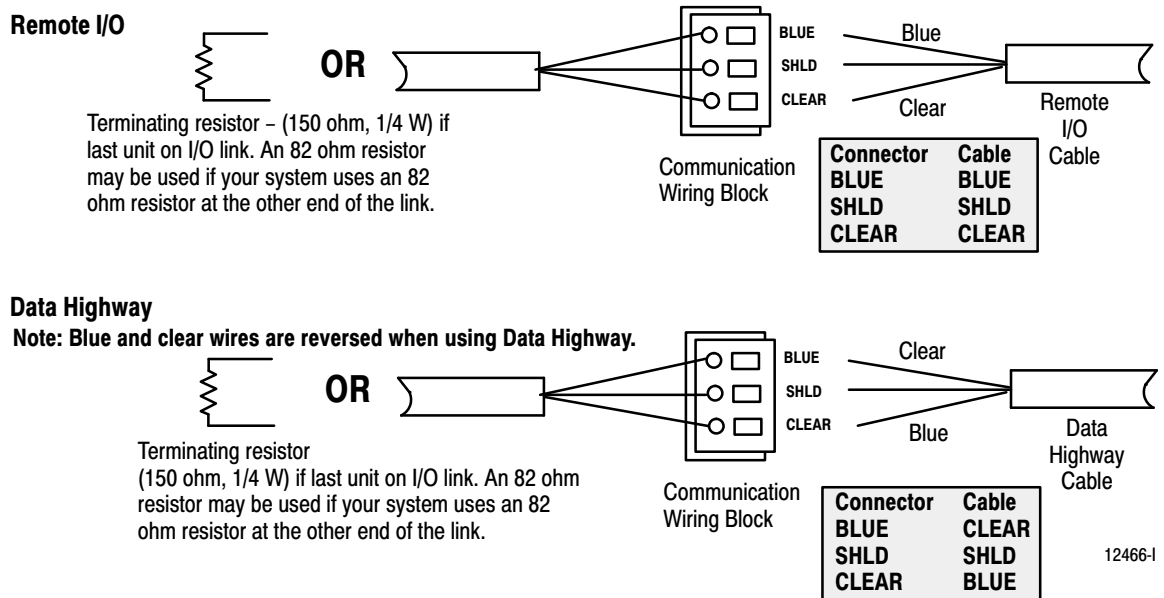

After connecting both input and communication wiring, set the switches (SW1 and SW2) on the front plate to match your application. Switch settings are shown in Figures 7 through 12.

Installing the I/O Modules

Install the I/O modules as follows:

1. Loosen the module latch locking screw and swing the latch up.



ATTENTION: Make certain the power switch on the 1771-AM is OFF before inserting or removing the I/O module. Failure to observe this warning could alter processor memory, damage the I/O module, and cause unintended operation which could possibly cause injury to personnel.

2. Insert the module as outlined in its accompanying publication.
3. Reposition module locking latch down over front of module and tighten screw.
4. Turn the power **ON** using the switch on the front plate.

Setting the Switches for Programmable Controller Configurations

Use Figures 7 through 12 for setting the configuration for the particular programmable controller you are using.

For:	Refer to:	On Page:
PLC-2 without Complementary I/O		Page
PLC-2 with Complementary I/O		Page
PLC-3		Page
PLC-5 without Complementary I/O		Page
PLC-5 with Complementary I/O		Page
PLC-5/250 and Bus Scanner		Page



ATTENTION: When changing the switch settings, make sure that the power switch on the front of the 1771-AM is **OFF**. Changing the switch settings with power on can result in memory corruption, and possible injury to personnel due to unexpected machine motion.



ATTENTION: When cycling power to the 1771-AM wait until all indicators are off before turning power back on.

Switch Setting Procedure

To set switches SW1 and SW2, proceed as follows:

1. Turn power switch OFF.
2. Position switches SW1 and SW2 as required for your particular application (Figures 7 through 12).
3. Turn power switch ON.

Figure 7	8
Figure 8	9
Figure 9	10
Figure 10	11
Figure 11	12
Figure 12	13

Installation Instructions
 1-Slot and 2-Slot I/O Chassis with
 Integral Power Supply and Adapter

Figure 7
Switch Settings for PLC-2 without Complementary I/O

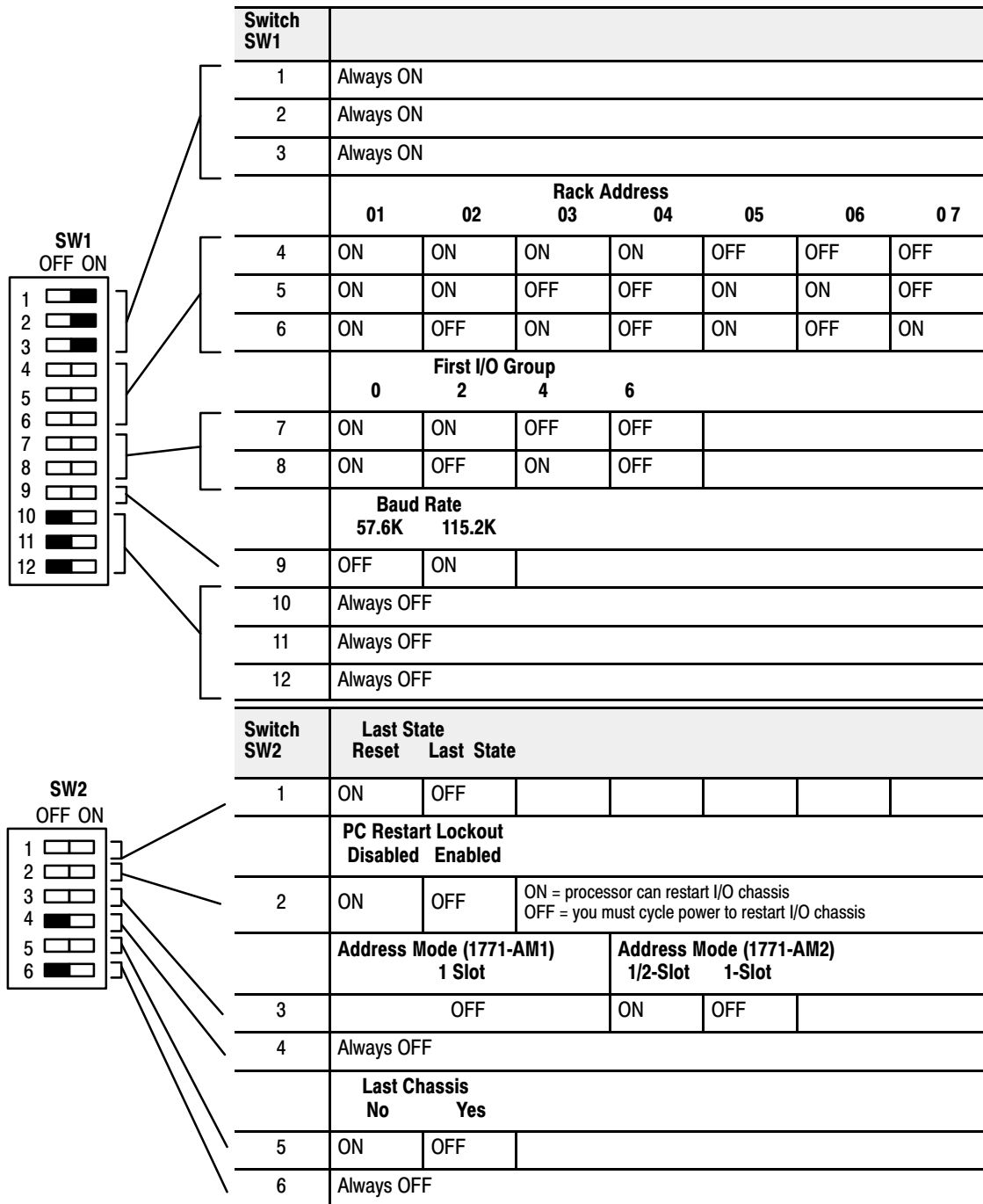
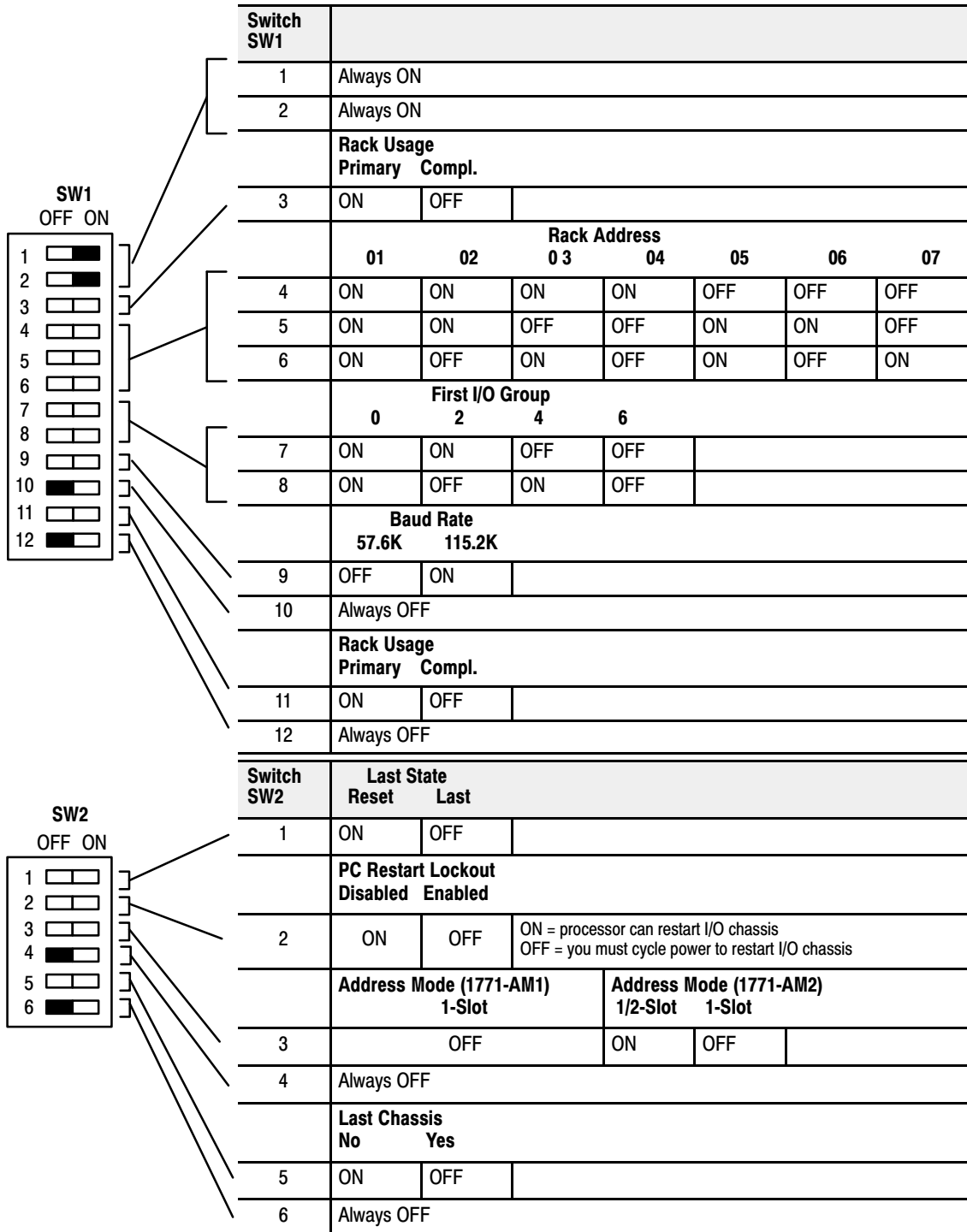

Figure 8
Switch Settings for PLC-2 with Complementary I/O



Installation Instructions
 1-Slot and 2-Slot I/O Chassis with
 Integral Power Supply and Adapter

Figure 9
Switch Settings for PLC-3

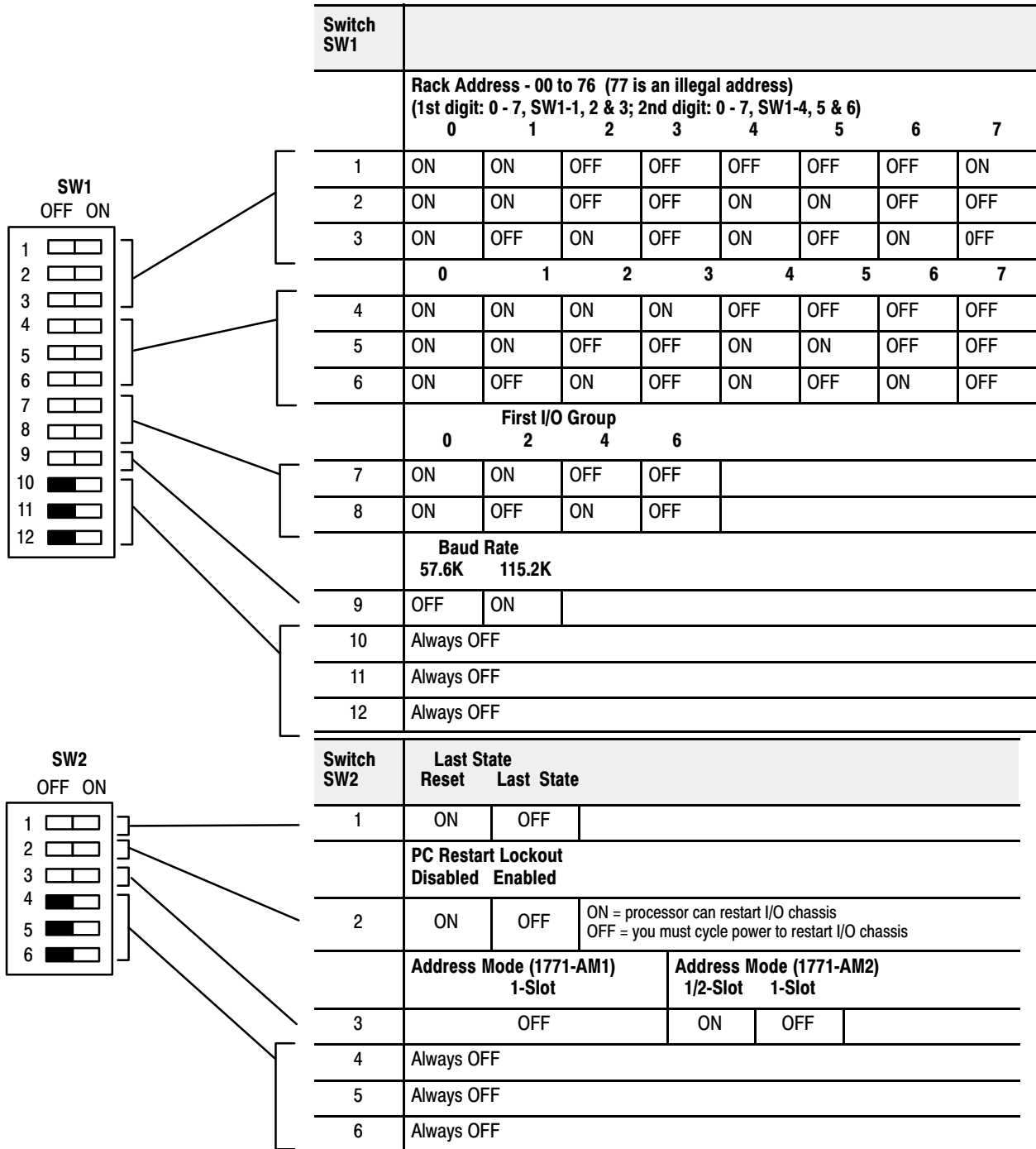
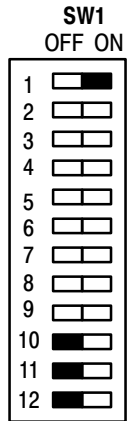
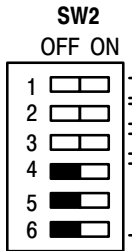

Figure 10
Switch Settings for PLC-5 without Complementary I/O



Switch SW1										
1	Always ON									
		Rack Address - 00 to 27 (1st digit: 0 - 2, SW1-2, 3; 2nd digit: 0 - 7, SW1-4, 5 & 6)								
		0	1	2						
2	ON	ON	OFF							
3	ON	OFF	ON							
		01	02	03	04	05	06	07	07	
4	ON	ON	ON	ON	OFF	OFF	OFF	OFF	OFF	
5	ON	ON	OFF	OFF	ON	ON	OFF	OFF	OFF	
6	ON	OFF	ON	OFF	ON	OFF	ON	OFF	OFF	
		First I/O Group								
		0	2	4	6					
7	ON	ON	OFF	OFF						
8	ON	OFF	ON	OFF						
		Baud Rate 57.6K 115.2K								
9	OFF	ON								
10	Always OFF									
11	Always OFF									
12	Always OFF									

PLC-5/11 processors can scan rack 03.
 PLC-5/15 and PLC-5/20 processors can scan racks 01-03.
 PLC-5/25 and PLC-5/30 processors can scan racks 01-07.
 PLC-5/40 and PLC-5/40L processors can scan racks 01-17.
 PLC-5/60 and PLC-5/60L processors can scan racks 01-27.
 PLC-5/250 processors can scan racks 0-37.
 PLC-3 processors can scan racks 0-76.



Switch SW2	Last State				
	Reset	Last			
1	ON	OFF			
		PC Restart Lockout		ON = processor can restart I/O chassis OFF = you must cycle power to restart I/O chassis	
		Disabled	Enabled		
2	ON	OFF			
		Address Mode (1771-AM1)		Address Mode (1771-AM2)	
		1-Slot		1/2-Slot	1-Slot
3	OFF		ON	OFF	
4	Always OFF				
5	Always OFF				
6	Always OFF				

Installation Instructions
 1-Slot and 2-Slot I/O Chassis with
 Integral Power Supply and Adapter

Figure 11
Switch Settings for PLC-5 with Complementary I/O

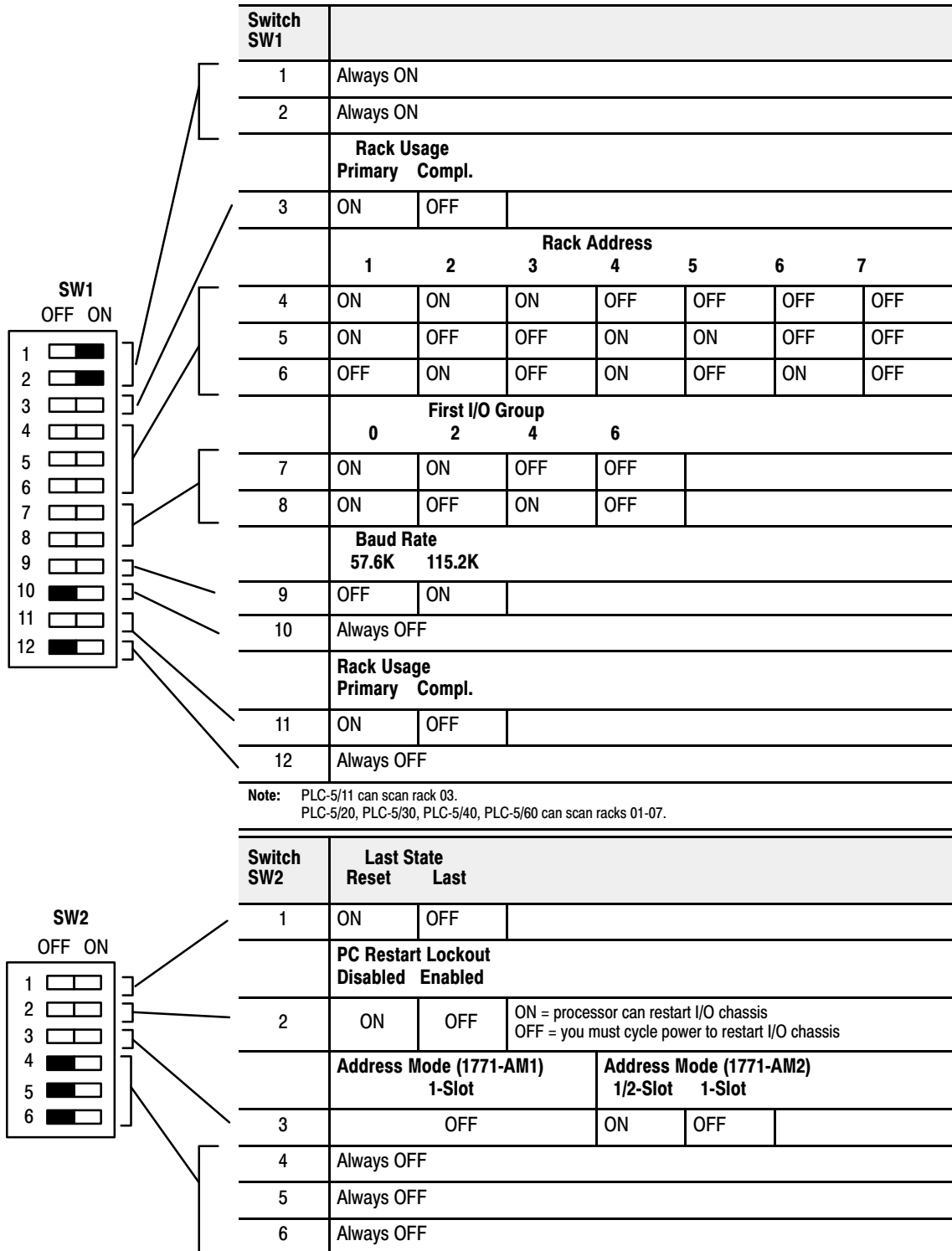
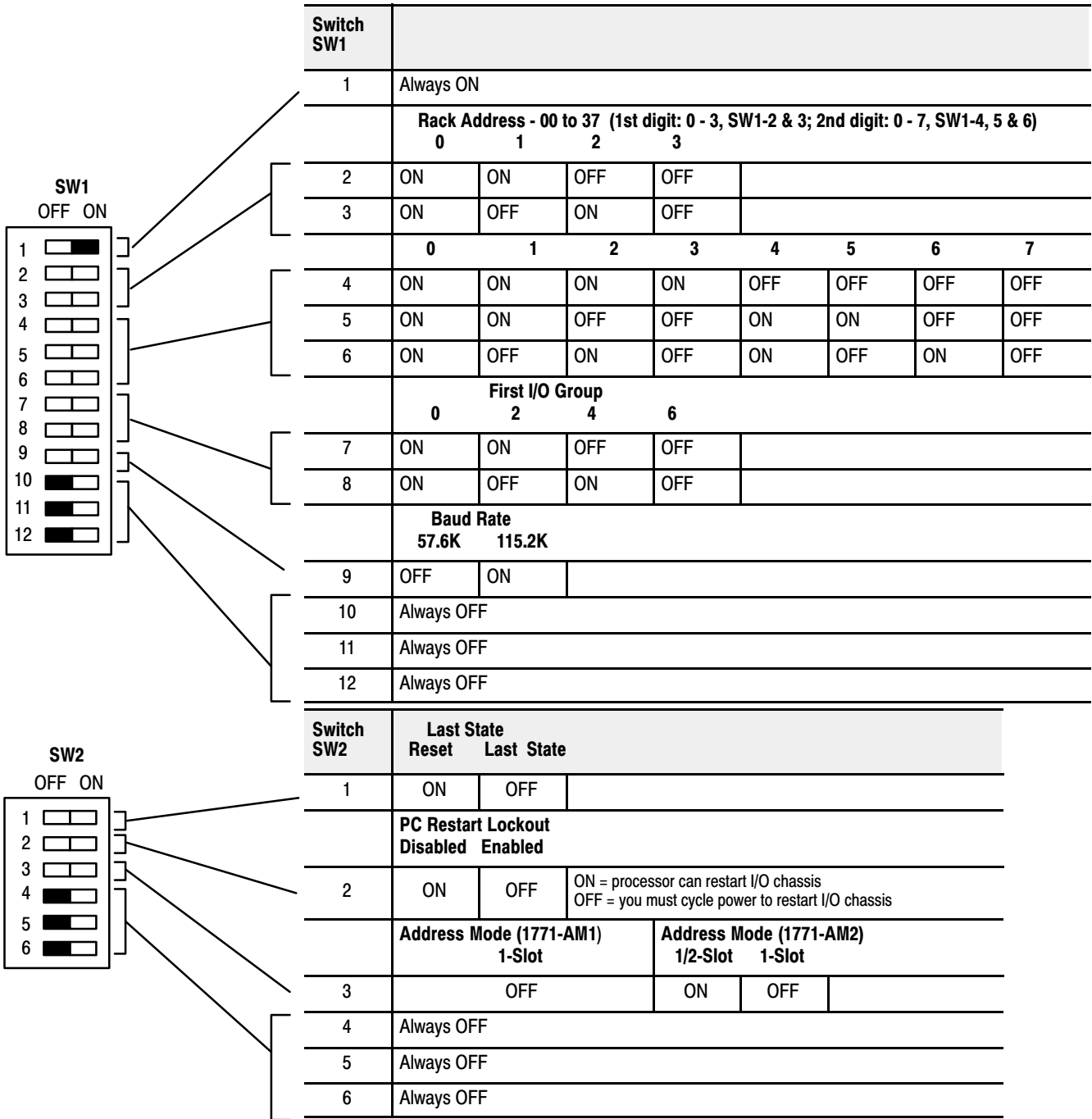

Figure 12
Switch Settings for PLC-5/250 and Bus Scanner



Interpreting the Indicators

Use the indicators on the front of the unit as a troubleshooting aid. Refer to Table A for information on what the indications mean.

Figure 13
1771-AM1 and -AM2 Indicators

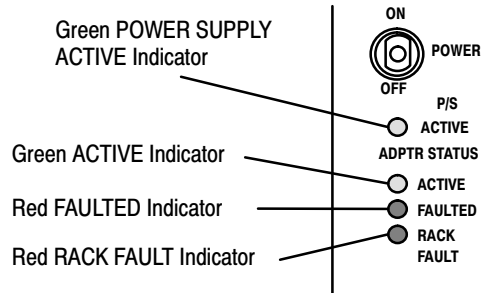

12467-1

Table A
Using the Indicators as a Troubleshooting Guide

Indicator	Indication	Description of problem	Probable Cause	Recommended Action
POWER SUPPLY SECTION				
P/S Active	On	Power supply is operating normally		
P/S Active	Off	The power supply has detected one of the following conditions: dc overvoltage dc undervoltage dc overcurrent ac undervoltage	dc overvoltage, dc undervoltage, dc overcurrent, or ac undervoltage	Turn power supply OFF. Remove I/O module. Wait 15 seconds and turn power ON. If LED is still off, and ac voltage is okay, replace 1771-AM. If LED is on, turn power OFF, reseat I/O module, wait 15 seconds and turn power ON. If LED is OFF, replace I/O module and try again. If LED is still OFF, replace 1771-AM.
REMOTE I/O ADAPTER SECTION				
Active Adapter Fault I/O Rack Fault	On Off Off	Normal indication; 1771-AM is fully operational		
Active Adapter Fault I/O Rack Fault	On or off On On or off	1771-AM fault ²	1771-AM not operating; it will stay in fault mode until fault is corrected	Cycle power to the 1771-AM to clear the adapter fault ³ . Replace 1771-AM if fault does not clear.
Active Adapter Fault I/O Rack Fault	Off or Blinking Off On	I/O chassis fault ²	Problem exists between: o 1771-AM and I/O module; the module will stay in fault mode until fault is corrected o shorted printed circuit board runs on backplane or I/O module	Cycle power to the chassis to clear a problem resulting from high noise ³ o remove and replace I/O module in -AM chassis o replace 1771-AM
Active Adapter Fault I/O Rack Fault	Blinking Off Off	1771-AM not actively controlling I/O (scanner to 1771-AM communication link is normal) ⁴	Processor is in program or test mode Scanner is holding adapter module in fault mode	Fault should be cleared by I/O scanner

Indicator	Indication	Description of problem	Probable Cause	Recommended Action
Active Adapter Fault I/O Rack Fault	Blinking alternately Off	Adapter module not actively controlling I/O ² Adapter module in processor restart lockout mode (adapter to scanner link is normal)	Processor restart lockout switch on SW2 switch assembly on ¹	Cycle power ³ . If after repeated attempts indicators are still blinking, check: o communication connector not connected to adapter module o adapter module was reset by processor/scanner, then immediately faulted
Active Adapter Fault I/O Rack Fault	Off Off Off	If remote I/O scanner/distribution panel (1772-SD, -SD2) is in disable search mode, then response is normal ⁵	Power supply fault Wiring from scanner to adapter module disrupted Scanner not configured properly One faulted chassis within rack group address causing scanner/distribution panel to fault all chassis in rack group address (when in disable search mode)	Check power supply, cable connections, and make sure adapter module is fully seated in chassis. Correct cable and wiring defects Refer to publication 1772-2.18 for scanner configuration Check sequentially from the first module to the last module to pinpoint fault; correct any faults and proceed to the next chassis
Active Adapter Fault I/O Rack Fault	Blinking On On	Module identification line fault	Excessive noise on backplane	Verify power supply and chassis grounding
Active Adapter Fault I/O Rack Fault	Both flash in unison Off	Incorrect starting I/O group number for chassis size	Error in starting I/O group number or I/O rack address	Verify acceptable beginning I/O group number; set switches correctly

¹ You must select the operating mode of the remote I/O adapter module as outlined in the publication furnished with the remote I/O scanner/distribution panel, remote I/O scanner-program interface module, or I/O scanner-message handling module. Pay close attention to the disable search mode in the 1772-SD, -SD2.

² The I/O chassis is in faulted mode as selected by the last state switch.

³ Cycling power clears the block-transfer request queue. All pending block transfers are lost. Your program must repeat the request for block transfers from the chassis.

WARNING: When cycling power to the 1771-AM, wait until all indicating LEDs are off before turning power back on.

⁴ If a fault occurs and the processor is in the run mode but is actually operating in the dependent mode, the chassis fault response mode is selected by the last state switch.

⁵ The I/O chassis is in faulted mode as selected by the last state switch.

Installation Instructions
1-Slot and 2-Slot I/O Chassis with
Integral Power Supply and Adapter

Specifications

General		1771-AM1	1771-AM2
Dimensions	Inches Millimeters	2.875 x 11.75 x 7.375 73 x 298.5 x 187.3	5.0 x 11.75 x 7.375 127 x 298.5 x 187.3
Weight		3 lbs (1.35Kg)	5 lbs (2.27Kg)
I/O Module Capacity		1 single-slot I/O module	2 single-slot or 1 double-slot I/O module
Conductors	- Wire Size - Category	14 gauge (2mm ²) stranded (max); 3/64 inch insulation (max) 1 ¹	
Environmental Conditions	Operating Temperature Storage Temperature Relative Humidity	0° to 60°C (32° to 140°F) -40° to 85°C (-40° to 185°F) 5 to 95% (without condensation)	
Power Supply Section			
Nominal Input Voltage		120V ac @ 50/60 Hz; 220V ac @ 50/60 Hz (switch selectable)	
Input Voltage Range		97 - 132V ac rms; 194 - 264V ac rms	
Input Power	(Real/Apparent)	30W/48VA	
External Transformer		75VA at full load	
Input Voltage Frequency		47 - 63 Hz	
Isolation Voltage		2500V dc for 1 second	
Fuse		1.5A, Slow-Blow	
Power Supply Output Voltage		5.1V dc (±3.8%)	
Power Supply Output Current		3.5A	
Power Loss Time Delay		13.6ms (±2.96ms)	
Backplane Current		3A available for I/O Modules	
Adapter Section			
Baud Rate (bps)		57.6K; 115.2K	
Chassis Distance		5,000 ft @ 115.2K bps; 10,000 ft @ 57.6K bps	
Removable Wiring Blocks			
Communication Wiring Block		A-B PN 940611-03 - Phoenix Terminal Blocks, Inc., PN 1752179	
Input Wiring Block		A-B PN 941274-03 -Wago, PN 231-203/000-008	

¹ Refer to publication 1770-4.1, Industrial Automation Wiring and Grounding Guidelines

PLC is a registered trademark of Allen-Bradley Company, Inc.



Allen-Bradley has been helping its customers improve productivity and quality for 90 years. A-B designs, manufactures and supports a broad range of control and automation products worldwide. They include logic processors, power and motion control devices, man-machine interfaces and sensors. Allen-Bradley is a subsidiary of Rockwell International, one of the world's leading technology companies.

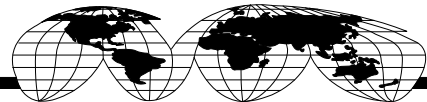

With major offices worldwide.

- Algeria • Argentina • Australia • Austria • Bahrain • Belgium • Brazil • Bulgaria • Canada • Chile • China, PRC • Colombia • Costa Rica • Croatia • Cyprus • Czech Republic • Denmark • Ecuador • Egypt • El Salvador • Finland • France • Germany • Greece • Guatemala • Honduras • Hong Kong • Hungary • Iceland • India • Indonesia • Israel • Italy • Jamaica • Japan • Jordan • Korea • Kuwait • Lebanon • Malaysia • Mexico • New Zealand • Norway • Oman • Pakistan • Peru • Philippines • Poland • Portugal • Puerto Rico • Qatar • Romania • Russia-CIS • Saudi Arabia • Singapore • Slovakia • Slovenia • South Africa, Republic • Spain • Switzerland • Taiwan • Thailand • The Netherlands • Turkey • United Arab Emirates • United Kingdom • United States • Uruguay • Venezuela • Yugoslavia

World Headquarters, Allen-Bradley, 1201 South Second Street, Milwaukee, WI 53204 USA, Tel: (1) 414 382-2000 Fax: (1) 414 382-4444