



AC (120/220V) 16A Power Supply

(Cat. No. 1771-P7 Series B)

Installation Instructions

To the Installer

This document provides information on:

- preparing to install the power supply
- installing the power supply
- connecting ac power to the power supply
- troubleshooting
- specifications

Prepare for Installation

The 1771-P7 power supply can power one 1771-A1B, -A2B, -A3B, -A3B1, or -A4B I/O chassis when used with any adapter module or programmable controller (Mini-PLC-2/02[®], Mini-PLC-2/05[®], Mini-PLC-2/16[®], Mini-PLC-2/17[®], or PLC-5[™] family processor) that does not have an internal power supply.

Important: The power supply is **not compatible** with the 1771-A1, -A2, or -A4 I/O chassis.



ATTENTION: The 1771-P7 is a stand-alone power supply. Do not connect it in parallel with any other power supply. Connecting it in parallel could result in processor memory loss or injury due to unexpected machine operation.



ATTENTION: Under some conditions, electrostatic discharge can degrade performance or damage system components. Observe the following precautions to guard against electrostatic damage:

- Touch a grounded object to rid yourself of charge before handling a module.
 - Do not touch the backplane connector or connector pins.
 - When not in use, keep modules in their static-shield bags.
-

Installation Data

AC (120/220 V) 16A Power Supply
1771-P7 Series B

Before installing the power supply, you should:

- mount the I/O chassis that the power supply will be connected to. See the Universal I/O Chassis Installation Data (1771-2.210) for information on mounting the I/O chassis.
- set the power supply configuration jumper on the I/O chassis. The 1771-P7 is an external power supply. Set the configuration jumper to the N position.

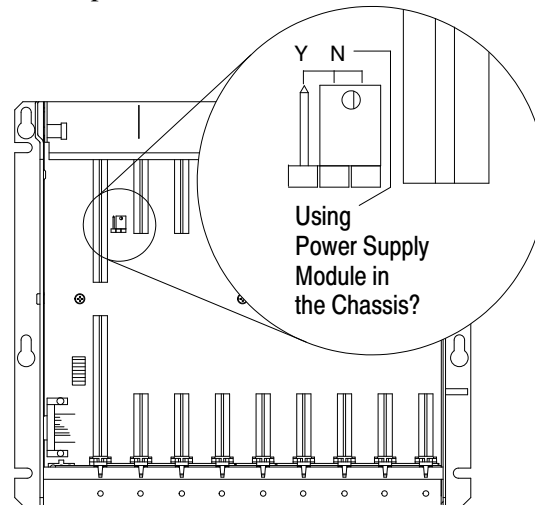

12620-1

Install the 1771-P7 and Connect Backplane Power

The power supply has a D-shell power connector that provides power to the I/O chassis backplane.

- A1 backplane common
- A2 backplane +5V dc
- 1 no connection
- 2 backplane processor enable
- 3 backplane +5V dc sense
- 4 backplane signal ground sense
- 5 no connection

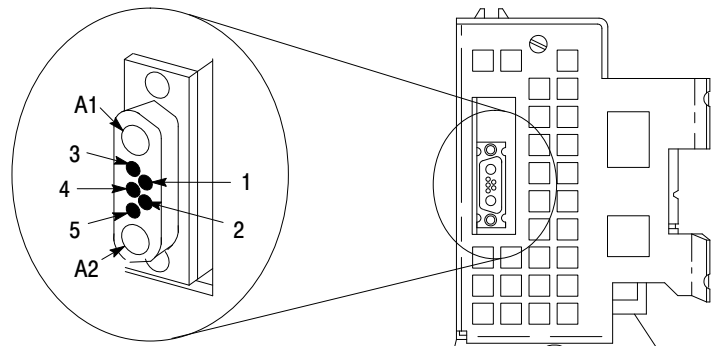

bottom view of power supply

13445

If You Have This I/O Chassis	Use this Power Cable	To Connect A 1771-P7 Mounted
1771-A3B	1771-CP2	within 1.52m (5ft) of the I/O chassis
1771-A1B, -A2B, -A3B1, or -A4B	1771-CP1	within 0.32m (1.04ft) on the left-side of the I/O chassis
	1771-CP3 (right angle connector)	within 1.68m (5.5ft) of the I/O chassis

If You Are Mounting the Power Supply	Go To
on the left side of a panel-mounted I/O chassis	next section
separately from an I/O chassis	page 5

Attaching to a Panel-mounted I/O Chassis

1. Attach the mounting screws to the side of the I/O chassis as shown:



ATTENTION: Use the mounting screws provided with the 1771-P7. Longer screws may intrude into the I/O chassis and interfere with module insertion.

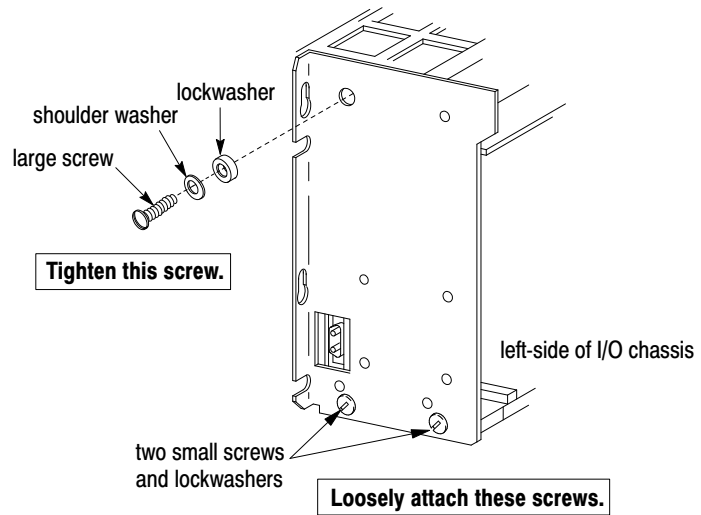

13446

2. Connect the power cable (ordered separately) to the D-shell connector on the I/O chassis and tighten the connector screws.

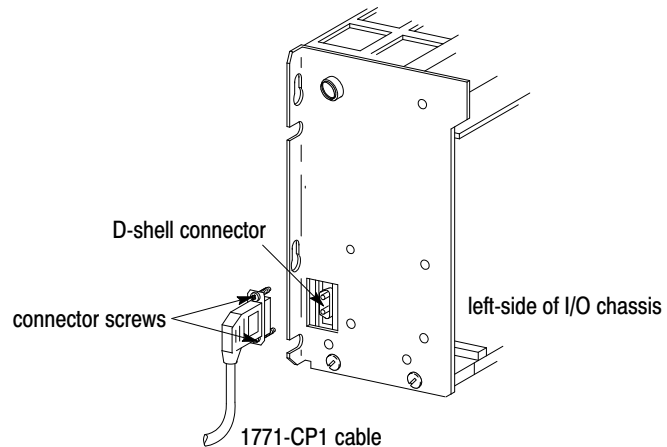

13447

Installation Data

AC (120/220 V) 16A Power Supply

1771-P7 Series B

3. Slide the power supply onto the left side of the chassis, as shown:

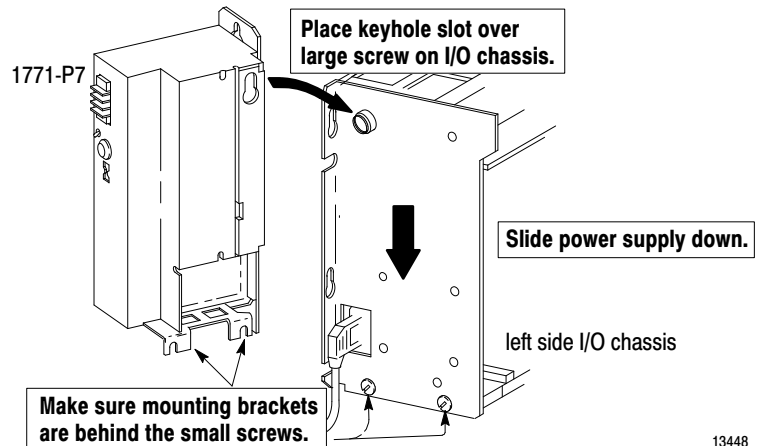

4. Tighten the small screws to secure the power supply to the I/O chassis.

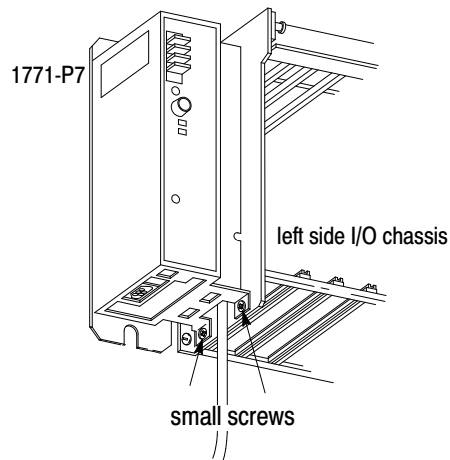

5. Attach the other end of the power cable to the D-shell connector on the bottom of the power supply and tighten the connector screws.

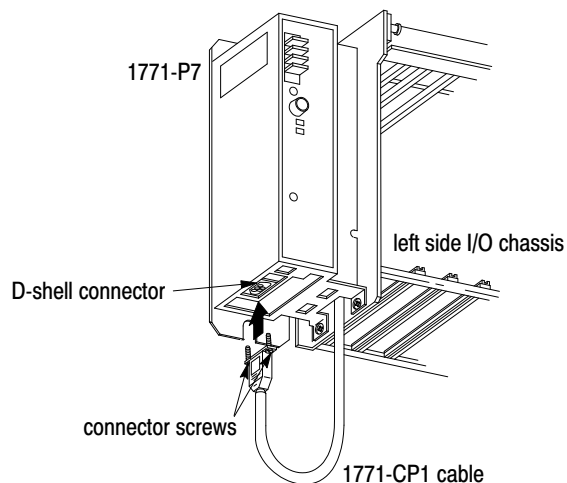

Mounting the Power Supply Separately

When mounted separately, the power supply may be mounted above or next to the I/O chassis. It may **not** be mounted below, since it is necessary to allow convection cooling of both the power supply and the I/O chassis. A minimum vertical distance of 6 inches should be maintained.

1. Mount the power supply vertically, above and within the specified cable-feet (for your cable) of the D-shell connector on the I/O chassis.

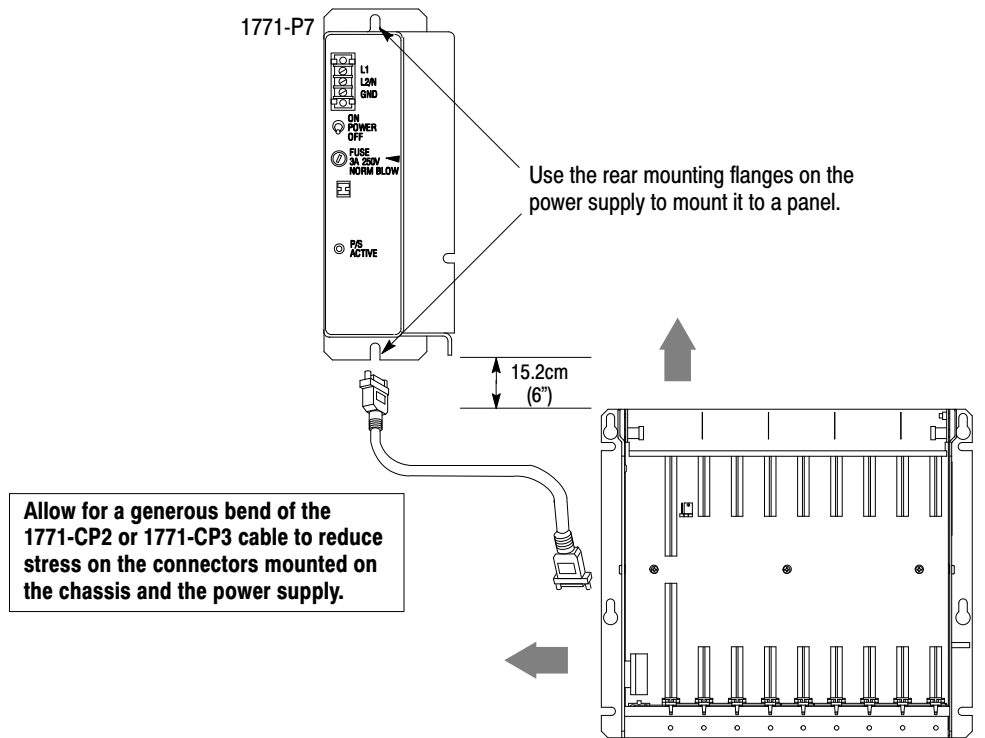

2. Connect one end of the power cable (ordered separately) to the D-shell connector located on the bottom of the power supply and tighten the connector screws.

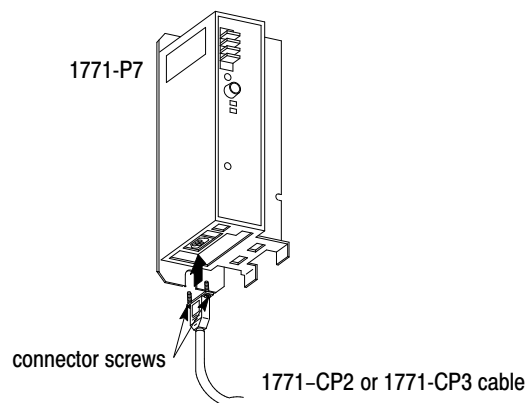

Installation Data

AC (120/220 V) 16A Power Supply

1771-P7 Series B

3. Connect the other end of the power cable to the D-shell connector on the I/O chassis and tighten the connector screws.

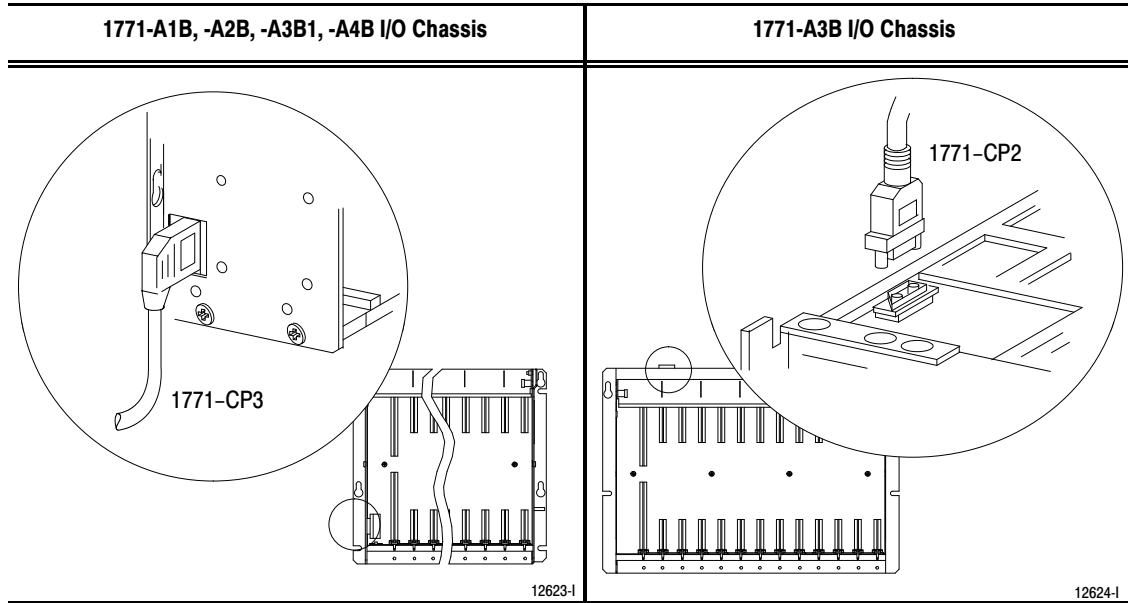

Connect ac Power Source to the Power Supply

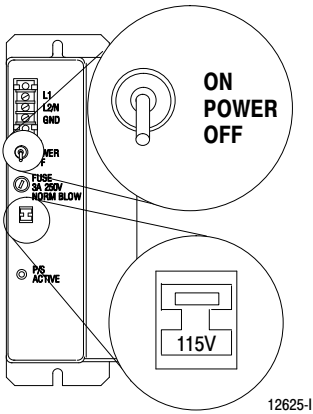



The power supply operates on nominal 120V ac or 220V ac input source.

1. Make sure the power switch is set to OFF.
2. Use a 1/8" slotted screwdriver to set the input voltage selector switch.



ATTENTION: To avoid damaging the power supply, do not place the screwdriver blade more than 3/8" into the switch slot.

For an Input Voltage of	Set the Voltage Selector Switch to
97 to 132V ac	115 position 
195 to 264V ac	230 position 

3. Connect the ac power line to the terminal strip on the power supply.



ATTENTION: You must connect a 14 AWG wire from the GND terminal to the ground bus to provide an adequate safety ground.

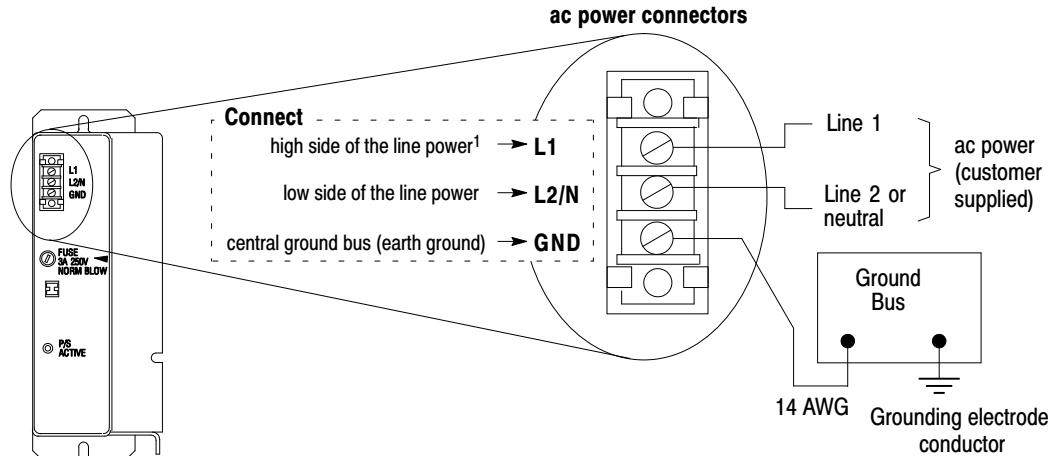

¹ A 3A 250V normal-blow fuse protects the input line L1 from drawing more than 3 amperes.

12626-1

Troubleshooting

The power supply has a green P/S ACTIVE LED that provides status indication during power supply operation.

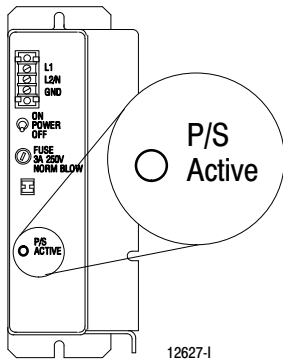

12627-1

Normal Operation	If Indicator Is	Then
on	off	it may be due to: <ul style="list-style-type: none"> • input voltage not within specified range • blown fuse • overcurrent



ATTENTION: If a shutdown condition occurs, wait 15 seconds before attempting to apply power.

For additional assistance, contact your local Allen-Bradley representative.

Installation Data

AC (120/220 V) 16A Power Supply
1771-P7 Series B

Specifications

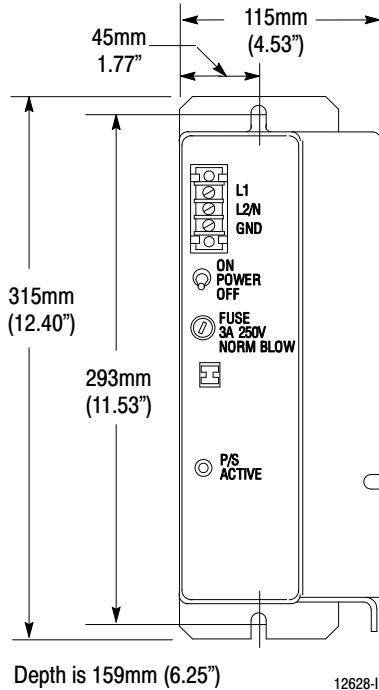

Nominal Input Voltage/Current	120V ac @ 2.0A 220V ac @ 1.0A
Input Voltage Range	120V ac: 97-132V ac 220V ac: 195-264V ac
Input Power (Real/Apparent)	108 Watts/176VA
External Transformer	270VA at full load
Frequency Range	47-63Hz
Isolation Voltage	2500V dc for 1s } input power to chassis ground 1800V ac (rms) for 1s }
Output Voltage	5.06V dc \pm 3.8%
Output Current	16A max @ 5V dc
Power Loss Time Delay — Input Power to Processor Disable	13.6msec \pm 2.9ms
Fuse	3A, 250V 3AG normal blow (Bussmann AGC 3 — Littelfuse 312003)
Weight	1.95kg (4.3 lbs.)
Dimensions (H x W x D)	315mm x 115mm x 159mm (12.40" x 4.53" x 6.25")
Environmental Conditions	Operating Temperature: 32 to 140° F (0 to 60° C) Storage Temperature: -40 to 185° F (-40 to 85° C) Relative Humidity: 5 to 95%, non-condensing
Cables	1771-CP1: 0.32m (1.04ft) — connects panel mounted I/O chassis to chassis mounted 1771-P7 1771-CP2: 1.52m (5ft) — connects rack-mounted I/O chassis to remote 1771-P7 1771-CP3: 1.68m (5.5ft) — connects panel-mounted I/O chassis to remote 1771-P7

Power Ratings

Use these graphs to determine your:

- cooling requirements
- power cost
- transformer size (unless the transformer manufacturer has a recommended multiplier for sizing a transformer for an ac-to-dc power supply)

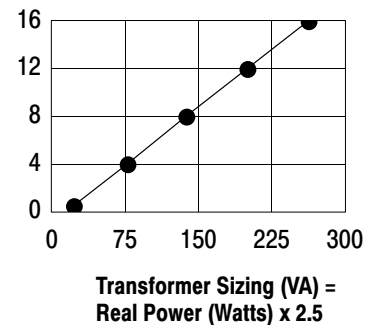
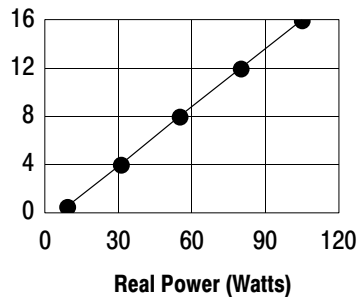
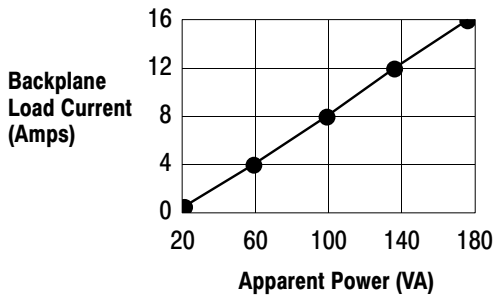

PLC-2/02, PLC-2/05, PLC-2/16, and PLC-2/17 are registered trademarks of Allen-Bradley Company, Inc.

PLC-5 is a trademark of Allen-Bradley Company, Inc.



With offices in major cities worldwide