



# AC/DC (120V) Input Module

## Cat. No. 1771-IAD Series C

### Installation Instructions

#### To The Installer

This document provides information on:

- important pre-installation considerations
- power supply requirements
- initial handling procedures
- installing the module
- using the indicators for troubleshooting
- module specifications

#### Pre-installation Considerations

The 1771-IAD Series C module is compatible with all chassis except the 1771-A1, 1771-A2 and 1771-A4 chassis. Make sure no other input module or single card block transfer module is placed in the same module group when using 2-slot addressing. Any discrete output module may be used within the same module group.

#### Power Requirements

Your module receives its power through the 1771 I/O chassis backplane from the chassis power supply. The module requires 195mA from the output of this supply. Add this to the requirements of all other modules in the I/O chassis to prevent overloading the chassis backplane and/or chassis power supply.

#### Initial Handling

The ac/dc input module is shipped in a static-shielded bag to guard against electrostatic discharge damage. Observe the following precautions when handling the module.



**ATTENTION:** This module is equipped with a plastic cover that is unique to all assembly numbers with the prefix 961440. (This part number is located near the backplane edge connector pins on the component-side of the circuit board.) Do not use this plastic cover on any other module.

---

## Electrostatic Discharge Damage



**ATTENTION:** Under some conditions, electrostatic discharge can degrade performance or damage the module. Observe the following precautions to guard against electrostatic damage.

- Wear an approved wrist strap grounding device, or touch a grounded object to discharge yourself before handling the module.
- Do not touch the backplane connector or connector pins.
- If you configure or replace internal components, do not touch other circuit components inside the module. If available, use a static-free work station.
- When not in use, keep the module in its static-shielded bag.

## Installing Your Module

In this section, we tell you how to:

- change the delay time jumper
- key your I/O chassis
- install your module
- make your wiring connections

### Changing the Delay Time Jumper

Your module is equipped with an adjustable delay time jumper. Use the jumper to select between two input channel delay times. The delay time you choose applies to all sixteen of the module's channels.

Use this delay time:	If you want:
5ms	to detect typical input readings
20ms	to prevent detection of false inputs in high-noise environments

The module is shipped with the delay time jumper preset to 5ms. To change the delay time jumper to 20ms, do the following:

1. Locate the delay time jumper selection plug at the top-right edge of the module circuit board, as shown in the following figure.
2. Use your finger to slide the jumper off the 5ms position (the middle post and the right post).
3. Carefully reposition the jumper by sliding it onto the 20ms position (the middle post and the left post).

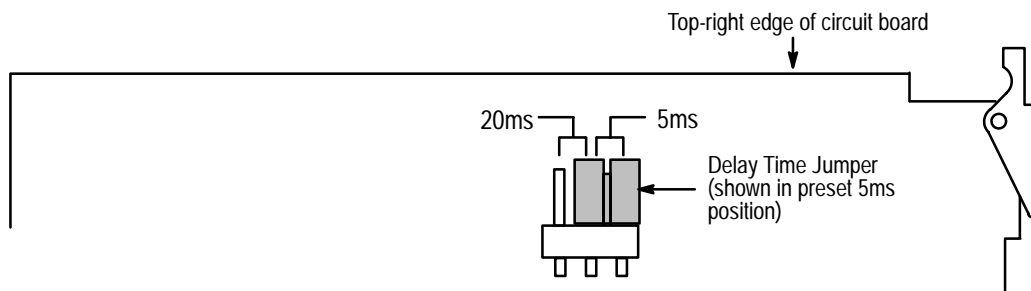

12636-I

## Keying Your I/O Chassis

Use the plastic keying bands, shipped with each I/O chassis, to key the I/O slots to accept only this type of module.

The module circuit board is slotted in two places on the rear edge. The position of the keying bands on the backplane connector must correspond to these slots to allow insertion of the module. You can key any connector in an I/O chassis to receive this module except for the left-most connector reserved for adapter or processor modules. Place keying bands between the following numbers labeled on the backplane connector:

- Between 10 and 12
- Between 14 and 16

You can change the position of these keys if system redesign and rewiring makes insertion of a different module necessary.

## Installing Your Input Module

To install the ac/dc input module in your 1771 I/O chassis, follow the steps listed below.



**ATTENTION:** Remove power from the 1771 I/O chassis backplane and field wiring arm before removing or installing an I/O module.

- Failure to remove power from the backplane or field wiring arm could cause module damage, degradation of performance, or injury.
  - Failure to remove power from the backplane could cause injury or equipment damage due to possible unexpected operation.
- 

1. Turn off power to the I/O chassis.
2. Place the module in the plastic tracks on the top and bottom of the slot that guides the module into position.
3. Do not force the module into its backplane connector. Apply firm, even pressure on the module to seat it properly.
4. Snap the chassis latch over the top of the module to secure its position.
5. Connect the field wiring arm to the module.
6. Make wiring connections to the field wiring arm as indicated in Figure 1.

### Connecting Wiring to the Input Module

Connections to the input module are made to the field wiring arm (cat. no. 1771-WH) shipped with the module. Attach the field wiring arm to the pivot bar on the bottom of the I/O chassis. The field wiring arm pivots upward and connects with the module so you can install or remove the module without disconnecting the wires.

**Figure 1**  
**Connection Diagram**

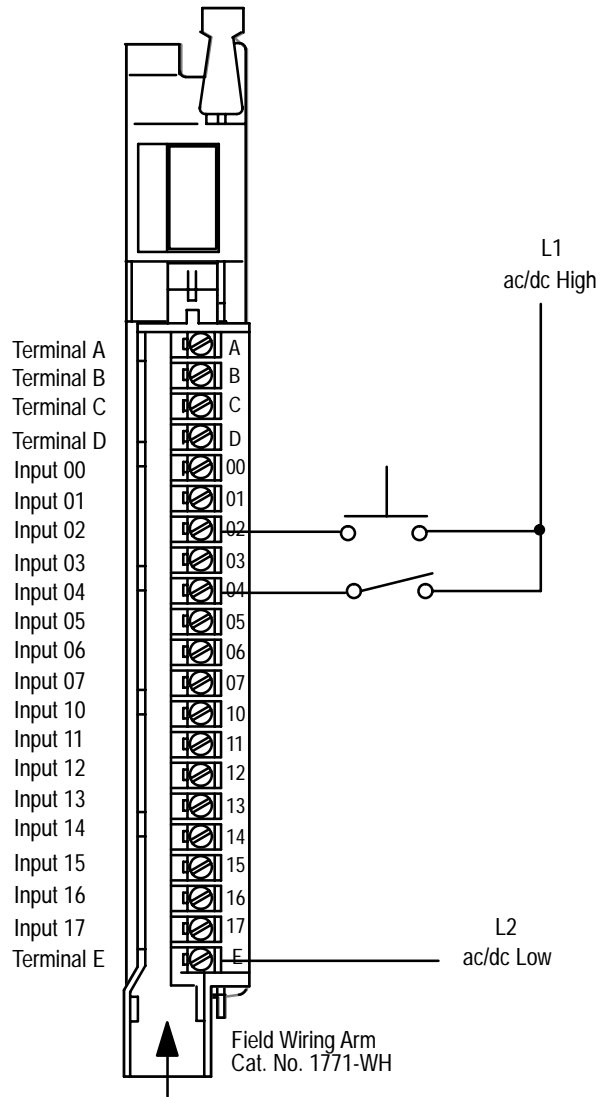

(Actual wiring runs in this direction.)

10589-1

Connect one terminal of your 2-wire input device to terminals 00 thru 17 (Figure 1). Connect L1 (high) ac/dc line to the other terminal of your input devices. Connect terminal E to the L2 (low) ac/dc return. Terminals A thru D are not used. Use stranded 14 or 16 gauge wire to minimize the voltage drop over long cable distances.

**Important:** You can use an AC (120V) Output Module (cat. no. 1771-OAD) to directly drive terminals on an AC/DC (120V) Input Module (cat. no. 1771-IAD) (Figure 2).

**Figure 2**  
**Driving a 1771-IAD Module with a 1771-OAD Module**

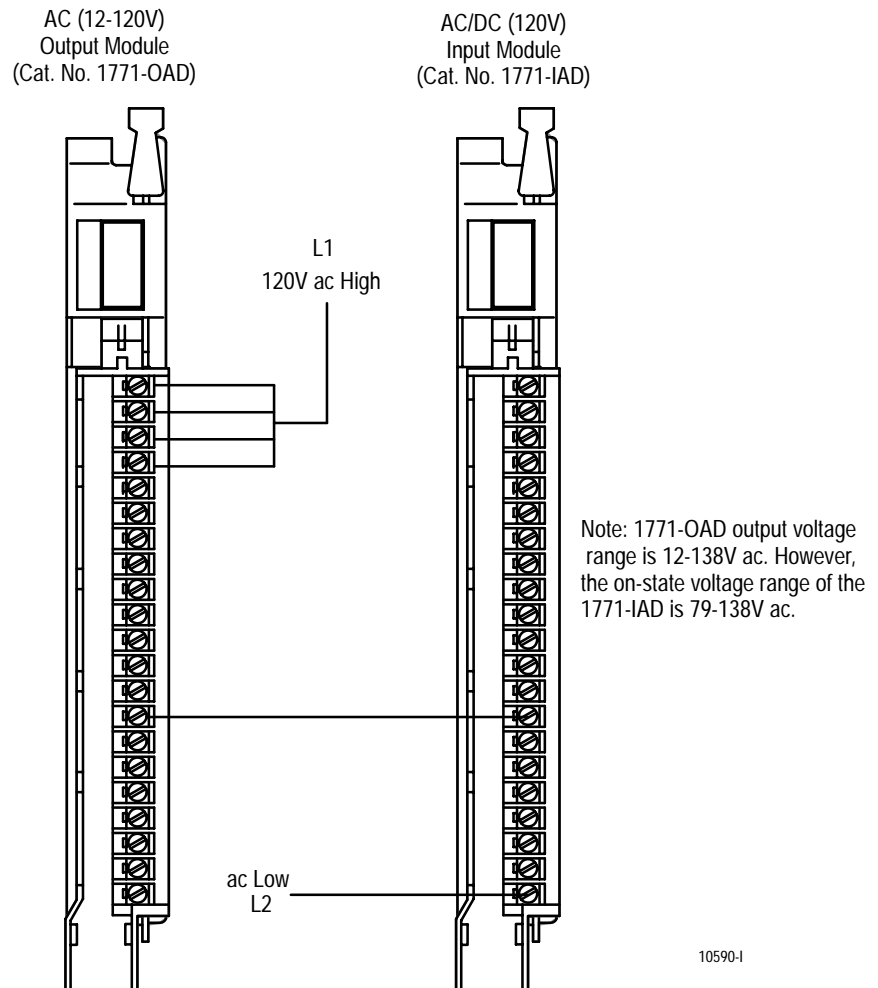

You can also use a 1771-OA Output module to drive an AC/DC (120V) Input Module (cat. no. 1771-IAD) but you must connect one of the following between the output terminal and L2 (common) (Figure 3).

- 2500 ohm, 10W resistor
- RG-1676-1 Electrocube (San Gabriel, California)

**Use the same ac power source to power both modules to ensure proper phasing and prevent module damage.**

## Installation Instructions

AC/DC (120V) Input Module  
Cat. No. 1771-IAD Series C

**Figure 3**  
Driving a 1771-IAD Module with a 1771-OA Module

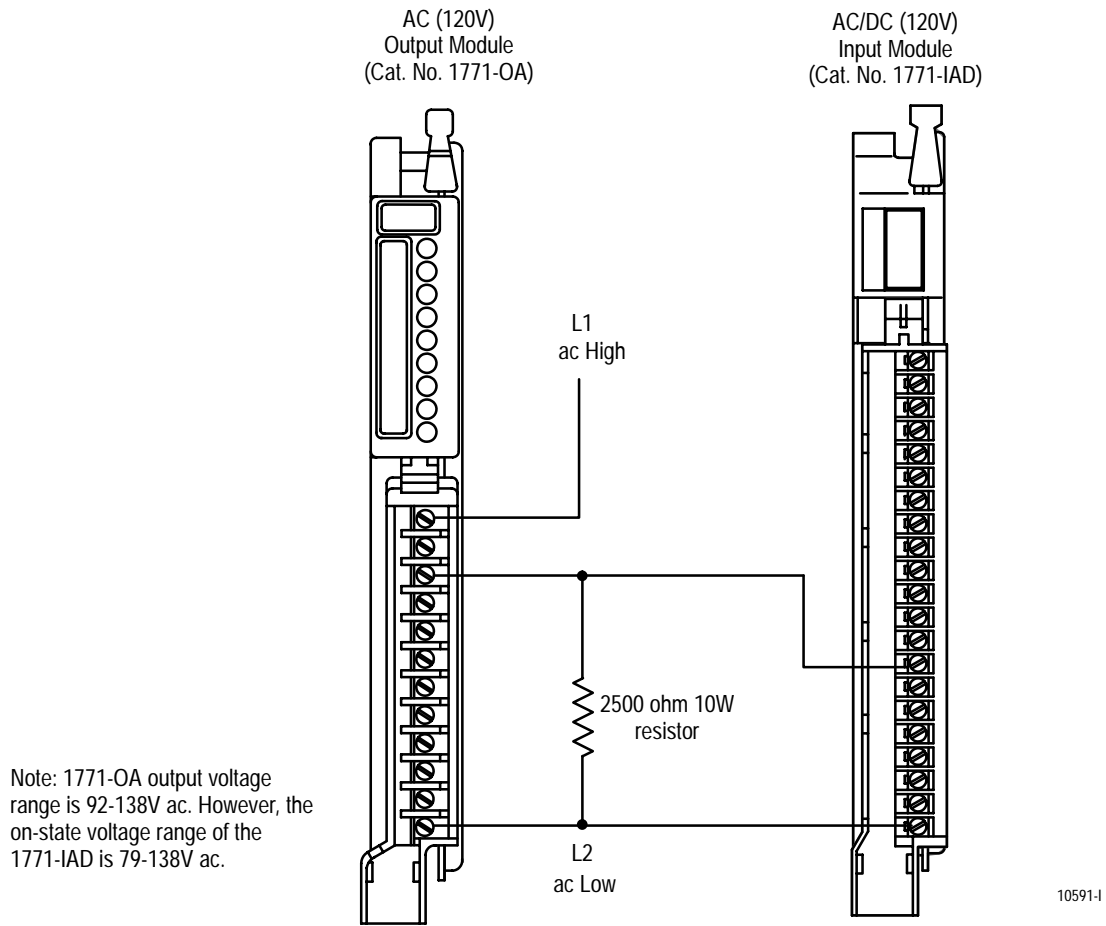

## Interpreting the Status Indicators

The front panel of your module contains one green module active indicator, and 16 red status indicators (figure 4).

When the green module active indicator lights, the rack power supply has properly established 5Vdc. To properly interpret the red status indicators, the module active indicator must be lit.

The red status indicators are provided for system logic side indication of individual inputs. When a red indicator lights, voltage is present on the terminal. The module transfers this information to the backplane for the processor to read. See “Troubleshooting” for a description, probable cause, and recommended action to take for common faults based on indicator responses.

**Figure 4**  
**Status Indicators**

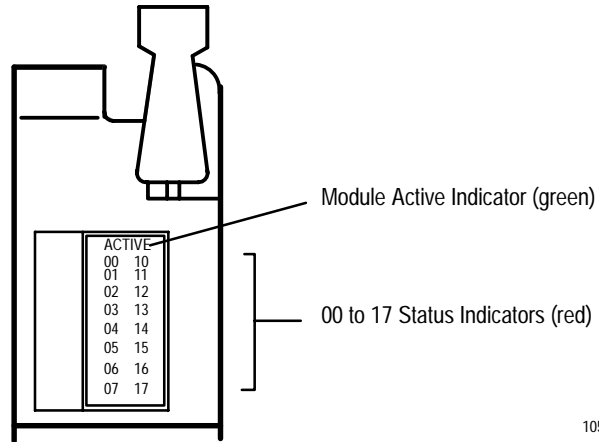

10592-1

**Troubleshooting**

Use this table to help you interpret the 1771-IAD status indicators and to troubleshoot module and system faults.

Indicator Status (color)	Description of Fault or System Status	Action to Take
Module active ON (green)	Normal Indication	None
Module active ON (green) and Input status ON (red)	Check for voltage on terminal.	If voltage is present, take no action. If no voltage is present, replace the module.
Module active ON (green) and Input status OFF	Input devices not functioning properly or faulty input circuitry on module.	1. Check input devices. 2. If input devices are OK, replace module.
	No voltage on terminal.	None
Module active OFF and Input status ON (red) or OFF	Not valid unless module active indicator is on; when active is off, indicators do not represent processor status.	1. Check chassis power supply and module input power. 2. If power supplies are OK, replace module.

## Installation Instructions

AC/DC (120V) Input Module  
Cat. No. 1771-IAD Series C

## Specifications

Inputs per Module	16
Module Location	1771 Series B or later I/O chassis, 1771-AM1, -AM2 chassis
Nominal Input Voltage	120V ac @ 50/60Hz; 125V dc
Nominal Input Current	9.9mA @ 120V ac 60Hz; 8.7mA @ 120V ac 50Hz; 2.56mA @ 125V dc
On-state Voltage Range	79V to 138V ac or dc
Minimum On-state Current	5.95mA @ 79V ac 60Hz; 1.5mA @ 79V dc
Maximum Off-state Voltage	43V ac or dc
Maximum Off-state Current	3.0mA @ 43V ac 60Hz; 0.8mA @ 43V dc
Input Impedance	11.2K ohms @ 60Hz (0.18 microfarad in parallel with 47K ohms, in series with 820 ohms)
Peak Inrush Current	Inrush = $V_{PS}/820$ ohm, where $V_{PS}$ = customer supply peak voltage
Input Signal Delay	Off to On 5ms ( $\pm 3$ ms) or 20ms ( $\pm 5$ ms) @ 120V ac 60Hz selectable On to Off 3ms ( $\pm 1$ ms) or 10ms ( $\pm 1$ ms) @ 120V dc selectable 25ms ( $\pm 5$ ms) @ 120V ac or dc
Power Dissipation	8.8 Watts (max.), 1.0 Watts (min.)
Thermal Dissipation	30.1 BTU/hr (max.), 3.42 BTU/hr (min.)
Backplane Current	195mA @ 5V
Isolation Voltage	Tested at 2500V dc for 1 second per UL508 & CSA C22.2 #142
Environmental Conditions	
Operational Temperature	0° to 60°C (32° to 140°F)
Storage Temperature	-40° to 85°C (-40° to 185°F)
Relative Humidity	5 to 95% (without condensation)
Conductors	Wire Size 14 gauge stranded maximum 3/64 inch insulation maximum
	Category 1 <sup>1</sup>
Keying	Between 10 and 12 Between 14 and 16
Field Wiring Arm	Catalog Number 1771-WH
Wiring Arm Screw Torque	7-9 inch-pounds

<sup>1</sup> Refer to publication 1770-4.1, Programmable Controller Wiring and Grounding Guidelines.



**ALLEN-BRADLEY**  
A ROCKWELL INTERNATIONAL COMPANY

Allen-Bradley has been helping its customers improve productivity and quality for 90 years. A-B designs, manufactures and supports a broad range of control and automation products worldwide. They include logic processors, power and motion control devices, man-machine interfaces and sensors. Allen-Bradley is a subsidiary of Rockwell International, one of the world's leading technology companies.



With major offices worldwide.

Algeria • Argentina • Australia • Austria • Bahrain • Belgium • Brazil • Bulgaria • Canada • Chile • China, PRC • Colombia • Costa Rica • Croatia • Cyprus • Czech Republic • Denmark • Ecuador • Egypt • El Salvador • Finland • France • Germany • Greece • Guatemala • Honduras • Hong Kong • Hungary • Iceland • India • Indonesia • Israel • Italy • Jamaica • Japan • Jordan • Korea • Kuwait • Lebanon • Malaysia • Mexico • New Zealand • Norway • Oman • Pakistan • Peru • Philippines • Poland • Portugal • Puerto Rico • Qatar • Romania • Russia-CIS • Saudi Arabia • Singapore • Slovakia • Slovenia • South Africa, Republic • Spain • Switzerland • Taiwan • Thailand • The Netherlands • Turkey • United Arab Emirates • United Kingdom • United States • Uruguay • Venezuela • Yugoslavia

World Headquarters, Allen-Bradley, 1201 South Second Street, Milwaukee, WI 53204 USA, Tel: (1) 414 382-2000 Fax: (1) 414 382-4444