



AC (120V) Isolated Output Module, 16 Outputs

Cat. No. 1771-OD16 Series B

To The Installer

This document provides information on:

- important pre-installation considerations
- power supply requirements
- installing the module
- using the module indicators for troubleshooting
- replacing a fuse
- module specifications

Pre-installation Considerations

An output from this module can drive an Allen-Bradley Size 5 motor starter, provided its supply voltage does not drop below 92V ac. The maximum load current the module can deliver is 2A per channel, not to exceed 8A total per module.

Your module's outputs can drive the following motor starter combinations:

- 16 size 3 motor starters (1 per output)
- 10 size 4 motor starters (1 per output)
- 7 size 5 motor starters (1 per output)

The switching device in the output circuit is a solid-state triac. There is a small leakage current in the off state due to both triac and capacitive characteristics. The maximum leakage current per output is 3mA at 138V ac. Nominal leakage current is 1.5mA. The on-state voltage drop across the output terminals will not exceed 1.5V ac at 2A.

The 1771-OD16/B module is designed for a 5mA minimum current on each output circuit. The total continuous current the module supports is 8A (2A maximum per channel).



ATTENTION: If the 8A maximum per module (2A per module) rating is exceeded, the module overheats and damage may occur.

The module uses zero voltage turn-on to reduce the electromagnetic interference and high inrush currents during initial turn-on. This zero crossing feature switches line voltage only when it is close to zero. The typical value for zero crossing voltage is ± 15 V ac.

This module can be used in all 1771 I/O chassis except the 1771-A1, -A2 or -A4 chassis. It may also be used in a 1771-AM1 or 1771-AM2 chassis. This module is not compatible with the 1771-AL local I/O adapter module.

Suppression

Surge suppression circuitry is provided for the output triacs in this module. To suppress high-voltage transients from the AC line, a metal-oxide varistor (MOV) is provided between each set of terminals on the module. In each output circuit an RC network limits the magnitude of voltage transients that may occur when a device is wired in parallel or series with hard contacts.

Loads with inductive characteristics may require additional suppression devices. The impedance characteristic of the load is the most important factor in selecting a suppression device; thus no single suppression device can be recommended for every possible load. Acceptable suppression devices for typical loads are shown in the table below.

Allen-Bradley Equipment	Suppressor Catalog Number
Motor Starter Bulletin 509	599-K04 ¹
Motor Starter Bulletin 709	1401-N10 ¹
Relay Bulletin 700 Type N or P	700N5/700N9
Miscellaneous	700-N24 ²

¹ For starters with 120V AC coils

² Bulletin 700-N24 is a universal surge suppressor. You can use it on electromagnetic devices with the limitation of 35 sealed VA, 150V.

Power Supply Requirements

The isolated output module is powered by the power supply connected to the I/O chassis backplane. The module requires a maximum current of 250mA from the +5V dc output of this supply. Total the current requirements of this module with the other modules in the I/O chassis to avoid overloading the supply or the I/O chassis backplane.

Understand Compliance to European Union Directives

If this product has the CE mark it is approved for installation within the European Union and EEA regions. It has been designed and tested to meet the following directives.

EMC Directive

This product is tested to meet Council Directive 89/336/EEC Electromagnetic Compatibility (EMC) and the following standards, in whole or in part, documented in a technical construction file:

- EN 50081-2EMC – Generic Emission Standard, Part 2 – Industrial Environment
- EN 50082-2EMC – Generic Immunity Standard, Part 2 – Industrial Environment

This product is intended for use in an industrial environment.

Low Voltage Directive

This product is tested to meet Council Directive 73/23/EEC Low Voltage, by applying the safety requirements of EN 61131-2 Programmable Controllers, Part 2 – Equipment Requirements and Tests.

For specific information required by EN 61131-2, see the appropriate sections in this publication, as well as these Allen-Bradley publications:

- Industrial Automation Wiring and Grounding Guidelines For Noise Immunity, publication 1770-4.1
- Guidelines for Handling Lithium Batteries, publication AG-5.4
- Automation Systems Catalog, publication B111

Determining Module Placement in the I/O Chassis

You can place your module in any I/O module slot of the I/O chassis except for the left-most slot. The left-most slot is reserved for programmable controller processors or adapter modules. Group your modules to minimize adverse effects from radiated electrical noise and/or heat. We recommend the following:



ATTENTION: Remove power from the 1771 I/O chassis backplane and wiring arm before removing or installing an I/O module.

- Failure to remove power from the backplane or wiring arm could cause module damage, degradation of performance, or injury.
 - Failure to remove power from the backplane could cause injury or equipment damage due to possible unexpected operation.
-
- Group analog input and low voltage dc modules away from ac modules or high voltage dc modules to minimize electrical noise interference.
 - Place analog input modules and other I/O modules sensitive to heat away from slot power supplies to minimize adverse heat effects.

Initial Handling Procedures



ATTENTION: Remove power from the 1771 I/O chassis backplane and wiring arm before removing or installing an I/O module.

- Failure to remove power from the backplane or wiring arm could cause module damage, degradation of performance, or injury.
- Failure to remove power from the backplane could cause injury or equipment damage due to possible unexpected operation.

- Touch a grounded object to rid yourself of charge before handling the module.
- Do not touch the backplane connector or connector pins.
- When you configure or replace internal components, do not touch other circuit components inside the module. If available, use a static-safe work station.
- When not in use, keep the module in its static-shield bag.

Setting the Mode of the Fuse-Blown Jumper

The fuse-blown jumper has two modes:

- the preset, **standard (STD) mode** – displays the fuse status on the red fuse-blown status indicator
- the **customer side indication (CSI) mode** – displays the fuse status in the input image table **and** on the red fuse-blown status indicator. This mode configures the module as a 16 point output module that utilizes **both the output and input image data tables** of your controller. When a fuse blows, all 16 bits in the associated input image table will turn on (1).

For example, if you install the module in a PLC-5 system and address the module as O:012, then the fuse status bits are in I:012.

To monitor the status of the module fuses, make certain that your user program monitors the module's input image table for "on" bits.



ATTENTION: Do not put the module jumper in CSI mode when you use this module in a complementary mode. Your system will not operate properly.

To change the fuse blown jumper to the CSI mode:

1. Locate the fuse-blown jumper at the top-right edge of the module circuit board, as shown in the following figure.

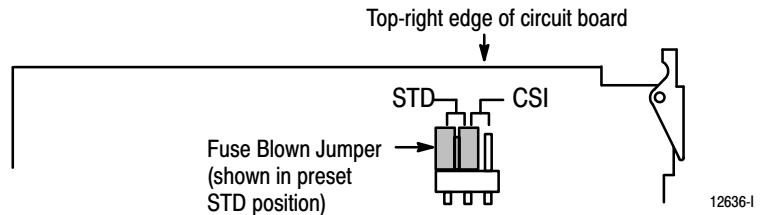

2. Use your finger to slide the jumper off the STD position (the middle post and the left post).
3. Carefully reposition the jumper by sliding it onto the CSI position (the middle post and the right post).

Key the Backplane Connector



ATTENTION: A module inserted into a wrong slot could be damaged by improper voltages connected through the wiring arm. Use keying bands to prevent damage to the module.

Place your module in any slot in the chassis except the leftmost slot which is reserved for processors or adapters.



ATTENTION: Observe the following precautions when inserting or removing keys:

- insert or remove keys with your fingers
- make sure that key placement is correct

Incorrect keying or the use of a tool can result in damage to the backplane connector and possible system faults.

Position the keying bands in the backplane connectors to correspond to the key slots on the module.

Place the keying bands:
between 22 and 24
between 34 and 36

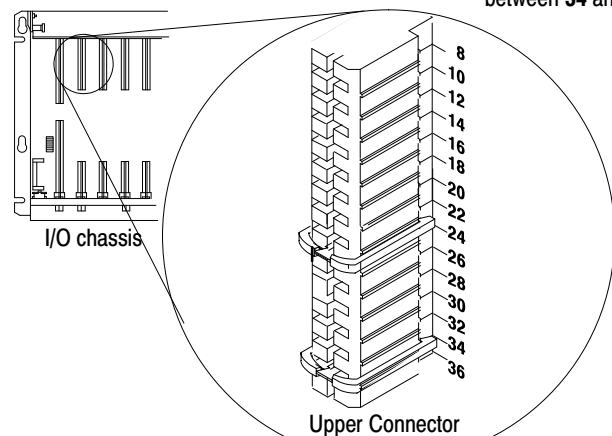

You can change the position of these bands if subsequent system design and rewiring makes insertion of a different type of module necessary.

11022-1

Install the Module and Field Wiring Arm



ATTENTION: Remove power from the 1771 I/O chassis backplane and field wiring arm before removing or installing an I/O module.

- Failure to remove power from the backplane or wiring arm could cause module damage, degradation of performance, or injury.
- Failure to remove power from the backplane could cause injury or equipment damage due to possible unexpected operation.

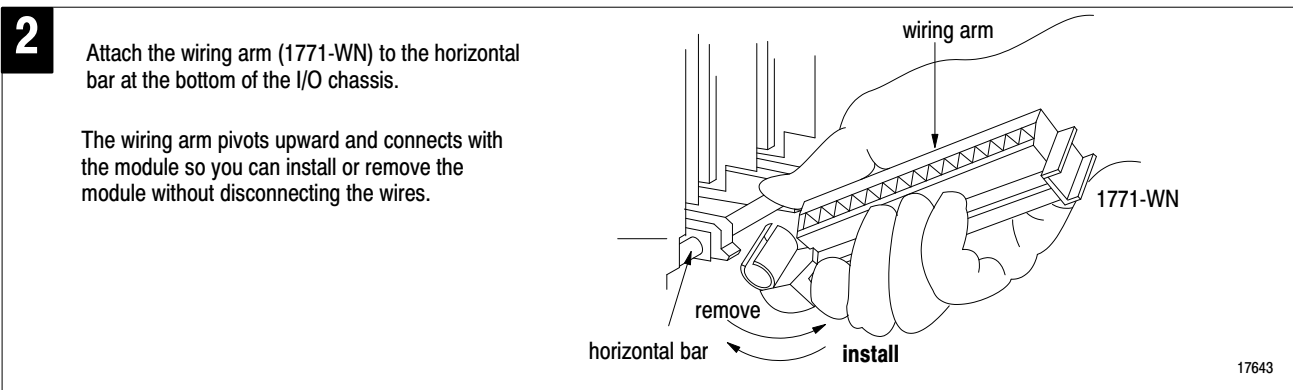
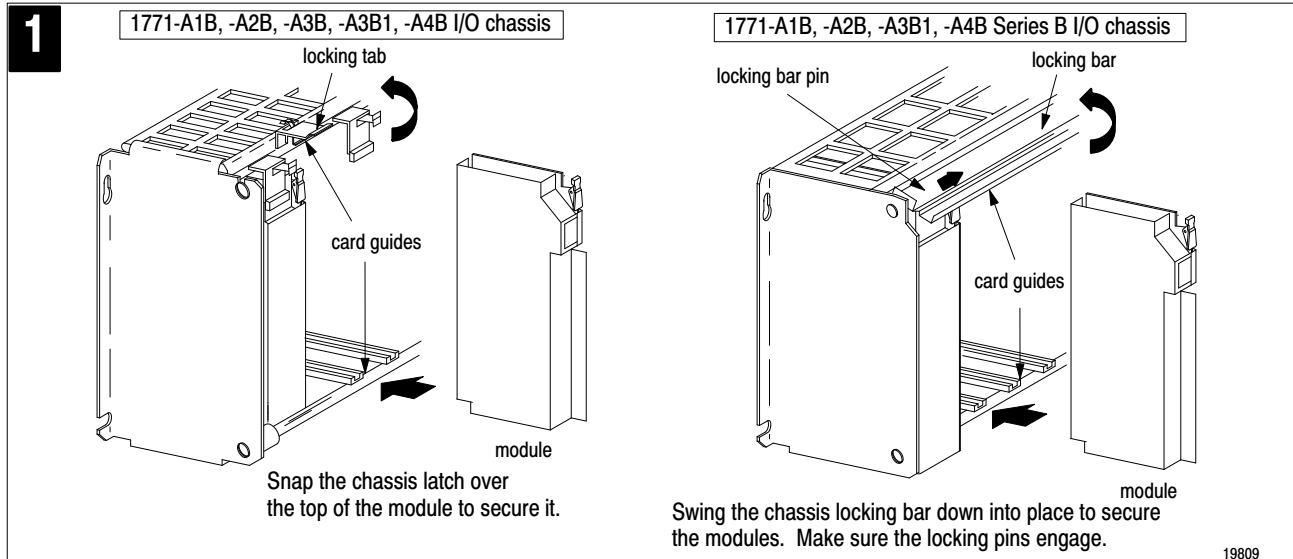

Connect the Wiring to the Module

You make connections to the module through the 1771-WN field wiring arm shipped with the module. The arm pivots on the chassis to connect with the terminals on the front of the module (as shown below). The wiring arm allows the module to be removed from the chassis without disconnecting wiring.

1. Make certain all power is removed from the module before making wiring connections.
2. Swing the wiring arm up into position on the front of the module. The locking tab on the module will secure it into place.
3. Make your connections to the field wiring arm as shown below. (Use the label on the front of the wiring arm to identify your wiring.)

Connecting Wiring for the 1771-OD16/B Isolated Output Module

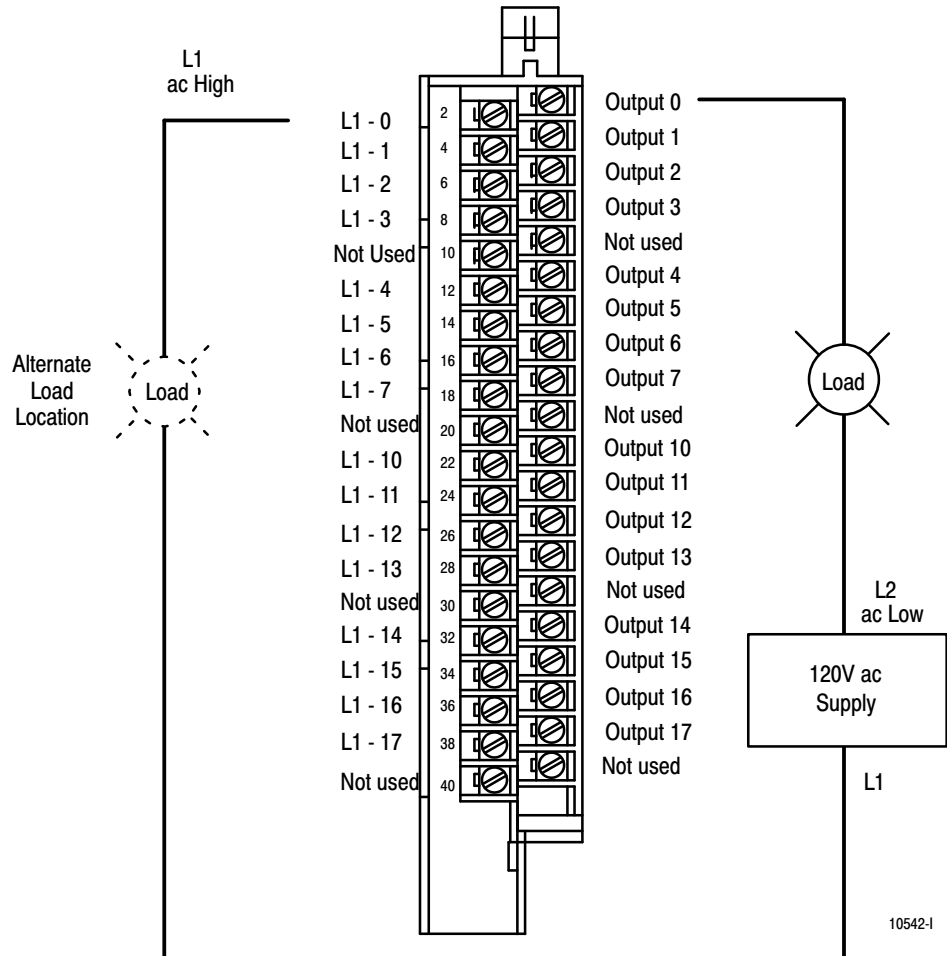

ATTENTION: The field wiring arm terminal identification number is not the same as the number of the bit which controls that output.

Note: You can use the shorting bar to connect the L1-0 through L1-17 high side ac power connections together **if no isolation is required.**

You can use an output of the 1771-OD16 module to drive an input of a 120V ac input module (1771-IA, -IA2, -IAD,-ID or ID16), as shown below, to indicate status of turning on a motor starter, for example. Inputs configured with the output module are not isolated from each other.



ATTENTION: Do not connect the 1771-OD16 output channels in series. Doing so can result in distortion of the output waveform causing the output devices to chatter.

Examples of the 1771-OD16/B Driving Input Modules

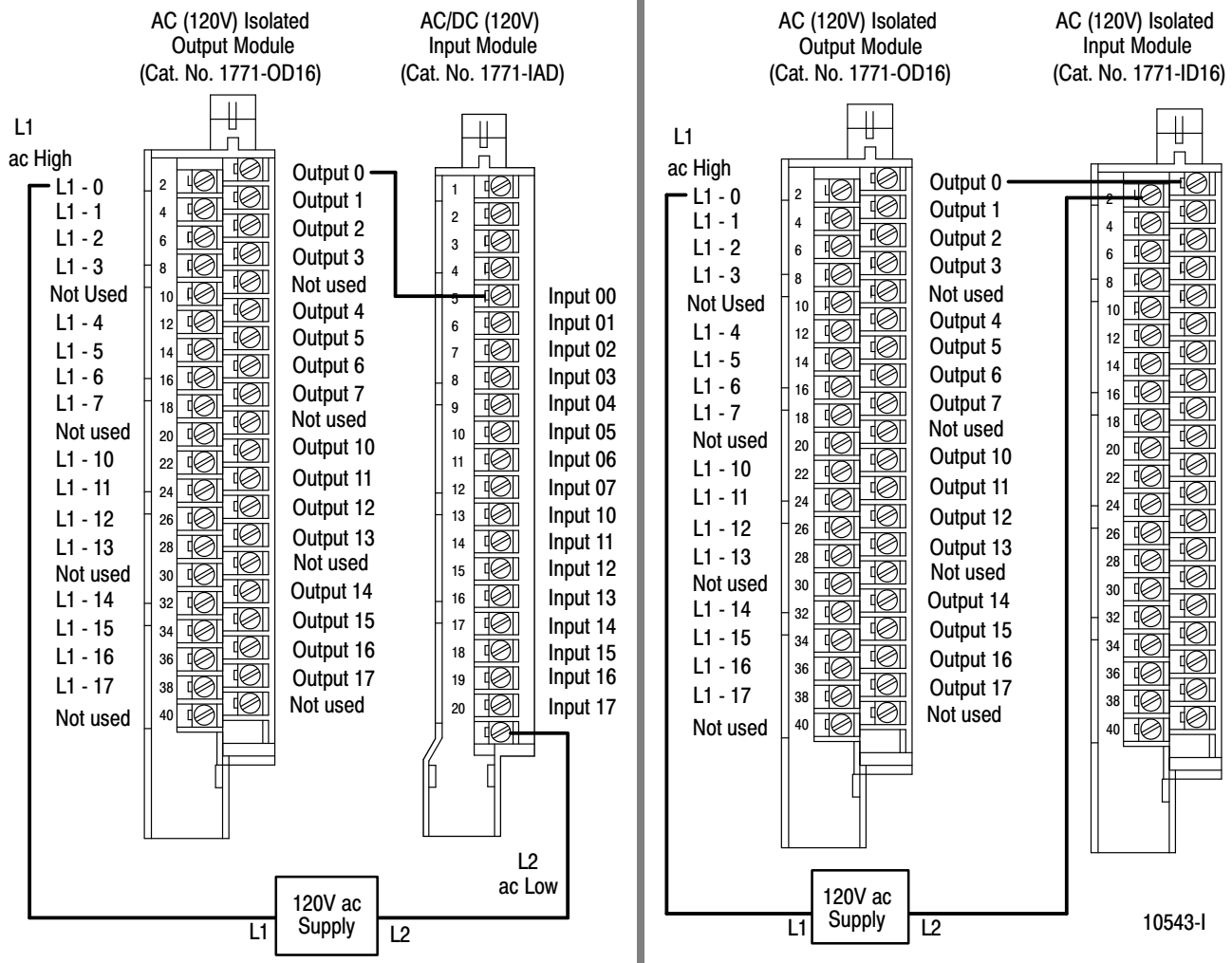

Interpreting the Status Indicators

The module has 18 indicators (below), consisting of 16 output status indicators, an active indicator and a fuse blown indicator. The 16 status indicators will light when an "on" signal has been communicated between the module and the system backplane.

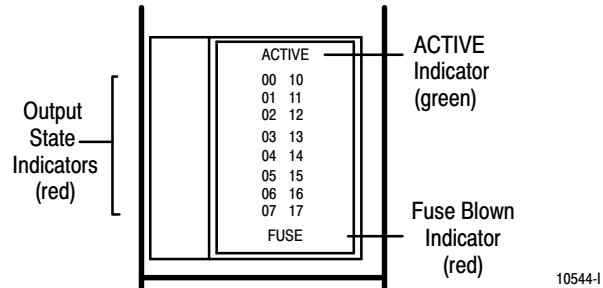

The ACTIVE indicator will light when the module has started up and successfully initialized. The FUSE blown indicator will light when the fuse has cleared or been removed and the channel associated with that fuse has been turned "on." The fuse-blown circuit will not operate if the applied voltage to that channel is above the specified minimum "on-state" voltage, and the output load current is less than or equal to 5mA. The FUSE blown indicator will reset after the fuse has been replaced and chassis power has been cycled.

Replacing a Fuse

Each module output is individually fused. You can easily access the module fuses through the access holes on the side cover. Follow the procedure below.



ATTENTION: Remove power from the 1771 I/O chassis backplane and wiring arm before removing or installing an I/O module.

- Failure to remove power from the backplane could cause injury or equipment damage due to possible unexpected operation.
- Failure to remove power from the backplane or wiring arm could cause module damage, degradation of performance, or injury.



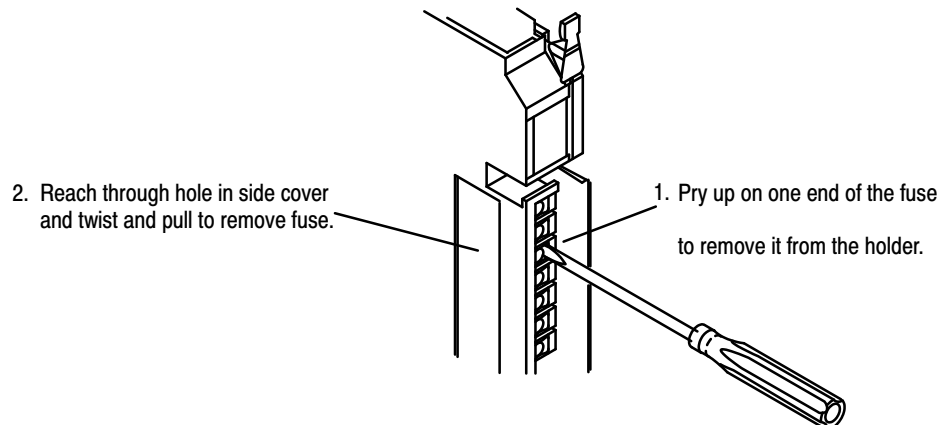

If a blown fuse occurs:

1. Turn off power to the I/O chassis backplane.
2. Pivot the wiring arm away from the module and pull the module from the I/O chassis.
3. Use a small common screwdriver to reach through the front of the module and carefully pry one end of the fuse out of its holder.

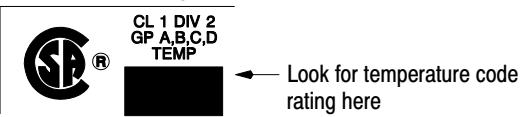
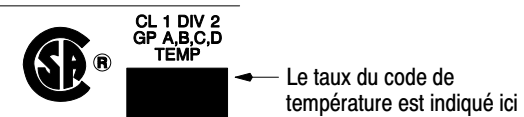

18532

4. Reach through the access hole on the side of the module and carefully twist and pull to remove the blown fuse. Replace it with a 3A 2AG slo-blow fuse (Littelfuse part number 229003).
5. Reinstall the module in the I/O chassis.
6. Reposition the wiring arm.
7. Restart system power.

<p>CSA Hazardous Location Approval</p>	<p>Approbation d'utilisation dans des emplacements dangereux par la CSA</p>
<p>CSA® certifies products for general use as well as for use in hazardous locations. Actual CSA certification is indicated by the product label as shown below, and not by statements in any user documentation.</p>	<p>La CSA® certifie les produits d'utilisation générale aussi bien que ceux qui s'utilisent dans des emplacements dangereux. La certification CSA en vigueur est indiquée par l'étiquette du produit et non par des affirmations dans la documentation à l'usage des utilisateurs.</p>
<p>Example of the CSA certification product label</p> 	<p>Exemple d'étiquette de certification d'un produit par la CSA</p> 
<p>To comply with CSA certification for use in hazardous locations, the following information becomes a part of the product literature for CSA-certified Allen-Bradley industrial control products.</p> <ul style="list-style-type: none"> • This equipment is suitable for use in Class I, Division 2, Groups A, B, C, D, or non-hazardous locations only. • The products having the appropriate CSA markings (that is, Class I Division 2, Groups A, B, C, D), are certified for use in other equipment where the suitability of combination (that is, application or use) is determined by the CSA or the local inspection office having jurisdiction. 	<p>Pour satisfaire à la certification de la CSA dans des endroits dangereux, les informations suivantes font partie intégrante de la documentation des produits industriels de contrôle Allen-Bradley certifiés par la CSA.</p> <ul style="list-style-type: none"> • Cet équipement convient à l'utilisation dans des emplacements de Classe 1, Division 2, Groupes A, B, C, D, ou ne convient qu'à l'utilisation dans des endroits non dangereux. • Les produits portant le marquage approprié de la CSA (c'est à dire, Classe 1, Division 2, Groupes A, B, C, D) sont certifiés à l'utilisation pour d'autres équipements où la convenance de combinaison (application ou utilisation) est déterminée par la CSA ou le bureau local d'inspection qualifié.
<p>Important: Due to the modular nature of a PLC® control system, the product with the highest temperature rating determines the overall temperature code rating of a PLC control system in a Class I, Division 2 location. The temperature code rating is marked on the product label as shown.</p>	<p>Important: Par suite de la nature modulaire du système de contrôle PLC®, le produit ayant le taux le plus élevé de température détermine le taux d'ensemble du code de température du système de contrôle d'un PLC dans un emplacement de Classe 1, Division 2. Le taux du code de température est indiqué sur l'étiquette du produit.</p>
<p>Temperature code rating</p> 	<p>Taux du code de température</p> 
<p>The following warnings apply to products having CSA certification for use in hazardous locations.</p>	<p>Les avertissements suivants s'appliquent aux produits ayant la certification CSA pour leur utilisation dans des emplacements dangereux.</p>
 <p>ATTENTION: Explosion hazard —</p> <ul style="list-style-type: none"> • Substitution of components may impair suitability for Class I, Division 2. • Do not replace components unless power has been switched off or the area is known to be non-hazardous. • Do not disconnect equipment unless power has been switched off or the area is known to be non-hazardous. • Do not disconnect connectors unless power has been switched off or the area is known to be non-hazardous. Secure any user-supplied connectors that mate to external circuits on an Allen-Bradley product using screws, sliding latches, threaded connectors, or other means such that any connection can withstand a 15 Newton (3.4 lb.) separating force applied for a minimum of one minute. 	 <p>AVERTISSEMENT: Risque d'explosion —</p> <ul style="list-style-type: none"> • La substitution de composants peut rendre ce matériel inacceptable pour les emplacements de Classe I, Division 2. • Couper le courant ou s'assurer que l'emplacement est désigné non dangereux avant de remplacer les composants. • Avant de débrancher l'équipement, couper le courant ou s'assurer que l'emplacement est désigné non dangereux. • Avant de débrancher les connecteurs, couper le courant ou s'assurer que l'emplacement est reconnu non dangereux. Attacher tous connecteurs fournis par l'utilisateur et reliés aux circuits externes d'un appareil Allen-Bradley à l'aide de vis, loquets coulissants, connecteurs filetés ou autres moyens permettant aux connexions de résister à une force de séparation de 15 newtons (3,4 lb. - 1,5 kg) appliquée pendant au moins une minute.

Le sigle CSA est la marque déposée de l'Association des Standards pour le Canada.

PLC est une marque déposée de Allen-Bradley Company, Inc.

CSA logo is a registered trademark of the Canadian Standards Association

PLC is a registered trademark of Allen-Bradley Company, Inc.

Specifications

Outputs per Module	16 isolated
Module Location	1771-A1B thru -A4B I/O Chassis
Voltage Rating	74 to 138V ac, 47-63Hz
Current Rating (per channel)	5mA-2A continuous (max) 20A peak surge for 100ms; repeatable every 2 seconds 8A continuous per module (maximum)
Power Rating	3 Watts per output (max) @ 2A
On-state Voltage Drop (each output)	5.8V rms (max.) @ load current <50mA 1.5V rms (max.) @ load current >50mA
Off-state Leakage Current	3.0mA max. @ 138V ac
Signal Delay Times Off to On On to Off	8.3ms @ 60Hz max; 10ms @ 50Hz max 8.3ms @ 60Hz max; 10ms @ 50Hz max (zero cross switching)
Power Dissipation	13.25 Watts (max); 1.25 Watts (min)
Thermal Dissipation	45.2 BTU/hr (max); 4.3 BTU/hr (min)
Backplane Current	250mA maximum
Isolation Voltage	Tested at 2500V dc for 1 second per UL508 & CSA C22.2 #142
Maximum Cable Length	1000 ft (304.8 m)
Conductors Wire Size Category	14 gauge (2mm ²) stranded maximum 3/64 inch (2mm) insulation maximum 1 ¹
Environmental Conditions Operational Temperature Storage Temperature Relative Humidity	0° to 60°C (32° to 140°F) -40° to 85°C (-40° to 185°F) 5 to 95% (without condensation)
Keying	Between 22 and 24 Between 34 and 36
Field Wiring Arm	Catalog Number 1771-WN
Wiring Arm Screw Torque	7-9 inch-pounds
Fuses	3A 2AG Slo-Blo fuses (1 per output), Littelfuse P/N 229003 (Optional Fuse Kit, Cat. No. 1771-FE contains 5 fuses)
Agency Certification (when product or packaging is marked)	<ul style="list-style-type: none"> • CSA certified • CSA Class I, Division 2, Groups A, B, C, D certified • UL listed • CE marked for all applicable directives

¹ Refer to publication 1770-4.1, Programmable Controller Wiring and Grounding Guidelines



Allen-Bradley, a Rockwell Automation Business, has been helping its customers improve productivity and quality for more than 90 years. We design, manufacture and support a broad range of automation products worldwide. They include logic processors, power and motion control devices, operator interfaces, sensors and a variety of software. Rockwell is one of the world's leading technology companies.



Worldwide representation.

Argentina • Australia • Austria • Bahrain • Belgium • Brazil • Bulgaria • Canada • Chile • China, PRC • Colombia • Costa Rica • Croatia • Cyprus • Czech Republic • Denmark • Ecuador • Egypt • El Salvador • Finland • France • Germany • Greece • Guatemala • Honduras • Hong Kong • Hungary • Iceland • India • Indonesia • Ireland • Israel • Italy • Jamaica • Japan • Jordan • Korea • Kuwait • Lebanon • Malaysia • Mexico • Netherlands • New Zealand • Norway • Pakistan • Peru • Philippines • Poland • Portugal • Puerto Rico • Qatar • Romania • Russia-CIS • Saudi Arabia • Singapore • Slovakia • Slovenia • South Africa, Republic • Spain • Sweden • Switzerland • Taiwan • Thailand • Turkey • United Arab Emirates • United Kingdom • United States • Uruguay • Venezuela • Yugoslavia

Allen-Bradley Headquarters, 1201 South Second Street, Milwaukee, WI 53204 USA, Tel: (1) 414 382-2000 Fax: (1) 414 382-4444