

# Andover Continuum

## I/O System Reference



© 2010, Schneider Electric  
All Rights Reserved

No part of this publication may be reproduced, read or stored in a retrieval system, or transmitted, in any form or by any means, electronic, mechanical, photocopying, recording, or otherwise, without prior written permission of Schneider Electric.

This document is produced in the United States of America.

Infinity is a trademark of Schneider Electric. All other trademarks are the property of their respective owners.

*Andover Continuum I/O System Reference*

Rev. K

April, 2010

Schneider Electric part number: 30-3001-499

This manual (Rev. K) corresponds to the following firmware versions:

<b>IOU Modules</b>	<b>Version Released</b>
AC-1	23
AC-1 Plus	25
AO-4, DO-6, DI-6, DI-8, DM-20, LB-8, LC-1, LS-8, MI-6	10
DO-4	11
LO-2	11
UI-8	12
VS-8/VS-8T	11
VT-1	21

Related Documents:

*Andover Continuum Power Supply Reference, 30-3001-702*

*Andover Continuum NetController II Operation & Technical Reference, 30-3001-995*

*Andover Continuum Enclosure and Display Module Reference, 30-3001-711*

*Andover Continuum I/O System Installation Sheet, 30-3001-716*

The information in this document is furnished for informational purposes only, is subject to change without notice, and should not be construed as a commitment by Schneider Electric. Schneider Electric assumes no liability for any errors or inaccuracies that may appear in this document.

On October 1<sup>st</sup> 2009, TAC became the Buildings Business of its parent company Schneider Electric. This document reflects the visual identity of Schneider Electric. However, there remain references to TAC as a corporate brand throughout the Andover Continuum software. In those instances, the documentation still refers to TAC - only to portray the user interface accurately. As the software is updated, these documentation references will be changed to reflect appropriate brand and software changes. All brand names, trademarks, and registered marks are the property of their respective owners.

### **Schneider Electric**

One High Street

North Andover, MA 01845

(978) 975-9600

Fax: (978) 975-9782

<http://www.schneider-electric.com/buildings>

ii *Schneider Electric*

# Regulatory Notices

## Radio Interference – Federal Communications Commission

This equipment has been tested, and it complies with the limits for a Class A digital device, pursuant to Part 15 of the FCC Rules. These limits are designed to provide reasonable protection against harmful interference when the equipment is operated in a commercial environment. This equipment generates, uses, and can radiate radio frequency energy and, if not installed and used in accordance with the instructions in this manual, may cause harmful interference to radio communications. Operation of this equipment in a residential area is likely to cause harmful interference, in which case you will be required to correct the interference at your own expense.

## Radio Interference – Canadian Department of Communications

This digital apparatus does not exceed the Class A limits for radio noise emissions from digital apparatus set out in the Radio Interference Regulations of the Canadian Department of Communications.

## Brouillage Radioélectrique – Ministère des Communications du Canada

Le présent appareil numérique n'émet pas de bruits radioélectriques dépassant les limites applicables aux appareils numériques de la Classe A prescrites dans le Règlement sur le brouillage radioélectrique édicté par le ministère des Communications du Canada.

## CE – Compliance to European Union (EU)



This equipment complies with the European Union (EU) standards specified in the EU EMC directive 89/336/EEC and/or the product-safety low voltage directive 73/23/EEC, governing the European community.

## C-Tick – Australian Communications Authority (ACA)



This equipment carries the C-Tick label and complies with EMC and radio communications regulations of the Australian Communications Authority (ACA), N1831 governing the Australian and New Zealand communities.

## WEEE – Directive of the European Union (EU)



This equipment and its packaging carry the waste electrical and electronic equipment (WEEE) label, in compliance with European Union (EU) Directive 2002/96/EC, governing the disposal and recycling of electrical and electronic equipment in the European community.

# Contents

<b>Introduction</b> .....	<b>1</b>
<b>Mechanical Installation</b> .....	<b>4</b>
Overall Dimensions.....	7
Enclosure-Mounted Modules .....	8
I/O Module Layout Convention .....	9
<b>CPU-I/O Connections</b> .....	<b>10</b>
Connection of I/O Modules.....	11
Maximum Number of I/O Modules .....	12
Calculating Additional Power Supply Requirements .....	13
Maximum Length of I/O Bus .....	13
Cable Recommendations .....	13
Power Wiring Guideline Table .....	15
Connecting Remote I/O Modules with ACC-LON (RS-485) .....	16
Connecting Remote I/O Modules with LON FTT-10A .....	20
<b>Replacing or Adding I/O Modules</b> .....	<b>26</b>
<b>Module Configuration</b> .....	<b>27</b>
<b>Individual Module Wiring</b> .....	<b>32</b>
General Wiring Concerns for All Modules .....	32
Grounding the Modules .....	32
ESD Warning.....	33
<b>INPUT Modules</b>	
UI-8-10 / UI-8-10-10V.....	35
DI-6-AC / DI-6-AC-HV.....	53
DI-8.....	60
MI-6 .....	69
<b>OUTPUT Modules</b>	
DM-20.....	76
AO-4-8 / AO-4-8-O.....	86
DO-4-R / DO-4-R-O.....	95
DO-6-TR.....	103
LO-2 / LO-2-O .....	111
<b>MIXED Modules</b>	
DIO-20.....	123
AC-1 .....	129
AC-1A.....	148
AC-1 Plus .....	167
VS-8-4 / VS-8-4-T.....	193
VT-1 .....	199

# ANDOVER CONTINUUM

## I/O Systems

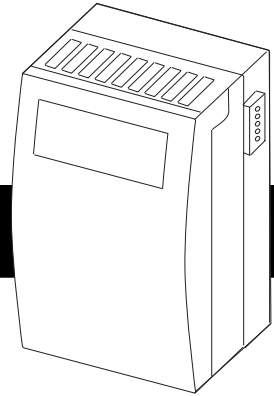

*This manual describes the installation, care and use of all Andover Continuum I/O modules.*

The *Andover Continuum* Ethernet-based intelligent building system allows you to mix and match various combinations of DIN rail-mounted modules—high density I/O, CPU and power supply, and your choice of several user interface modules—in a *single* controller location to meet your building's control and monitoring needs. With the *Andover Continuum* system, as your network grows, simply add or replace I/O modules as needed.

The *Andover Continuum* I/O modules feature a casing designed for natural convection cooling, and a 3-position front cover for easy, hands-free access. Built-in quick-release fasteners at the back of each I/O module are provided for DIN rail mounting—no tools required. These fasteners also snap into a locked position for panel mounting. Input and output connectors are located at the bottom of each I/O module and are removable for easy field access and maintenance. All *Andover Continuum* modules are designed for mounting in an optional NEMA 1-style *Andover Continuum* enclosure.

The *Andover Continuum* I/O modules communicate with the *Andover Continuum* NetController and NetController II CPU modules. (This manual uses the generic name, NetController for both series of CPU modules.) Like all *Andover Continuum* modules, the I/O modules snap together directly via built-in connectors on either side; so network expansion is quick and easy. Both power transmission and communication signals between the power supply module, NetController CPU module, and all I/O modules feed through this connection. For added convenience in certain applications, such as door control or lighting control, a single module or groups of I/O modules can be remotely located and connected using approved cable and powered from a local power supply. Each I/O module features its own push-button for quick and easy network commissioning.

**This document covers the standard Input and Output modules. For information regarding the special Andover Continuum enclosure door-mounted display modules consult the *Andover Continuum Enclosure and Display Module Reference*.**

# I/O System Introduction

The Andover Continuum I/O system comprises a series of modules separated by function that connect via a common electrical communications network. Each functional component (module) is enclosed in a plastic case containing all of its connections to the outside world. Modules are connected to a central controller via a standard five-conductor connector.

The Andover Continuum system includes at least one power supply and a single CPU module. I/O modules provide the controller with the ability to interface with the outside world. They connect directly and communicate with the CPU. The following is a typical architecture drawing of an Andover Continuum System:

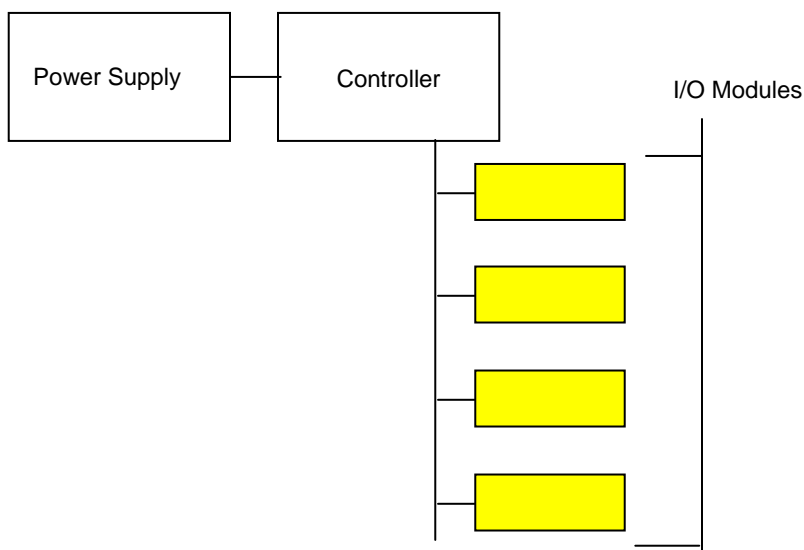

Andover Continuum I/O modules included in this document are INPUT, OUTPUT and MIXED. Display modules are covered in the *Andover Continuum Enclosure & Display Module Reference* 30-3001-711.

The **INPUT** modules available are:

- UI-8-10; Universal Input Module \* † \*\*
- UI-8-10-10V; Universal Input Module \* † \*\*
- DI-6-AC; AC Digital Input Module (12-120V)
- DI-6-AC-HV; AC Digital Input Module (120/240V)
- DI-8; Digital Input Module \* †
- DM-20; Digital Input/Output Module \* †
- MI-6; MilliAmp Input Module \*

The **OUTPUT** modules available are:

- AO-4-8; Analog Output Module \*
- AO-4-8-O; Analog Output Module (with override) \*
- DO-4-R; Relay Output Module \* † \*\*
- DO-4-R-O; Relay Output Module (with override) \* † \*\*
- DO-4A-R; Relay Output Module \*
- DO-4A-R-O; Relay Output Module (with override) \*
- DO-6-TR; Triac Output Module
- LO-2; Lighting Output Module
- LO-2-O; Lighting Output Module (with override)

The **MIXED** modules available are:

- DIO-20; Input/Output Module
- AC-1; Door, Access Control, Wiegand Module † \*\*
- AC-1A; Door, Access Control, Wiegand Module † \*\*
- AC-1 Plus; Door, Access Control, Wiegand/ABA/Ck34 Module † \*\*
- VS-8-4; Video Switch Module †
- VS-8-4-T; Video Switch with Titling Module †
- VT-1; Voice Telecom Module

\* These modules are also listed for smoke control applications. The model number for a smoke control listed part includes an '-S' suffix.

† These modules are listed for UL 294 Access Control Applications. See also: *Andover Continuum UL 294 Access Control Systems Reference*, 30-3001-746.

(\*\*) These modules are listed for UL 1076 Applications. See also: *Andover Continuum UL 1076 Burglar Alarm Systems Reference*, 30-3001-800.

# Mechanical Installation

Each I/O module, except the Display variety, is enclosed in a plastic case that is designed to be mounted on a standard DIN rail or fastened to a panel.

**Note:** *In order to meet agency requirements in the United States, it is necessary that the modules along with the power supply and CPU be housed in another metal enclosure i.e., a NEMA box or the Andover Continuum enclosure. Only Schneider Electric enclosure models ENC-0DISP and ENC-3DISP are approved for UL 294 Access Control Systems.*

The two types of I/O module plastic cases are illustrated below:

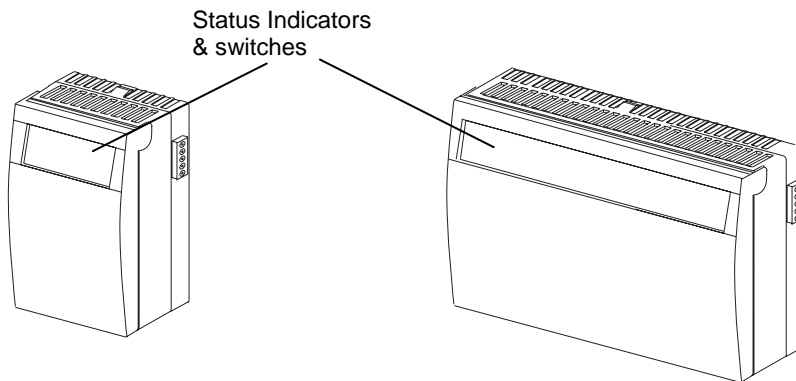

Status indicators and operator switches are located on the indicator panel. Other switches available for module configuration may be accessed by lifting the hinged door of the smaller module.

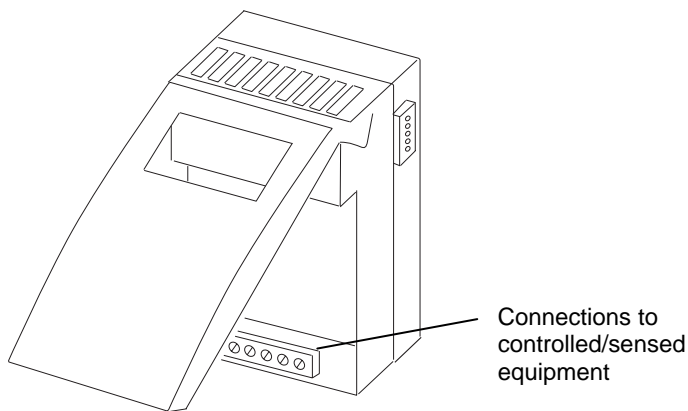



On the back of each module are molded DIN rail guide fingers. The design allows the module to easily hook onto and slide along a standard DIN rail. The fingers also allow the module to be mounted directly to a panel using them as a bracket. A stand-off is molded into the locking finger. To mount the module on a panel, extend the locking fingers and insert screws through the standoffs as shown below:

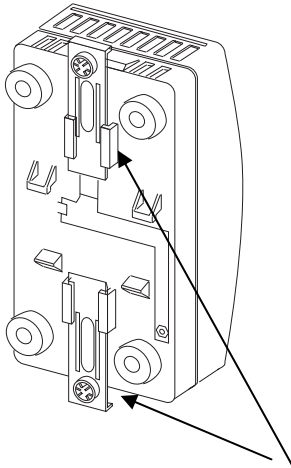

Locking Fingers

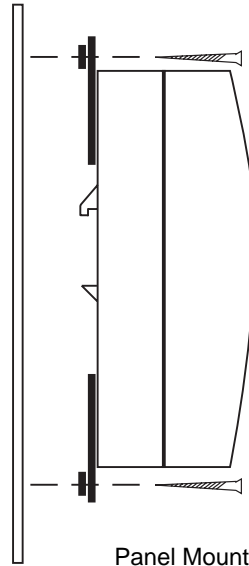

Panel Mounting

DIN Rail Mounting: With the mounting brackets (locking fingers) extended outward, hook the module onto the DIN rail as shown below:

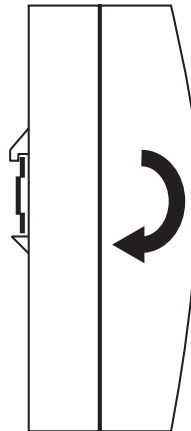
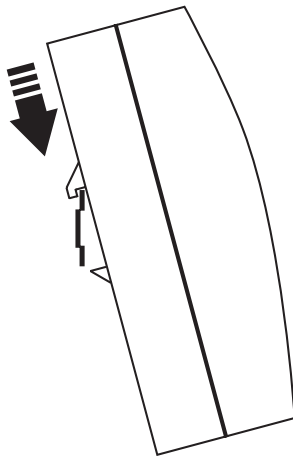

Slide the module into position.

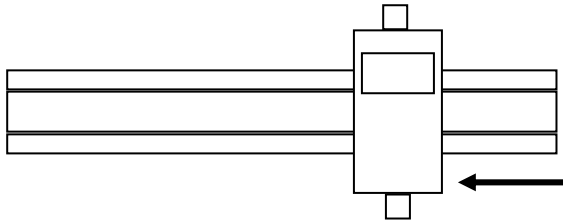

Press the upper bracket into its locked position.

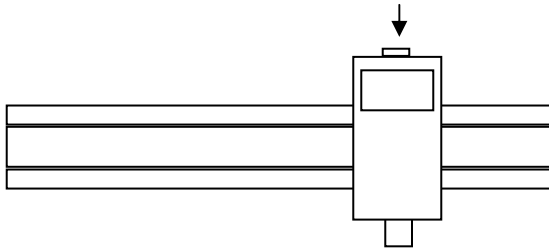

Press the lower mounting bracket(s) inward until it locks the module in place.

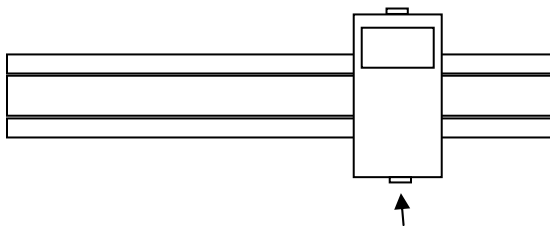

## Grounding the Modules

All I/O modules except the VS-8 include a metal clip that is built into the locking mechanism on the back of the case. Mounting the module on an electrically conductive metal surface or DIN rail automatically provides an Earth ground. The VS-8 includes a ground stud that must be connected to Earth ground. It is important that this connection be made as close to the module as possible.

**Note: Anodized Aluminum DIN rails are not electrically conductive.**

# Overall Dimensions

The overall dimensions of the two types of I/O cases are as shown:

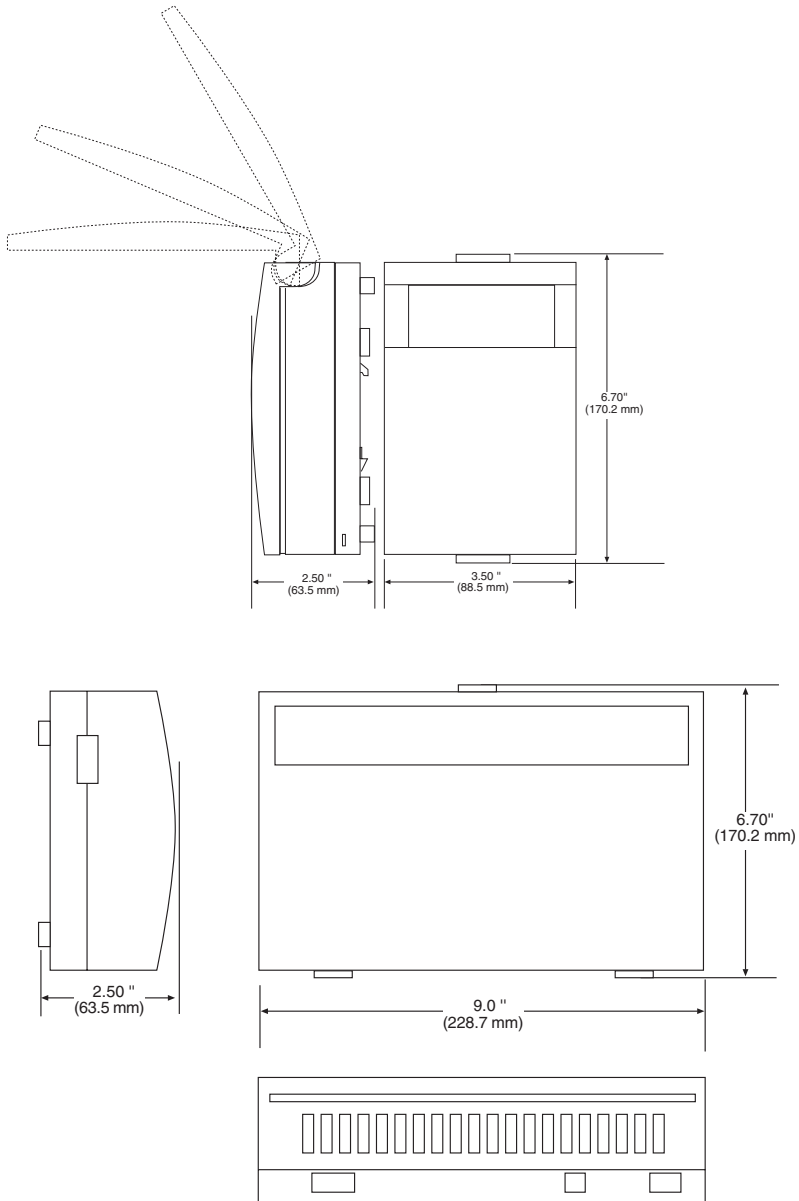

## Enclosure-Mounted Modules

The Schneider Electric enclosure provides a place to mount a power supply, CPU and up to 10 DIN rail mounted I/O modules. Several display modules can be affixed to the front panel.

The Display modules are designed to fit into openings left by removing panels in the front door.

The enclosure is a 6" deep NEMA box with integral display panels, DIN rails, cable troughs and a battery storage compartment.

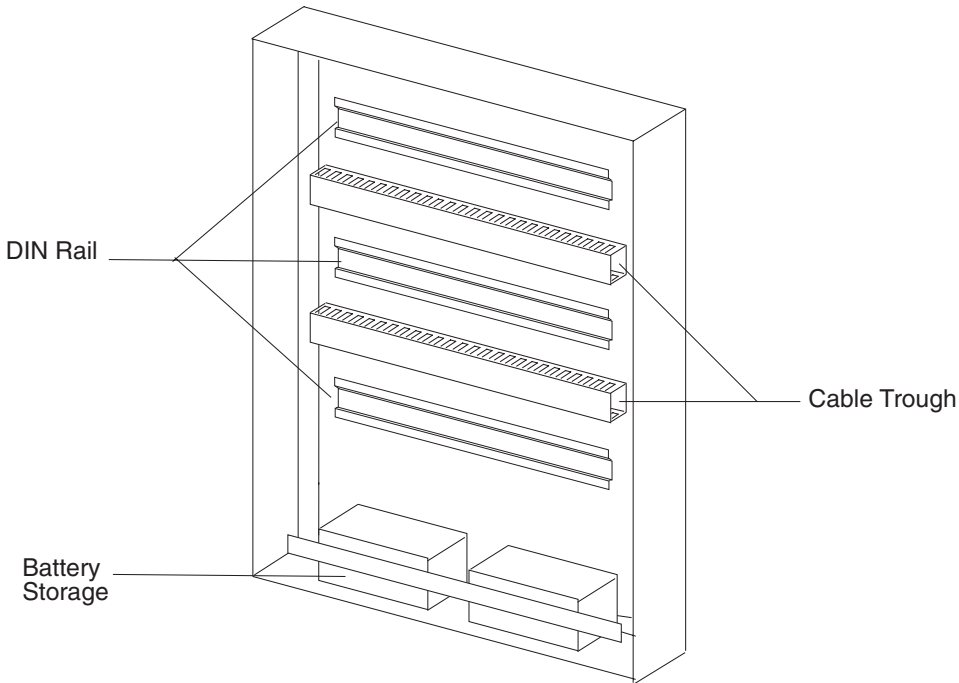

The enclosure features three DIN rails and cable management accessories. Use of the new enclosure is not required; however, it provides a convenient method of constructing small local systems.

The front door of the enclosure contains removable sections into which special operator display and control modules may be mounted. Alternately, Plexiglas panels may be used to view the status lights of all internal modules when the door is closed.

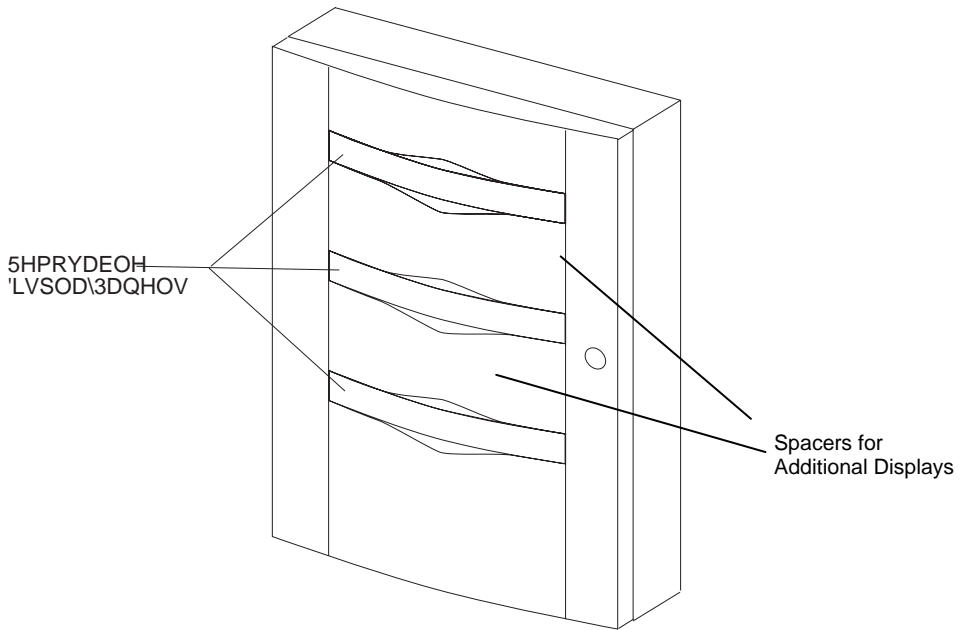

## I/O Module Layout Convention

By convention, I/O modules should be separated according to function and whether they are connected to low or high voltages.

Typically, Input wires should enter from only one of the wiring troughs, and should come from the left side of the rack.

Output wires should enter from the other wiring trough, and should come from the right side of the rack.

A good system would be to install all your input modules on one DIN rail, output modules on the next rail, and so on.

# CPU-I/O Connections

The Andover Continuum NetController/NetController II CPU module includes a connector on the upper right side of its case for further distribution of the 24 VDC input power and special I/O communications signals to all I/O modules. Andover Continuum I/O modules use these signals for power and communications.

The power-I/O connector is a five pin male assembly that is designed to easily insert directly into the left side connector of any I/O module. The signals within this connector are as follows:

<b>PIN</b>	<b>Function</b>
5	+24 VDC
4	24 VDC Return
3	Shield
2	Comm B
1	Comm A

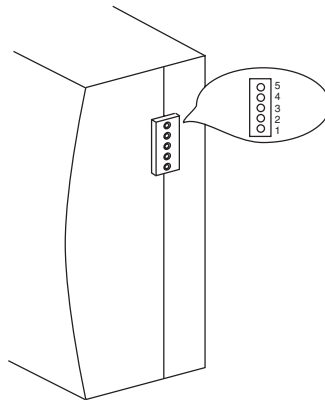

The main system power supply generates a +24 VDC source for the CPU. This power source is received through the input power connector on the left side of the CPU module and sent through to pins 4 and 5 of this connector.

All Andover Continuum I/O modules can operate at 24V. Some have extended ranges to allow operation at lower voltages. Refer to the individual specifications for each module.

Communications between the CPU and I/O modules is through a two-signal serial interface that is factory configured as either RS 485 ACC-LON or LON FTT-10A.

Pins 1 and 2 (Comm B and Comm A) provide the electrical connection for this interface. Pin 3 (Shield) is the communications signal shield connection. This is not an Earth ground connection. Proper shielding requires that the installer connect all shields together. The CPU (if grounded properly) provides the single Earth ground point for all modules. Each I/O also has its own Earth ground connection.

# Connection of I/O Modules

When installing I/O modules it is **imperative** that the installer supply a solid Earth ground connection to the pins provided.

The CPU can directly connect to I/O without the use of cables through a system of built-in plugs and jacks. All I/O modules include two complementary module inter-connectors.

Creating a system is as simple as physically plugging the modules together.

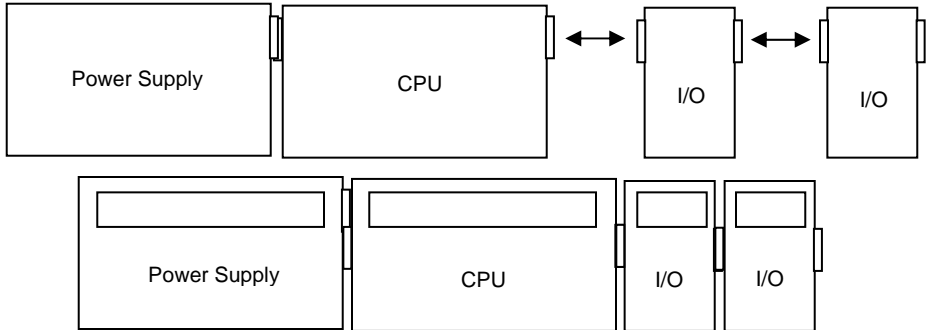

In vertical extended systems, I/O modules may be located above or below other modules. In this case, cable assemblies bridge the I/O modules together.

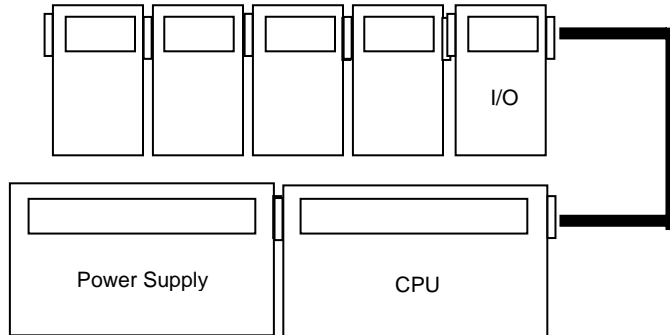

The cables necessary to connect the CPU and external I/O modules are attached using a plug-in screw terminal connector. Connection between the modules is one-to-one straightforward wiring as shown below:

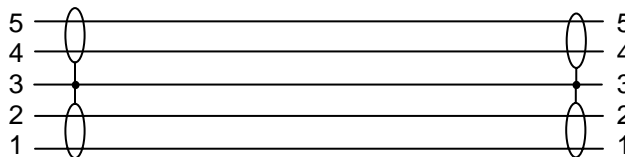

Connectors are available from Schneider Electric under part number 01-0010-840.

## Maximum Number of I/O Modules

The Andover Continuum system allows a maximum of 32 I/O modules per CPU. There is also a limit based upon the capacity of the power supply feeding the modules.

**Note:** It is possible to insert auxiliary power supplies into the I/O bus to increase the number of modules supported, up to a maximum of 32. The *Andover Continuum Power Supply Reference*, 30-3001-702, includes information on auxiliary supply installation.

- PS 120/240 AC 50 U, UPS power supply: 35 Watts of power available
- PS 120/240 AC 85 U, UPS power supply: 70 Watts of power available
- PS 120/240 AC 50, non-UPS power supply: 50 Watts of power available
- PS 120/240 AC 85, non-UPS power supply: 85 Watts of power available
- PS -48 DC 50, Battery operated power supply: 50 Watts of power available

UPS power supplies (models with the designation 'U') include battery charging circuitry that consumes 15 Watts of the total power available. This is why the UPS supplies are listed with less available Wattage.

To determine the maximum number of I/O modules each power supply can support, subtract the power requirements for each module from the maximum available per supply.

If the supply also powers a NetController, be sure to subtract the 10 Watts it consumes.

The power requirements for the NetController and each I/O module\* is listed below:

Module	Power @24.0 VDC	
	(Watts)	(mA)
NetController	10	417
UI-8-10 & UI-8-10-10V; Universal Input Modules	0.7	29
DI-6 AC & DI-6 AC HV; AC Digital Input Modules	0.7	29
DI-8; Digital Input Module	0.8	33
MI-6; MilliAmp Input Module	3.8	158
DM-20; Digital Input/Output Module	0.5 **	20 **
AO-4-8 & AO-4-8-O; Analog Output Modules	3.8	158
DO-4(A)-R & DO-4(A)-R-O; Relay Output Modules	2.8	116
DO-6-TR; Triac Output Module	1.1	45
LO-2 & LO-2-O; Lighting Output Modules	0.4	16
AC-1; Door, Access Control, Module	2.6 **	108
AC-1A; Door, Access Control, Module	2.0 **	83
AC-1 Plus; Door, Access Control, Module	2.2 **	92
VS-8 & VS-8-T; Video Switch Module	2.0	83
VT-1; Voice Telecom Module	1.5	63

\* Power requirements for Display Modules can be found in the *Andover Continuum Enclosure and Display Module Reference*, 30-3001-711.

\*\* Listed power value does not include any devices attached and powered by the module (card readers or DIO-20). Refer to the formulas on the next page for calculation.



## Calculating Additional Power Supply Requirements

The DM-20 and all the AC Series access control modules have the built-in capability to power an external device. The module power requirements listed in the table on the previous page does not include power consumption information for these devices. In the case of external card readers and keypads, it is not possible for us to determine the power requirements of all the combinations of manufacturer's products you might connect. However, we can provide a simple formula to determine any additional power the module may draw when powering those devices.

<b>Module</b>	<b>Formula</b>	<b>Example</b>
AC-1:	15 X (Reader/Keypad Current Amps)	15 X 0.05 (50 mA reader) = .75W
AC-1A:		
AC-1Plus:	Module X Reader/Keypad Supply Voltage Current (Amps)	24 X 0.05 (50 mA reader) = 1.20W
DM-20	Refer to the DIO-20 section of this document for additional power requirements	

## Maximum Length of I/O Bus

The Andover Continuum I/O Bus is a network. Networks are limited by cable lengths because electrical signals lose power and distort as they travel along wire. The longer the wire, the lower the signal strength. The following are the maximum cable length specifications:

RS-485	2000 ft. (610 m)
FTT-10A	8858 ft. (2700 m) double termination 1640 ft. (500 m) free topology

## Cable Recommendations

### *Data Cable (Pins 1, 2 and 3)*

You must use shielded cable for the data lines (pins 1, 2 and 3) to provide reliable communications and to ensure compliance with the Class A FCC limits (USA).

#### **ACC-LON (RS-485)**

The data cable should be 24-gauge (0.25 mm), single-twisted-pair, tinned, shielded copper wire with an impedance of 100-120  $\Omega$ s and a nominal velocity of propagation of 78%.

Capacitance of the cable should be below 12.5 pF/ft (41 pF/m) between conductors and below 22 pF/ft (72 pF/m) between the conductor connected to ground and the next conductor.

The following cable meets all of the data cable specifications:

***Belden 9729, double twisted pair, shielded***

## LON FTT-10A

The installer can choose a variety of cables, depending on cost, availability, and performance. Performance can vary with cable type. The transmission specification depends on such factors as resistance, mutual capacitance, and the velocity of propagation. Currently, Schneider Electric has documented system performance on the cable types shown below. They are listed in order of performance.

<b>Cable Type</b>	<b>Wire dia./AWG</b>
Belden 85102, single twisted pair, stranded 19/29, unshielded	16
Belden 8471, single twisted pair, stranded 19/29, unshielded, 600C	16
Level IV, twisted pair, typically solid & unshielded	22
TIA568A Category 5, twisted pair	24

If a shielded cable is used, the shield should be connected to earth ground via a 470 k $\Omega$ , 1/4 W  $\leq$ 10%, metal film resistor to prevent static charge build-up.

### *Power Cable (Pins 4 and 5)*

You should use shielded cable for the power lines as well (pins 4 and 5) to ensure noise immunity and therefore more reliable operation. The shield would be connected to pin 3 like that of the data cable.

The gauge of the power cable is determined by the power it carries. As indicated previously, the longer the wire the more voltage drop. Do not allow the power supply voltage measured at the furthest remote module to drop more than the allowable amount:

24 VDC modules: 2V (1V for the power run and 1V for the return run)  
10-28 VDC modules: 12V (6V for the power run and 6V for the return run)

Voltage drop can be calculated by using Ohms Law:

$$\text{Voltage} = \text{Current} \times \text{Resistance}$$

A table providing some guidelines for choosing wire gauge is included on the next page.

## Power Wiring Guideline Table

The following is a conservative estimate of typical power consumptions and their related wire gauge and number of feet:

### 24 VDC Modules

		Total I/O Power Draw (Watts)				
		10	20	30	40	50
AWG	Resistance per 1000 ft (305 m)	Distance in Feet (meters)				
14	2.5	585 (178)	255 (78)	145 (44)	90 (27)	57 (17)
16	4	366 (111)	159 (48)	91 (28)	56 (17)	36 (11)
18	6	244 (74)	106 (32)	60 (18)	38 (12)	24 (7)
20	10	146 (44)	64 (20)	36 (11)	23 (7)	14 (4)
22	15	98 (30)	43 (13)	24 (7)	15 (6)	10 (3)
24	24	61 (19)	27 (8)	15 (5)	9 (3)	6 (2)

### 10 - 28 VDC Modules

		Total I/O Power Draw (Watts)				
		10	20	30	40	50
AWG	Resistance per 1000 ft (305 m)	Distance in Feet (meters)				
14	2.5	3885 (1184)	1905 (581)	1245 (379)	915 (279)	717 (219)
16	4	2428 (740)	1191 (363)	778 (237)	572 (174)	448 (137)
18	6	1619 (493)	794 (242)	519 (158)	381 (116)	299 (91)
20	10	971 (296)	476 (145)	311 (95)	229 (70)	179 (55)
22	15	648 (198)	318 (97)	208 (63)	153 (47)	120 (37)
24	24	405 (123)	198 (60)	130 (40)	95 (29)	75 (23)

These tables are intended as a guide. There is no way to account for every Andover Continuum I/O permutation. External noise suppression may be required if the power wiring is run in a noisy environment.

## Connecting Remote I/O Modules with ACC-LON (RS-485)

The Andover Continuum system allows I/O modules to be placed in a remote location from the CPU (NetController). Long cable lengths in ACC-LON (RS 485)-based networks can cause signal communications problems on the I/O bus.

When locating an I/O module remotely on an RS 485-based bus, it is necessary to add an external 120  $\Omega$  terminator resistor to the bus to compensate for the distance. The terminator must be connected at both ends of the bus for proper operation.

The following diagrams are typical installations that indicate the correct placement of the terminator:

### Simple CPU and 1 ACC-LON Remote I/O Module:

The I/O Bus that needs to be terminated is the one formed by the cable attaching the remote module to the CPU. In this case, a terminator resistor is connected across the communications lines (pins 1 & 2) directly at the NetController and again at the remote I/O module.

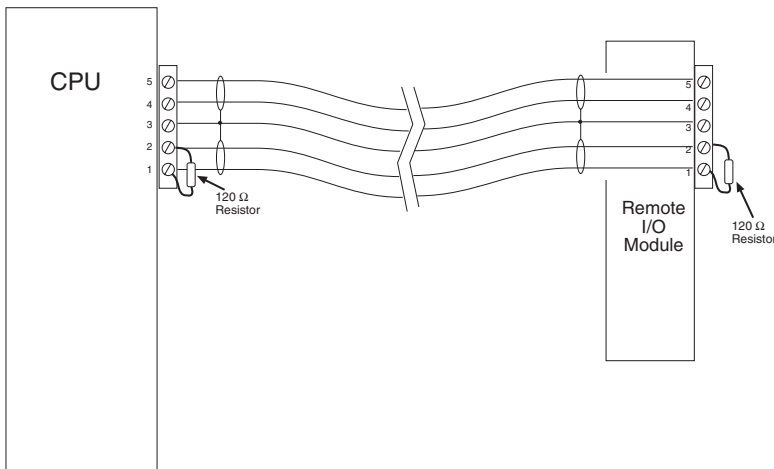

### **CPU with Local and 1 ACC-LON Remote I/O Module:**

The I/O Bus that needs to be terminated is the one formed by the cable that starts at the NetController and ends at the remote module. The bus that extends from the NetController through the local I/O stack does not need termination. In this case, the terminator resistor is connected directly across the communications lines (pins 1 & 2) at the NetController and again at the remote I/O module.

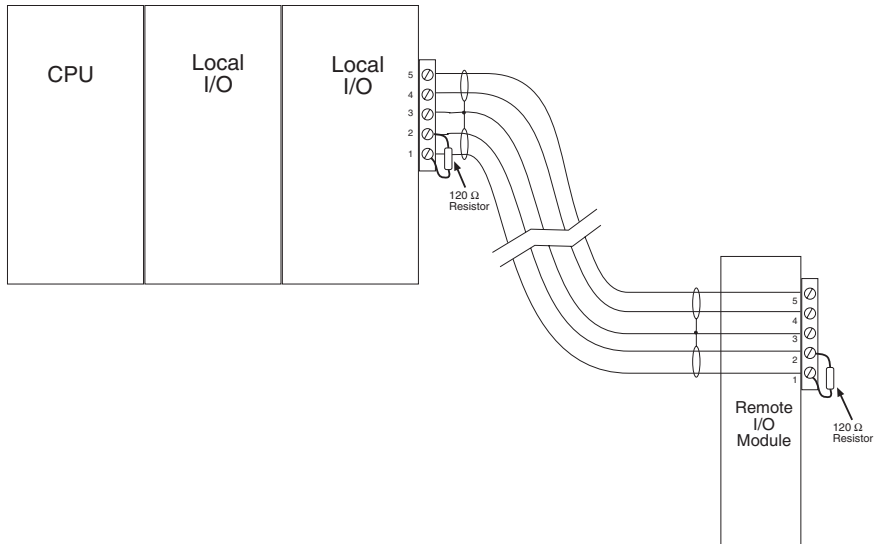

### **CPU with Local and Several Remote ACC-LON I/O Modules:**

The I/O Bus that needs to be terminated is the one formed by the cable that starts at the NetController and ends at the first remote module. The bus that extends from the NetController through the local I/O stack and the one that starts at the first remote module and extends through subsequent modules do not need termination. In this case, the terminator resistor is connected directly across the communications lines (pins 1 & 2) at the NetController and again at the first remote I/O module.

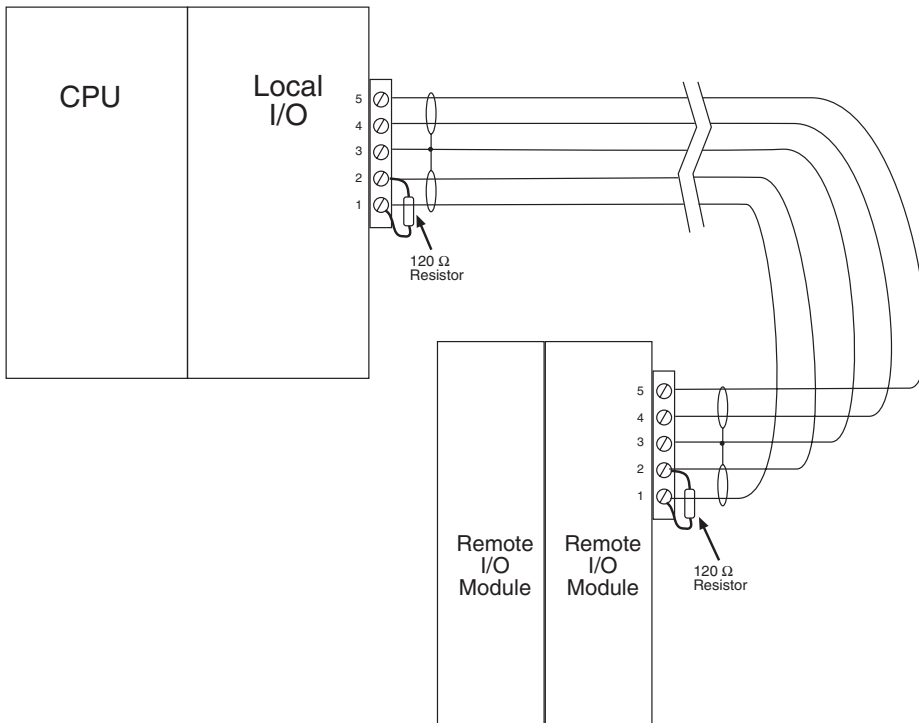

### **CPU with Two Remote ACC-LON Modules Separated by Distance:**

The I/O Bus that needs to be terminated is the one formed by both cables on either end of the first remote I/O module. In this case, the bus begins at the NetController, flows by the first remote module and ends at the second. The terminator resistor is connected directly across the communications lines (pins 1 & 2) at the NetController and again at the last remote I/O module. If the last module is actually a stack of directly connected I/O modules, the terminator is placed at the first module of the stack as indicated in the scenario described on the previous page.

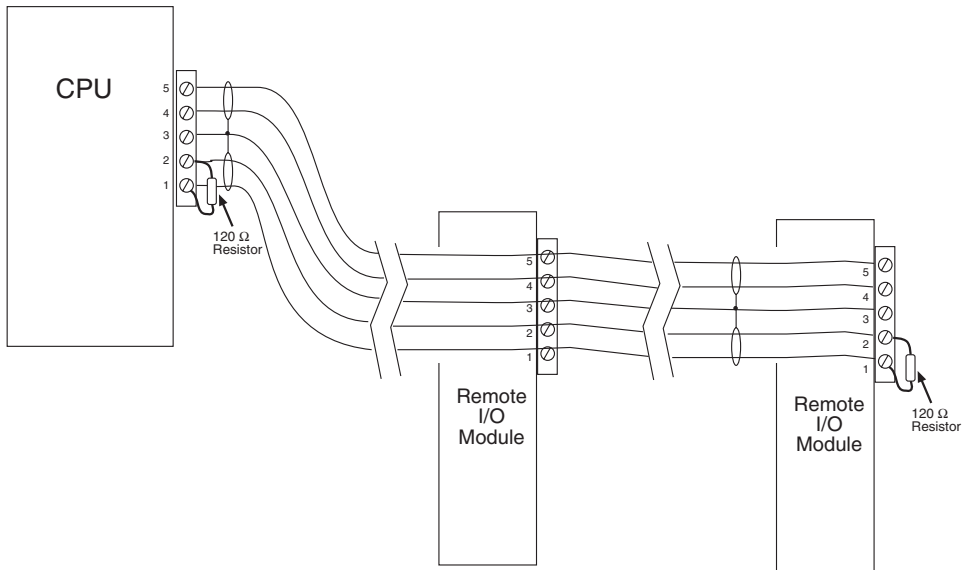

## Connecting Remote I/O Modules with LON FTT-10A

The ACC LON bus topology wiring (RS-485) consists of a network of I/O modules that are interconnected using a shielded twisted wire pair. In accordance with RS-485 guidelines, all of the devices must be wired in a bus topology to limit electrical reflections and ensure reliable communications. There is a high cost associated with installing and maintaining the cable plant that links together the many elements of an RS-485 based control system. Bus topology wiring is more time consuming and expensive to install because the installer is unable to branch or star the wiring where convenient: all devices must be connected directly to the main bus.

The best solution for reducing installation and maintenance costs and simplifying system modifications is a flexible topology communication system. Echelon's free topology transceiver (FTT) technology offers just such a solution, and provides an elegant and inexpensive method of interconnecting the different elements of a distributed control system.

The Echelon LON FTT-10A free topology architecture allows you to wire Andover Continuum I/O modules with virtually no topology restrictions.

Unlike ACC-LON, the FTT-10A system uses a free topology wiring scheme that supports star, loop, and/or bus wiring. This design has many advantages. First, the installer is free to select the method of wiring that best suits the installation, reducing the need for advanced planning and allowing last minute changes at the installation site. Second, retrofit installations with existing wiring plants can be accommodated with minimal, if any, rewiring. This capability ensures that FTT-10A technology can be adapted to both old and new projects. Finally, free topology permits Andover Continuum systems to be expanded in the future by simply tapping into the existing wiring where it is most convenient to do so. This reduces the time and expense of system expansion, and from the customer's perspective, keeps down the life cycle cost of the free topology network.

### **IMPORTANT FTT-10A NETWORK INSTALLATION NOTICE**

The termination and wiring information provided in this guide is a small subset of the complete technical information presented by Echelon Corporation in their FTT-10A installation documentation. It is highly recommended that you obtain their document and read the sections pertaining to network installation. As a courtesy, the Echelon FTT-10A documentation has been included on the TAC TSD website.

The document filename is **Echelon FTT-10A.pdf**



### FTT-10A Cable Termination (see important notice on the previous page)

When locating an I/O module remotely on a LON FTT-10A-based system, it is necessary to add an external terminator to the wiring to compensate for the distance. The terminator can be connected at both ends or at one central point.

**\* The Schneider Electric implementation of the Lon FTT-10A network can connect to a Link-Power network; however, it does not use the Link Power.**

### Free Topology Segment

In a free topology segment, only one termination is required and may be placed anywhere on the free topology segment. Using 24 AWG cable the maximum loop impedance is 75  $\Omega$ s.

#### Termination

##### Non-Link Power network

Resistor = 52.30 $\pm$ 1%, 1/8W

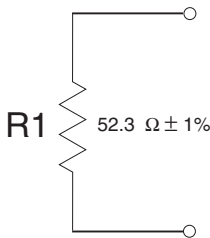

#### Termination

##### Link Power network

Resistor = 52.30 $\pm$ 1%, 1/8W

Capacitors = 100  $\mu$ F 50V min.

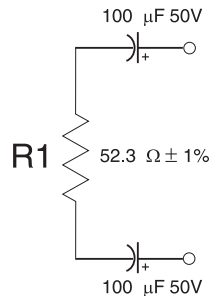

### Doubly Terminated Bus Topology Segment

In a doubly terminated bus topology, two terminations are required, one at each end of the bus. Using 24 AWG cable the maximum loop impedance is 150  $\Omega$ s.

#### Termination

##### Non-Link Power network

Resistor = 105  $\Omega$ ±1%, 1/8W

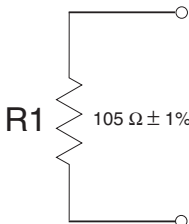

#### Termination

##### Link Power network

Resistor = 105  $\Omega$ ±1%, 1/8W

Capacitors = 100  $\mu$ F 50V min.

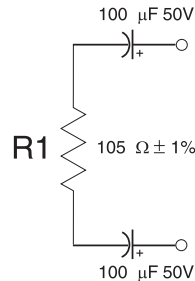

The following characteristics apply when using doubly terminated or free topology wiring schemes:

1. Network lengths vary for doubly terminated vs. free topology.
2. Network lengths vary based on cable type.
3. FTT-I/O has two specifications for a free topology network: total wire length and node-to-node wire length (which also applies to termination).

A doubly terminated bus may have stubs of up to 3 meters from a bus to each node.

### Doubly Terminated Bus Topology Specifications

	Maximum bus length (meters)
Belden 85102	2700
Belden 8471	2700
Level IV, 22AWG	1400
JY (St) Y 2x2x0.8	900
TIA Category 5	900

The free topology transmission specification includes two components that must be met for proper system operation. The distance from each transceiver to all other transceivers and to the termination (including the LPI-10 termination, if used) must not exceed the *maximum node-to-node distance*. If multiple paths exist, e.g., a loop topology, then the longest path should be used for calculations. The *maximum total wire length* is the total amount of wire connected per segment.

### Free Topology Specifications

	Maximum node-to-node distance (meters)	Maximum total wire length (meters)
Belden 85102	500	500
Belden 8471	400	500
Level IV, 22AWG	400	500
JY (St) Y 2x2x0.8	320	500
TIA Category 5	250	450

The following pages contain diagrams of typical installations that indicate the correct placement of the terminator:

**Example of Maximum Total and Node-to-Node Lengths**

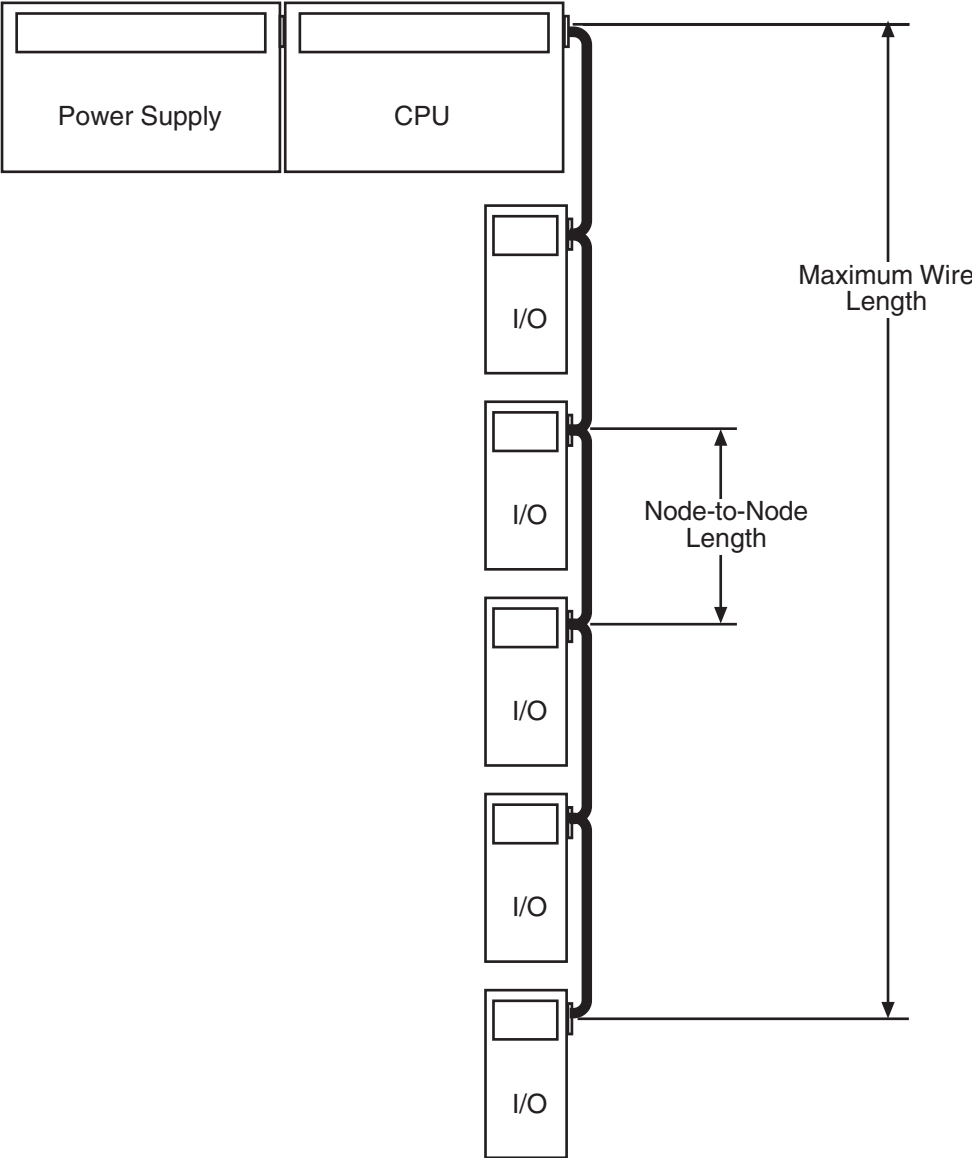

**CPU with Local and a CPU with Several Remote FTT-10A I/O Modules\*:**

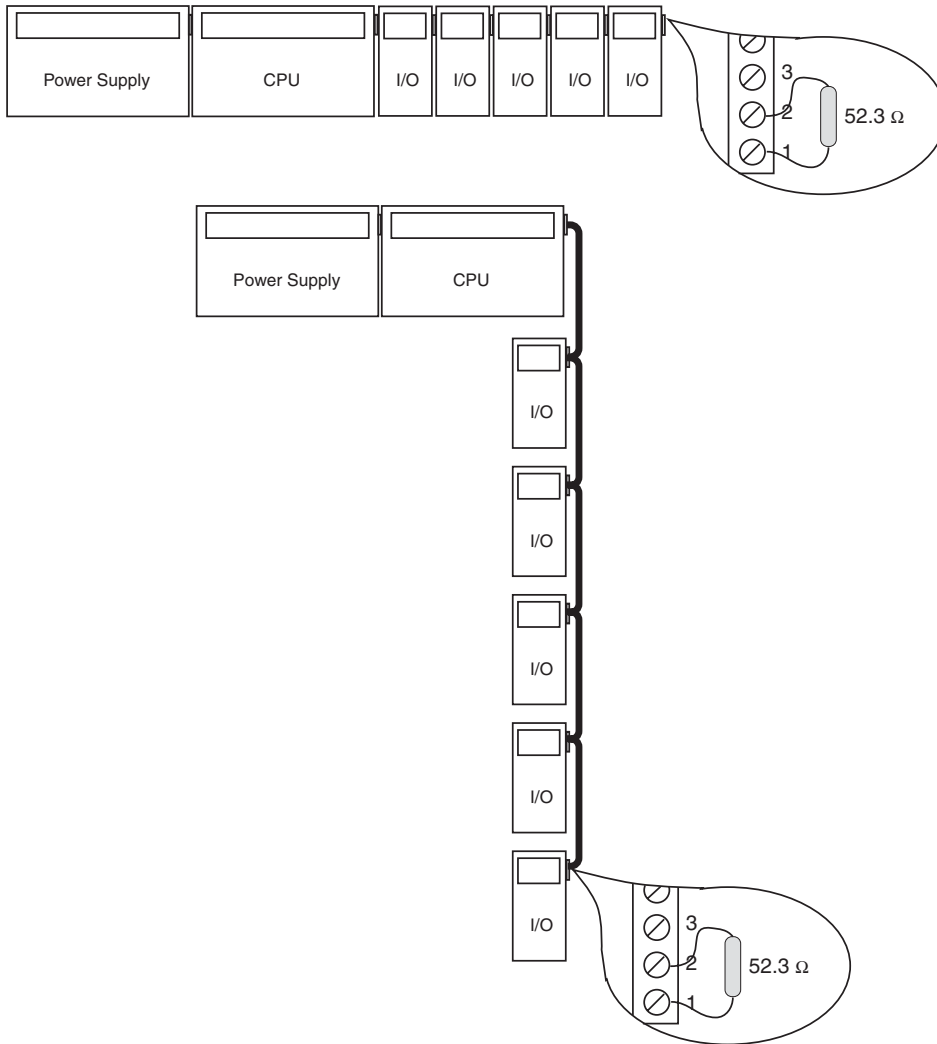

\* See Important Installation Notice on page 20

**CPU with Several Remote FTT-10A I/O Modules and Doubly Terminated Bus\*:**

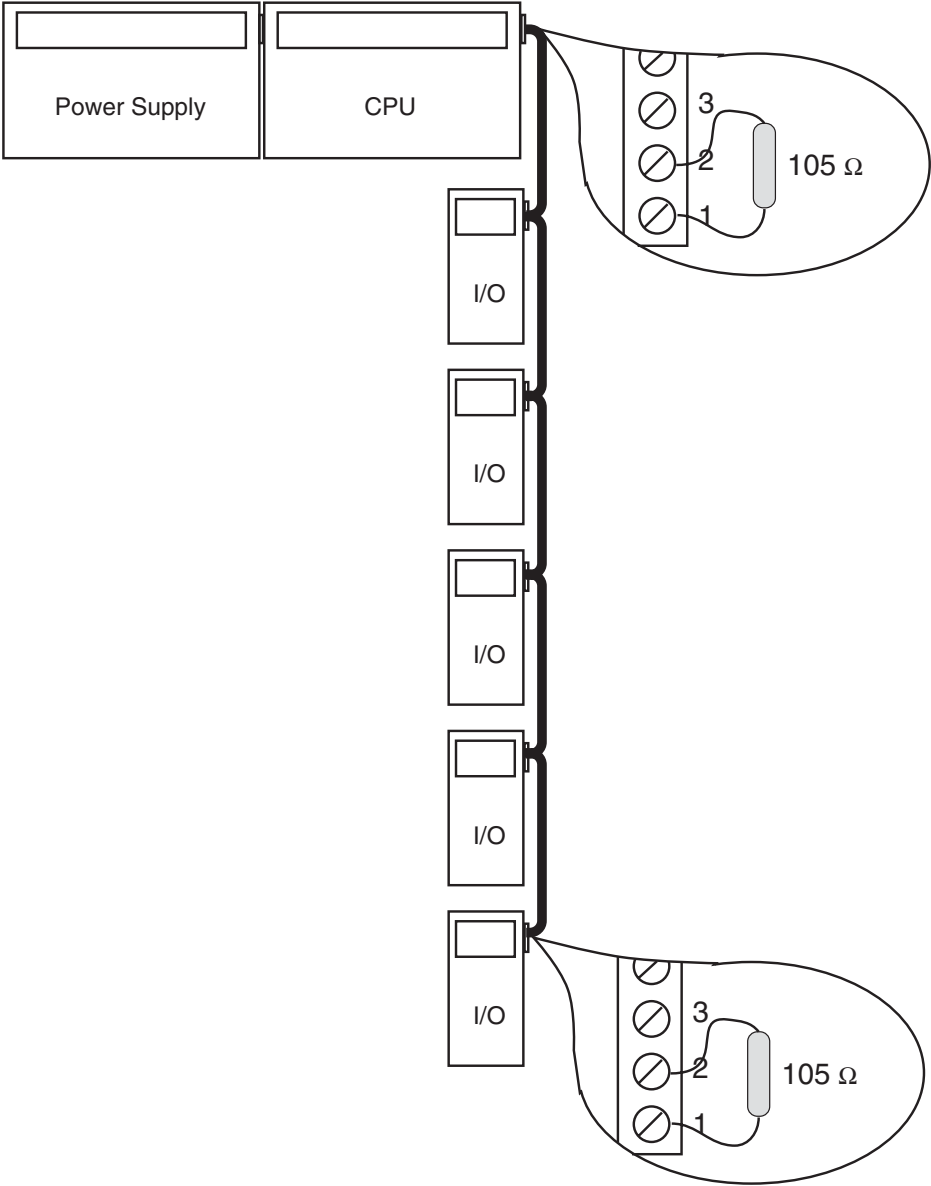

\* See Important Installation Notice on page 20

# Replacing or Adding I/O Modules

There are two ways to replace an I/O module to minimize the potential for long-term harm to any equipment. The procedure that you follow depends upon the exact installation and the circumstances that exist at the time of replacement. Both procedures are described below. In either case, the controlled equipment must be overridden during the process. If no external method of override exists, the equipment will go off.

## **Remove all power from the NetController and I/O modules:**

1. Turn power supply off.
2. Disconnect the batteries.
3. Replace or add the I/O module.
4. Turn power supply on.
5. Reconnect batteries.
6. Reload NetController

## **Remove power to the I/O bus only:**

1. Ensure that batteries are connected and fully charged.
2. Turn power supply off.
3. On the CyberStation workstation or Command Terminal Interface, cd to the appropriate controller in the command line: type "set IOUPower = off". The battery will now only power the CPU and modem (if applicable).
4. Replace or add the I/O module.
5. Restore power.
6. If the NetController version is prior to 1.03, type "set IOUPower = on" in the command line in CyberStation or Command Terminal Interface.

# Module Configuration

This section of the document describes the procedure of configuring each module so that it will be recognized by the Andover Continuum hardware. The following procedure is common to all modules. Follow these instructions in the order given to assure proper operation of the module.

It is assumed that you have knowledge or have access to someone who does have knowledge of the operation of the CyberStation workstation. It is also assumed that your CyberStation has configuration capabilities, is operating, logged-in and that the NetController connecting to the modules you are trying to configure has already been configured.

## Commissioning a New I/O Module - CyberStation

When you install a new I/O module onto the bus you must commission the unit before it will operate properly. Follow the steps below to properly commission an I/O module using the CyberStation workstation:

*Remove power from the I/O Bus where the module is to be installed*

- Step 1 On the I/O Bus: Connect the IOU Module**  
Connect the IOU Module to the I/O Bus.
- Step 2 On the I/O Bus: Restore Power**  
Restore power to the I/O Bus.
- Step 3 From CyberStation: Create the IOU Module**  
Log onto a CyberStation and create a new IOU module via the IOUModule editor.
- Step 4 From CyberStation: Assign an IOU number to the Module**  
During the creation process, you assign a unique number to the module being configured.
- Step 5 If the module is not easily accessible: Enter the module ID into the Module ID text field.**  
Enter the module ID found on the label inside the cover of the module into the field and click the **Apply** button, then skip to **Step 8**.
- Step 6 If the module is easily accessible: Click the Learn Button on CyberStation**  
After creating the module and assigning the number, click the Learn button. A dialog box displays requesting the operator to press the Commission button on the physical module.
- Step 7 On local Modules: Press the Commission button on the Module**  
Press the Commission button found on the front panel of the module. Clicking this button sends information from the module to CyberStation. When you push the Commission button, the dialog box should disappear indicating that it received the information from the module.

### **Step 8 On the CyberStation: Refresh the Form**

When you refresh the form you should notice that the ModuleID for commissioned modules, the ProgramID field and the IO model type (i.e. AO-4-8) are automatically entered. This information was received from the module. Also, the Comm Status should indicate an on-line status.

## **Commissioning a New I/O Module – Command Terminal**

When you install a new I/O module onto the bus you must commission the unit before it will operate properly. Follow the steps below to properly commission an I/O module using the Command Terminal:

***Remove power from the I/O Bus where the module is to be installed***

### **Step 1 On the I/O Bus: Connect the IOU Module**

Connect the IOU Module to the I/O Bus.

### **Step 2 On the I/O Bus: Restore Power**

Restore power to the I/O Bus.

### **Step 3 From the Command Terminal: Create the IOU Module**

Log onto a Command Terminal and create a new IOU Module (select Edit, then IOU Modules, then enter a name for the new IOU Module).

### **Step 4 On the Command Terminal: Assign an IOU number to the Module**

During the creation process, you assign a unique number to the module being configured.

### **Step 5 If the module is not easily accessible: Enter the module ID into the Module ID text field**

Enter the module ID found on the label inside the cover of the module into the field and TAB to the **Save** button and press **ENTER**, then skip to **Step 8**.

### **Step 6 If the module is easily accessible: TAB over to the Learn Button on the Command Terminal**

After creating the module and assigning the number, TAB over to the Learn button and press ENTER. A dialog box displays requesting the operator to press the Commission button on the physical module.

### **Step 7 On local Modules: Press the Commission button on the Module**

Press the Commission button found on the front panel of the module. Clicking this button sends information from the module to the Command Terminal. When you push the Commission button, the dialog box should disappear indicating that it received the information from the module.

### **Step 8 On the Command Terminal: Save the Form**

When you save the form you should notice that the ModuleID for commissioned modules, the ProgramID field and the IO model type (i.e. AO-4-8) are automatically entered. This information was received from the module. Also, the CommStatus should indicate an OnLine status.



## Commissioning a Replacement I/O Module - CyberStation

When you replace an I/O module\*\*, proceed as follows:

***Remove power from the I/O Bus where the module is to be installed***

**Note:** This procedure is for all modules except when replacing an AC-1 with an AC-1. For that procedure, follow the instructions in the next section.

- Step 1     Replace the module, re-apply power**  
Remove the old module, connect the new module in its place & re-apply power.
- Step 2     From CyberStation: Open the IOU Module Editor**  
Log onto a CyberStation and open the IOU Module editor of the IOU that is being replaced.
- Step 3     From CyberStation: Type in the new Module ID text field**  
Enter the module ID found on the label inside the cover of the new IOU module into the field and click the **Apply** button.
- Step 4     From CyberStation: Verify the new IOU Module is online**  
Click **Refresh**. You should notice that in the **ModuleID** field for the commissioned module, the ProgramID field and the IO model type (i.e. AO-4-8) are automatically entered. This information was received from the module. Also, the Comm Status should indicate an on-line status.

## Commissioning a Replacement I/O Module – Command Terminal

When you replace an I/O module\*\*, proceed as follows:

***Remove power from the I/O Bus where the module is to be installed***

**Note:** This procedure is for all modules except when replacing an AC-1 with an AC-1 Plus. For that procedure, follow the instructions in the next section.

- Step 1     Replace the module, re-apply power**  
Remove the old module, connect the new module in its place & re-apply power.
- Step 2     From the Command Terminal: Edit the IOU Module**  
Log onto a Command Terminal and edit the IOU Module (select Edit, then IOU Modules, then press F2 to bring up the list of IOU Modules).
- Step 3     From the Command Terminal: Enter the new module ID into the Module ID text field**  
Enter the module ID found on the label inside the cover of the module into the **Module ID** field and TAB over to the **Save** button then press ENTER.

#### **Step 4 From the Command Terminal: Verify the new IOU Module is online**

Edit the IOU Module that was replaced (select Edit, then IOU Modules, then press F2 to bring up a list of the IOU Modules, select from the list and press ENTER). You should notice that the **ModuleID** field for the commissioned module, the ProgramID field and the IO model type (i.e. AO-4-8) are automatically entered. This information was received from the module. Also, the Comm Status should indicate an Online status.

### **Replacing an AC-1 with an AC-1 Plus Module - CyberStation**

When you substitute an AC-1 Plus for an AC-1 module, proceed as follows:

#### **Step 1 Place Cyberstation in OffLine Edit Mode**

#### **Step 2 Record the AC-1 IOU Number**

Open the AC-1 module editor and note the module's ID (IOU field in the editor)

#### **Step 3 Close the AC-1 editor**

#### **Step 4 Delete the AC-1 module (still offline)**

*Remove power from the I/O Bus where the module is to be installed*

#### **Step 5 Replace the AC-1 with an AC-1 Plus**

Physically remove the AC-1 and Replace with an AC-1 Plus and re-apply power to the I/O Bus.

#### **Step 6 Create a new IOU Module**

Create a new IOU module through CyberStation Explorer (still offline) using the same IOU Number as the AC-1 (NOTE: **New IOU name DOES NOT** have to match old AC-1 name)

#### **Step 7 Enter the new ModuleID**

Enter the ModuleID of the new AC-1 Plus (ex: 00-03-63-27-61-00) into the module ID field.

#### **Step 8 Save the new AC-1 Plus module (click OK) and close the editor**

*Repeat steps 2 through 8 for all AC-1 to AC-1Plus replacements*

#### **Step 9 Place CyberStation back online**

#### **Step 10 Reload the controller**

#### **Step 11 Open, then close each AC-1 Plus Module editor**

After reload is complete, open and close each AC-1 Plus module editor (this step is necessary to relay some information from the controller to the database)

**Note:** The AC-1 Plus has operational differences from AC-1 and AC-1A modules (i.e. Degrade mode). Please refer to the AC-1, AC-1A and AC-1 Plus sections of this manual for further information.

## Replacing an AC-1 with an AC-1 Plus Module – Command Terminal

When you substitute an AC-1 Plus for an AC-1 module, proceed as follows:

- Step 1 Record the AC-1 IOU Number**  
Open the AC-1 module editor and note the module's ID (IOU field in the editor)
- Step 2 Close the AC-1 module editor**
- Step 3 Open the door editor**  
Open the door editor for the door that is associated with the AC-1 to be replaced and set the entry IOU (or exit IOU if appropriate) to 0 (zero).
- Step 4 Save and close the door editor**
- Step 5 Delete the AC-1 module**

*Remove power from the I/O Bus where the module is to be installed*

- Step 6 Replace the AC-1 with an AC-1 Plus**  
Physically remove the AC-1 and Replace with an AC-1 Plus and re-apply power to the I/O Bus.
- Step 7 Create a new IOU Module**  
Create a new IOU module using the same IOU Number as the AC-1 (NOTE: **New IOU name DOES NOT** have to match old AC-1 name)
- Step 8 Learn the AC-1 Plus Module**  
Perform a Learn operation, or populate the Module ID field with the Module ID of the new AC-1 Plus Module.
- Step 9 Save the new AC-1 Plus module and close the editor**
- Step 10 Re-open the door object**  
Re-open the door object changed in Step 3 and restore the entry IOU (or exit IOU if applicable) number, then save and close the door editor.

# Individual Module Wiring

This section of the document describes the various I/O modules and presents interfacing information. Each module is presented in its own mini-section. The part number designator for the module being described is printed on the outer edge of each page.

## General Wiring Concerns for All Modules

Do not remotely ground any part of the input sensor wiring. Remote grounds connected to the return terminal could make the system operate incorrectly or damage the equipment. The signal return is not true earth ground. It is an electronic reference point necessary to interpret the sensor properly.

It is recommended that you run input wiring in a conduit separate from AC power or output wiring and avoid long wiring runs.

For reliable input operation, follow these input wiring guidelines:

- Never lay wires across the surface of a printed circuit board.
- Wires should never be within 1 in. or 25 mm of any component on a printed circuit board.
- Use shielded input wire.
- Terminate the shield of the input wires at one end of the run only—preferably at the end where your I/O module is located.
- Be careful when stripping wire not to drop small pieces of wire inside the cabinet.
- Don't run your input wiring in the same conduit with AC power.
- Don't run your input wiring in the same conduit with your output wiring.
- Don't run high and low voltage wiring in the same conduit.

### ----- IMPORTANT -----

## Grounding the Modules

All I/O modules except the VS-8 include a metal clip that is built into the locking mechanism on the back of the case. Mounting the module on a metal surface or DIN rail automatically provides an Earth ground. The VS-8 includes a ground stud that must be connected to Earth ground. It is important that this connection be made as close to the module as possible.

### **Caution**

***Do not externally ground any input signal connected to the module. This may damage the unit. Signal return terminals are not connected to Earth Ground.***

When installing Andover Continuum I/O modules it is **imperative** that the installer su a solid Earth ground connection to the pins provided.

## ***Electro Static Discharge (ESD) Warning***

To avoid damaging electronic components due to the discharge of static electricity, always ground yourself before touching any boards or other internal components of Schneider Electric devices.

- At the *very least*, touch metal first.
- If possible, use a grounding strap or heel plate.

On each I/O module, the left-most pin is labeled with a ground symbol and should have a short earth ground connection made to it. The wire should be as short as possible, ideally 6 inches or less, and the wire gauge should be a minimum of 18 AWG.

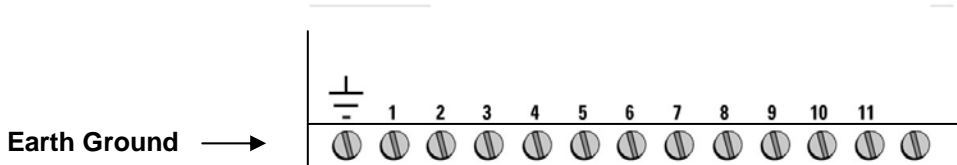

**Failure to install these grounds can result in controller resets or physical damage to the CPU or I/O modules.**

Later shipments of I/O Modules include a grounding clip built into the DIN Rail clamp of the module. If the Din Rail itself is grounded you will no longer need to ground the I/O modules. You will still need to ground the CPU Modules.

**Limitations of Non-Volatile Memory**

Flash memory devices used in our products are guaranteed for a minimum of 10,000 write operations. Flash memory is for storing completed configurations and a snapshot of data at a particular time. When used in this manner, the memory should last the lifetime of the product.

## UI-8-10, UI-8-10-10V Universal Input Modules

The UI-8-10, *Andover Continuum's* universal input module, provides 8 universal inputs, software configurable as voltage, thermistor, digital, or counter point types. Each point can also be configured as a supervised input for security monitoring, providing indication of on/off and trouble conditions. This module is a perfect choice for any mix of temperature, pressure, flow, status points, and similar inputs in a control system, with a 0-5 volt input range and 10 bit A/D conversion.

The UI-8-10-10V model is available for 0–10V applications. It provides the identical point type selection; but is equipped with individual voltage divider DIP switches on each input, allowing each to be configured for a 0–10 volt range.

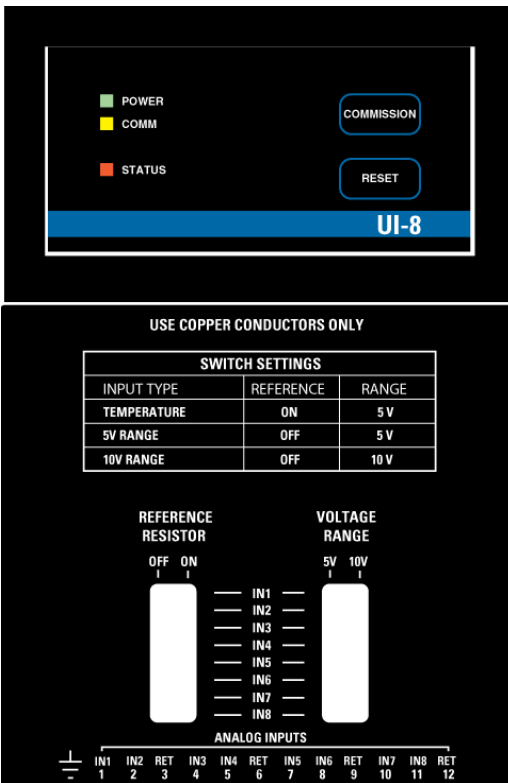

### FEATURES

- 8 Universal Inputs
- 10 bit Resolution
- 0–5V or 0–10V Input Range
- Supports Voltage, Thermistor, Digital, Counter and Supervised Electrical Types
- Pull-up Resistor Disable Switches
- 10–28 V Power Supply Range

## SPECIFICATIONS

### ELECTRICAL

**Power Supply Range:** *Input Voltage Range: 10-28V. 24V for UL864 and UL294 installations.*

**Power Consumption:** 0.7 Watt (29 mA) @ 24VDC (max.); normally provided by *Andover Continuum* power supply module.

**Overload Protection:** 0.5 A resettable fuse with transient voltage suppressor (TVS) and reverse polarity protection.

### INPUTS

**Number of Inputs:** 8 Universal inputs; 10 bit resolution

**Input Types:** Voltage, Thermistor, Digital, Counter, and Supervised

**Input Protection:** 24V AC/DC allowed to any single input (40V transient voltage suppressor on each input – UI-8-10-10V)

**Input Impedance:** 5 M $\Omega$  w/pull-up disabled; 10 K $\Omega$  w/pull-up enabled – UI-8-10 (4.4 K $\Omega$  in 0-10V mode UI-8-10-10V)

**Input Connections:** Two-piece, 13-position removable terminal block

<b>Voltage:</b>	<b>UI-8-10 (0-5V)</b>	<b>UI-8-10-10V (0-10V mode)</b>
Range:	0-5 volts	0-10 volts
Resolution:	5 mV	10 mV
Accuracy:	$\pm 15$ mV ( $\pm 0.3\%$ FSR)	$\pm 40$ mV ( $\pm 0.4\%$ FSR)
Filtering:	Corner Frequency at 15 Hz, -20 db/decade	
Calibration:	Permanent (factory)	

### **Thermistor:**

Type: 10 K $\Omega$ , Type III Thermistor

Range: -30 to 230°F (-34 to 110°C)

Resolution: 40 to 100°F range 0.20°F typical  
(4 to 38°C) (0.11°C typical)

Accuracy: 40 to 100°F range  $\pm 1.0^\circ\text{F}$  (includes 0.36° error for thermistor)  
(4 to 38°C) ( $\pm 0.55^\circ\text{C}$ )

### **Digital & Counter:**

Input Type: Contact Closure

Frequency: 4 Hz max.

Pulse Width: 125 ms min. (depends on scan time)

### **Supervised:**

Input Type: Single or Double Resistor Supervision, Parallel or Series Circuit



## I/O Connections

The actual input connections are located on a thirteen-position removable screw terminal connector located at the bottom of the module.

The inputs are labeled IN1, IN2, IN3, and so forth. Each pair of inputs is followed by its return connection labeled RET, resulting in a sequence of IN1, IN2, RET, IN3, IN4, RET, and so on.

The connector allows for an Earth ground connection, eight inputs and four signal returns.

The diagram screen printed on the module indicates where each input number is located on the terminal block. These connections are also listed below.

Connection	Description
	Earth Ground
1.	IN 1
2.	IN 2
3.	RETURN
4.	IN 3
5.	IN 4
6.	RETURN
7.	IN 5
8.	IN 6
9.	RETURN
10.	IN 7
11.	IN 8
12.	RETURN

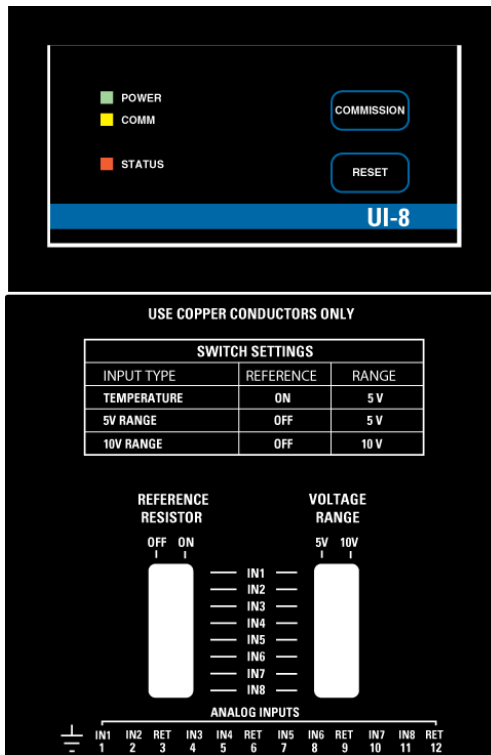

## Input Circuitry

UI-8-10 Inputs are essentially voltmeters. Universal inputs can be configured through software to become one of five different input circuits:

- Temperature
- Voltage
- Digital
- Counter
- Supervised

During configuration, the value of the Electrical Type attribute you select tells the controller how to interpret the reading from each input.

The following is a simplified schematic of both the UI-8-10 and the UI-8-10-10V Universal inputs:

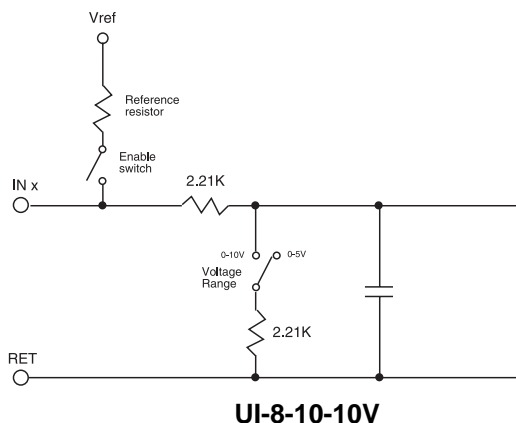
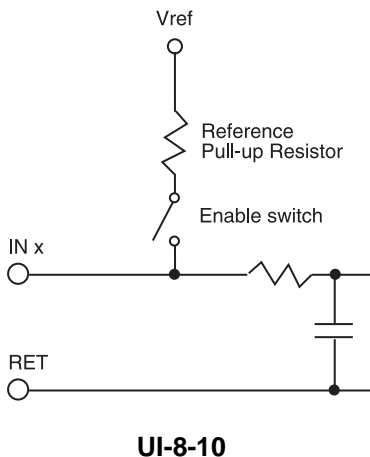

The main difference between the two is the UI-8-10-10V circuit includes a switch selectable front-end voltage divider that effectively divides the 10V input signal by two. The proper switch settings for various modes of operation are listed on the front for the module.

**Note:** Setting the reference resistor enable switch to 'ON' and setting the range to '10V' is invalid.

Each input includes a low-pass filter after the pull-up formed by a series resistor and a parallel capacitor. The resistor is utilized for over-voltage protection in limiting current to two protection diodes (not shown). It is possible to have more than one input share a single return wire. Keep in mind that the current through each input is approximately 0.3mA, so voltage drops occur with long runs of small gauge wire.

**Pull-up Reference Resistor Selection Switches**

In some measuring instances it is desirable that there be no pull-up resistor. Instead of physically removing or cutting the resistor off the printed circuit board, the input module includes a pull-up resistor selection switch for each input position. This switch allows you to select whether or not you want a pull-up resistor in the circuit. A small 8-position switch module is accessible from the front of the module when the door is opened.

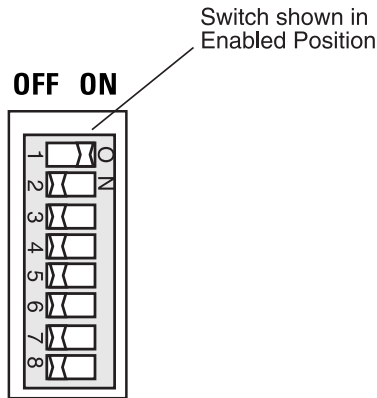

These switch modules are commonly called “DIP Switches” and require a small object such as the tip of a pen or a small screwdriver to operate them. Each switch position acts as a “slide switch”. Pressing the raised slide marker to the side marked “on” closes or enables the switch. To open or disable the switch position, press the slide marker over to the “off” side.

**Input Voltage Range Selection Switches (UI-8-10-10V Only)**

The UI-8-10-10V module allows you to choose from two input voltage ranges. Selection is accomplished by using a switch arrangement that is similar to the operation of the pull-up resistor switches. This small 8-position switch module is located to the right of the pull-up selector switch and is accessible from the front of the module when the door is opened.

The Voltage Range switches allow you to select a range (0-5 V) or (0-10 V) for each input.

The 0-5V range allows connections to signals that do not exceed 5.00V.

The 0-10V range allows connection to signals up to 10.00V. In this mode the circuit actually uses the same input measuring circuit as the 0-5V range, however, it divides the voltage present by two thereby limiting the internal circuitry to 0-5V. When you read a 0-10V input the actual reading will be 0-5V. You must adjust your readings for the higher range via formula. This is accomplished by applying a conversion factor to the reading. When creating a 10V InfinityInput, set the Conversion to  $\text{ElecValue} * 2$ .

When using the 10V mode be sure to set the Reference resistor switch to Off.

**Note: Setting the Reference Resistor enable switch to 'ON' and setting the Range to '10V' is invalid. Switching to 10V inputs dramatically lowers the impedance of the input to 4.4 K $\Omega$ .**

## Supervisory Inputs

UI-8 inputs may be connected as supervisory inputs. The following drawings depict the three types of supervisory inputs that exist—three normally closed and three normally open types.

### Normally Closed Supervised Inputs

#### NC Series

With this type of input wiring, a resistor is placed in series with the input being monitored. When the input contact presents a short circuit (normal closed position) the input is assumed in a normal closed state, the circuit presents a reading of 10 K  $\Omega$ s at the input.

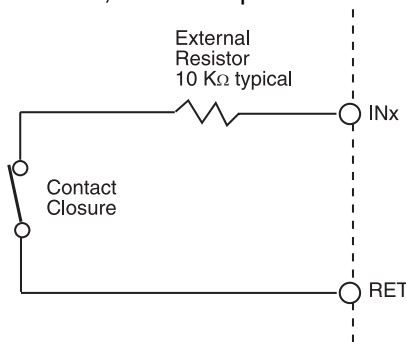

#### Circuit Action

Switch Closed  
 Switch Opened  
 Wire Cut  
 Input Shorted

#### Input Senses

External Resistance  
 Infinite Resistance  
 Infinite Resistance  
 Zero  $\Omega$ s

#### Condition

Input contact Closed  
 Input contact Open  
 Input contact Open 'Violation'  
 Violation or error

When the input contact is opened, the circuit opens and an infinite resistance is measured. If the wires to the input contact are cut it also appears as an “input contact open” condition. In this case there would be an input contact open without a valid card swipe or valid keypad entry resulting in an “input contact violation”. Shorting the input causes a zero  $\Omega$  resistance, which also results in an input contact violation.

When configuring for this type of contact select:

**ElecType:**       **Supervised**  
**Resistor Type:** **NCSeries**

## Normally Closed Supervised Inputs

### NC Series Parallel

With this type of input wiring, two external resistors are added to the input, one in series and the other in parallel. When the input contact switch is closed (normal position) the input contact is assumed to be closed. The circuit presents a reading composed of both resistances in parallel that works out to be half the value of one of them (5 K $\Omega$ ).

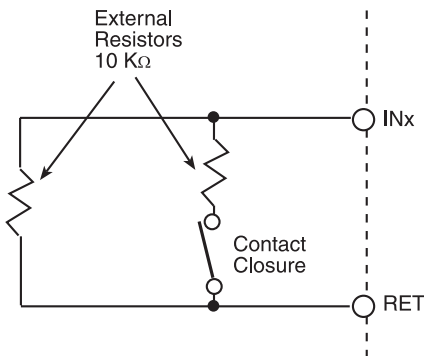

Circuit Action	Input Senses	Condition
Switch Closed	External Resistance $\div 2$	Input contact Closed
Switch Opened	External Resistance	Input contact Open
Wire Cut	Infinite Resistance	Violation or error
Input Shorted	Zero $\Omega$ s	Violation or error

When the input contact is opened the switch opens and the value of the parallel resistor is measured. If the wires to the input contact are cut it appears as an infinite resistance. Shorting the input causes a zero  $\Omega$  resistance. Both a short and an infinite resistance (open) should result in an error condition.

When configuring for this type of contact select:

**ElecType:**        **Supervised**  
**Resistor Type:** **NC SerPar**



## Wiring Door Switches

There are three supervisory inputs for door switches. The maximum length wire you may use is 500 ft of #18 gauge wire (152 m of 1.0 mm<sup>2</sup> wire) or 200 ft of #22 gauge wire (60 m of 0.35 mm<sup>2</sup> wire).

Some switches have built-in resistors that facilitate Series Parallel connections as shown below:

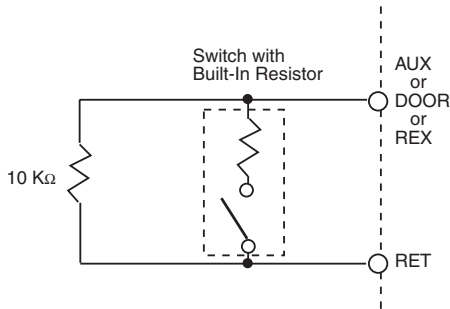

## Wiring Motion Detectors

Motion detectors are devices that close a switch contact when motion is detected.

Wiring is similar to a normal input contact switch input, however, the motion sensor requires an external power supply of 12 VDC or 24 VDC (UL listed under APHV). The maximum length wire you should use is 500 ft of #18 gauge wire (152 m of 1.0 mm<sup>2</sup> wire) or 200 ft of #22 gauge wire (60 m of 0.35 mm<sup>2</sup> wire).

The following shows a typical motion detector circuit:

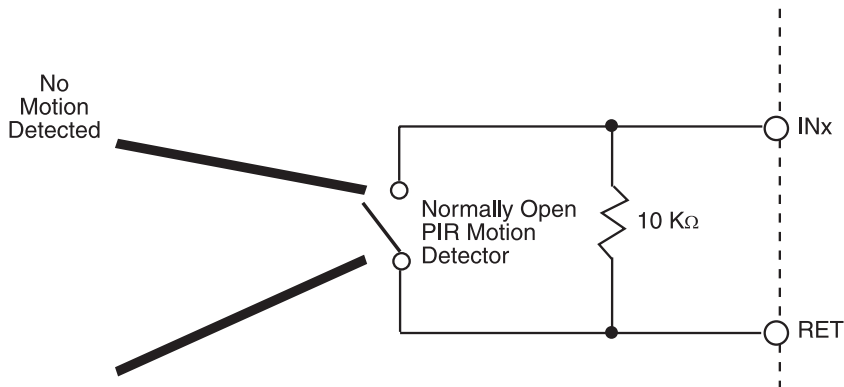



## Measuring Temperature

UI-8-10 inputs can be configured to sense temperature by configuring one of the module's inputs appropriately. This is done by setting the Electrical Type to either **ACC Temp (DEG F)** or **ACC Temp (DEG C)**. Connect a resistive thermistor sensor to that input terminal. The following is a schematic representation of the connection:

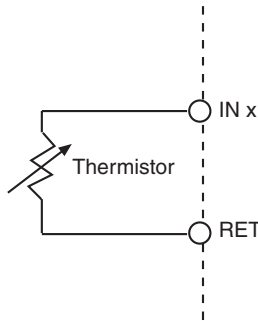

One lead connects to a numbered input terminal, the other to a return terminal.

To use the input for temperature sensing, the pull-up reference resistor must be connected into the circuit, therefore, **the reference resistor switch for this input must be placed in the “on” position and the Range switch must be in the 5V position.** When the input point is configured as a temperature input, the controller utilizes a look-up table to convert from a voltage reading to a temperature reading in degrees Fahrenheit or Celsius.

### **Caution**

Never apply voltage to a thermistor—doing so alters the thermistor's accuracy and reliability. In fact, it's a good idea to replace any thermistor that has had any sort of voltage applied to it.

### **Maximum Wire Runs for Thermistors**

To keep thermistor errors to a minimum, limit the length of wire runs to the maximum for the gauge wire you select.

The following two pages include three tables that indicate the maximum length runs for wires of various gauges to keep errors within certain temperature limits when using thermistor elements.

**Wire Gauges and Corresponding Maximum Runs for  
Sensing Temperatures Up to 70 °F (21 °C)**

<b>Gauge</b>	<b>1/2 °F (.28 °C) Error</b>	<b>1/4 °F (.14 °C) Error</b>	<b>1/10 °F (.06 °C) Error</b>
#14 2.5 mm <sup>2</sup>	26,700 ft. 8150 m	13,300 ft. 4000 m	5,300 ft. 1600 m
#16 1.5 mm <sup>2</sup>	16,700 ft. 5120 m	8,300 ft. 2500 m	3,300 ft. 1000 m
#18 1.0 mm <sup>2</sup>	10,500 ft. 3200 m	5,200 ft. 1600 m	2,100 ft. 640 m
#20 0.5 mm <sup>2</sup>	6600 ft. 2000 m	3,300 ft. 1000 m	1,300 ft. 400 m
#22 0.35 mm <sup>2</sup>	4,100 ft. 1250 m	2,000 ft. 600 m	800 ft. 250 m

**Wire Gauges and Corresponding Maximum Runs for  
Sensing Temperatures Up to 100 °F (38 °C)**

<b>Gauge</b>	<b>1/2 °F (.28 °C) Error</b>	<b>1/4 °F (.14 °C) Error</b>	<b>1/10 °F (.06 °C) Error</b>
#14 2.5 mm <sup>2</sup>	12,600 ft. 3800 m	6,300 ft. 1900 m	2,500 ft. 760 m
#16 1.5 mm <sup>2</sup>	7,900 ft. 2400 m	3,900 ft. 1200 m	1,500 ft. 450 m
#18 1.0 mm <sup>2</sup>	5,000 ft. 1500 m	2,500 ft. 760 m	1,000 ft. 300 m
#20 0.5 mm <sup>2</sup>	3,100 ft. 950 m	1,500 ft. 450 m	600 ft. 180 m
#22 0.35 mm <sup>2</sup>	1,900 ft. 580 m	900 ft. 275 m	300 ft. 90 m

**Wire Gauges and Corresponding Maximum Runs for  
Sensing Temperatures Up to 150 °F (65 °C)**

<b>Gauge</b>	<b>1/2 °F (.28 °C) Error</b>	<b>1/4 °F (.14 °C) Error</b>	<b>1/10 °F (.06 °C) Error</b>
#14 2.5 mm <sup>2</sup>	4,100 ft. 1250 m	2,000 ft. 600 m	800 ft. 240 m
#16 1.5 mm <sup>2</sup>	2,600 ft. 800 m	1,300 ft. 400 m	500 ft. 150 m
#18 1.0 mm <sup>2</sup>	1,600 ft. 500 m	800 ft. 240 m	300 ft. 90 m
#20 0.5 mm <sup>2</sup>	1,000 ft. 300 m	500 ft. 150 m	200 ft. 60 m
#22 0.35 mm <sup>2</sup>	600 ft. 180 m	300 ft. 90 m	100 ft. 30 m

## Measuring DC Voltages

The UI-8-10 inputs may be configured to sense DC voltage by connecting the input terminals to a DC voltage source within the range of the module's input specifications. The following is a schematic representation of the connection:

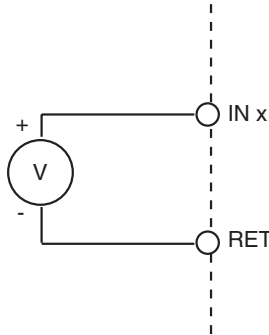

The plus lead connects to the numbered input terminal, the other to a return terminal.

When interfacing to a voltage output sensor, specific information on the transducer may be required. The pull-up resistor of the input circuit will affect the output of the transducer.

### 10V Input Notes

Although the 10V input configuration allows you to measure a higher voltage, it is scaled so that you still measure a value of 0-5V. You have to convert the reading in your conversion equation. When the input is configured for 10V operation, the input resistance is 4.4kΩ. Therefore, the sensor would have to be able to source as much as 2.3mA.

When configuring either type of voltage input, select:

**ElecType:**                      **Voltage**  
**Reference Resistor**          **OFF**

## Voltage Dividers

There are instances when it is necessary to interface to a voltage source that is higher than the input range of the module. In these cases a voltage divider is necessary.

### External DC input Voltage Divider

Two resistor values set up a ratio of voltage drop. These resistors must be sized appropriately (value and wattage) for the source being monitored. The higher the resistance values, the less loading effect there will be on the source.

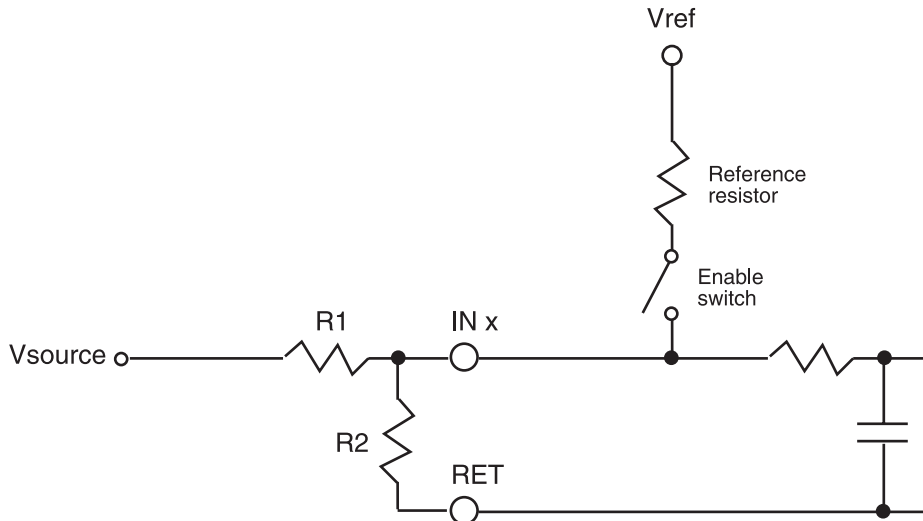

The circuit shown above is a simple two-resistor voltage divider connected to one of the UI-8-10 module's inputs. The input circuitry of the module can measure a maximum of either 5 Volts or 10 Volts (UI-8-10-10V only). Therefore, the voltage measured across the reference resistor must not exceed this maximum.

In this case, be sure to switch the pull-up resistor out of the circuit.

Assuming you know the maximum voltage reading you are trying to measure (**V<sub>source</sub>**), perform the following steps to determine the resistance values necessary to condition the input for the module. **If you have the UI-8-10-10V model, set the Range switch to 5V.**

1. First, determine the current that will flow through the divider. Pick a value that your source can supply. Let's say 20 mA. This value will be represented by the variable **I<sub>total</sub>** in the following equations.
2. Determine the total resistance value required of the entire divider (R1 + R2) to create 20mA given the source voltage by solving the following:

$$R_{total} = \frac{V_{source}}{I_{total}}$$

Example: if you are measuring a source that can supply 0- 30 V:

$$R_{total} = \frac{30 \text{ V}}{20 \text{ mA}}$$

$$R_{total} = \frac{30 \text{ V}}{.02 \text{ A}}$$

$$R_{total} = 1500 \Omega$$

The current is constant through the two resistors. Knowing this and the fact that our input can't exceed 5V can determine the value of the resistor labeled **R2**.

3. Determine the value of **R2** by solving the following:

$$R_2 = \frac{V_{input}}{I_{total}}$$

$$R_2 = \frac{5 \text{ V}}{.02 \text{ A}}$$

$$R_2 = 250 \Omega$$

Through subtraction, you can determine the remaining resistor value:

$$R_{total} = R_1 + R_2$$

$$R_1 = 1500 \Omega - 250 \Omega$$

$$R_1 = 1250 \Omega$$

## Sensing Contact Closures (Digital)

Digital input points are designed to allow the monitoring of contact closures across an input (contact wired between the input and return).

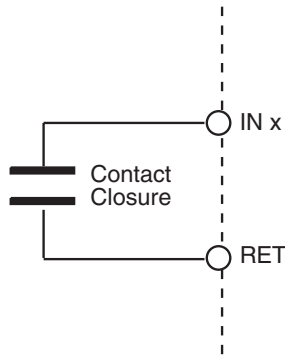

**Note:** When configuring a Digital point, there is a “Polarity” attribute. If this attribute is enabled, readings are reversed: “On” will occur when the contact is open, and “Off” occurs when the contact is closed.

When configuring this type of input, select:

**ElecType:**                      **Digital**  
**Reference Resistor**        **ON**

## Counting Pulsing Signals or Contact Closures

Counter inputs are designed to allow the monitoring of digital pulse trains or contact closures across an input just like digital inputs, but they accumulate a total of those closures and act like a counter.

When using an input as a counter, you must take into account the frequency of the input signal being counted. Universal inputs do not allow for very high speed contact counting. This module allows counting up to a maximum of 4 Hz or 4 contact closures per second.

### *Minimum Pulse Width*

The high period of the signal must be at least 125 milliseconds.

The low period of the signal must be at least 125 milliseconds.

When configuring this type of input, select:

<b>ElecType:</b>	<b>Counter</b>
<b>Reference Resistor</b>	<b>ON</b>

## Status/Control Panel

### Status Indicators

The UI-8-10 module includes a complete indicator status panel on the front of the module.

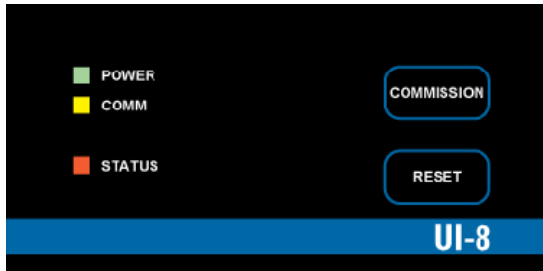

This panel includes indicators reporting on the status of the following:

- POWER** This green indicator illuminates when DC power is applied through the I/O Bus.
- COMM** This yellow indicator illuminates when data is transmitted from the module to the NetController. In normal operation, data is only transmitted when an input value changes.
- This indicator will also flash periodically as the NetController checks the I/O bus.
- STATUS** This red indicator is normally off. If it is always on or flashing at a fast rate there is a problem with the module.
- This indicator can be manually illuminated from the CyberStation workstation or Command Terminal Interface and used as a troubleshooting aid when locating a particular module.

This panel also includes two operator switches that perform the following:

- COMMISSION** After physical installation and during configuration through the CyberStation workstation or Command Terminal Interface, pressing this button registers the module's address with the system. For more information, refer to the section on *Module Configuration* found earlier in this manual.
- RESET** If the module becomes inoperable, pressing this button resets the module. It does not erase its memory.



## DI-6-AC, DI-6-AC-HV Digital AC Input Modules

The DI-6-AC, Andover Continuum’s digital AC input module, has six digital (“wet”) AC inputs for cost-effective ON-OFF status indication of fan motor starters, solenoid valves, control relays, or external power supplies, and similar applications that require a quick and easy way to detect voltage. The DI-6-AC monitors the absence or presence of AC voltage levels directly, with no interposing relays needed.

The DI-6-AC can monitor voltages from 20–132V. A DI-6-AC-HV model is also available for sensing higher voltages (90–250V). Both models can also accept DC voltages. All inputs are optically coupled with 2500V isolation on each input for noise-free operation.

The image shows the front panel of the DI-6-AC module. At the top, there are six status LEDs: POWER (green), COMM (yellow), STATUS (red), and three unlabeled red LEDs. Below these are six input indicators labeled INPUT 1 through INPUT 6. To the right are two buttons: COMMISSION and RESET. The module is labeled 'DI-6' at the bottom. Below the panel, there are safety warnings in English and French, a comparison table for DI-6-AC and DI-6-AC-HV models, and a terminal block diagram for digital inputs.

**USE COPPER CONDUCTORS ONLY**

**WARNING:** HIGH VOLTAGE INSIDE-DANGEROUS TO UNQUALIFIED PERSONS.

**AVERTISSEMENT:** HAUTE TENSION A L'INTERIEUR-DANGER POUR LES PERSONNES NON-QUALIFIER.

**CAUTION:** MORE THAN ONE DISCONNECT MAY BE REQUIRED TO DE-ENERGIZE THIS EQUIPMENT.

	DI-6-AC	DI-6-AC-HV
VOLTAGE RANGE(VAC) 50/60 HZ	20 - 132	90 - 280
INPUT CURRENT(mA)	0.4 - 9.0	0.4 - 3.0

**DIGITAL INPUTS**

Terminal block diagram showing connections for IN1 through IN6. Each input is connected to a pair of terminals (1-2, 3-4, 5-6, 7-8, 9-10, 11-12). A ground symbol is shown on the left.

### FEATURES

- 6 optically-coupled, digital AC input channels
- Independently Mounted
- Will accept AC or DC inputs
- 20–132V AC Input Range (DI-6-AC)
- 90–250V AC Input Range (DI-6-AC-HV)

## SPECIFICATIONS

### ELECTRICAL

**Power Supply Range:** Input Voltage Range: 20-26V.

**Power Consumption:** 0.7 Watt (29 mA) @ 24VDC (max.); normally provided by *Andover Continuum* power supply module.

**Overload Protection:** 0.5 A resettable fuse with transient voltage suppressor (TVS) and reverse polarity protection.

### INPUTS

**Number of Inputs:** 6 digital AC voltage inputs

**Input Protection:** 2500V isolation on each input.  
Each input has a 270V MOV.

**Input Connections:** Two-piece, 13-position removable terminal block

	<b>DI-6-AC</b>	<b>DI-6-AC-HV</b>
<b>Input Range:</b>	20–132 Vrms	90–250 Vrms
<b>Input Current:</b>	5 mA max.	2 mA max.

	<b>DI-6-AC</b>	<b>DI-6-AC-HV</b>
<b>AC Voltage “ON” Threshold:</b> (Above this voltage is considered “ON”)	16 Vrms	75 Vrms
<b>AC Voltage “OFF” Threshold:</b> (Below this voltage is considered “OFF”)	8 Vrms	30 Vrms
<b>Input Resistance (<math>\pm 5\%</math>):</b>	30 K $\Omega$	200 K $\Omega$
<b>Maximum Turn ON Time:</b>	20 mS	20 mS
<b>Maximum Turn OFF Time:</b>	60 mS	60 mS
<b>DC Input Voltage Range:</b>	20–132V	90–250V
<b>Pulse Width:</b>	125mS min. (depends on scan time)	
<b>DC Input Current:</b>	5mA (max.)	2mA (max.)
<b>DC Voltage “ON” Threshold:</b>	20V	90V
	(Above this voltage is considered “ON”)	
<b>DC Voltage “OFF” Threshold:</b>	12V	45V
	(Below this voltage is considered “OFF”)	

### EUROPEAN STANDARDS

European Multi-Purpose Control–Electronic

Type 1B–Micro Disconnect

## I/O Connections

The actual input connections are located on a thirteen-position removable screw terminal connector located at the bottom of the module.

The inputs are labeled IN1, IN2, IN3, and so forth. Each pair of terminals corresponds to one input. With both AC and DC signals there is no polarity to observe during connection.

The connector allows for an Earth ground connection, eight inputs and four signal returns.

The diagram screen printed on the module indicates where each input number is located on the terminal block. These connections are also listed below.

### Connection Description

	Earth Ground
1.	IN 1
2.	IN 1
3.	IN 2
4.	IN 2
5.	IN 3
6.	IN 3
7.	IN 4
8.	IN 4
9.	IN 5
10.	IN 5
11.	IN 6
12.	IN 6

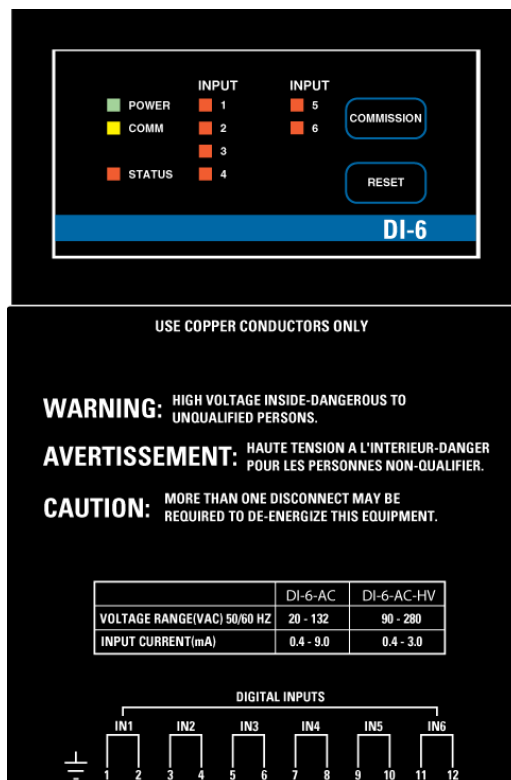

The image shows the front panel of the DI-6 module and a terminal block diagram. The front panel includes a legend for POWER (green), COMM (yellow), STATUS (orange), and INPUT (red) terminals. It also features COMMISSION and RESET buttons. The terminal block diagram shows 12 terminals, with pairs 1-2 through 11-12 labeled IN1 through IN6, and a ground symbol at terminal 12.

**USE COPPER CONDUCTORS ONLY**

**WARNING:** HIGH VOLTAGE INSIDE-DANGEROUS TO UNQUALIFIED PERSONS.

**AVERTISSEMENT:** HAUTE TENSION A L'INTERIEUR-DANGER POUR LES PERSONNES NON-QUALIFIER.

**CAUTION:** MORE THAN ONE DISCONNECT MAY BE REQUIRED TO DE-ENERGIZE THIS EQUIPMENT.

	DI-6-AC	DI-6-AC-HV
VOLTAGE RANGE(VAC) 50/60 HZ	20 - 132	90 - 280
INPUT CURRENT(mA)	0.4 - 9.0	0.4 - 3.0

DIGITAL INPUTS

IN1 IN2 IN3 IN4 IN5 IN6

1 2 3 4 5 6 7 8 9 10 11 12

## Input Circuitry

The following is a simplified schematic of both the DI-6-AC and the DI-6-AC-HV Digital Input module:

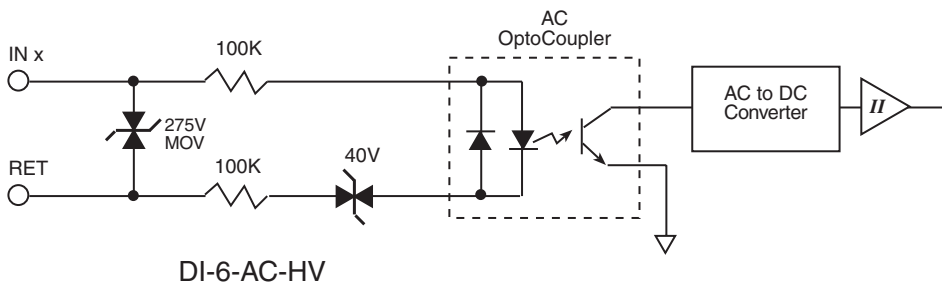
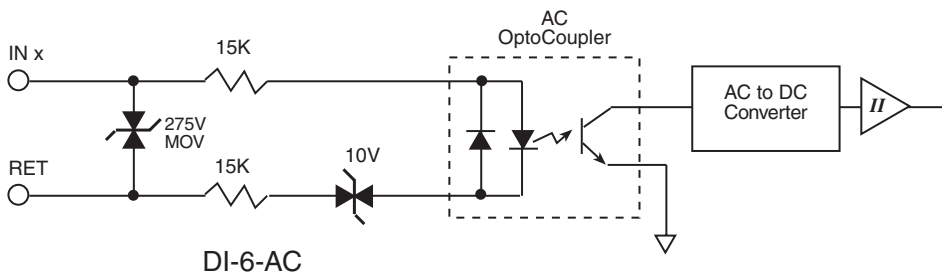

The main difference between the two is the DI-6-AC-HV circuit includes a front end that supports the higher voltages.

## Sensing AC or DC Digital Inputs

Digital input points are designed to provide an ON or OFF reading of a signal. Normally you would associate an AC or DC voltage input with a value measurement, however, the DI-6 modules include a voltage level trigger that senses the presence of a range of voltages and converts those readings to ON and OFF indications.

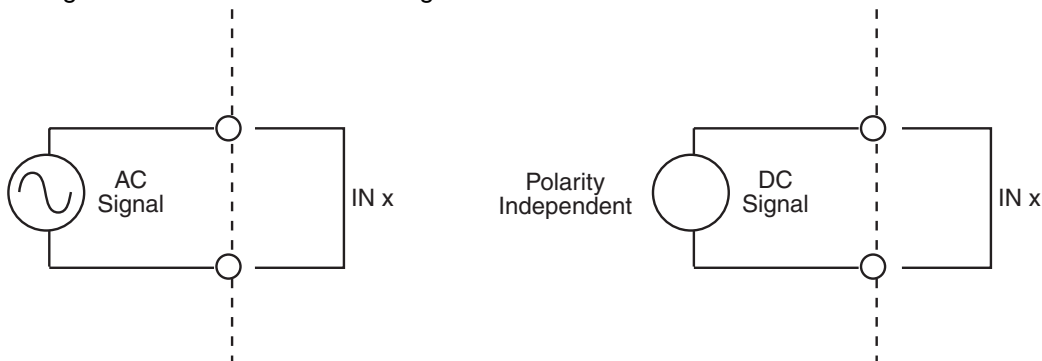

The determination of ON or OFF is based upon the following measurement thresholds:

	<b>DI-6-AC</b>	<b>DI-6-AC-HV</b>
<b>AC Voltage "ON" Threshold:</b> (Above this voltage is considered "ON")	16 Vrms	75 Vrms
<b>AC Voltage "OFF" Threshold:</b> (Below this voltage is considered "OFF")	8 Vrms	30 Vrms
<b>DC Voltage "ON" Threshold:</b> (Above this voltage is considered "ON")	20V	90V
<b>DC Voltage "OFF" Threshold:</b> (Below this voltage is considered "OFF")	12V	45V

**Note:** When configuring a Digital point, there is a 'Polarity' attribute. If this attribute is enabled, readings are reversed: 'ON' will occur when the input is at the normal OFF threshold. OFF occurs at the normal ON threshold.

When configuring either type of input, select:

**ElecType:**                      **Digital**

## Status/Control Panel

### Status Indicators

The DI-6-AC module includes a complete indicator status panel on the front of the module.

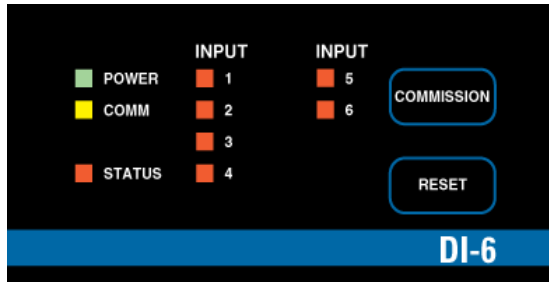

This panel includes indicators reporting on the status of the following:

- POWER** This green indicator illuminates when DC power is applied through the I/O Bus.
- COMM** This yellow indicator illuminates when data is transmitted from the module to the NetController. In normal operation, data is only transmitted when an input value changes.
- This indicator will also flash periodically as the NetController checks the I/O bus.
- STATUS** This red indicator is normally off. If it is always on or flashing at a fast rate there is a problem with the module.
- This indicator can be manually illuminated from the CyberStation workstation or Command Terminal and used as a troubleshooting aid when locating a particular module.
- INPUT** These red indicators (one for each channel) illuminate when an 'ON' condition is sensed.

This panel also includes two operator switches that perform the following:

**COMMISSION** After physical installation and during configuration through CyberStation or Command Terminal, pressing this button registers the module's address with the system. For more information, refer to the section on *Module Configuration* found earlier in this manual.

**RESET** If the module becomes inoperable, pressing this button resets the module. It does not erase its memory.

## DI-8 Digital Input Module

The DI-8, Andover Continuum's digital input module, is used for cost-effective sensing of multiple dry digital inputs in applications such as equipment status monitoring or alarm point monitoring. The DI-8 has eight digital inputs—each can be software configured to accept a digital (contact closure or 0–5 volt input) or counter signal. Counter frequency is 10Hz on all eight inputs. In addition, high speed counting up to 10KHz max. is available (via a DIP switch) on Channels 1 and 2 for high-speed metering and industrial applications.

40V transient suppressors on all eight inputs protect against high voltage short duration transients events. The DI-8 is designed to accept dry contact inputs or 0-5 volts and can withstand up to 24 VAC/DC continuous voltage on four channels.

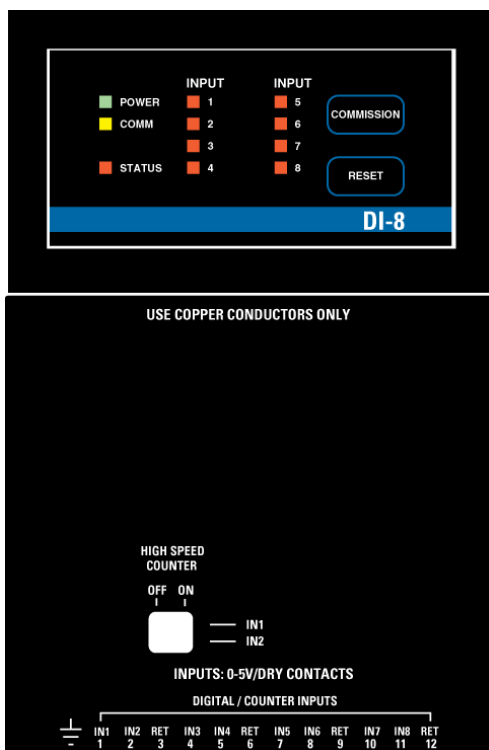

### FEATURES

- Allows interface to relay contact closures or 0–5v digital signals.
- Allows high speed counting on channels 1 and 2.
- Input protection allows accidental wiring of 24VAC to inputs.
- 10–28 V Power Supply Range



## SPECIFICATIONS

### ELECTRICAL

- Power Supply Range:** Input Voltage Range: 10-28V. 24V for UL864 and UL294 installations.
- Power Consumption:** 0.8 Watt (33 mA) @ 24VDC (max.); normally provided by *Andover Continuum* power supply module.
- Overload Protection:** 0.5 A resettable fuse with transient voltage suppressor (TVS) and reverse polarity protection.

### INPUTS

- Number of Inputs:** 8 digital inputs
- Input Types:** Digital or Counter, software selectable
- Input Protection:** 24V AC/DC applied to 4 channels max. (40V transient protection on each input)
- Input Impedance:** 10 K $\Omega$  pull-up resistor referenced to +5V
- Input Connections:** Two-piece, 13-position removable terminal block

#### Digital:

- Input Type:** Contact closure or 0–5V input
- Pulse Width:** 50 ms minimum
- Current:** 0.5 mA

#### Counter:

- Input Type:** Contact closure or 0–5V input

Channels 1 and 2 in HI-speed mode:

- Frequency:** 10 kHz (max.)
- Pulse Width:** 50  $\mu$ s (min.)
- Current:** 0.5 mA

Channels 3 through 8; and Channel 1 and 2 in LO-speed mode:

- Frequency:** 10Hz (max.)
- Pulse Width:** 50 ms (min.)
- Current:** 0.5mA

## I/O Connections

The actual input connections are located on a thirteen-position removable screw terminal connector located at the bottom of the module.

The inputs are labeled IN1, IN2, IN3, and so forth. Each pair of inputs is followed by its return connection labeled RET.

The connector allows for an Earth ground connection, eight inputs and four signal returns.

The diagram screen printed on the module indicates where each input number is located on the terminal block. These connections are also listed below.

Connection	Description
------------	-------------

	Earth Ground
1.	IN 1
2.	IN 2
3.	RETURN
4.	IN 3
5.	IN 4
6.	RETURN
7.	IN 5
8.	IN 6
9.	RETURN
10.	IN 7
11.	IN 8
12.	RETURN

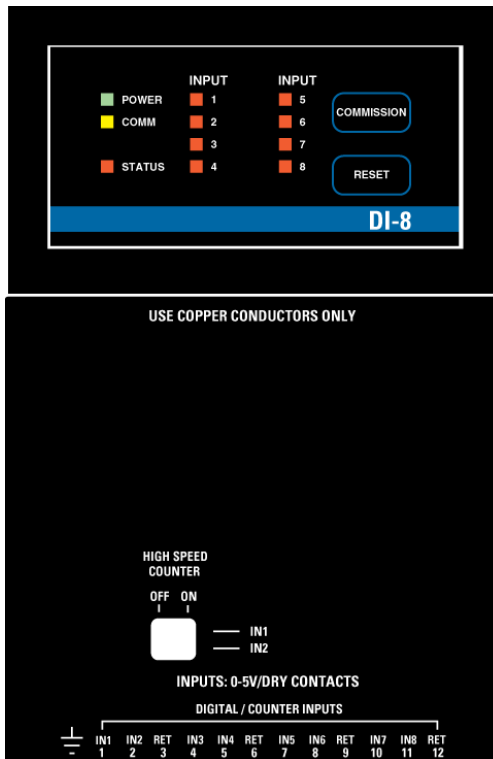

### High Speed Counter Selection Switches

The DI-8 input module allows input channels 1 and 2 to be configured with the capability of counting input pulses or contact closures at a rate of up to 10 kHz. A selection switch is included for each of these two input channels. This switch allows you to select whether or not you want the high speed input connected. A small 2-position switch module is accessible from the front of the module when the door is opened.

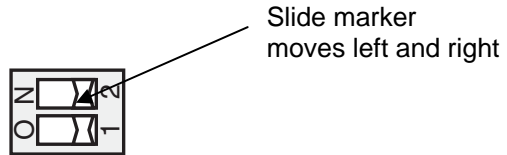

These switch modules are commonly called “DIP Switches” and require a small object such as the tip of a pen or a small screwdriver to operate them. Each switch position acts as a “slide switch”. Pressing the raised slide marker to the left disables high speed counting. To enable high speed counting, move the slide marker over to the right side.

## Input Circuitry

The following is a simplified schematic of the DI-8 Digital Input module:

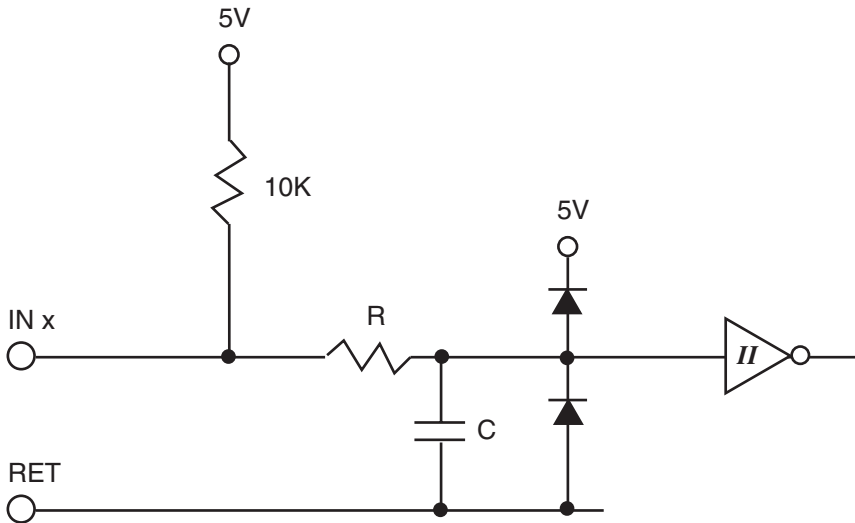

Channels 1 and 2 can be configured to allow high speed counting. The switches on the front of the module substitute different value components for the low pass filter formed by the combination of R and C. These values support higher frequency inputs.

## Sensing Digital Inputs or Contact Closures

Digital input points are designed to provide an ON or OFF reading of a signal (wired between the input and return).

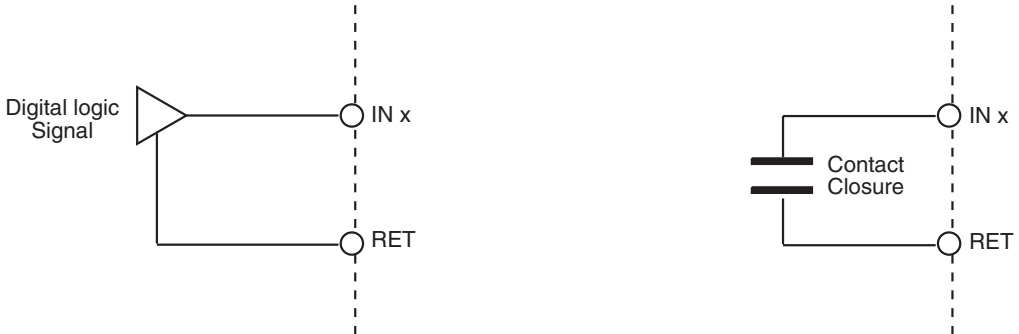

A digital input is considered “ON” whenever the input senses a digital ‘low’ or a contact closure. Similarly, an OFF condition is sensed with a logic ‘high’ or an open contact.

**Note:** When configuring a Digital point, there is a ‘Polarity’ attribute. If this attribute is enabled, readings are reversed.

When configuring this type of input, select:

**ElecType:**                      **Digital**

## Counting Pulsing Signals or Contact Closures

Counter inputs are designed to allow the monitoring of digital pulse trains or contact closures across an input just like digital inputs, but they accumulate a total of those closures and act like a counter.

When using an input as a counter, you must take into account the frequency of the input signal being counted. Inputs 3–8 do not allow for very high speed contact counting. These channels allow counting up to a maximum of 10 Hz or 10 contact closures or digital pulses per second.

In high-speed mode, channels 1 and 2 can be configured (via front panel switch) to count to a maximum of 10 kHz or 10,000 contact closures or digital pulses per second.

When configuring this type of input, select:

**ElecType:**                      **Counter**

## Status/Control Panel

### Status Indicators

The DI-8 module includes a complete indicator status panel on the front of the module.

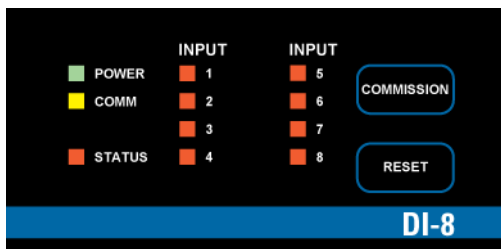

This panel includes indicators reporting on the status of the following:

- POWER** This green indicator illuminates when DC power is applied through the I/O Bus.
- COMM** This yellow indicator illuminates when data is transmitted from the module to the NetController. In normal operation, data is only transmitted when an input value changes.
- This indicator will also flash periodically as the NetController checks the I/O bus.
- STATUS** This red indicator is normally off. If it is always on or flashing at a fast rate there is a problem with the module.
- This indicator can be manually illuminated from the CyberStation workstation or Command Terminal and used as a troubleshooting aid when locating a particular module.
- INPUT** These red indicators (one for each channel) illuminate when an 'ON' condition is sensed.

This panel also includes two operator switches that perform the following:

**COMMISSION** After physical installation and during configuration through the CyberStation workstation or Command Terminal, pressing this button registers the module's address with the system. For more information, refer to the section on *Module Configuration* found earlier in this manual.

**RESET** If the module becomes inoperable, pressing this button resets the module. It does not erase its memory.



## MI-6

### MilliAmp Input Module

The MI-6, Andover Continuum's milliamp input module, allows for a direct connection of a 2-wire, loop powered, 0–20mA or 4–20mA sensor to any of the module's six inputs. The need for an external resistor and an external power supply are eliminated. The MI-6 module is a perfect match for temperature transmitters, humidity and pressure transducers, gas monitors, and other industry-standard sensors with either a 0–20mA or 4–20mA output. The six inputs on the MI-6 module have a 0–20mA range and 10 bit A/D conversion.

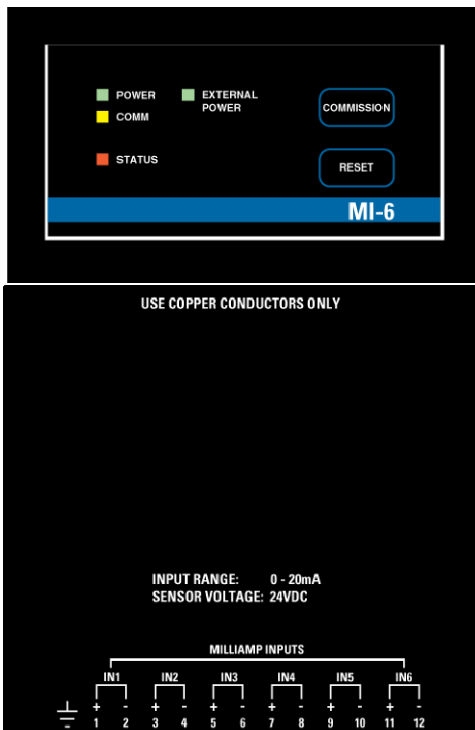

### FEATURES

- 6 Current Measuring Inputs
- 0–20mA Range
- 10 Bit A/D Converter

## SPECIFICATIONS

### ELECTRICAL

**Power Supply Range:** Input Voltage Range: 20-26V. 24V for UL864 installations.  
**Power Consumption:** 3.8 Watts (158 mA) @ 24VDC (max.); normally provided by *Andover Continuum* power supply module (including up to 20mA sensor power for each input).

**Overload Protection:** 0.5 A resettable fuse with transient voltage suppressor (TVS) and reverse polarity protection.

### INPUTS

**Number of Inputs:** 6 Milliamp inputs

**Input Range:** 0–20 mA

**Resolution:** 20  $\mu$ A

**Accuracy:**  $\pm$ 80  $\mu$ A max.

**Drift:**  $\pm$ 50 ppm/DegC (max.)

**Input Resistance:** 249  $\Omega$ , 0.1%

**Maximum Input Current:**  $\pm$ 30 mA

**Voltage Supply to Sensors:** 19.0–26.0V (varies with +24VDC input voltage)

**Input Protection:** Each input and the Sensor voltage output includes a transient voltage suppressor (TVS) and a resettable fuse.













**Input Connections:** Two-piece, 13-position removable terminal block

## I/O Connections

The actual input connections are located on a thirteen-position removable screw terminal connector located at the bottom of the module.

The inputs are labeled IN1, IN2, IN3, and so forth. Each input occupies a pair of terminals, resulting in a sequence of IN1+, IN1-, IN2+, IN2-, and so on. For any given input, observe the polarity for that input, + connects to the Supply terminal of the input. The minus terminal connects to the Signal input.

The diagram below indicates where each input number is located in the terminal block.

Connection	Description
	Earth Ground
1.	IN 1 + 
2.	IN 1 - 
3.	IN 2 + 
4.	IN 2 - 
5.	IN 3 + 
6.	IN 3 - 
7.	IN 4 + 
8.	IN 4 - 
9.	IN 5 + 
10.	IN 5 - 
11.	IN 6 + 
12.	IN 6 - 

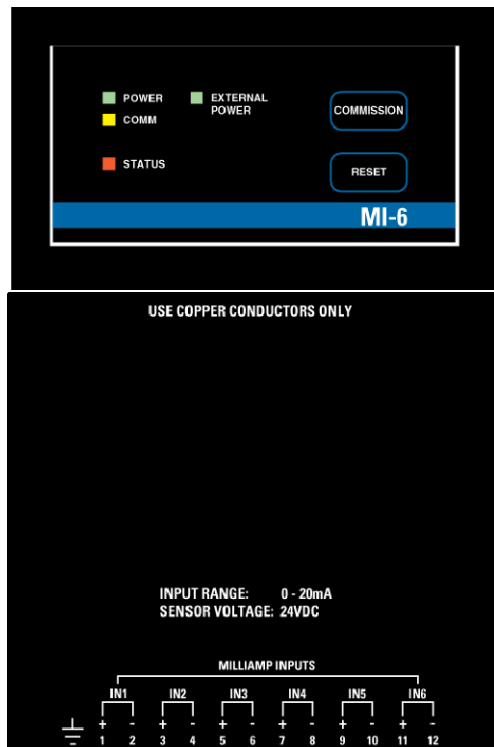

## Input Circuitry

The following is a simplified schematic of the MI-6 Milliamp Input module:

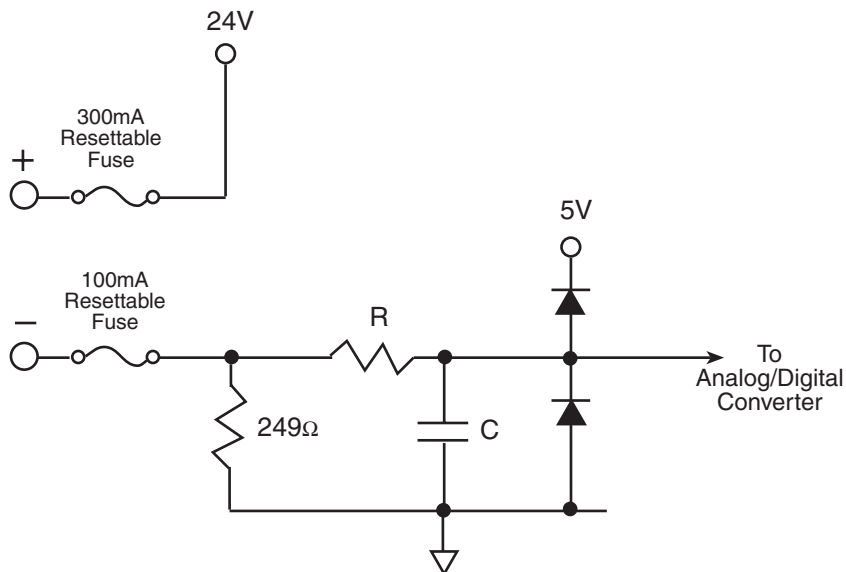

All six input pairs include their own automatically resettable fuses. These devices are designed to open when sensing an over-current. They reset when the current supplied is within range.

**Note:** *In some extreme instances, the fuses may require that you remove power to the module temporarily to reset their state.*

## Sensing Current

The current supplying sensor is connected as indicated in the following illustration:

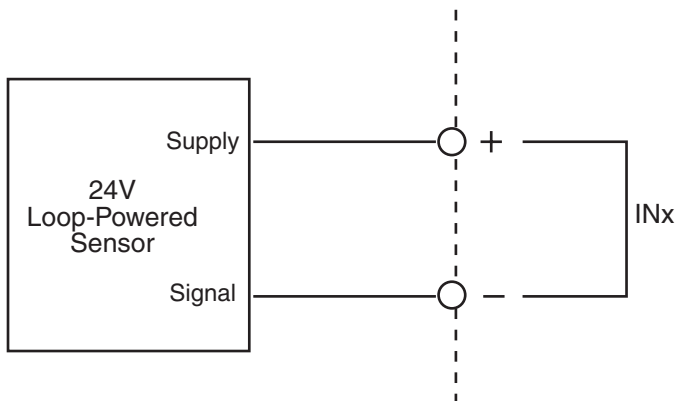

When configuring this type of input, select:

**ElecType:**                    **ACC\_InputCurrent**

## Status/Control Panel

### Status Indicators

The MI-6 module includes a complete indicator status panel on the front of the module.

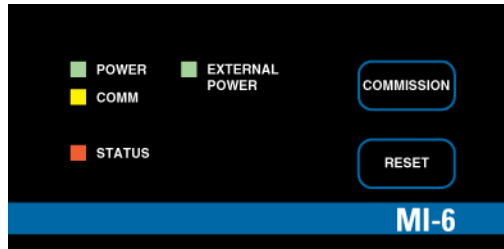

This panel includes indicators reporting on the status of the following:

- POWER** This green indicator illuminates when DC power is applied through the I/O Bus.
- COMM** This yellow indicator illuminates when data is transmitted from the module to the NetController. In normal operation, data is only transmitted when an input value changes.
- This indicator will also flash periodically as the NetController checks the I/O bus.
- STATUS** This red indicator is normally off. If it is always on or flashing at a fast rate, there is a problem with the module.
- This indicator can be manually illuminated from CyberStation or Command Terminal and used as a troubleshooting aid when locating a particular module.
- EXTERNAL POWER** This green indicator illuminates when 24V DC power is available to external sensors.

This panel also includes two operator switches that perform the following:

- COMMISSION** After physical installation and during configuration through the CyberStation workstation or Command Terminal, pressing this button registers the module's address with the system. For more information, refer to the section on *Module Configuration* found earlier in this manual.
- RESET** If the module becomes inoperable, pressing this button resets the module. It does not erase its memory.

## DM-20 Digital Input/Output Module

The DM-20, Andover Continuum’s Digital Input and Output module, provides high density, versatile I/O for many control applications. When coupled with the optional DIO-20 Expansion Board, the DM-20 allows you to mix and match up to 20 digital inputs and outputs. Using standard off-the-shelf digital I/O blocks, the DIO-20 allows the system to meet a wide range of applications, including ON-OFF or pulse-width modulation (PWM) control of equipment and for switching inductive loads up to 240 VAC. The DM-20 provides 24 VDC power to the DIO-20 via a separate cable assembly.

When used without the DIO-20 Expansion Board, the DM-20 can control any combination of inputs and outputs, up to a total of 20 per module.

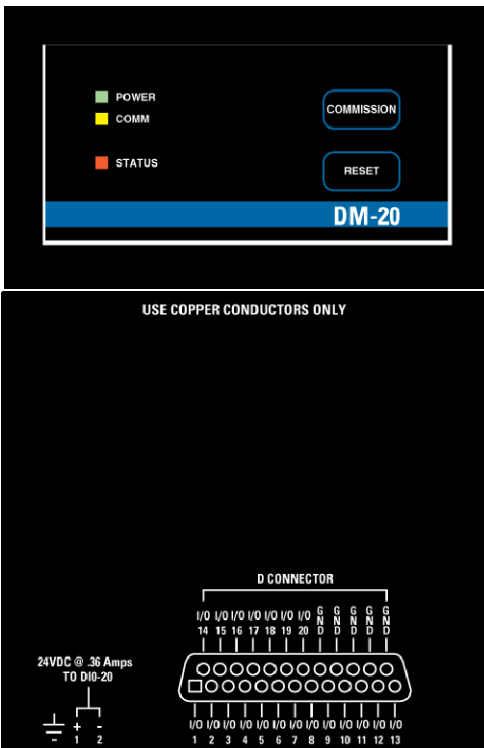

### FEATURES

- 20 General Purpose Digital Inputs/Outputs
- Each point can be configured as an input or an output
- Direct connection to DIO-20 Expansion Module



## SPECIFICATIONS

### ELECTRICAL

<b>Power Supply Range:</b>	Input Voltage Range: 20-26V. 24V for UL864 and UL294 installations.
<b>Power Consumption:</b>	0.5 Watts (20 mA) @ 24VDC (max.); provided by Andover Continuum power supply module. Up to 9 Watts (375 mA) @ 24VDC when the DIO-20 is powered from the DM-20 .
<b>External Power Connector:</b>	Three-position removable connector
<b>Overload Protection:</b>	0.5 A resettable fuse with transient voltage suppressor (TVS) and reverse polarity protection for both DM-20 power and DIO-20 power.
<b>LED Power Supply:</b>	Customer-provided external 5V power supply when using the DM-20 to drive LEDs. <i>For smoke control applications, Schneider Electric power supply: PS 120/240 AC-25 (UL 864 listed) must be used.</i>

### INPUTS/OUTPUTS

20 total points; user-selectable channel-by-channel as inputs or outputs

#### Inputs:

<b>Input Type:</b>	<b>w/DIO-20</b>	<b>w/o DIO-20</b>
	24 VDC logic voltage (DIO-20). Input rating depends on input module(s) selected.	0–5 VDC
<b>Pulse Width:</b>	125 ms (min.)	125 ms (min.)

#### Outputs:

<b>Output Type:</b>	<b>w/DIO-20</b>	<b>w/o DIO-20</b>
	5 VDC logic voltage. Range depends on output module selected.	Open- collector Output transistor with series 330 $\Omega$ 1/8 W resistor; 5 VDC (max.), 15 mA

**Output Resolution:** 0.1 sec. For Pulse Width Modulation (PWM) control

**Output Protection:** Transient voltage suppressor (TVS) and current limiting resistor on each channel.

**I/O Connections:** 25-position DB25 Female and one removable three-terminal block.

## I/O Connections

The actual I/O connections are located on a 25-position DB25-type female connector located at the bottom of the module. A separate three-conductor removable screw connector provides 24 VDC power to external devices.

The inputs are labeled I/O1, I/O2, I/O3, and so forth. Each input/output occupies a single position of the connector. Five signal ground pins are supplied as well.

The diagram below indicates where each input number is located on the DM module.

### 3-Pin Connector

Connection	Description
	Earth Ground
1	+ 24VDC @ .36 Amps
2	24 V Return

### 25-Pin D Connector

Connection	Description
1.	I/O 1
2.	I/O 2
3.	I/O 3
4.	I/O 4
5.	I/O 5
6.	I/O 6
7.	I/O 7
8.	I/O 8
9.	I/O 9
10.	I/O 10
11.	I/O 11
12.	I/O 12
13.	I/O 13
14.	I/O 14
15.	I/O 15
16.	I/O 16
17.	I/O 17
18.	I/O 18
19.	I/O 19
20.	I/O 20
21.	Ground
22.	Ground
23.	Ground
24.	Ground
25.	Ground

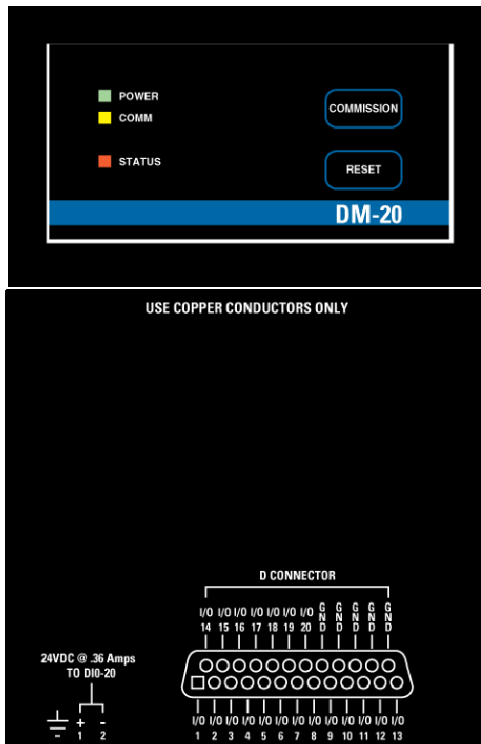

## Input/Output Circuitry

The following is a simplified schematic of each DM-20 Input/Output channel:

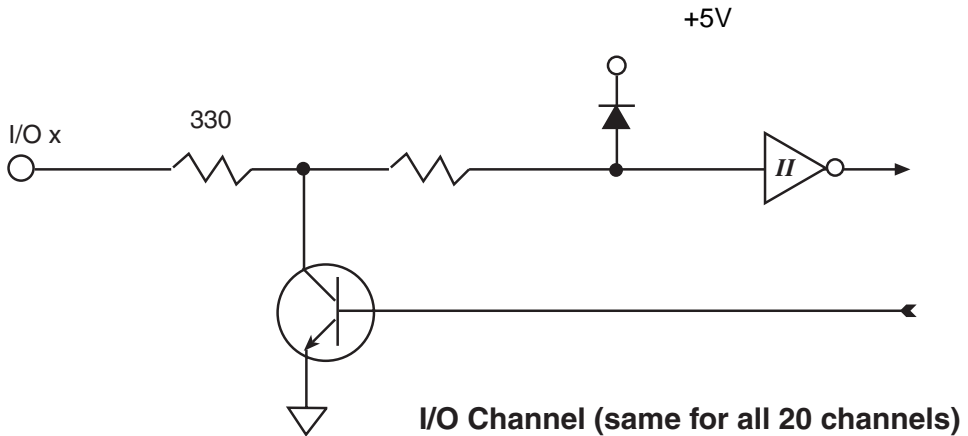

All 20 I/O channels resemble the circuit shown above.

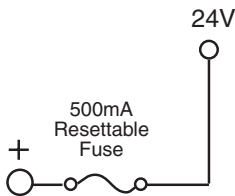

The 24VDC power available to external devices includes an automatically resettable fuse. This fuse is designed to open when an external device tries to extract more current than is available. They reset when the current draw is back within range.

**Note: In some extreme instances, the fuses may require that you remove power to the module temporarily to reset their state.**

## Using the DM-20

The DM-20 is primarily designed to directly interface with the DIO-20. However, it can also be used as a general purpose digital I/O module containing 20 points.

**Note: Make sure that external devices are attached to the DM-20 before powering the unit.**

### DIO-20 Interface

The DIO-20 Expansion Module provides a connection for up to 20\* solid state input or output modules for the I/O channels of the DM-20. It includes individually fused sockets for modules from manufacturers such as Opto 22, Grayhill, Gordos, Crydom and Potter & Brumfield. You can mix input and output modules on the DIO-20 as needed.

The connection between the DM-20 and the DIO-20 consists of a 25-pin ribbon cable to supply data between the modules and a two-conductor power cable.

Data connection between the two is accomplished via a 25-pin male-male DB25 cable:

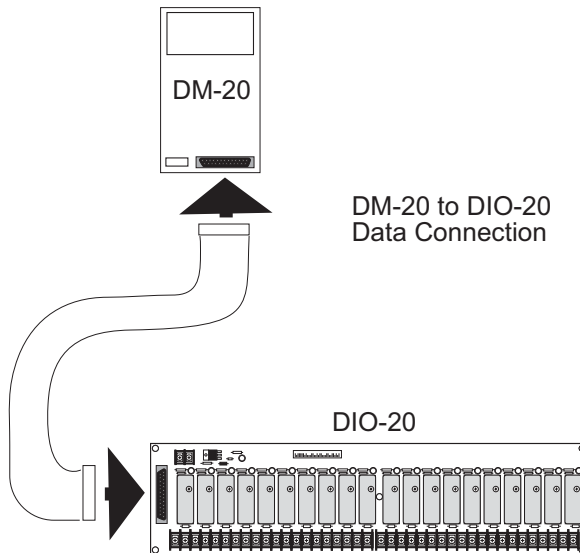

\*The actual number of modules supported depends on type and power used. Refer to the power requirements on page 86.

The Power connection between the DIO-20 and the DM-20 is via a two-conductor cable assembly as shown:

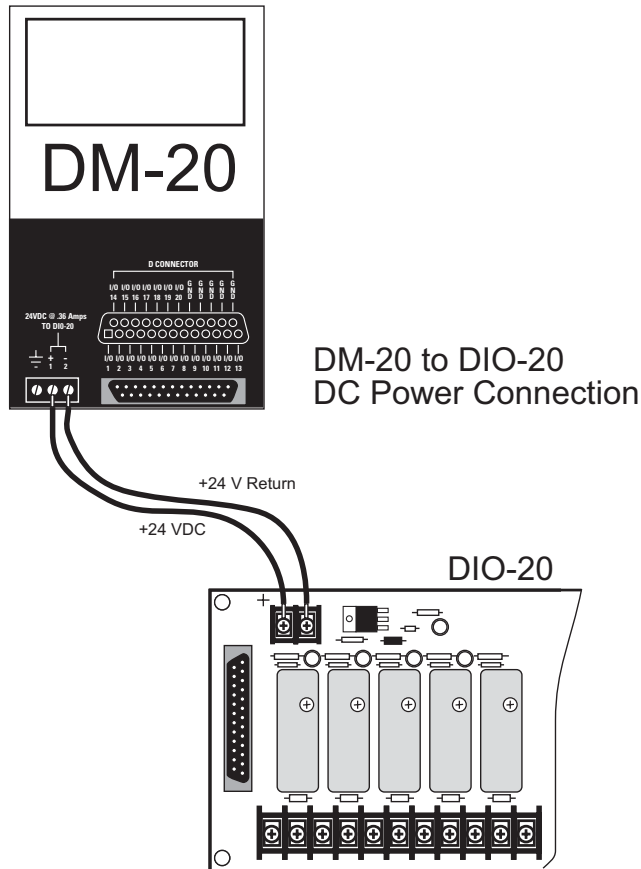

### Using the DM-20/DIO-20 Combination

The DIO-20 provides the DM-20 with a real-world interface to its I/O channels. Solid-state input modules (on the DIO-20) provide interface circuitry to a variety of signals. These modules convert their signals to digital levels for input to the DM-20.

Similarly, solid-state output modules (on the DIO-20) allow the digital levels of the DM-20 to interface to a variety of signals.

In both cases, the I/O points are set up to have an Electrical Type of **Digital** no matter what type of solid-state module is installed.

## General Purpose DM-20 Digital Interface

The DM-20 can be used to provide 20\* general purpose digital inputs and outputs. It is not necessary to interface the module with an external expansion product to use its capabilities. Each channel can be used to output a digital signal or read a digital signal or contact closure.

The DM-20 can be configured as a general purpose digital input. With the addition of an external reference pull-up resistor, it can be used for sensing contact closures or digital logic signals as shown below:

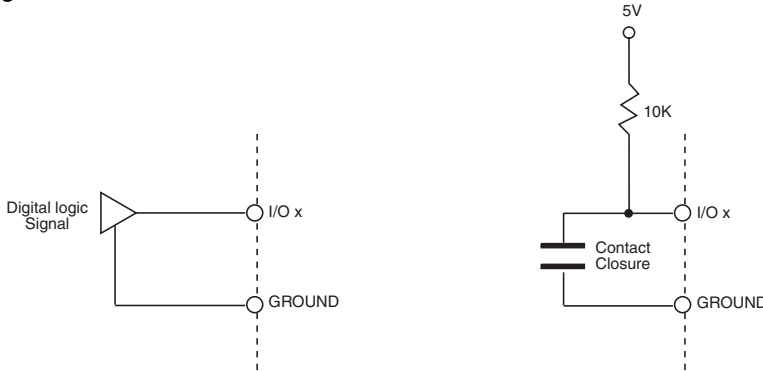

As a digital output, the DM-20 has an open collector output with a 330 Ω series resistor. Connect digital devices and LED indicators as shown below:

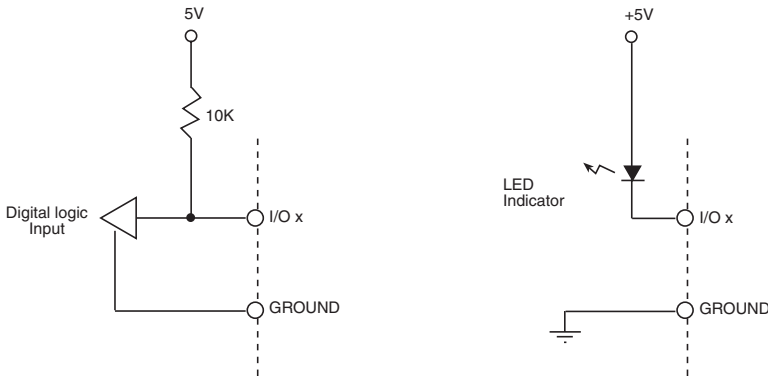

When configuring any of these inputs/outputs, select:

**ElecType: Digital**

\* The actual number of modules supported depends on type and power used. Refer to the power requirements on the following page.

## Loss of Power / Communication Output Restore Time

When power is lost to the module, all outputs turn off. This also occurs when the module has lost communication with the NetController for more than 255 seconds.

When power is finally restored, the module can immediately restore the last state of the outputs or be delayed so that the NetController can update the state before energizing them. This option is called **Output Restore Time** and its value can be set through a Numeric.

The Output Restore Time numeric is configured as follows:

Function	Channel	Object Type	Direction	Values
Output Restore Time	21	Numeric	IOOutput	Number of seconds to wait before restoring output state: 0–255

If the Output Restore Time numeric is not defined, the output will restore immediately upon return of I/O power.

**NOTE:** Pulsed values are "saved" and will occur in their entirety after delay.

## DM-20/DIO-20 Module Power Requirements

The DM-20 includes the ability to directly power a DIO-20 module. DIO-20 modules support a combination of up to 20 input and output modules. The following details the power requirements of each combination. This information is presented to determine the power supply requirements for the board.

- Input modules consume a maximum current in their ON state of 23mA. **The DM-20 can only supply enough power for 14 input modules.**
- Output modules consume a maximum current in their ON state of 16mA.
- The DIO-20 itself without any modules installed draws 20mA.

The DM-20 provides a total of 360mA for the DIO-20. Using the numbers supplied above you can calculate how many modules are allowed.

### Examples:

Up to 14 input modules:  $(14 \times 23\text{mA}) + 20\text{mA} = 342\text{mA}$

A total of 14 input modules exhausts (with only 18mA remaining) the current capability of the DM-20.

Up to 20 output modules:  $(20 \times 16\text{mA}) + 20\text{mA} = 340\text{mA}$

A total of 20 output modules consumes only 340mA from the DM-20.

## Status/Control Panel

### Status Indicators

The DM-20 module includes a complete indicator status panel on the front of the module.

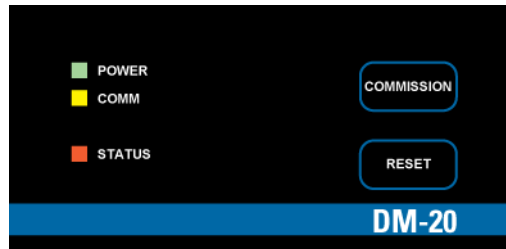

This panel includes indicators reporting on the status of the following:

- POWER** This green indicator illuminates when DC power is applied through the I/O Bus.
- COMM** This yellow indicator illuminates when data is transmitted from the module to the NetController. In normal operation, data is only transmitted when an input value changes.
- This indicator will also flash periodically as the NetController checks the I/O bus.
- STATUS** This red indicator is normally off. If it is always on or flashing at a fast rate, there is a problem with the module.
- This indicator can be manually illuminated from CyberStation or Command Terminal and used as a troubleshooting aid when locating a particular module.



This panel also includes two operator switches that perform the following:

- COMMISSION** After physical installation and during configuration through the CyberStation workstation or Command Terminal, pressing this button registers the module's address with the system. For more information, refer to the section on *Module Configuration* found earlier in this manual.
- RESET** If the module becomes inoperable, pressing this button resets the module. It does not erase its memory.

## AO-4-8, AO-4-8-O Analog Output Modules

The AO-4-8, Andover Continuum’s analog output module, has four analog outputs with eight-bit resolution, which can be configured as either voltage (0-10 VDC) or current (0-20 mA) outputs. The AO-4-8 is the perfect choice for valves, dampers, variable speed drives, and similar equipment that demand high control accuracy.

An AO-4-8-O model with full override capabilities is also available. Each output contains a three-position manual override switch and override potentiometer. In addition, the AO-4-8-O provides software override feedback to the Plain English programming language for each output.

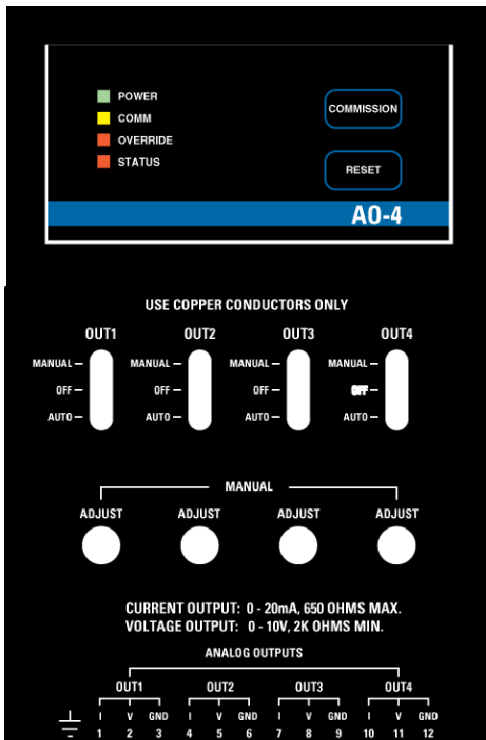

### FEATURES

- 4 Analog Outputs
- 8 bit Resolution
- 0–10V Voltage Outputs
- 0–20mA Current Outputs

#### **AO-4-8-O Only:**

- Override Toggle Switches and Potentiometers
- Override Detection

## SPECIFICATIONS

### ELECTRICAL

<b>Power Supply Range:</b>	Input Voltage Range: 20-26V. 24V for UL864 installations.
<b>Power Consumption:</b>	3.8 Watts (158 mA) @ 24VDC (max.); normally provided by Andover Continuum power supply module.
<b>Overload Protection:</b>	0.5 A resettable fuse with transient voltage suppressor (TVS) and reverse polarity protection.

### OUTPUTS

<b>AO-4-8:</b>	4 analog outputs; 8 bit resolution
<b>AO-4-8-O:</b>	4 analog outputs with overrides; 8 bit resolution
<b>Output Protection:</b>	1/8 pico fuse per channel (40V TVS on each output—AO-4-8-O model only)
<b>Output Connections:</b>	Two-piece, 13-position removable terminal block
<b>Output Types:</b>	Voltage or current
<b>Voltage:</b>	
<b>Range:</b>	0–10 V
<b>Resolution:</b>	0.05 V
<b>Accuracy:</b>	±0.10V (1%FSR)
<b>Output Current:</b>	+5 mA (sourcing) -1 mA (sinking)
<b>Load Resistance:</b>	2 K $\Omega$ min.(sourcing)
<b>Current:</b>	
<b>Range:</b>	0–20 mA
<b>Resolution:</b>	0.1 mA
<b>Accuracy:</b>	±0.2 mA
<b>Load Resistance:</b>	650 $\Omega$ (max.)
<b>Output Overrides:</b> (AO-4-8-O only)	3-position manual override switch and override potentiometer on each output, with software feedback. LED override status indicator.
<b>Output Connections:</b>	Two-piece, 13-position removable terminal block

## I/O Connections

The actual output connections are located on a thirteen-position removable screw terminal connector located at the bottom of the module.

The outputs are labeled OUT1 I, OUT1 V, OUT1 GND, and so forth. Each output presents two ways of connecting, resulting in a current output between OUT1 I and OUT1 GND, and a voltage output between OUT1 V and OUT1 GND.

The connector allows for an Earth ground connection, eight inputs and four signal returns.

The diagram screen printed on the module indicates where each input number is located on the terminal block. These connections are also listed below.

Connection	Description
------------	-------------

	Earth Ground
1.	OUT1 I
2.	OUT1 V
3.	OUT1 GND
4.	OUT2 I
5.	OUT2 V
6.	OUT2 GND
7.	OUT3 I
8.	OUT3 V
9.	OUT3 GND
10.	OUT4 I
11.	OUT4 V
12.	OUT4 GND

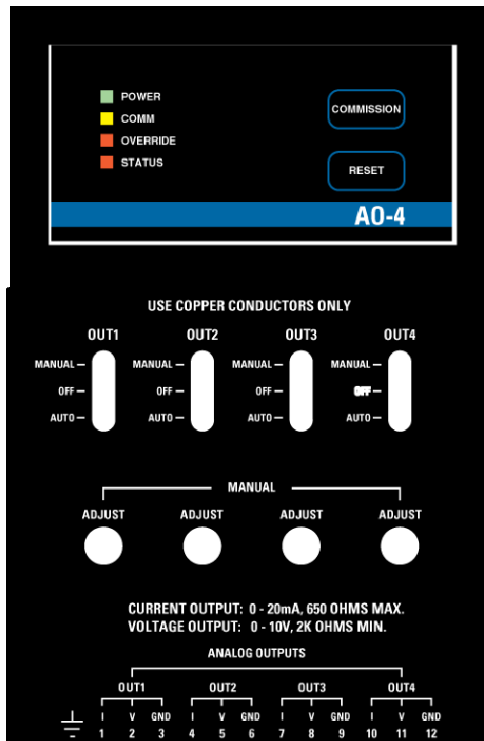

## Output Circuitry

The following is a simplified schematic of each AO-4-8 Output channel:

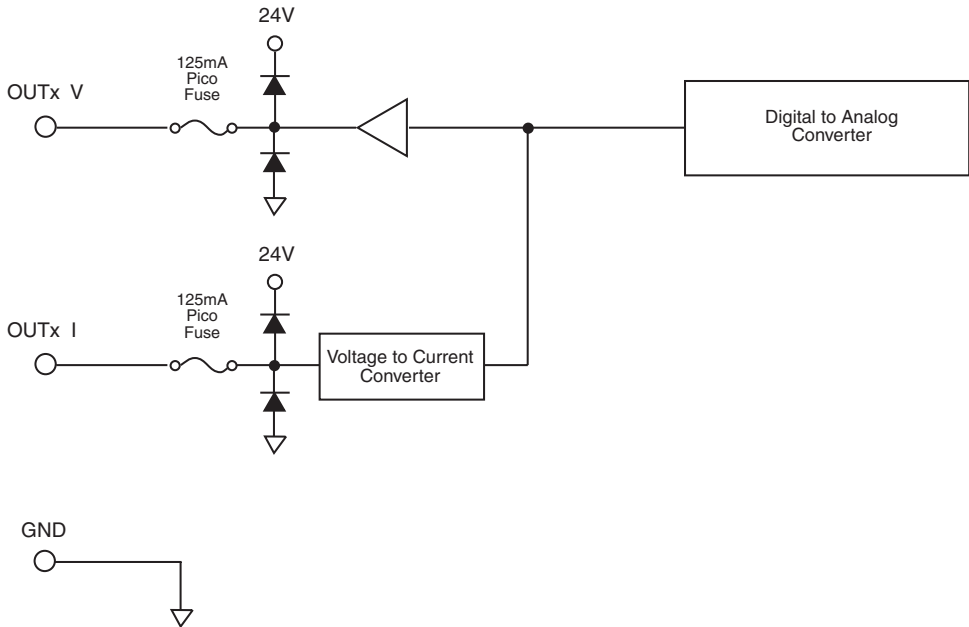

All 4 channels resemble the circuit shown above.

## Override Controls

The AO-4-8-O model includes an output override switch and manual variable control for each output.

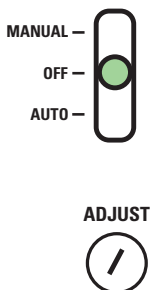

The following describes the actions associated with each position of the override controls:

- MANUAL** The analog signal generated by the module is controlled manually by adjusting the ADJUST potentiometer below to the manual override switch. Programs have no effect on the output when the switch is in this position.
- OFF** The output is set to zero volts, zero mA. Programs and the setting on the ADJUST potentiometer have no effect on the output Device when the switch is in this position.
- AUTO** The analog signal is generated as a direct result of program control. The setting on the ADJUST potentiometer has no effect on the output Device when the switch is in this position.
- ADJUST** This is a variable control that allows you to manually adjust the output of the analog signal when the override switch is in the MANUAL position. Insert the tip of a small screwdriver to use this control. Turning to the right (clockwise) increases the output. Turning left (counterclockwise) decreases the output.

## Voltage Output

The voltage output is a ground-referenced signal with a range of 0–10 VDC. The maximum output current is 5 mA (2,000  $\Omega$  s minimum resistance). Ensure that the device being connected is either floating or at the same ground potential as the controller.

Connect the device across the following terminals:

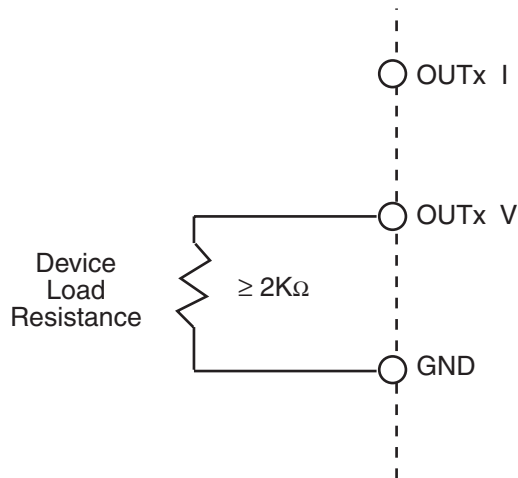

**NOTE:** The load resistance (of the external device) must be greater than or equal to  $2K\Omega$ .

When configuring this type of output, select:

**ElecType:**                      **Voltage**

## Current Output

The current output is a current-sourcing, ground referenced circuit. This output can source 0 - 20 mA with a maximum load impedance of 650  $\Omega$ . Connect the device across the following terminals:

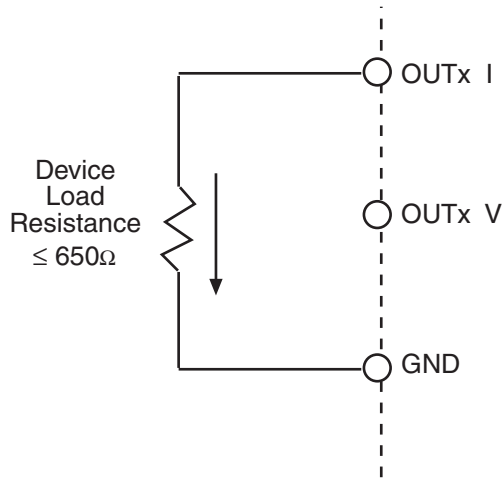

**NOTE:** The load resistance (of the external device) must be less than or equal to 650  $\Omega$ .

When configuring this type of output, select:

**ElecType:**                      **Current**



## Status/Control Panel

### Status Indicators

The AO-4-8 module includes a complete indicator status panel on the front of the module.

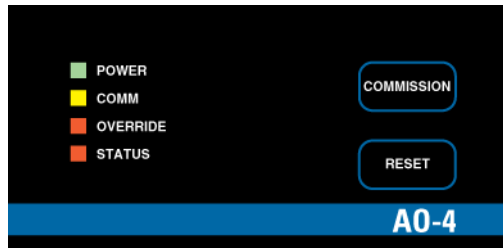

This panel includes indicators reporting on the status of the following:

- |                 |   |
|-----------------|---|
| <b>POWER</b>    | This green indicator illuminates when DC power is applied through the I/O Bus.  |
| <b>COMM</b>     | This yellow indicator illuminates when data is transmitted from the module to the NetController. In normal operation, data is only transmitted when an input value changes.<br><br>This indicator will also flash periodically as the NetController checks the I/O bus.                             |
| <b>STATUS</b>   | This red indicator is normally off. If it is always on or flashing at a fast rate, there is a problem with the module.<br><br>This indicator can be manually illuminated from the CyberStation workstation or Command Terminal and used as a troubleshooting aid when locating a particular module. |
| <b>OVERRIDE</b> | This red indicator illuminates whenever any of the override switches is in a position other than AUTO.  |

This panel also includes two operator switches that perform the following:

- COMMISSION** After physical installation and during configuration through the CyberStation workstation or Command Terminal, pressing this button registers the module's address with the system. For more information, refer to the section on *Module Configuration* found earlier in this manual.
- RESET** If the module becomes inoperable, pressing this button resets the module. It does not erase its memory.

## DO-4-R, DO-4-R-O Digital Output Module

The DO-4-R, Andover Continuum's digital output module, has four Form C relay outputs, rated at 5 Amps @240 VAC. These versatile outputs make the DO-4-R an excellent choice for switching motor starters and other inductive loads up to 240 VAC, with either two position (on/off) or Pulse-Width Modulation (PWM) control. The PWM feature permits the modulation of valves and dampers to 0.1 second resolution. Two adjacent Form C relay outputs can be combined in software to provide a Tri-state output, for bi-directional control of valves and dampers and other end devices. Metal oxide varistors and 5000V isolation on each output ensure reliable noise-free operation.

A DO-4-R-O model with full override capabilities is also available. Each output has a local hand-off-auto switch, which enables service personnel to override the output. The switch also provides override feedback of output values for use in troubleshooting or test conditions. A local indicator light for each output displays relay status. Another LED provides override status.

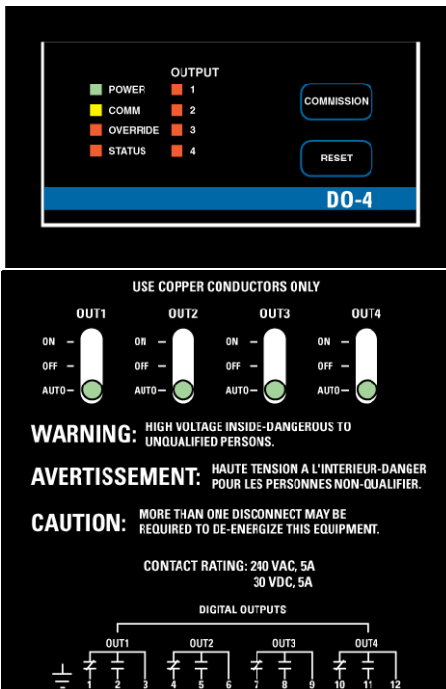

### FEATURES

- 4 Form C Relay Outputs
- 240 VAC @ 5A Contact Rating
- Independently Mounted
- Output Status LEDs
- 10–28 V Power Supply Range

### *DO-4-R-O Only:*

- Override Toggle Switches
- Override Detection

## SPECIFICATIONS

### ELECTRICAL

<b>Power Supply Range:</b>	(DO-4-R, DO-4-R-O): Input Voltage Range: 10-28V. 24V for UL864 and UL294 installations.
<b>Power Consumption:</b>	2.8 Watts (116 mA) @ 24 VDC (max.); normally provided by Andover Continuum power supply module.
<b>Overload Protection:</b>	0.5 A resettable fuse with transient voltage suppressor (TVS) and reverse polarity protection.

### OUTPUTS

<b>DO-4-R:</b>	4 Form C relay outputs
<b>DO-4-R-O:</b>	4 Form C relay outputs with overrides
<b>Output Rating:</b>	240 VAC @ 5 Amps; 30 VDC @ 5 Amps
<b>Output Resolution:</b>	0.1 sec. For Pulse Width Modulation (PWM) control
<b>Output Protection:</b>	270 V varistors across contacts. 5000 VRMS isolation @ 60 Hz between relay contacts and relay coil.
<b>DO-4-R-O Output Overrides:</b>	3-position manual override switch on each output, with software feedback. LED override status indicator
<b>DO-4-R-O Override Feedback:</b>	Override detection and feedback provided for each output.
<b>Output Connections:</b>	Two-piece, 13-position removable terminal block

### EUROPEAN STANDARDS

European Multi-Purpose Control–Electronic  
Type 1B–Micro Disconnect

## I/O Connections

The actual output connections are located on a thirteen-position removable screw terminal connector located at the bottom of the module.

The outputs are labeled OUT 1 NC, OUT 1 NO, OUT 1 COM, and so forth. Each output presents a single pole double throw set of contacts. OUT 1 NC is the normally closed side of the contact. OUT 1 NO is the normally open contact. OUT 1 COM is the common connection that represents the armature of the relay switch.

The diagram below indicates where each output number is located in the terminal block.

Connection	Description
	Earth Ground
1.	OUT 1 NC
2.	OUT 1 NO
3.	OUT 1 COM
4.	OUT 2 NC
5.	OUT 2 NO
6.	OUT 2 COM
7.	OUT 3 NC
8.	OUT 3 NO
9.	OUT 3 COM
10.	OUT 4 NC
11.	OUT 4 NO
12.	OUT 4 COM

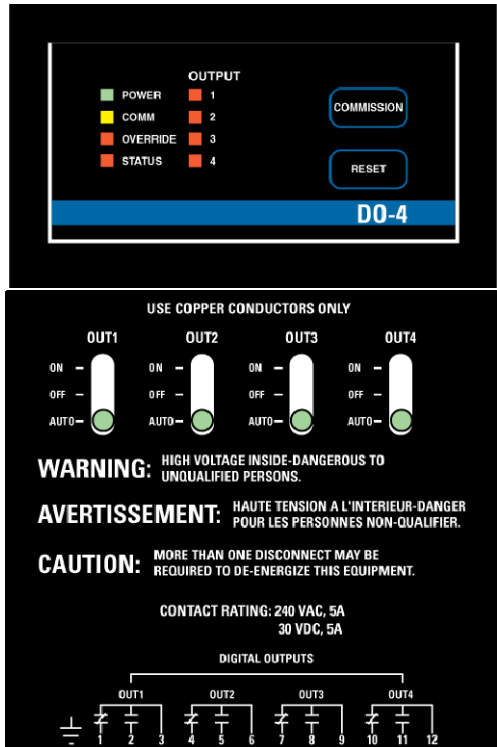

## Output Circuitry

The following is a simplified schematic of each Output channel:

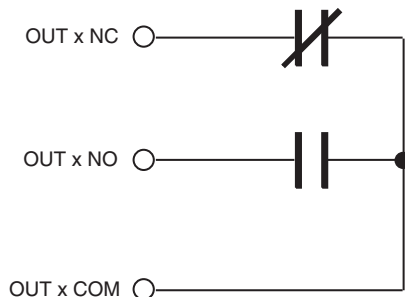

All 4 channels resemble the circuit shown above.

These output contacts operate as a standard relay. When the output is set to an “ON” state, the normally open contacts (OUTx NO) close and the normally closed contacts (OUTx NC) open.

To use the Form C output in your system, configure an output point with an Electrical Type of **Digital**.

### Supervising the Outputs for UL1076

To supervise the operation of the DO-4 outputs, install a remote relay in parallel with the device being switched. The contacts of this relay are connected back to a UI-8 supervised input. A 10K EOL resistor is connected across the relay contacts. A Plain English program containing the following line would be executed:

```
If (DO4_Output = On AND UI8_Input = Off) OR (UI8_Input = TROUBLE) THEN
DO4_Alarm = ON ELSE DO4_Alarm = OFF
```

If an open, short or grounded condition exists either on the cable out to the switched device or the cable running back to the UI-8, an audio and visual alarm would be triggered at the central receiving station when the output was turned on.

For 24 VDC Loads use relay: Potter & Brumfield (TYCO) KUP5D15 \*

For 24 VAC loads use relay: Potter & Brumfield (TYCO) KUP5A15 \*

\*These relays are UL recognized components

## Override Controls

The DO-4-R-O model includes an output override switch for each output.

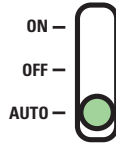

The output of the module can be directed from program control to manual control. The output can be disabled completely as well.

The following describes the actions associated with each position of the override controls:

- ON** The output relay is energized to an “ON” state manually by setting the switch to ON. Programs have no effect on the output when the switch is in this position.
- OFF** The output relay is de-energized to an ‘OFF’ state manually by setting the switch to OFF. Programs have no effect on the output when the switch is in this position.
- AUTO** The action of the output relay is determined as a direct result of program control.

## Loss of Power / Communication: Output Restore Time

When power is lost to the module or it loses contact with the NetController for more than 255 seconds, all outputs turn off. When power is finally restored, the module can immediately restore the last state of the outputs or be delayed so that the NetController can update the state before energizing them. This option is called Output Restore Time and its value can be set through a Numeric.

The Output Restore Time numeric is configured as follows:

Function	Channel	Object Type	Direction	Values
Output Restore Time	5	Numeric	IOOutput	Number of seconds to wait before restoring output state: 0-255

If the Output Restore Time numeric is not defined, the output will restore immediately upon return of I/O power.

## Tri-State Output

Although the module contains four separate form C relays, adjacent pairs of these can be combined at any one time to form a standard Tri-state output:

OUT1 and OUT2

OUT3 and OUT4

Configure the output point of the first point (OUT1 or OUT3) with an Electrical Type of **Tri-state**.

**Caution: Do not attempt to use OUT2 and OUT3 as a tri-state pair. An error message may result. Configure tri-state outputs as OUT1-OUT2 or OUT3-OUT4.**

Connect the two outputs together as follows (example shows OUT1 and OUT2):

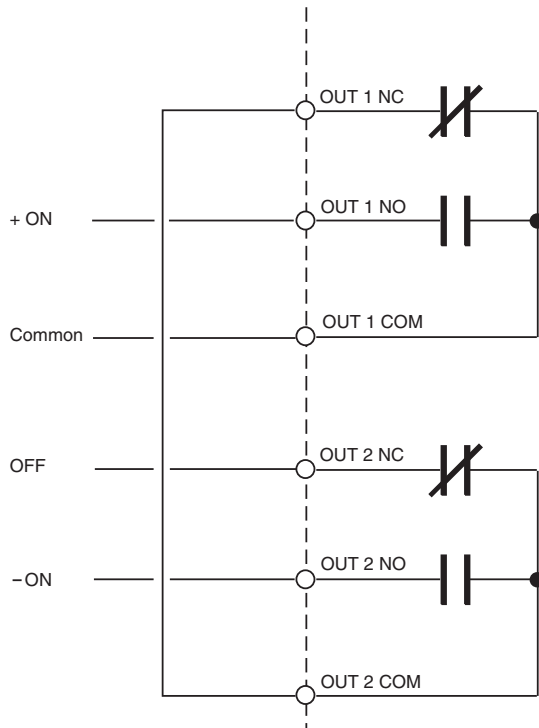



## Status/Control Panel

### Status Indicators

All DO-4 models include a complete indicator status panel on the front of the module.

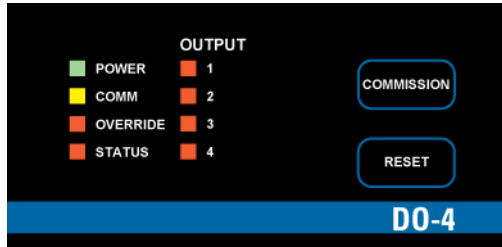

This panel includes indicators reporting on the status of the following:

- POWER** This green indicator illuminates when DC power is applied through the I/O Bus.
- COMM** This yellow indicator illuminates when data is transmitted from the module to the NetController. In normal operation, data is only transmitted when an input value changes.
- This indicator will also flash periodically as the NetController checks the I/O bus.
- OVERRIDE** This red indicator illuminates whenever any of the override switches is in a position other than AUTO. (operates on -O models only)
- STATUS** This red indicator is normally off. If it is always on or flashing at a fast rate, there is a problem with the module.
- This indicator can be manually illuminated from CyberStation or Command Terminal and used as a troubleshooting aid when locating a particular module.
- OUTPUT** These red indicators (one for each channel) illuminate when an output relay is energized.

This panel also includes two operator switches that perform the following:

**COMMISSION** After physical installation and during configuration through CyberStation or Command Terminal, pressing this button registers the module's address with the system. For more information, refer to the section on *Module Configuration* found earlier in this manual.

**RESET** If the module becomes inoperable, pressing this button resets the module. It does not erase its memory.

## DO-6-TR Triac Output Module

The DO-6-TR, Andover Continuum's triac output module, has six Form A triac-based outputs, rated at 0.5 Amps @ 24 VAC, for cost-effective on/off or pulse-width modulation (PWM) control of lighting, heat, and fan units. The PWM feature permits the modulation of valves and dampers to 0.1 second resolution. Adjacent outputs can also be configured in pairs to provide up to three Form K, Tri-state outputs for bi-directional control of dampers and valves.

Metal Oxide Varistors (MOVs), Snubbers and Optocouplers on the DO-6-TR provide 2500 V isolation on each output, ensure noise-free operation, and, in most cases, eliminate the need to install MOVs in the field.

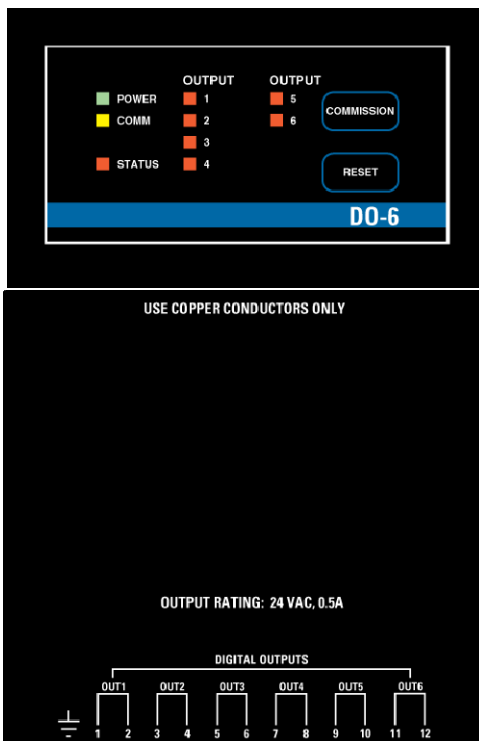

### FEATURES

- Six (6) Triac-based outputs
- 24 Vrms @ 0.5 A Contact Rating
- Output Status LEDs

## SPECIFICATIONS

### ELECTRICAL

<b>Power Supply Range:</b>	Input Voltage Range: 20-26V. 24V for UL864 installations.
<b>Power Consumption:</b>	1.1 Watts (45 mA) @ 24 VDC (max.); normally provided by Andover Continuum power supply module.
<b>Overload Protection:</b>	0.5 A resettable fuse with Transient Voltage Suppressor (TVS) and reverse polarity protection.

### OUTPUTS

<b>Output Type:</b>	6 Form A optically isolated triac outputs (can be configured up to 3 Form K Tri-State outputs)
<b>Output Rating:</b>	0.5A @ 24 VAC, (Cannot switch DC loads)
<b>Output Accuracy:</b>	0.1 sec. for Pulse Width Modulation (PWM) control
<b>Output Protection:</b>	2500 V optical isolation MOV and Snubber on each output
<b>Output Connections:</b>	Two-piece, 13-position removable terminal block

## I/O Connections

The actual output connections are located on a thirteen-position removable screw terminal connector located at the bottom of the module.

The outputs are grouped in pairs of two connector terminals per channel. Each output presents a normally open single pole set of contacts.

The diagram below indicates where each output number is located in the terminal block.

Connection	Description
	Earth Ground
1.	OUT 1
2.	OUT 1
3.	OUT 2
4.	OUT 2
5.	OUT 3
6.	OUT 3
7.	OUT 4
8.	OUT 4
9.	OUT 5
10.	OUT 5
11.	OUT 6
12.	OUT 6

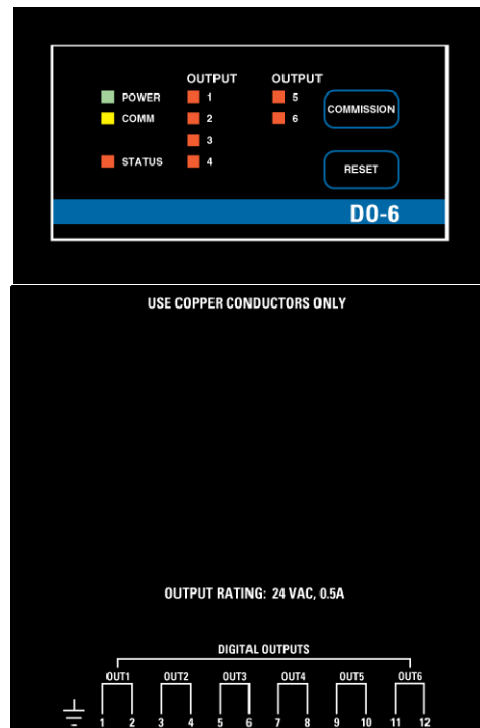

## Output Circuitry

The following is a simplified schematic of each DO-6-TR Output channel:

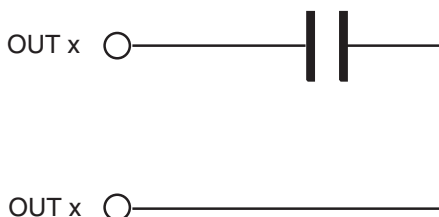

All 6 channels resemble the circuit shown above.

These output contacts operate as a solid state relay. When the output is set to an “ON” state, the contacts close allowing current to flow between the output terminals.

To use the Form A output in your system, configure an output point with an Electrical Type of ***Digital***.

### Loss of Power / Communication: Output Restore Time

When power is lost to the module or it loses contact with the NetController for more than 255 seconds, all outputs turn off. When power is finally restored, the module can immediately restore the last state of the outputs or be delayed so the NetController can update the state before energizing them. This option is called **Output Restore Time** and its value can be set through a Numeric.

The Output Restore Time numeric is configured as follows:

Function	Channel	Object Type	Direction	Values
Output Restore Time	7	Numeric	IOOutput	Number of seconds to wait before restoring output state: 0-255

If the Output Restore Time numeric is not defined, the output will restore immediately upon return of I/O power.

## Switching Loads with Triacs

Although the Triac-based outputs of this module appear as relay contacts in the schematics provided, they are actually solid-state switches that have limitations on the loads they can switch.

### AC vs. DC

The first limitation is that they cannot be used with DC loads. ***A Triac switches AC only.***

### Minimum Load Current

The second limitation involves the minimum load current. ***In order for the Triac to switch, it must detect at least 30 mA of current from the load.*** If your load is less than 30 mA, you can induce the required load by connecting a resistor across the load (not directly at the Triac!). Check the current draw specification on your field device, and if it does not meet this minimum, add a resistor in parallel with the device being driven sized to achieve the minimum loading. Use the following formulas to determine resistance and wattage:

$$\text{Resistance } (\Omega\text{s}) = \frac{\text{Voltage}}{\text{Current}}$$

$$\text{Power (Watts)} = \frac{(\text{Voltage})^2}{\text{Resistance}}$$

## Tri-State Output

Although the module contains six separate form A relays, adjacent pairs of these can be combined at any one time to form a standard Tri-state output:

OUT1 and OUT2

OUT3 and OUT4

OUT5 and OUT6

Configure the output point of the first point (OUT1, OUT3 or OUT5) with an Electrical Type of **Tri-state**.

**Caution:** Do not attempt to use OUT2 and OUT3 or OUT4 and OUT5 as a tri-state pair. An error message may result. Configure tri-state outputs as OUT1-OUT2, OUT3-OUT4 or OUT5-OUT6.

Connect two outputs together to form a tristate output as follows (pair OUT1 and OUT2 is shown):

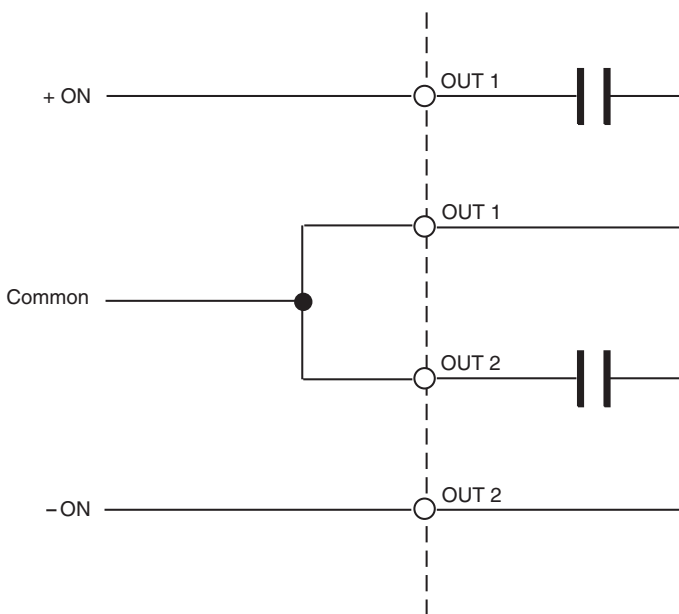



## Status/Control Panel

### Status Indicators

The DO-6-TR module includes a complete indicator status panel on the front of the module.

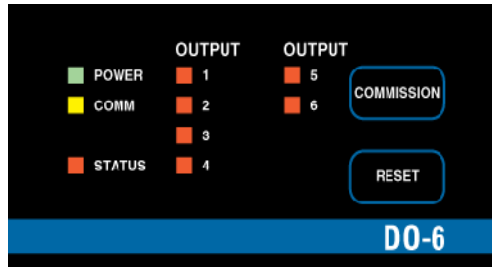

This panel includes indicators reporting on the status of the following:

- POWER** This green indicator illuminates when DC power is applied through the I/O Bus.
- COMM** This yellow indicator illuminates when data is transmitted from the module to the NetController. In normal operation, data is only transmitted when an input value changes.
- This indicator will also flash periodically as the NetController checks the I/O bus.
- STATUS** This red indicator is normally off. If it is always on or flashing at a fast rate, there is a problem with the module.
- This indicator can be manually illuminated from the CyberStation workstation or Command Terminal and used as a troubleshooting aid when locating a particular module.
- OUTPUT** These red indicators (one for each channel) illuminate when a triac output is ON.

This panel also includes two operator switches that perform the following:

- COMMISSION** After physical installation and during configuration through the CyberStation workstation or Command Terminal, pressing this button registers the module's address with the system. For more information, refer to the section on *Module Configuration* found earlier in this manual.
- RESET** Should the module become inoperable, pressing this button resets the module. It does not erase its memory.

## LO-2, LO-2-O Lighting Control Module

The LO-2, Andover Continuum’s lighting control module, can control 2 high voltage lighting circuits, using externally mounted GE RR7 or RR9 lighting relays, rated for 277 VAC and 20 Amps (347 VAC option for Canada). The RR9 relay provides status feedback of the relay position, using a built-in pilot contact. The RR7 relay provides control of the circuit with no feedback. An on-board status LED for each output is provided when RR9 relays are used, as well as pilot light voltage for wall switches that have status indication. External 28 VAC is required to power the GE relays. This same transformer can power the LO-2 when the module is located remotely.

An LO-2-O model, with on-board momentary override toggle switches, is also available.

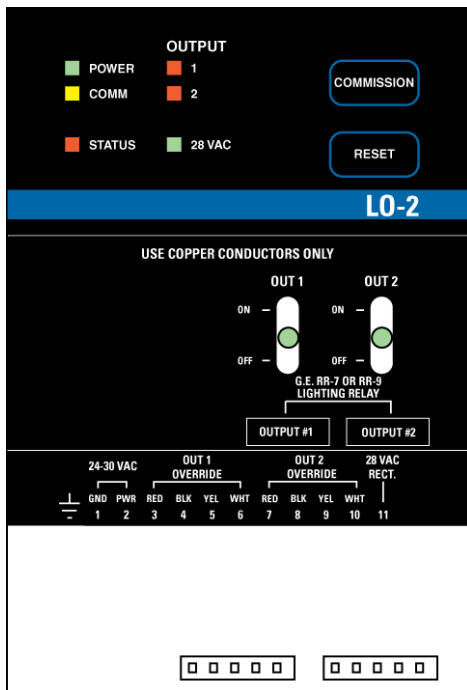

### FEATURES

- 2 Lighting Outputs
- Uses standard RR-7 or RR-9 relays
- External 28 VAC required to power GE relays
- On-board logic powered by Andover Continuum Power Supply or External 28V transformer. Therefore, when the LO-2 is remotely located, it can be powered by 28 VAC alone.
- Output Status LEDs

#### **LO-2-O Only:**

- Override Toggle Switches

## SPECIFICATIONS

### ELECTRICAL

<b>Power Supply Range:</b>	Input Voltage Range: 20-26V.
<b>Power Consumption:</b>	0.4 Watts (16 mA) @ 24 VDC (max.); provided by Andover Continuum power supply module. Consumes no DC power when external AC power is present.
<b>External AC Power:</b>	28 VAC powers both the module and lighting relays; can also power the LO-2 module when mounted remotely.
<b>External Transformer Size:</b>	40 VA transformer provides power for up to 5 LO-2 modules (10 GE relays and associated devices).
<b>Overload Protection:</b>	DC: 0.5 A resettable fuse with transient voltage suppressor (TVS) and reverse polarity protection. AC: 0.5 A resettable fuse with MOV.

### INPUTS/OUTPUTS

<b>Inputs:</b>	2 Class II Low Voltage override inputs, providing direct control of lighting relays
<b>Input Protection:</b>	Transient voltage suppressors (TVS) with reverse polarity protection
<b>Outputs:</b>	
<b>Output Type:</b>	2 pulsed lighting control outputs compatible with externally mounted GE RR7 or RR9 relays
<b>Output Rating: (Relay)</b>	Lamp Load – 20 Amp Tungsten Filament @ 125 VAC Resistive Load – 20 Amp Ballast @ 277 VAC (20 amp @ 347 VAC, Canada) Motor Load – 0.5 Hp @ 110–125 VAC 0.5 HP @ 220–277 VAC (0.5 Hp @ 347 VAC, Canada) <i>Pilot Contact Rating (RR9 only): 1 Amp, 24 VAC, isolated</i>
<b>Output Feedback:</b>	RR9 relays have LED status indication and software feedback for relay status
<b>Output Protection:</b>	Transient voltage suppressors (TVS) on outputs. GE relays provide isolation.
<b>Overrides:</b>	Momentary override toggle switches (LO-2-O model only)
<b>Power/Output Connections:</b>	Two-piece, 12-position removable terminal block
<b>Lighting Relay Connections:</b>	5-position male connector accepts standard GE female plug-in connector.

## I/O Connections

The actual I/O connections are located on a combination of a twelve-position removable screw terminal connector located at the center of the module and two five-pin Molex relay connectors at the bottom.

The diagram below indicates where each output number is located in the terminal block.

Connection	Description
	Earth Ground
1.	GND for 24–30V Ext. Power
2.	24–30V External VAC
3.	OUT 1 RED
4.	OUT 1 BLK
5.	OUT 1 YEL
6.	OUT 1 WHT
7.	OUT 2 RED
8.	OUT 2 BLK
9.	OUT 2 YEL
10.	OUT 2 WHT
11.	24 VAC RECT

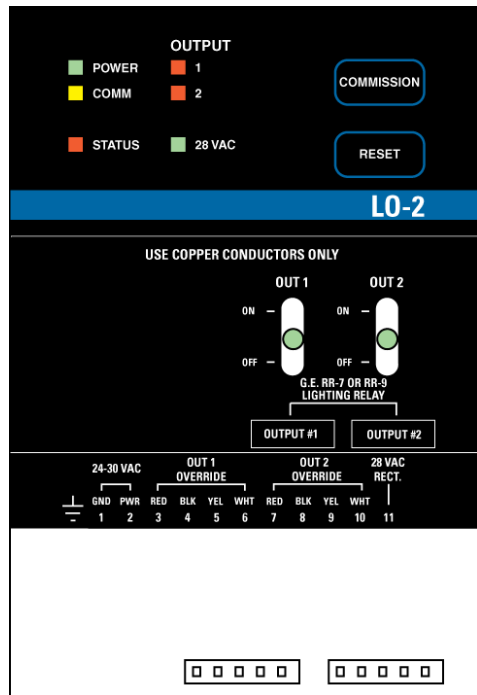

## Electrical Description

The outputs of the LO-2 module are digital in nature (ON or OFF) yet are designed specifically to control lighting. The two outputs are electrically connected (via cable) to an external bracket where two GE-style lighting relays (RR-7 or RR-9) have been mounted.

Both outputs can be controlled via program or be activated manually through override switches (LO-2-O only) on the front panel. An external momentary switch (a push button, motion detector or other occupancy sensor) can be wired to control each of the relays as well.

The GE relays mechanically latch in the ON position when energized. The relay remains ON until set to OFF from the program or any external override controls. RR-9 relays also provide operational status information (ON or OFF) that can be read via Plain English commands. The OUTPUT indicators on the front panel illuminate if the RR-9 relay output is ON.

### Override Controls

The LO-2-O model includes a built-in output override switch for each output.



The operation of the relays can be operated from program control or manual control using the front panel mounted override switches or externally wired controls.

The following describes the actions associated with each position of the override controls:

- ON**      The output relay is energized to an “ON” state manually by setting the switch to ON. The spring-loaded momentary action of the switch moves the switch back to the center position after pressing.
  
- OFF**      The output relay is de-energized to an “OFF” state manually by setting the switch to OFF. The spring-loaded momentary action of the switch moves the switch back to the center position after pressing.

### **External Override Capabilities**

Two Class II low voltage manual override inputs, one for each relay output, are provided for override capabilities. These inputs directly control the lighting relays, independent of any schedule or program. Wall switches, occupancy sensors, or a combination of both may be wired to these inputs.

### **Lighting Control**

The LO-2 can be coupled with Andover Continuum's programmable input modules to provide flexible lighting control strategies such as:

- Outdoor Lighting Control with a Photocell
- Daylight Control
- After-Hours Lighting Usage with Card Swipe Readers
- Adjustable Override Time with Flick Warning
- Cleaning Crew Override
- Data Logging and Reporting
- Run time Analysis, including Accumulated On-Time and Percentage On-Time
- Tenant Billing Reports
- Custom Control Strategies

These programs can be easily modified to fit the exact needs of your project.

## Electrical Installation

### External Power

The GE relays are powered by an external 28 VAC source. The LO-2 module has been designed to utilize this external power source as its own module supply source as well. It is not necessary to power the module in this way. However, if the LO-2 is located remotely from your main power source, you may want to power the module locally thereby eliminating the two extra wires necessary to bring power to the module from the Andover Continuum power supply. It also lessens the load requirements on that supply.

### 28 VAC Relay Power

Connect the output of a 28 VAC transformer to the module power inputs as shown:

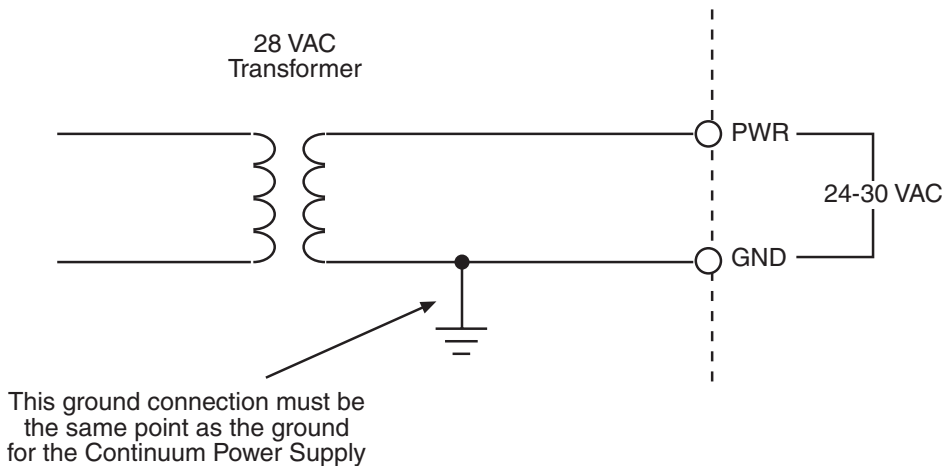

### External Control Power

Externally mounted sensors such as proximity sensors require power to operate as well. The LO-2 module provides a connection for these devices to receive half wave rectified 28 V power as indicated below:

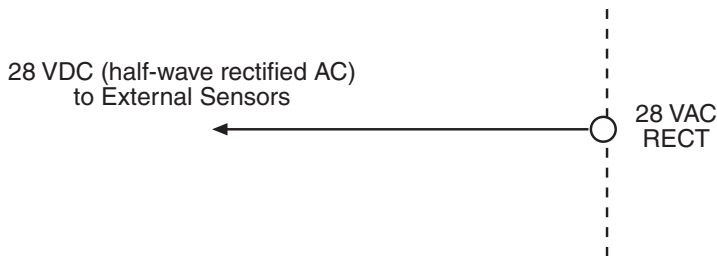



## Relays

The GE relays are mounted externally and are connected to the LO-2 via a connecting cable. This cable terminates in a five-pin Molex-style connector that mates easily with one of the two headers provided at the bottom of the module as shown below:

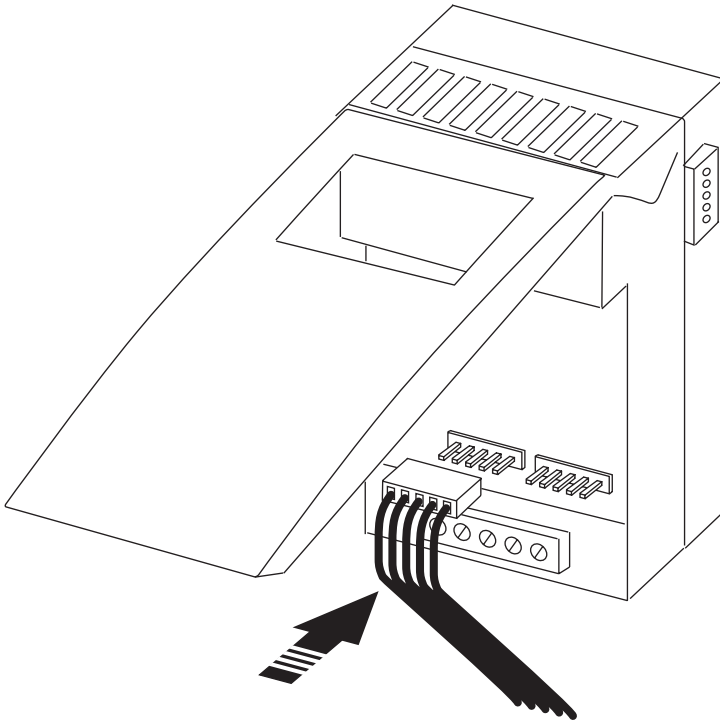

The connector is keyed so that it locks into place after insertion. The connector on the left is output relay #1 and the one on the right is output relay #2. External relays are attached to the provided cable by matching the colors to those attached to the relay.

The following indicates the connections for each pin of the relay connector:

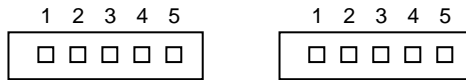

- 1 Blue      24VAC Rectified
- 2 Red      On
- 3 Black     Off
- 4 Yellow \* Pilot Contact Return
- 5 Yellow \* Pilot Contact Source

\* These connections only apply to the RR9 relay.

## Wiring External Controls

The relays can each be controlled by external momentary switches or other momentary device such as a proximity detector. Each relay contains a set of input connections for the control. Connect the external control(s) as shown:

### Mechanical Switch without Integral Indicator:

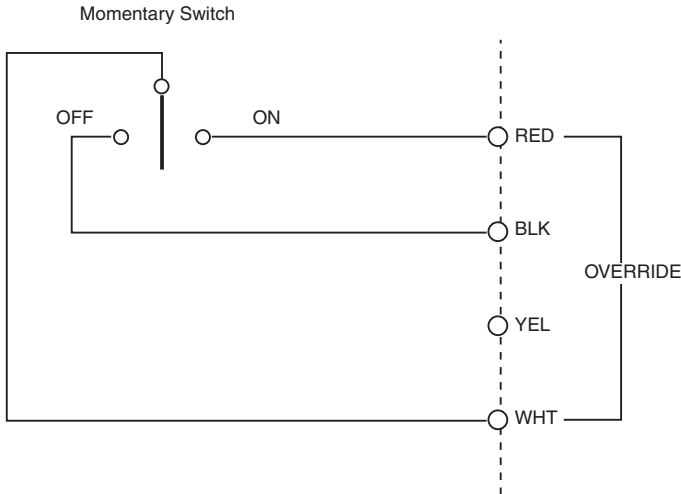

### Mechanical Switch with Integral Indicator:

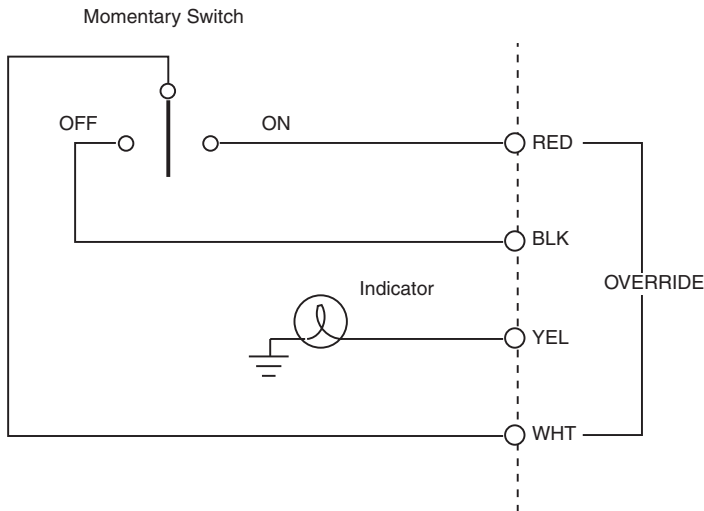

### Controlling both Outputs with One Switch

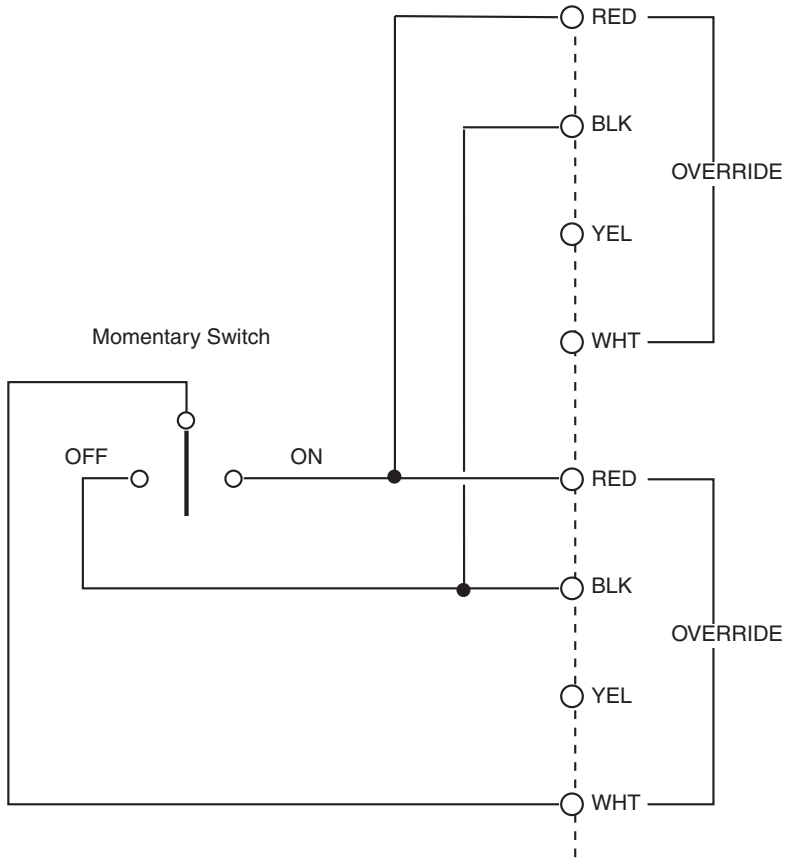

Occupancy Sensor Connection

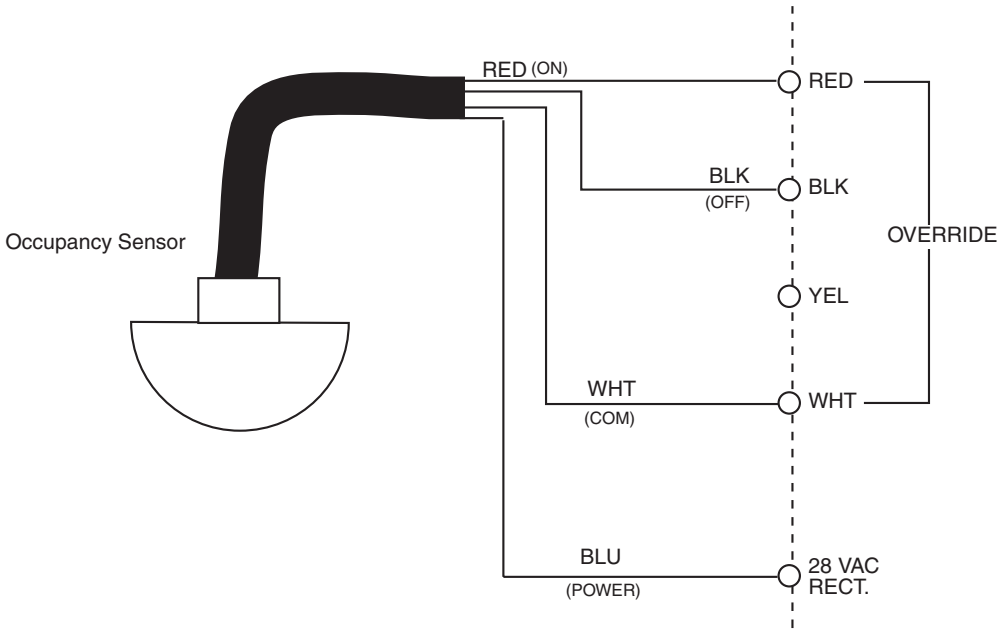

**Controlling both Outputs with One Occupancy Sensor**

To control both relays with the same Occupancy sensor, simply wire the red and black connections of each input bank together as indicated on the drawing on the previous page.

## Status/Control Panel

### Status Indicators

The LO-2 module includes a complete indicator status panel on the front of the module.

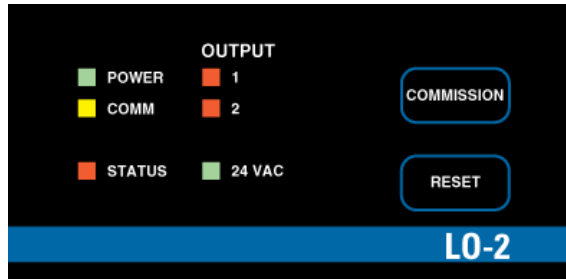

This panel includes indicators reporting on the status of the following:

- |               |   |
|---------------|---|
| <b>POWER</b>  | This green indicator illuminates when DC power is applied through the I/O Bus.  |
| <b>COMM</b>   | This yellow indicator illuminates when data is transmitted from the module to the NetController. In normal operation, data is only transmitted when an input value changes.<br><br>This indicator will also flash periodically as the NetController checks the I/O bus.             |
| <b>STATUS</b> | This red indicator is normally off. If it is always on or flashing at a fast rate, there is a problem with the module.<br><br>This indicator can be manually illuminated from CyberStation or Command Terminal and used as a troubleshooting aid when locating a particular module. |
| <b>OUTPUT</b> | These red indicators (one for each channel) illuminate when an 'ON' condition is set. These indicators operate with RR-9 relays only.   |
| <b>28 VAC</b> | This green indicator illuminates when 24–30 VAC power is supplied to the module by an external source.  |

This panel also includes two operator switches that perform the following:

- COMMISSION** After physical installation and during configuration through the CyberStation workstation or Command Terminal, pressing this button registers the module's address with the system. For more information, refer to the section on *Module Configuration* found earlier in this manual.
- RESET** If the module becomes inoperable, pressing this button resets the module. It does not erase its memory.

## DIO-20 Input/Output Expansion Module

The DIO 20 provides a connection for up to 20 solid state input or output modules for the Andover Continuum DM-20 Digital I/O module. The DIO 20 module can be mounted via a DIN Rail or directly to a panel. The DIO 20 includes individually fused sockets for up to 20 solid state input/output modules from manufacturers such as Opto 22, Grayhill, Gordos, Crydom and Potter & Brumfield.

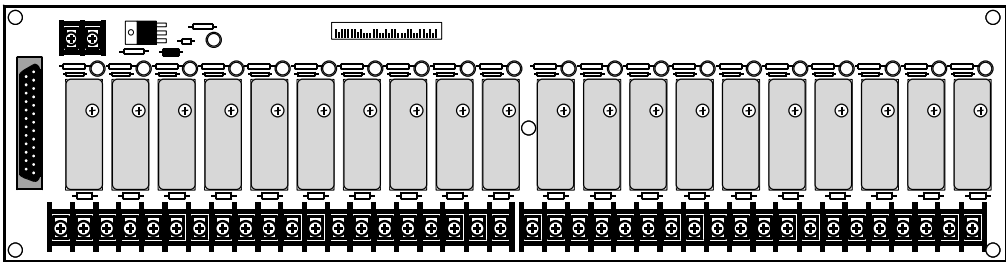

### FEATURES

- 20\* General Purpose Digital Inputs/Outputs
- Each point may be configured as an input or an output
- Direct connection to DM-20 Expansion Module
- *\*The actual number of modules that a DM-20 can power depends on the mix of input and outputs modules desired. Refer to the DM-20/DIO-20 Power Requirements section found on page 94.*

## SPECIFICATIONS

### ELECTRICAL

<b>Power Supply Range:</b>	24 VDC
<b>Power Consumption:</b>	All input modules installed: 12.7 Watts (529 mA) max; provided by an external power supply module.  All output modules installed: 8.5 Watts (354 mA) max; provided by an external power supply module.  DIO-20 board alone: 20mA Input Module max current: 23mA Output Module max current: 16mA
<b>External Power Connector:</b>	Two-position terminal block
<b>Overload Protection:</b>	5A fuse on all input/outputs.

**INPUTS/OUTPUTS** 20 total points; user-selectable channel-by-channel as inputs or outputs

**Inputs:**  
**Input Type:** Input ratings depend on input module(s) selected.

**Outputs:**  
**Output Type:** Output ratings depend on input module(s) selected.

**I/O Connections:** 25-position DB25 Female to DM-20  
40-position screw-type terminal block for I/O

**Compatible\* Modules:**

**Opto-22 Inputs** IDC24; 10-30VDC  
IAC24; 90-140VAC or VDC  
IAC24A; 180-240VAC

**Opto-22 Outputs** ODC5; 60VDC@3A  
ODC5A; 200VDC@1A  
OAC5; 120VAC@3A  
OAC5A; 240VAC@3A  
OAC5A5; 120/240VAC@3A

*\* These manufacturers and model numbers represent devices that should be compatible. Their physical and electrical specifications appear to meet those of our product. However, this list does not constitute an endorsement of the product nor does it imply that the specifications listed are accurate. Ratings listed are nominal. Refer to manufacturer's data sheets for limitations.*



## DIO-20 Installation

The DIO-20 (which includes the DIO 20 printed circuit board, three plastic PCB mounting brackets, and three plastic DIN rail mounting brackets) can be mounted to either a DIN Rail or directly to a bulkhead. The following are additional items required for installing the DIO-20:

- Andover Continuum DM-20 I/O module
- 24 VDC Power Source
- Input/Output Wires
- 25-pin Interface cable
- Input/Output Modules
- Two DIN End Clamps
- DIN Rail
- Enclosure

### Mounting to a DIN Rail

1. Slide an end clamp into position on the DIN Rail. Tighten the holding screws.

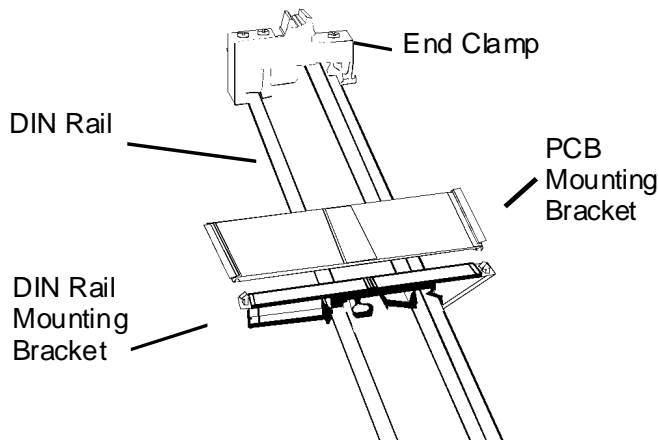

2. Slide a DIN Rail Mounting Bracket under the PCB mounting bracket until flush on the back side.

3. Slide the DIN rail mounting bracket/PCB bracket assembly onto the DIN rail until flush with the end clamp.
4. Insert one end of the module PCB into the PCB bracket. Slide the board into the middle channel of the mounting bracket. Slide the DIN rail/PCB mounting bracket assembly onto the board and DIN rail. Carefully slide the assembled brackets into the center of the module board.
5. Slide the remaining bracket onto the DIN rail and position it at the end of the board.
6. Mount another end clamp. Tighten the screws on the end clamp.

### Mounting Directly to a Panel

There are four #6-sized holes (0.156" (4mm)) provided at the corners and one in the center for mounting using stand-offs directly to a flat surface. The following illustrates the mounting dimensions of the module.

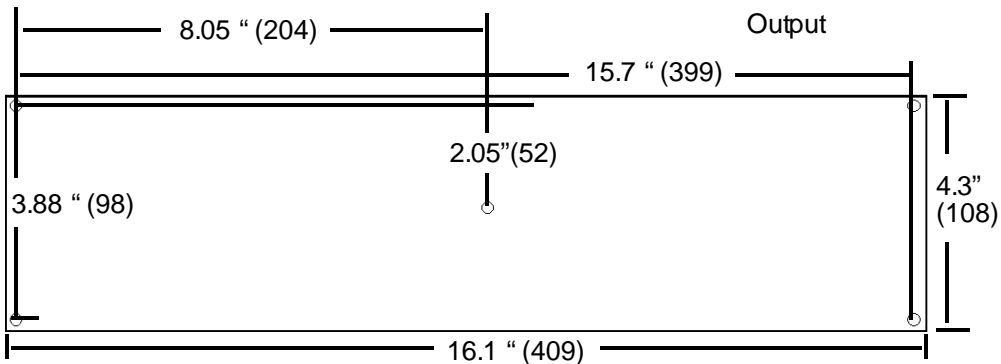

## I/O Connections

The connections to the DM-20 are located on a 25-position DB25-type female connector located at the left side of the module. A separate two-conductor screw-type terminal connector provides 24VDC power.

The input/output connections are located on a 40-position terminal block connector along the bottom of the module. These connections are labeled I/O1, I/O2, I/O3, and so forth. Each input/output occupies two adjacent positions of the connector.

The diagram below indicates where each input number is located on the module.

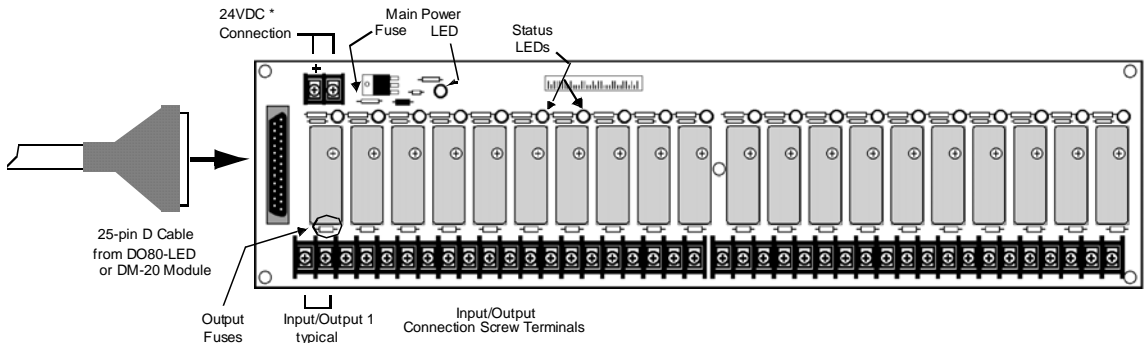

**25-Pin D Connector**

Connection	Description	Connection	Description
1	I/O 1	13	I/O 13
2	I/O 2	14	I/O 14
3	I/O 3	15	I/O 15
4	I/O 4	16	I/O 16
5	I/O 5	17	I/O 17
6	I/O 6	18	I/O 18
7	I/O 7	19	I/O 19
8	I/O 8	20	I/O 20
9	I/O 9	21	Ground
10	I/O 10	22	Ground
11	I/O 11	23	Ground
12	I/O 12	24	Ground
		25	Ground

**40-Position Terminal Block**

<b>Connection</b>	<b>Description</b>		<b>Connection</b>	<b>Description</b>	
1	I/O 1	□	21	I/O 11	□
2	I/O 1	□	22	I/O 11	□
3	I/O 2	□	23	I/O 12	□
4	I/O 2	□	24	I/O 12	□
5	I/O 3	□	25	I/O 13	□
6	I/O 3	□	26	I/O 13	□
7	I/O 4	□	27	I/O 14	□
8	I/O 4	□	28	I/O 14	□
9	I/O 5	□	29	I/O 15	□
10	I/O 5	□	30	I/O 15	□
11	I/O 6	□	31	I/O 16	□
12	I/O 6	□	32	I/O 16	□
13	I/O 7	□	33	I/O 17	□
14	I/O 7	□	34	I/O 17	□
15	I/O 8	□	35	I/O 18	□
16	I/O 8	□	36	I/O 18	□
17	I/O 9	□	37	I/O 19	□
18	I/O 9	□	38	I/O 19	□
19	I/O 10	□	39	I/O 20	□
20	I/O 10	□	40	I/O 20	□

## AC-1 Access Control Module

The AC-1, Access Control Module, provides full I/O for an access controlled door or portal in one compact module. The AC-1 can be remotely located at a door reader for localized control and reduced wiring costs; or several AC-1 modules can be grouped together and DIN rail-mounted for centralized control.

The AC-1 provides a Wiegand card input for Wiegand and Proximity type cards, reading up to 64 bits per card. Reader power is switch-selectable between 5 volts and 12 Volts to meet most card reader power requirements.

The AC-1 provides two 5 Amp, Form C relays—one for the door lock and a second for local alarm annunciation. Each output has an integral hand-off-auto switch for manual operation, and software feedback of the switch position.

Up to three supervised alarm inputs can be used for door status contacts, request-to-exit devices, a cabinet tamper switch, and any other two-state or three-state (on/off/trouble) alarm device.

### Keypad Control

The AC-1 supports Wiegand output keypads. To simplify installation and reduce wiring costs, the keypad data comes into the module via the reader data lines.

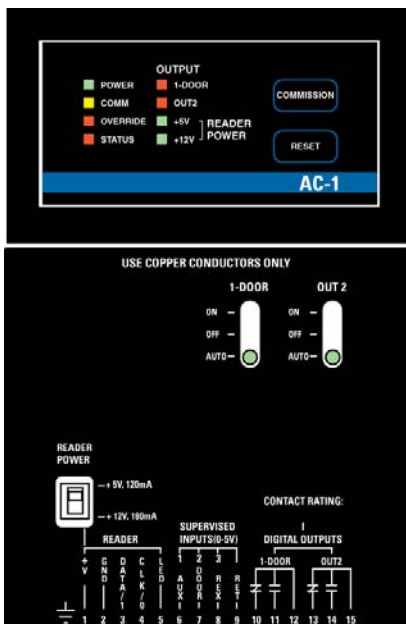

### FEATURES

- 1 Card Reader Input
- +5 V or +12 V reader power (switch selectable)
- 1 Card Reader LED control output
- Up to 3 Supervised Inputs
- 2 FormC Relay Outputs rated 24 VAC/DC @ 5A
- Override Toggle Switches w/Override Detection and Feedback

## SPECIFICATIONS

### ELECTRICAL

<b>Power Supply Range:</b>	Input Voltage Range: 20-26V. 24V UL294 installations.
<b>Power Consumption:</b>	2.6 Watts + (15 Volts) * (Reader Current) max. @ 24 VDC; normally provided by Andover Continuum power supply module.
<b>Overload Protection:</b>	0.5 A resettable fuse with transient voltage suppressor (TVS) and reverse polarity protection

### INPUTS/OUTPUTS

#### Inputs

<b>Card Readers:</b>	1									
<b>Card Reader Type:</b>	Wiegand and Proximity readers *									
<b>Maximum Number of bits/Card:</b>	64									
<b>Card Reader Power:</b>	+5 V or +12 V (switch selectable)									
	<table> <thead> <tr> <th>Switch Setting</th> <th>Output Voltage</th> <th>Output Current</th> </tr> </thead> <tbody> <tr> <td>+5 V</td> <td>+5.20 V <math>\pm</math>0.05V</td> <td>120 mA (max.)</td> </tr> <tr> <td>+12 V</td> <td>+12.0 V <math>\pm</math>5%</td> <td>180 mA (max.)</td> </tr> </tbody> </table>	Switch Setting	Output Voltage	Output Current	+5 V	+5.20 V $\pm$ 0.05V	120 mA (max.)	+12 V	+12.0 V $\pm$ 5%	180 mA (max.)
Switch Setting	Output Voltage	Output Current								
+5 V	+5.20 V $\pm$ 0.05V	120 mA (max.)								
+12 V	+12.0 V $\pm$ 5%	180 mA (max.)								
<b>Wiring Distance:</b>										
<b>Card Reader to AC-1:</b>	500 ft. max. using 18-gauge wire 200 ft. max. using 22-gauge wire									
<b>Alarm Inputs:</b>	Up to 3 supervised inputs. Single or double resistor supervision, series or parallel.									
<b>Input Protection:</b>	Transient Voltage Suppressor (TVS) on each input									

#### Outputs

<b>Door Outputs:</b>	2 Form C relays
<b>Output Rating:</b>	24 VAC/VDC @ 5 Amp
<b>Reader LED Output:</b>	Open collector; up to 50 mA.
<b>Output Protection:</b>	5000 V isolation 270 V MOVs on each output
<b>Overrides:</b>	3-position manual override switch on each output for manual control of relay. LED override status indicator.
<b>Override Feedback:</b>	Override detection and software feedback provided for each output.

\* The following reader and keypad models are the only approved for use in UL 294 Access Control applications:

Essex KTP-163-SN keypad; HID Epic 32985 reader; Indala ASR-500 reader.

## I/O Connections

The actual I/O connections are located on a sixteen-position removable screw terminal connector located at the bottom of the module. Wires should enter from either the top or bottom wiring troughs, and outputs should come from the right side of the rack, inputs from the left (by convention).

The diagram below indicates where each output number is located in the terminal block.

Connection	Description
	Earth Ground
1.	Reader +V
2.	Reader GND
3.	Reader DATA (Wiegand I)
4.	Reader CLK (Wiegand 0)
5.	Reader LED
6.	Sup Input Aux
7.	Sup Input Door
8.	Sup Input REX
9.	Sup Input RETURN
10.	Door NC
11.	Door NO
12.	Door COM
13.	OUT2 NC
14.	OUT2 NO
15.	OUT2 COM

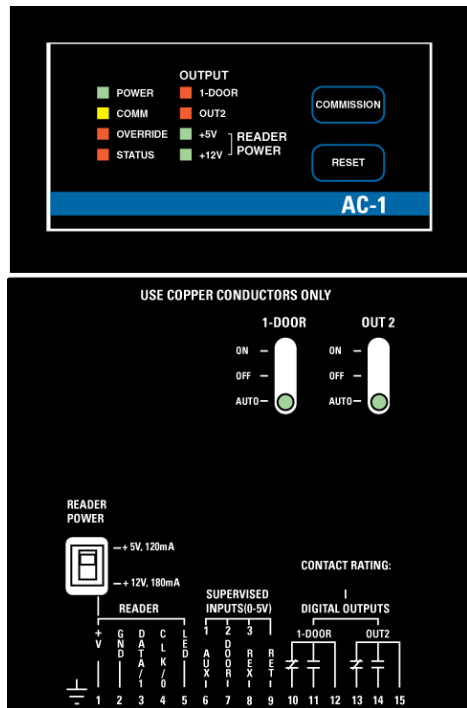

## Using the AC-1

AC-1 is a complete card access control module designed to interface with the Schneider Electric NetController where an internal firmware-based Access Control supervisor resides. During normal operation, access control decisions are made in the Andover Continuum NetController CPU module database, which provides storage for up to 75,000 “local” personnel records (up to 4 million records may be created per database).

The AC-1 is designed to control a single door. The door can be configured to allow entrance based on card only, card plus personal ID number (PIN), or keypad only. The door’s operating mode can even be changed based on time-of-day or other events for optimum flexibility through Schneider Electric’s easy-to-use *Plain English* programming language. Each keypad can also permit entry of a duress alarm code that can initiate an alarm sequence at any AC-1 controller or at the CyberStation workstation.

Time-based anti-passback and entry/egress anti-passback are available to prevent tailgating. Entry/egress anti-passback is system-wide and can be performed by readers located on different AC-1 controllers across the network.

Using *Plain English*, the AC-1 can also be used for custom access control sequences such as two-man rule, optical turnstile control, and man trap configurations.

### Reader Power Switch

Readers are available in both 5 Volt and 12 Volt varieties. The AC-1 module supports both by allowing the selection of a reader power source. A voltage selector switch is located on the front panel of the module. Insert the tip of a small screwdriver to slide the internal power switch into the desired position.

**Caution: Make sure the Reader Power switch is set properly. Setting the switch to 12 V for a 5 V reader may damage the unit.**

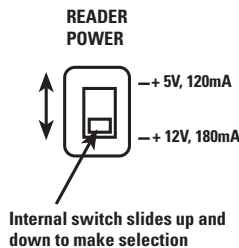



## Degrade Mode

If network communications are interrupted, as a fail-safe mode, the AC-1 will revert to a programmable degraded mode of operation. System operation during degrade mode provides uninterrupted card access using site codes, cards formats, and other degrade mode parameters stored in non-volatile EEPROM in each AC-1 module.

Degrade mode parameters are configured from the “Access Validation” section of the door editor’s “Entry Reader” tab. For dual reader doors, configurable degrade mode parameters are available from the “Access Validation” section of the door editor’s “Exit Reader” tab.

During degrade mode, the AC-1 module supports:

- Two of the site codes entered on the “Card Formats” tab of the door editor (out of four supported by the door during normal operation). The site codes supported are Site1 and Site2.
- One card type (determined below)

In NetController version 1.4 and forward, when more than one card type is selected at the door, the following procedure determines which one of the card types the AC-1 stores for degrade mode operation:

1. Open the door editor and de-select all card types except the one that you want the AC-1 to store for degrade mode operation.
2. Save the door settings by clicking “Apply”.
3. Select the other card types that will be allowed at the door in normal operation.
4. Save the door settings again by clicking “Apply” or “OK” to save and close the door editor.

---

**WARNING:** The AC-1 is not recommended for use with inverted door output installations. For inverted door output installations, use the AC-1A or AC-1 Plus modules.

---

## Connecting a Reader/Keypad

### Reader/Keypad Inputs

The AC-1 includes a full interface to a single Wiegand access card reader. The modules were designed to allow integral reader/keypad units to be connected directly. Separate keypads that have similar interfaces (Wiegand) can be connected in parallel with a reader through the use of the Keypad Interface Module as shown on the following page.

The Wiegand reader and/or reader/keypad unit is connected to the AC-1 module as shown below:

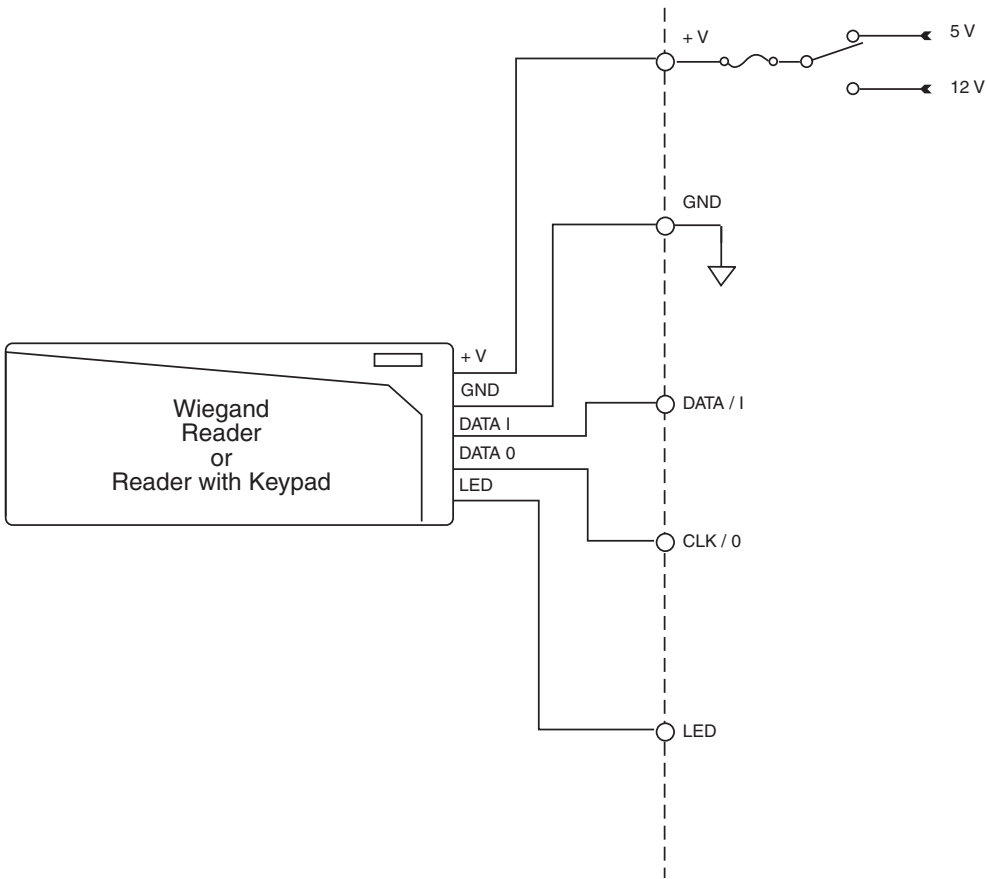

**Connecting Two Readers or a Keypad and a Reader**

With the addition of the Keypad Interface Module (KIM), the AC-1 can interface to both a keypad and a reader simultaneously. This assumes that they are both Wiegand devices of similar voltage range. The KIM module presents the AC-1 with one pair of signals.

Similarly, two readers can be connected with the KIM. This allows a site to slowly introduce a different type of reader (i.e., proximity) while allowing access through the normal reader. The KIM connects as shown below:

**Note: The KIM is not approved for use with UL 294 Access Control Systems.**

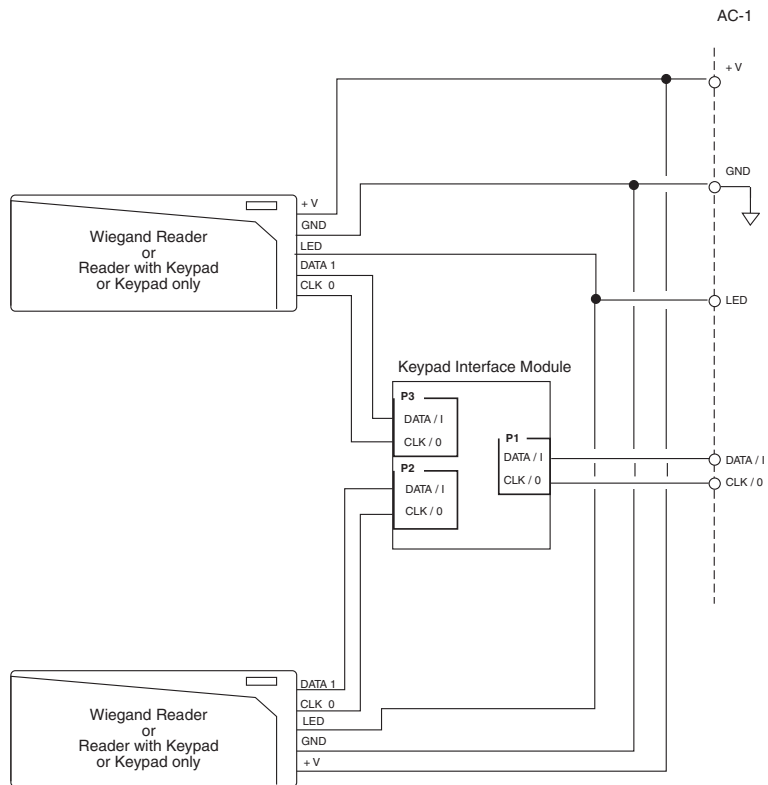

## Connecting a CardKey Reader via the EMX34

With the addition of the Schneider Electric EMX34 CardKey to Wiegand interface you can connect a CardKey reader to the AC-1.

The reader connects as shown below:

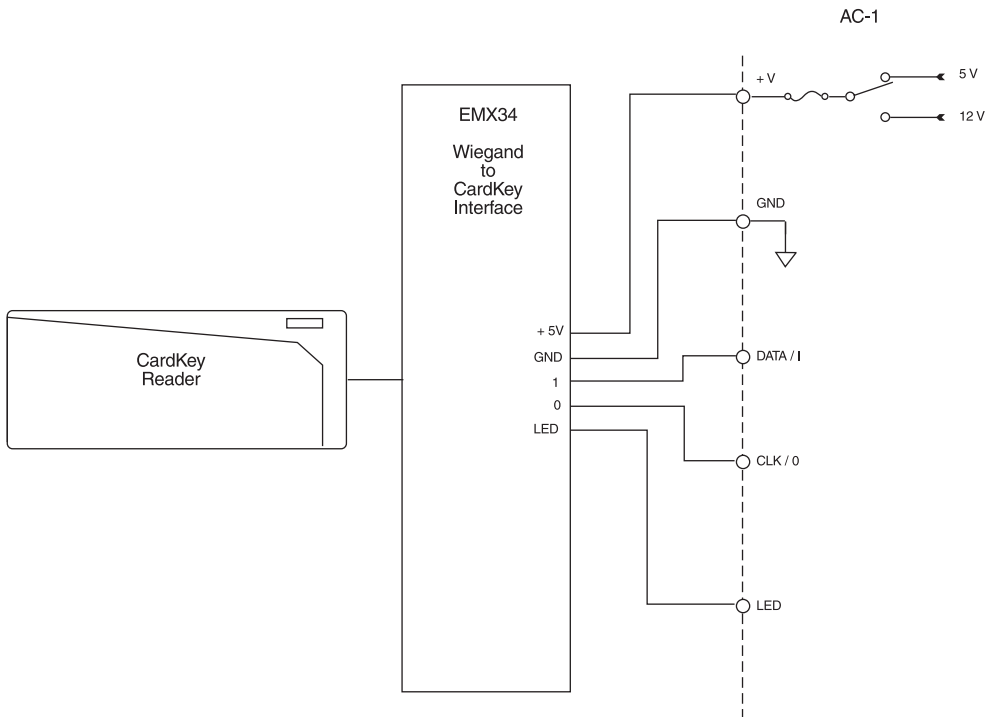

### Connecting a Dual Reader Door

With the addition of another AC-1 module, a door can be configured as a dual reader door. A door is a dual reader door when it has been configured with an entry and exit IOU module.

A dual reader door is connected as shown below:

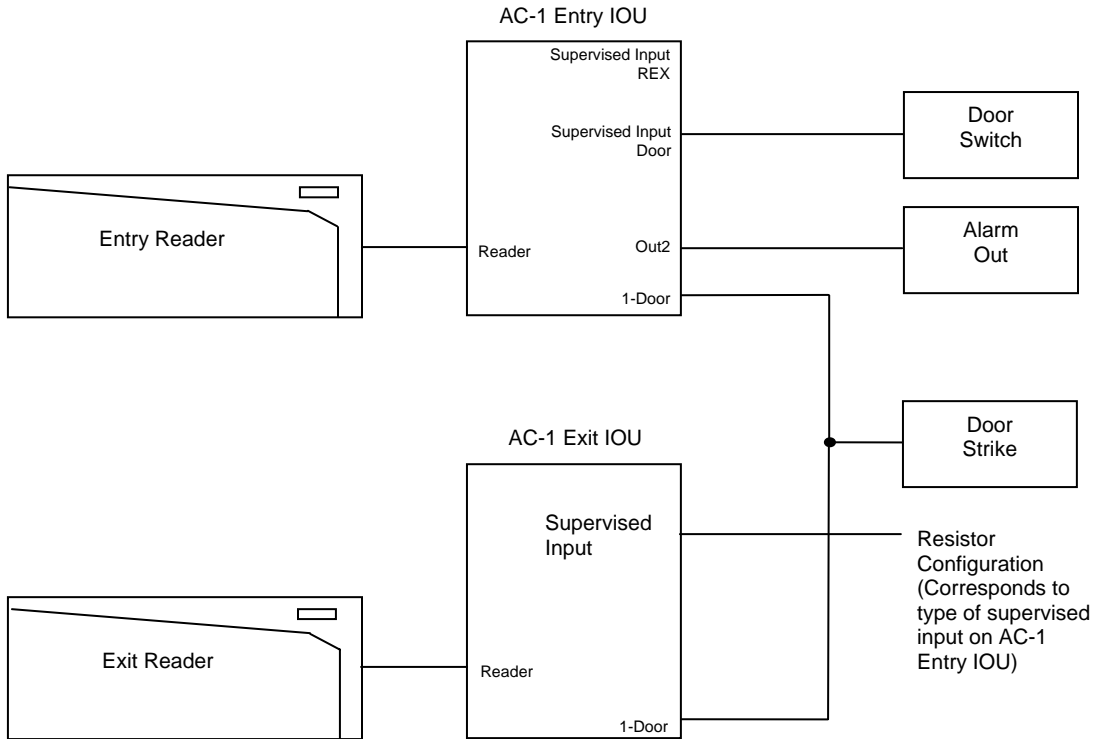

**NOTE:** As the door switch connects only to the Entry IOU, the door switch operation at the Exit IOU is not supported in degrade mode.

**NOTE:** The resistor configuration on the AC-1 Exit IOU matches the resistor configuration of the supervised input type. (Examples: NC Series, NC Series Parallel, or NO Series Parallel.) Connect **only** the resistor across the input, not any other wire connections.

## Connecting Supervisory Inputs

All AC-1 inputs are supervisory inputs. The following drawings depict the three types of supervisory inputs that exist—two normally closed and one normally open type.

**NOTE:** All resistor values are to be  $10\text{K} \pm 5\%$ .

### Normally Closed Supervised Inputs

#### NC Series

With this type of input wiring, a resistor is placed in series with the input being monitored. When the input contact presents a short circuit (normal closed position) the input is assumed in a normal closed state, the circuit presents a reading of  $10\text{K}\ \Omega$ s at the input.

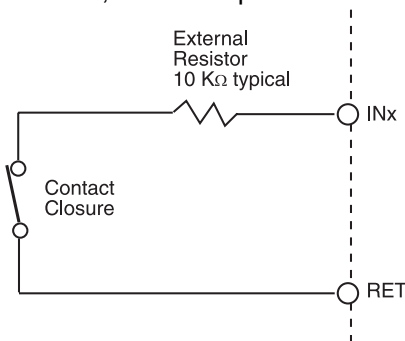

#### Circuit Action

Switch Closed  
Switch Opened  
Wire Cut  
Input Shorted

#### Input Senses

External Resistance  
Infinite Resistance  
Infinite Resistance  
Zero  $\Omega$ s

#### Condition

Input contact Closed  
Input contact Open  
Input contact Open 'Violation'  
Violation or error

When the input contact is opened, the circuit opens and an infinite resistance is measured. If the wires to the input contact are cut it also appears as an "Input Contact Open" condition. In this case there would be an input contact open without a valid card swipe or valid keypad entry resulting in an "Input Contact Violation". Shorting the input causes a zero  $\Omega$  resistance, which also results in an input contact violation.

When configuring for this type of contact select:

**ElecType:**        **Supervised**  
**Resistor Type:**   **NCSeries**

## Normally Closed Supervised Inputs

### ***NC Series Parallel***

With this type of input wiring, two external resistors are added to the input, one in series and the other in parallel. When the input contact switch is closed (normal position) the input contact is assumed to be closed. The circuit presents a reading composed of both resistances in parallel that works out to be half the value of one of them (5 K $\Omega$ ).

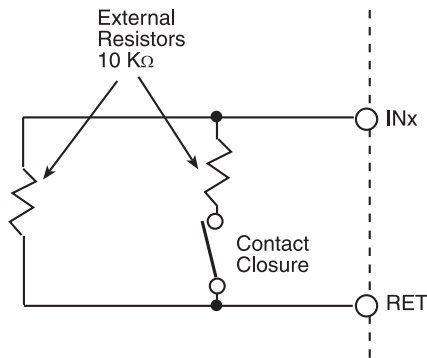

<b>Circuit Action</b>	<b>Input Senses</b>	<b>Condition</b>
Switch Closed	External Resistance $\div 2$	Input contact Closed
Switch Opened	External Resistance	Input contact Open
Wire Cut	Infinite Resistance	Violation or error
Input Shorted	Zero $\Omega$ s	Violation or error

When the input contact is opened the switch opens and the value of the parallel resistor is measured. If the wires to the input contact are cut it appears as an infinite resistance. Shorting the input causes a zero  $\Omega$  resistance. Both a short and an infinite resistance (open) should result in an error condition.

When configuring for this type of contact select:

**ElecType:**        **Supervised**  
**Resistor Type:** **NCSerPar**

## Normally Open Supervised Inputs

### **NO Series Parallel**

With this type of input wiring, two external resistors are added to the input, one in series and the other in parallel. When the input contact switch is open (normal position), the input contact is assumed to be closed. The circuit reads the value of the parallel resistor.

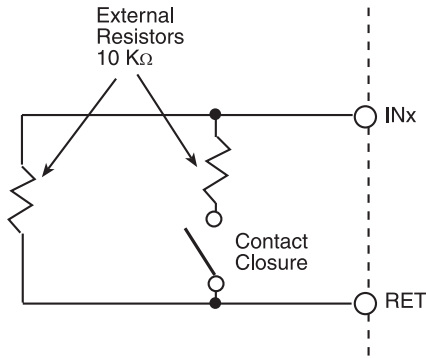

Circuit Action	Input Senses	Condition
Switch Closed	External Resistance ÷ 2	Input contact Open
Switch Opened	External Resistance	Input contact Closed
Wire Cut	Infinite Resistance	Violation or error
Input Shorted	Zero Ωs	Violation or error

When the input contact is opened, the switch closes and a reading results that is composed of both resistances in parallel that works out to be half the value of one of them (5 KΩ). If the wires to the input contact are cut it appears as an infinite resistance. Shorting the input causes a zero Ω resistance. Both a short and an infinite resistance (open) should result in an error condition.

When configuring for this type of contact select:

**ElecType:**        **Supervised**  
**Resistor Type:** **NOSeriPar**



**Wiring Door Switches**

There are three supervisory inputs for door switches. The maximum length wire you can use is 500 ft of #18 gauge wire (152 m of 1.0 mm<sup>2</sup> wire) or 200 ft of #22 gauge wire (60 m of 0.35 mm<sup>2</sup> wire).

Some switches have built-in resistors that facilitate Series Parallel connections as shown below:

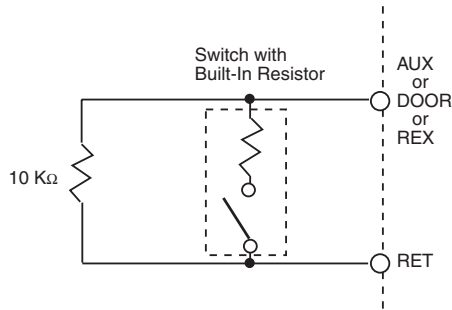

**Wiring Motion Detectors**

Motion detectors are devices that close a switch contact when motion is detected.

Wiring is similar to a normal door switch input; however, the motion sensor requires an external power supply of 12 VDC or 24 VDC (UL listed under APHV). The maximum length wire you may use is 500 ft of #18 gauge wire (152 m of 1.0 mm<sup>2</sup> wire) or 200 ft of #22 gauge wire (60 m of 0.35 mm<sup>2</sup> wire).

The following shows a typical motion detector circuit:

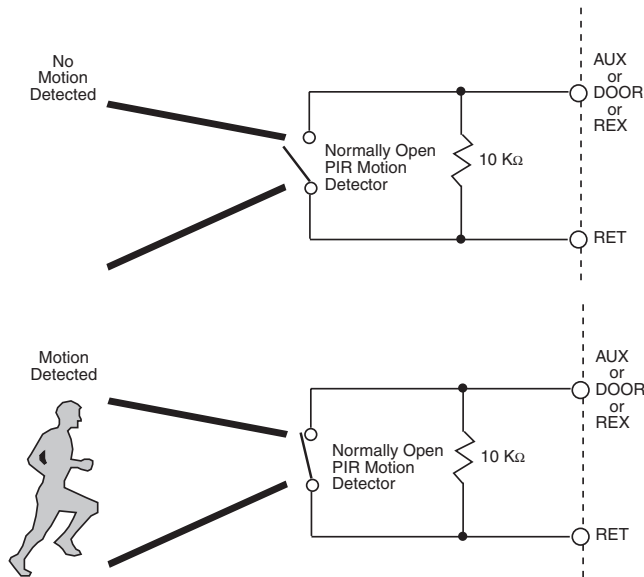

## Connecting Outputs

The AC-1 module includes two Form C single-pole double-throw relay outputs. The following is a simplified schematic of each output channel:

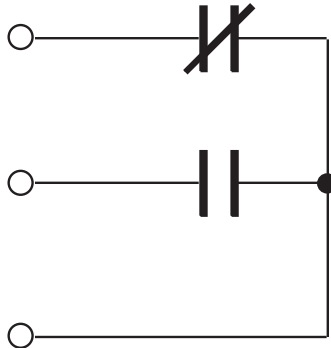

Both channels resemble the circuit shown above.

To use the Form C output in your system, configure an output point with an Electrical Type of ***Digital***.

These output contacts operate as a standard relay. When the output is set to an “ON” state, the normally open contacts close and the normally closed contacts open.

**Note:** When configuring a Digital point, there is a “Polarity” attribute. If this attribute is enabled, the operation of the outputs are reversed.

## Override Controls

The AC-1 module includes an output override switch for each output.

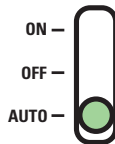

The output of the module can be directed from program control or manual control. The output can be disabled completely as well.

The following describes the actions associated with each position of the override controls:

- ON**                    The output relay is energized to an “ON” state manually by setting the switch to ON. Programs have no effect on the output when the switch is in this position.
  
- OFF**                    The output relay is de-energized to an “OFF” state manually by setting the switch to OFF. Programs have no effect on the output when the switch is in this position.
  
- AUTO**                    The action of the output relay is determined as a direct result of program control.

## Wiring Door Outputs

The following represents a typical door output installation when the circuit is normally open:

### One-reader Door Configuration

AC-1

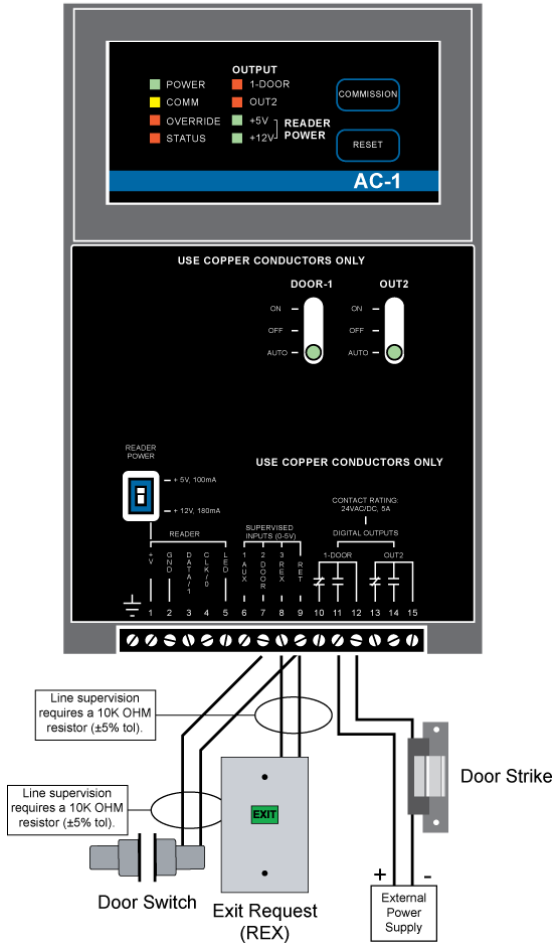

This configuration shows a normally de-energized lock (when secured) in a fail secure mode. If power loss occurs, the lock closes. Always be sure to use “panic” hardware that allows emergency exit from the secured area.

## Wiring Dual Reader Door Outputs

The following represents a typical door output installation when the dual reader door circuit is controlling a fail-secure lock:

### Dual-reader Door Configuration

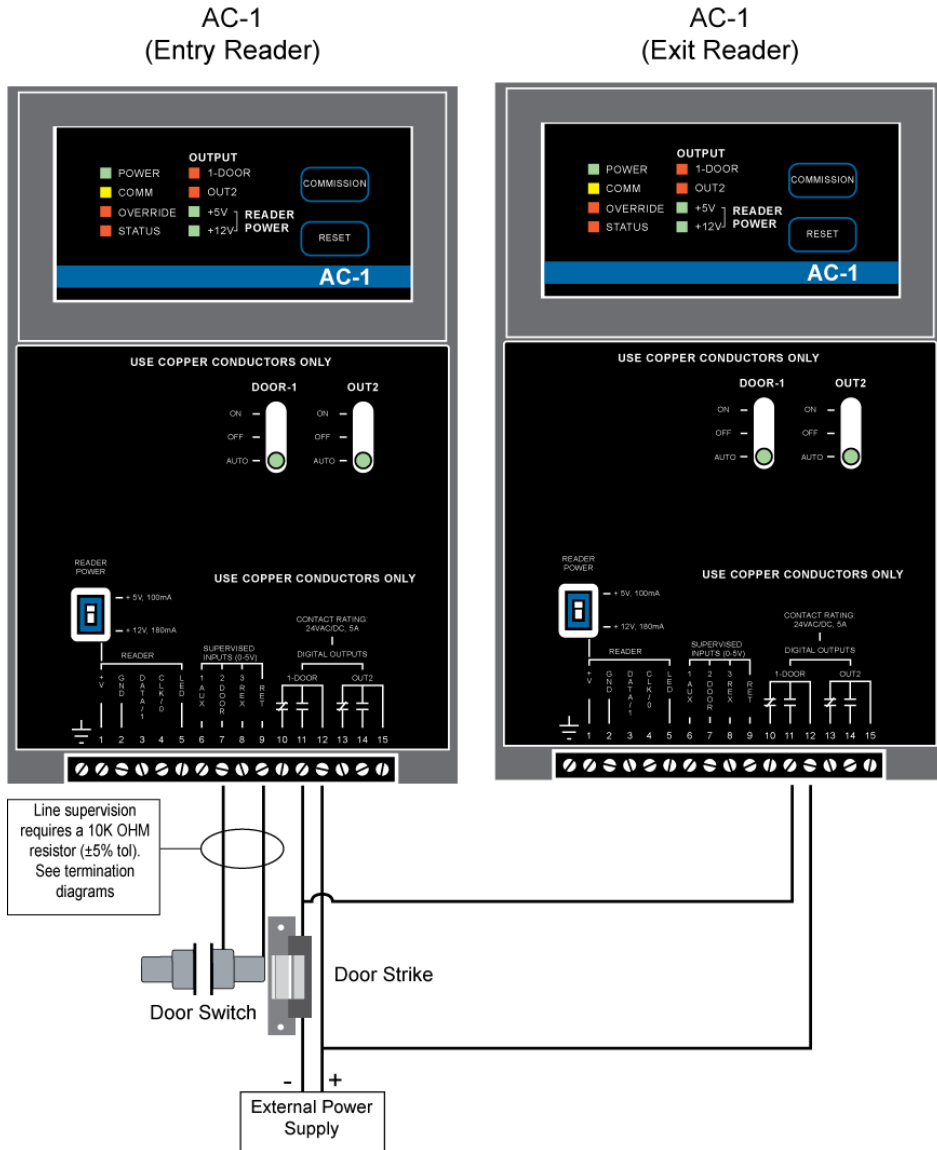

## Status/Control Panel

### Status Indicators

The AC-1 module includes a complete indicator status panel on the front of the module.

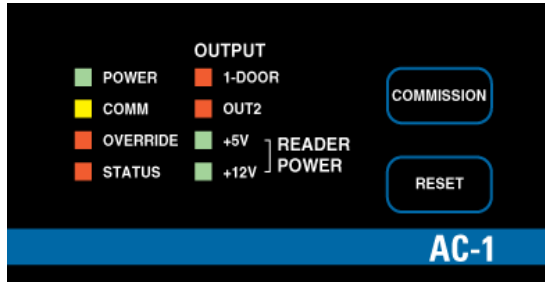

This panel includes indicators reporting on the status of the following:

- POWER** This green indicator illuminates when DC power is applied through the I/O Bus.
- COMM** This yellow indicator illuminates when data is transmitted from the module to the NetController. In normal operation, data is only transmitted when an input value changes.
- This indicator will also flash periodically as the NetController checks the I/O bus.
- OVERRIDE** This red indicator illuminates whenever any of the override switches is in a position other than AUTO.
- STATUS** This red indicator is normally off. If it is always on or flashing at a fast rate, there is a problem with the module.
- This indicator can be manually illuminated from the CyberStation workstation or Command Terminal and used as a troubleshooting aid when locating a particular module.
- OUTPUT** These red indicators (one for each channel) illuminate when an output relay is energized.
- READER POWER**
- +5V, +12V** These green indicators illuminate when either voltage is selected as the reader power source.

This panel also includes two operator switches that perform the following:

- COMMISSION** After physical installation and during configuration through the CyberStation workstation or Command Terminal, pressing this button registers the module's address with the system. For more information, refer to the section on *Module Configuration* found earlier in this manual.
- RESET** Should the module become inoperable, pressing this button resets the module. It does not erase its memory.

## AC-1A Access Control Module

The AC-1A, Access Control Module, provides full I/O for an access controlled door or portal in one compact module. The AC-1A can be remotely located at a door reader for localized control and reduced wiring costs; or several AC-1A modules can be grouped together and DIN rail-mounted for centralized control.

The AC-1A provides a Wiegand card input for Wiegand and Proximity type cards, reading up to 64 bits per card. Reader power (5 volts) is provided to meet most card reader power requirements.

The AC-1A includes two 5 Amp, Form C relays—one for the door lock and a second for local alarm annunciation. Each output has an integral hand-off-auto switch for manual operation, and software feedback of the switch position.

Up to three supervised alarm inputs can be used for door status contacts, request-to-exit devices, a cabinet tamper switch, and any other two-state or three-state (on/off/trouble) alarm device.

### Keypad Control

The AC-1A supports Wiegand output keypads. To simplify installation and reduce wiring costs, the AC-1A has a second set of connections.

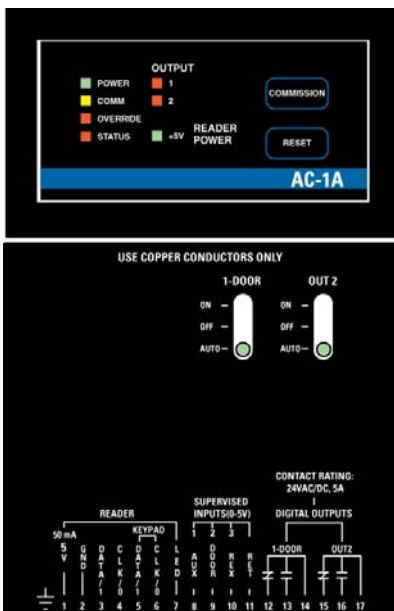

### FEATURES

- 1 Card Reader Input\*
- 1 Keypad Input\*
- \* Only one of these two devices can be active at any given moment.
- +5 V reader power
- 1 Card Reader LED control output
- Up to 3 Supervised Inputs
- 2 FormC Relay Outputs rated 24 VAC/DC @ 5A
- Override Toggle Switches w/Override Detection and Feedback
- 10–28 V Power Supply Range



## SPECIFICATIONS

### ELECTRICAL

<b>Power Supply Range:</b>	Input Voltage Range: 10-28V. 24V for UL864 and UL294 installations.
<b>Power Consumption:</b>	2.0 Watts + (Input Voltage) * (Reader Current) max. @ 24 VDC; normally provided by Andover Continuum power supply module.
<b>Overload Protection:</b>	0.5 A resettable fuse with transient voltage suppressor (TVS) and reverse polarity protection

### INPUTS/OUTPUTS

#### Inputs

<b>Card Readers:</b>	1*
<b>Keypads:</b>	1*
<b>Card Reader Type:</b>	Wiegand and Proximity readers
<b>Maximum Number of bits/Card:</b>	64
<b>Card Reader Power:</b>	+5 V ( $\pm 3\%$ ) @50 mA (max.)
<b>Wiring Distance:</b>	
<b>To Card Reader:</b>	500 ft. max. using 18-gauge wire 200 ft. max. using 22-gauge wire
<b>Alarm Inputs:</b>	Up to 3 supervised inputs. Single or double resistor supervision, series or parallel.
<b>Input Protection:</b>	Transient Voltage Suppressor (TVS) on each input

\* Only one of these two devices can be active at any given moment.

#### Outputs

<b>Door Outputs:</b>	2 Form C relays
<b>Output Rating:</b>	24 VAC/VDC @ 5 Amp
<b>Reader LED Output:</b>	Open collector; up to 100 mA.
<b>Output Protection:</b>	5000 V isolation 270 V MOVs on each output
<b>Overrides:</b>	3-position manual override switch on each output for manual control of relay. LED override status indicator.
<b>Override Feedback:</b>	Override detection and software feedback provided for each output.

## I/O Connections

The actual I/O connections are located on an eighteen-position removable screw terminal connector located at the bottom of the module. Wires should enter from either the top or bottom wiring troughs, and outputs should come from the right side of the rack, inputs from the left (by convention).

The diagram below indicates where each output number is located in the terminal block.

### Connection Description

⏏	Earth Ground
1.	Reader +5V
2.	Reader GND
3.	Reader DATA (Wiegand I)
4.	Reader CLK (Wiegand 0)
5.	Keypad DATA (Wiegand I)
6.	Keypad CLK (Wiegand 0)
7.	Reader LED
8.	Sup Input 1 Aux
9.	Sup Input 2 Door
10.	Sup Input 3 REX
11.	Sup Input RETURN
12.	1-Door NC
13.	1-Door NO
14.	1-Door COM
15.	OUT2 NC
16.	OUT2 NO
17.	OUT2 COM

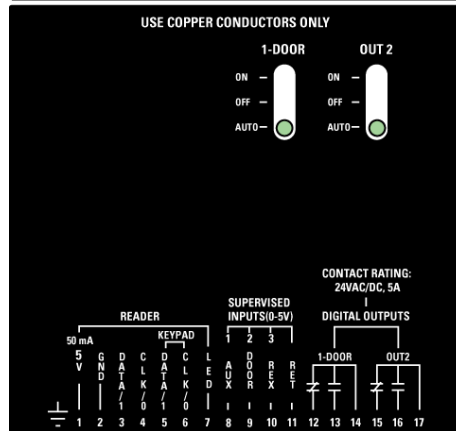
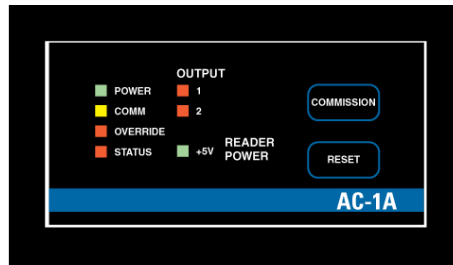

## Using the AC-1A

AC-1A is a complete card access control module designed to interface with the Schneider Electric NetController where an internal firmware-based Access Control supervisor resides. During normal operation, access control decisions are made in the Andover Continuum NetController CPU module database, which provides storage for up to 75,000 “local” personnel records (up to 4 million records may be created per database).

The AC-1A is designed to control a single door. The door can be configured to allow entrance based on card only, card plus personal ID number (PIN), or keypad only. The door’s operating mode can even be changed based on time-of-day or other events for optimum flexibility through Schneider Electric’s easy-to-use *Plain English* programming language. Each keypad can also permit entry of a duress alarm code that can initiate an alarm sequence at any AC-1A controller or at the CyberStation workstation.

Time-based anti-passback and entry/egress anti-passback are available to prevent tailgating. Entry/egress anti-passback is system-wide and can be performed by readers located on different AC-1A controllers across the network.

Using *Plain English*, the AC-1A can also be used for custom access control sequences such as two-man rule, optical turnstile control, and man trap configurations.

The AC-1A also supports inverted door output installations.

## Degrade Mode

If network communications are interrupted, as a fail-safe mode, the AC-1A will revert to a programmable degraded mode of operation. System operation during degrade mode provides uninterrupted card access using site codes, cards formats, and other degrade mode parameters stored in non-volatile EEPROM in each AC-1A module.

Degrade mode parameters are configured from the “Access Validation” section of the door editor’s “Entry Reader” tab. For dual reader doors, configurable degrade mode parameters are available from the “Access Validation” section of the door editor’s “Exit Reader” tab.

During degrade mode, the AC-1A module supports:

- Two of the site codes entered on the “Card Formats” tab of the door editor (out of four supported by the door during normal operation). The site codes supported are Site1 and Site2.
- One card type (determined below)

**Note:** In the NetController version 1.4 and forward, when more than one card type is selected at the door, the following procedure determines which one of the card types the AC-1A stores for degrade mode operation:

1. Open the door editor and de-select all card types except the one that you want the AC-1A to store for degrade mode operation.
2. Save the door settings by clicking “Apply”.
3. Select the other card types that will be allowed at the door in normal operation.
4. Save the door settings again by clicking “Apply” or “OK” to save and close the door editor.

## Connecting a Reader/Keypad

### Reader/Keypad Inputs

The AC-1A includes a full interface to a single Wiegand access card reader and a keypad. The modules were designed to allow Integral reader/keypad units to be connected directly. Separate keypads that have similar interfaces (Wiegand) can be connected through the keypad connections provided on the terminal block.

The Wiegand reader, keypad and/or reader/keypad unit is connected to the AC-1A module as shown below:

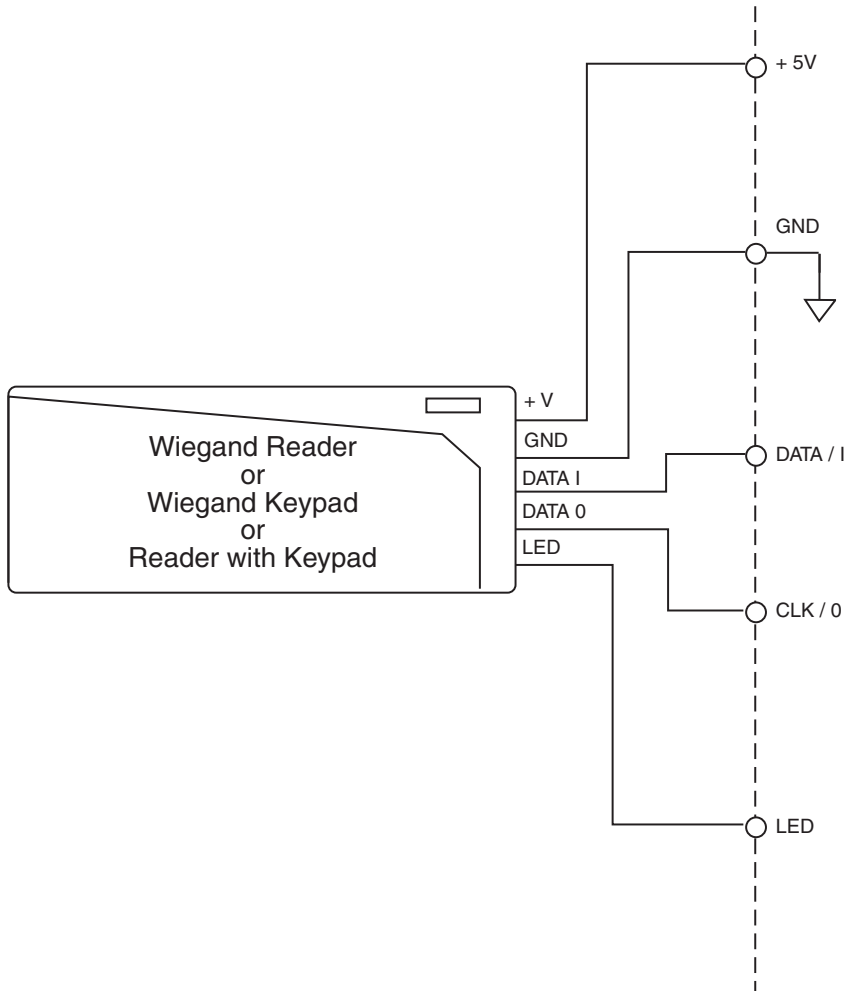

## Connecting Two Readers or a Keypad and a Reader

The AC-1A can interface to both a keypad and a reader simultaneously. This assumes that they are both Wiegand devices of similar voltage range.

Similarly, two readers can be connected. This allows a site to slowly introduce a different type of reader (i.e., proximity) while allowing access through the normal reader. The connections are as shown below:

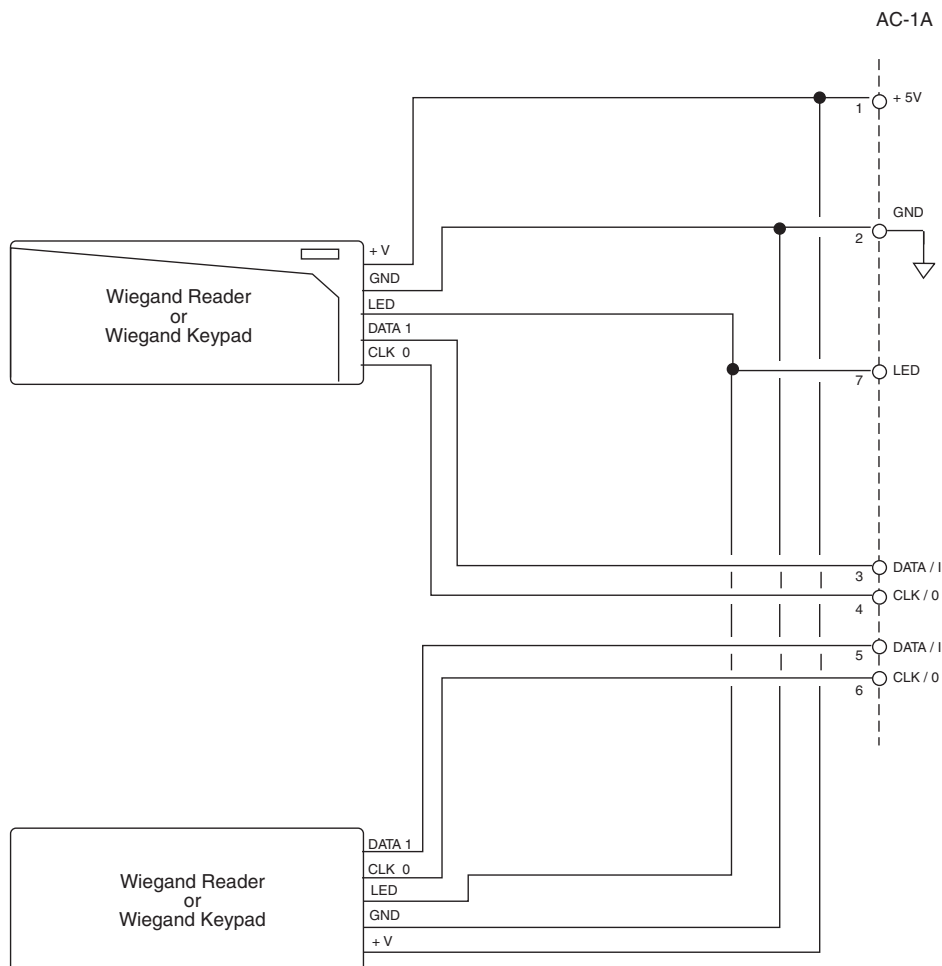

### Connecting Two Readers for a Dual Reader Door

With the addition of another AC-1A module, a door can be configured as a dual reader door. A door is a dual reader door when it has been configured with an entry and exit IOU module.

A dual reader door is connected as shown below:

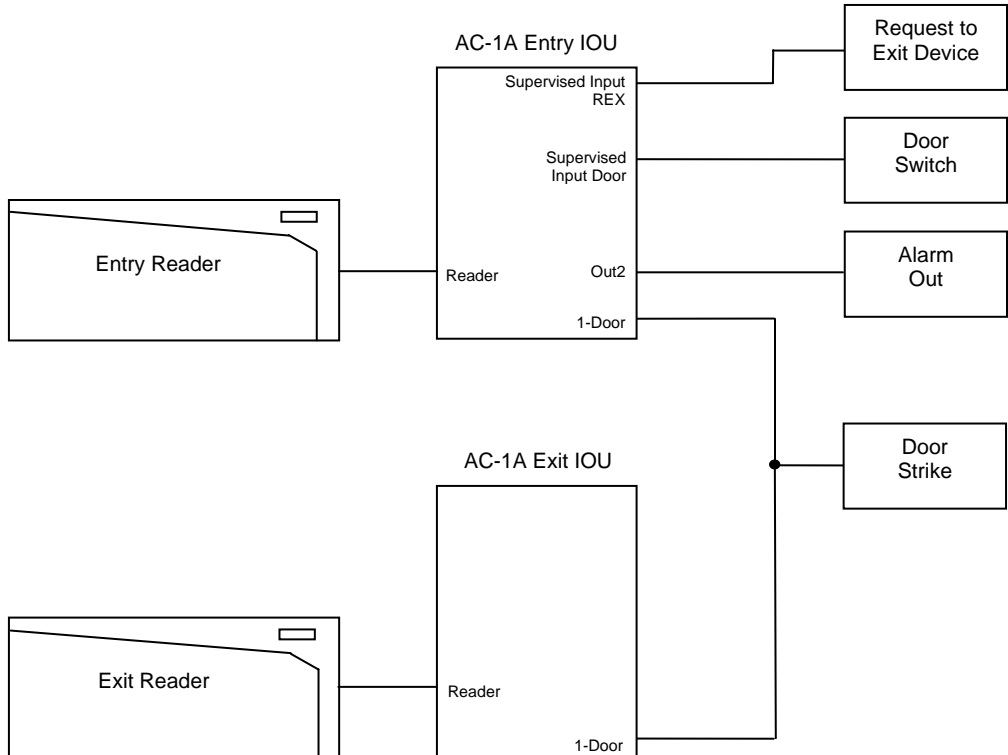

**Note:**

**As the door switch connects only to the Entry IOU, the door switch operation at the Exit IOU is not supported in degrade mode.**

## Connecting Supervisory Inputs

All AC-1A inputs are supervisory inputs. The following drawings depict the three types of supervisory inputs that exist—two normally closed and one normally open type.

**NOTE:** All resistor values are to be  $10K \pm 5\%$ .

### Normally Closed Supervised Inputs

#### NC Series

With this type of input wiring, a resistor is placed in series with the input being monitored. When the input contact presents a short circuit (normal closed position), the input is assumed to be in a normal closed state, the circuit presents a reading of  $10 K \Omega$ s at the input.

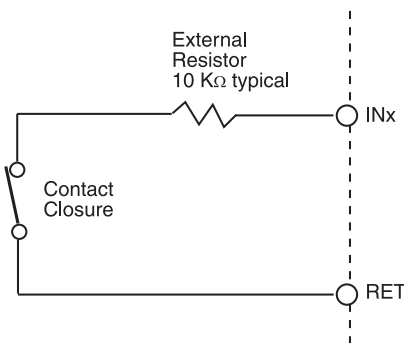

Circuit Action	Input Senses	Condition
Switch Closed	External Resistance	Input contact Closed
Switch Opened	Infinite Resistance	Input contact Open
Wire Cut	Infinite Resistance	Input contact Open 'Violation'
Input Shorted	Zero $\Omega$ s	Violation or error

When the input contact is opened, the circuit opens and an infinite resistance is measured. If the wires to the input contact are cut it also appears as an “input contact open” condition. In this case there would be an input contact open without a valid card swipe or valid keypad entry resulting in an “input contact violation”. Shorting the input causes a zero  $\Omega$  resistance, which also results in an input contact violation.

When configuring for this type of contact select:

**ElecType:**        **Supervised**  
**Resistor Type:** **NCSeries**



## Normally Closed Supervised Inputs

### NC Series Parallel

With this type of input wiring, two external resistors are added to the input, one in series and the other in parallel. When the input contact switch is closed (normal position), the input contact is assumed to be closed. The circuit presents a reading composed of both resistances in parallel that works out to be half the value of one of them (5 K $\Omega$ ).

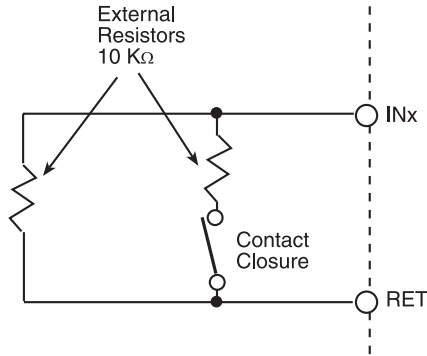

Circuit Action	Input Senses	Condition
Switch Closed	External Resistance $\div 2$	Input contact Closed
Switch Opened	External Resistance	Input contact Open
Wire Cut	Infinite Resistance	Violation or error
Input Shorted	Zero $\Omega$ s	Violation or error

When the input contact is opened, the switch opens and the value of the parallel resistor is measured. If the wires to the input contact are cut it appears as an infinite resistance. Shorting the input causes a zero  $\Omega$  resistance. Both a short and an infinite resistance (open) should result in an error condition.

When configuring for this type of contact select:

**ElecType:**        **Supervised**  
**Resistor Type:**   **NCSerPar**

## Normally Open Supervised Inputs

### **NO Series Parallel**

With this type of input wiring, two external resistors are added to the input, one in series and the other in parallel. When the input contact switch is open (normal position) the input contact is assumed to be closed. The circuit reads the value of the parallel resistor.

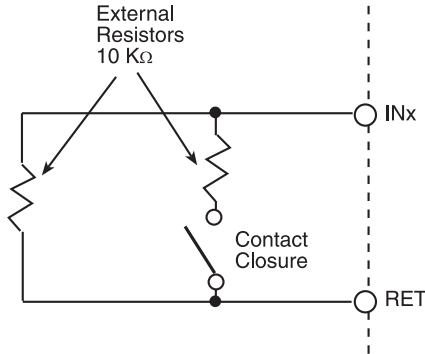

#### **Circuit Action**

Switch Closed  
 Switch Opened  
 Wire Cut  
 Input Shorted

#### **Input Senses**

External Resistance  $\div 2$   
 External Resistance  
 Infinite Resistance  
 Zero  $\Omega$ s

#### **Condition**

Input contact Open  
 Input contact Closed  
 Violation or error  
 Violation or error

When the input contact is opened the switch closes and a reading results that is composed of both resistances in parallel that works out to be half the value of one of them (5 K $\Omega$ ). If the wires to the input contact are cut it appears as an infinite resistance. Shorting the input causes a zero  $\Omega$  resistance. Both a short and an infinite resistance (open) should result in an error condition.

When configuring for this type of contact select:

**ElecType:**        **Supervised**  
**Resistor Type:** **NOSeriPar**

### Wiring Door Switches

There are three supervisory inputs for door switches. The maximum length wire you can use is 500 ft of #18 gauge wire (152 m of 1.0 mm<sup>2</sup> wire) or 200 ft of #22 gauge wire (60 m of 0.35 mm<sup>2</sup> wire).

Some switches have built-in resistors that facilitate Series Parallel connections as shown below:

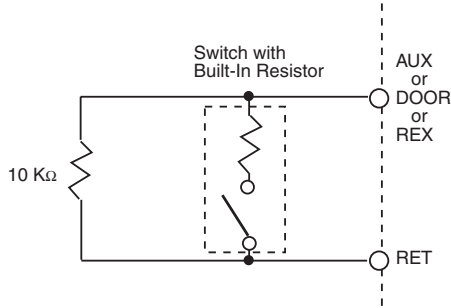

### Wiring Motion Detectors

Motion detectors are devices that close a switch contact when motion is detected.

Wiring is similar to a normal door switch input, however, the motion sensor requires an external power supply of 12 VDC or 24 VDC (UL listed under APHV). The maximum length wire you may use is 500 ft of #18 gauge wire (152 m of 1.0 mm<sup>2</sup> wire) or 200 ft of #22 gauge wire (60 m of 0.35 mm<sup>2</sup> wire).

The following shown a typical motion detector circuit:

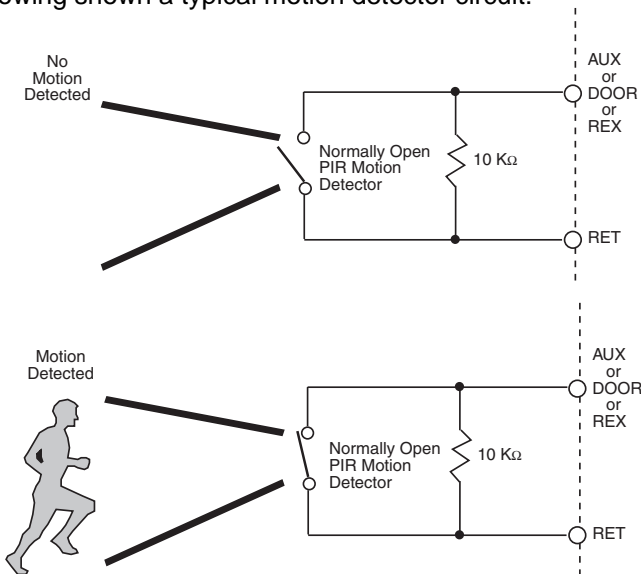

## Connecting Outputs

The AC-1A module includes two Form C single-pole double-throw relay outputs. The following is a simplified schematic of each output channel:

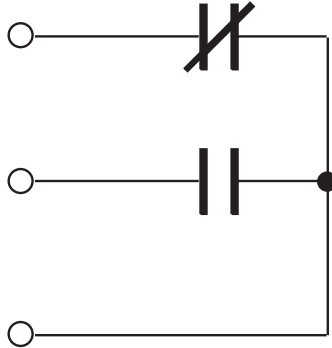

Both channels resemble the circuit shown above.

To use the Form C output in your system, configure an output point with an Electrical Type of **Digital**.

These output contacts operate as a standard relay. When the output is set to an “ON” state, the normally open contacts close and the normally closed contacts open.

**NOTE:** When configuring a Digital point, there is a ‘Polarity’ attribute. If this attribute is enabled, the operation of the outputs are reversed.

## Override Controls

The AC-1A module includes an output override switch for each output.

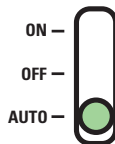

The output of the module can be directed from program control or manual control. The output can be disabled completely as well.

The following describes the actions associated with each position of the override controls:

- ON**                    The output relay is energized to an “ON” state manually by setting the switch to ON. Programs have no effect on the output when the switch is in this position.
  
- OFF**                    The output relay is de-energized to an “OFF” state manually by setting the switch to OFF. Programs have no effect on the output when the switch is in this position.
  
- AUTO**                    The action of the output relay is determined as a direct result of program control.

### Wiring Door Outputs

The following represents a typical door output installation when the circuit is normally open:

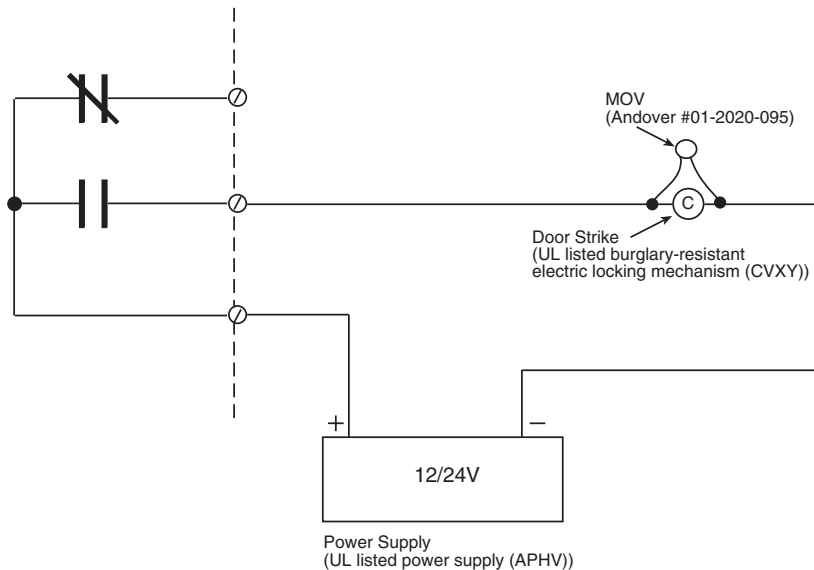

This configuration shows a normally de-energized lock (when secured) in a fail secure mode. If power loss occurs, the lock closes. Always be sure to use “panic” hardware that allows emergency exit from the secured area.

The following represents a typical door output installation when the circuit is normally closed:

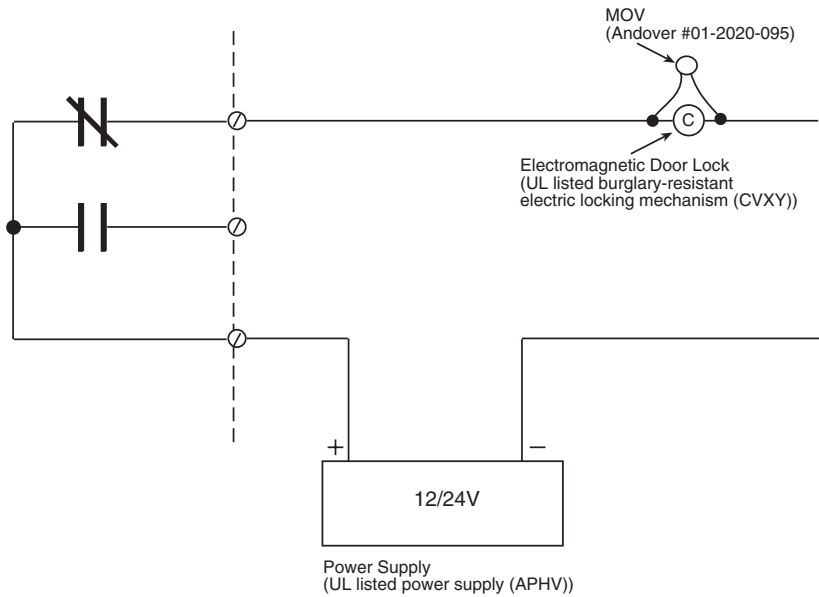

This configuration shows a normally de-energized lock (when secured), in a fail safe mode. If power loss occurs, the lock opens.

## Wiring Dual Reader Door Outputs

The following represents a typical door output installation when the dual reader door circuit is controlling a fail-secure lock:

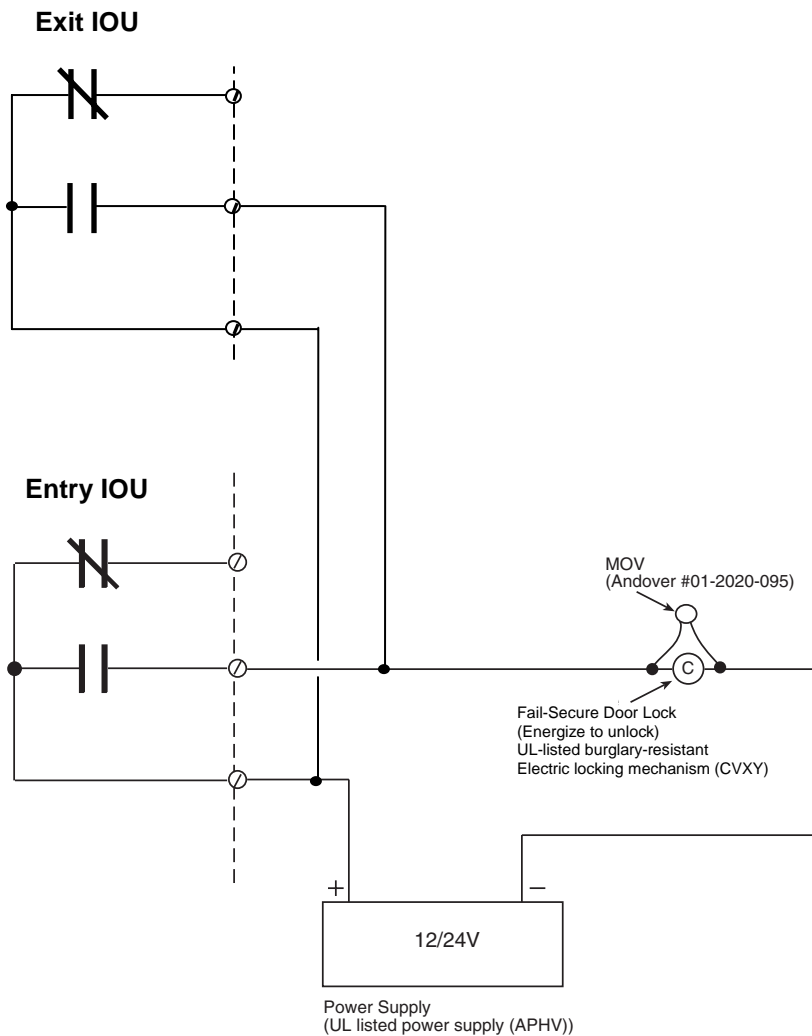

The following represents a typical door output installation when the dual reader door circuit is controlling a fail-safe lock:

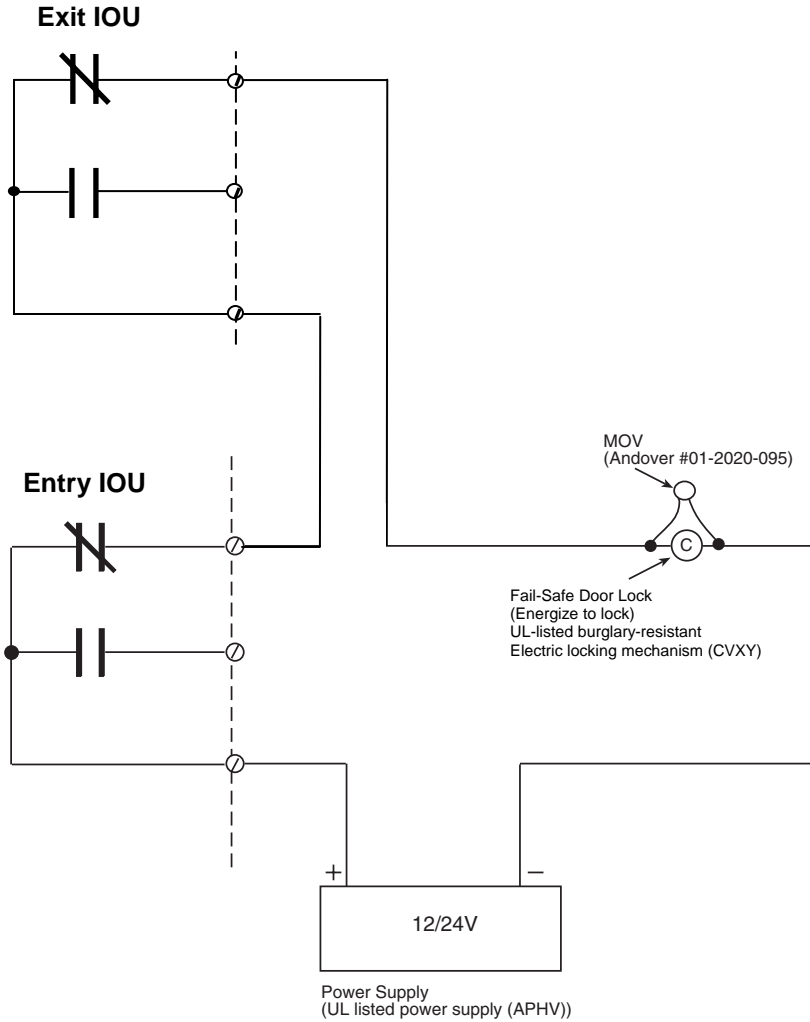



## Status/Control Panel

### Status Indicators

The AC-1A module includes a complete indicator status panel on the front of the module.

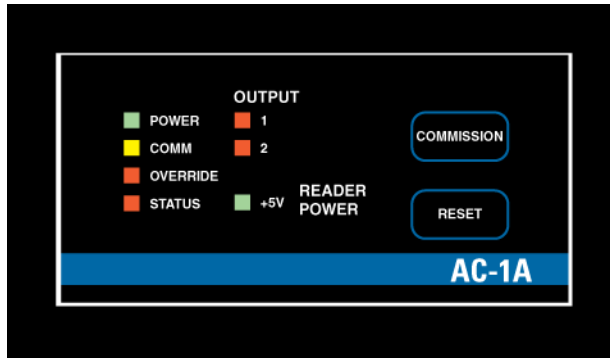

This panel includes indicators reporting on the status of the following:

- POWER** This green indicator illuminates when DC power is applied through the I/O Bus.
- COMM** This yellow indicator illuminates when data is transmitted from the module to the NetController. In normal operation, data is only transmitted when an input value changes.
- This indicator will also flash periodically as the NetController checks the I/O bus.
- OVERRIDE** This red indicator illuminates whenever any of the override switches is in a position other than AUTO.
- STATUS** This red indicator is normally off. If it is always on or flashing at a fast rate, there is a problem with the module.
- This indicator can be manually illuminated from the CyberStation workstation or Command Terminal and used as a troubleshooting aid when locating a particular module.
- OUTPUT** These red indicators (one for each channel) illuminate when an output relay is energized.
- READER POWER**
- +5V** This green indicator illuminates when the reader power source is operational.

This panel also includes two operator switches that perform the following:

**COMMISSION** After physical installation and during configuration through the CyberStation workstation or Command Terminal, pressing this button registers the module's address with the system. For more information, refer to the section on *Module Configuration* found earlier in this manual.

**RESET** If the module becomes inoperable, pressing this button resets the module. It does not erase its memory.

## AC-1 Plus Access Control Module

The AC-1 Plus, Access Control Module, provides full I/O for an access controlled door or portal in one compact module. The AC-1 Plus can be remotely located at a door reader for localized control and reduced wiring costs; or several AC-1 Plus modules can be grouped together and DIN rail-mounted for centralized control.

The AC-1 Plus provides a reader input connection for Wiegand/ABA/CK34 and Proximity type cards, reading up to 64 bits per card for Wiegand cards and 255 bits per card for ABA cards. Reader power (5 volts) is provided to meet most card reader power requirements.

The AC-1 Plus includes two 5 Amp, Form C relays—one for the door lock and a second for local alarm annunciation. Each output has an integral hand-off-auto switch for manual operation, and software feedback of the switch position.

Up to five supervised alarm inputs can be used for door status contacts, ADA request-to-exit devices, a cabinet tamper switch, and any other two-state or three-state (on/off/trouble) alarm device.

### Keypad Control

The AC-1Plus supports Wiegand output keypads. To simplify installation and reduce wiring costs, the keypad data comes into the module via the reader data lines.

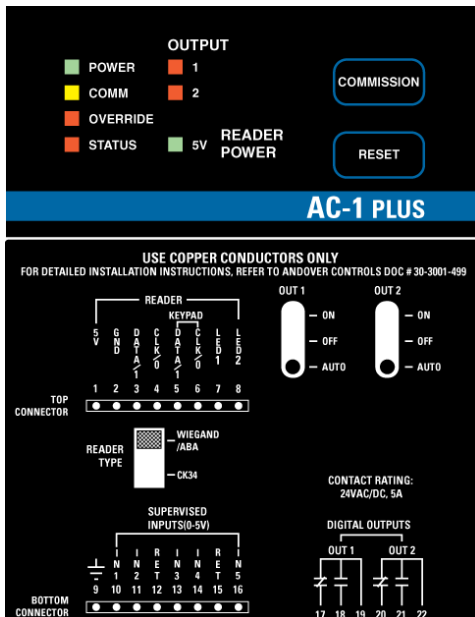

### FEATURES

- 1 Card Reader Input\*
- 1 Keypad Input\*
  - ♦ \*Only one of these two devices can be active at any given moment.
- Wiegand/ABA or CK34 formats supported
- +5 V reader power
- 2 Card Reader LED control outputs
- Up to 5 Supervised Inputs
- 2 FormC Relay Outputs rated 24 VAC/DC @ 5A
- Override Toggle Switches w/Override Detection and Feedback
- Supports Bond Sensor and ADA input switches

## SPECIFICATIONS

### ELECTRICAL

<b>Power Supply Range:</b>	Input Voltage Range: 10-28V. 24V for UL294 installations.
<b>Power Consumption:</b>	2.2 Watts + (Input Voltage) * (Reader Current) max. @ 24 VDC; normally provided by Andover Continuum power supply module.
<b>Overload Protection:</b>	0.5 A resettable fuse with transient voltage suppressor (TVS) and reverse polarity protection

### INPUTS/OUTPUTS

#### Inputs

<b>Card Readers:</b>	1*
<b>Keypad:</b>	1*

\* Only one of these two devices can be active at any given moment.

<b>Card Reader Type:</b>	Wiegand, ABA or CardKey (switch selectable) **
<b>Maximum Number of bits/Card:</b>	64 (Wiegand) 255 (ABA)
<b>Card Reader Power:</b>	+5 V ( $\pm 3\%$ ) @50 mA (max.)
<b>Wiring Distance</b>	
<b>Card Reader to AC-1 Plus:</b>	500 ft. max. using 18-gauge wire 200 ft. max. using 22-gauge wire
<b>Alarm Inputs:</b>	Up to 5 supervised inputs. Single or double resistor supervision, series or parallel.
<b>Input Protection:</b>	Transient voltage suppressor (TVS) on each input

\*\* The following reader and keypad models are the only approved devices for use in UL 294 Access Control applications:

Essex KTP-163-SN keypad; HID Epic 32985 Wiegand reader; Indala ASR-500 Wiegand reader.

#### Outputs

<b>Door Outputs:</b>	2 Form C relays
<b>Output Rating:</b>	24 VAC/VDC @ 5 Amp
<b>Reader LED Output:</b>	(2) each, open collector; up to 100 mA.
<b>Output Protection:</b>	5000 V isolation 270 V MOVs on each output
<b>Overrides:</b>	3-position manual override switch on each output for manual control of relay. LED override status indicator.
<b>Override Feedback:</b>	Override detection and software feedback provided for each output.

## I/O Connections

The actual I/O connections are located on a sixteen-position removable screw terminal connector located at the bottom of the module. Wires should enter from either the top or bottom wiring troughs, and outputs should come from the right side of the rack, inputs from the left (by convention).

The diagram below indicates where each output number is located in the terminal block.

Connection	Description
1.	Reader +5V
2.	Reader GND
3.	Reader DATA (Wiegand I)
4.	Reader CLK (Wiegand 0)
5.	Keypad DATA (Wiegand I)
6.	Keypad CLK (Wiegand 0)
7.	Reader LED1
8.	Reader LED2
9.	Earth Ground
10.	IN1
11.	IN2
12.	RET
13.	IN3
14.	IN4
15.	RET
16.	IN5
17.	OUT1 NC
18.	OUT1 NO
19.	OUT1 COMM
20.	OUT2 NC
21.	OUT2 NO
22.	OUT2 COMM

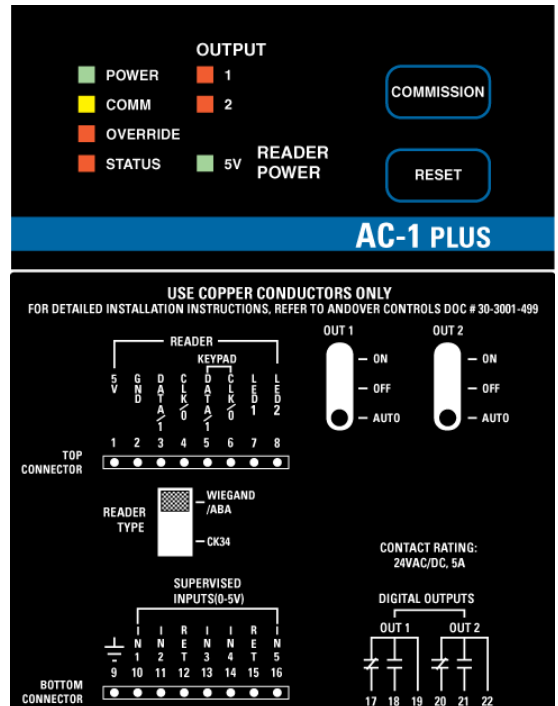

## Using the AC-1 Plus

AC-1 Plus is a complete card access control module designed to interface with the Schneider Electric NetController where an internal firmware-based Access Control supervisor resides. During normal operation, access control decisions are made in the Andover Continuum NetController CPU module database, which provides storage for up to 75,000 “local” personnel records (up to 4 million records can be created per database).

The AC-1 Plus is designed to control a single door. The door can be configured to allow entrance based on card only, card plus personal ID number (PIN), or keypad only. The door’s operating mode can even be changed based on time-of-day or other events for optimum flexibility through Schneider Electric’s easy-to-use *Plain English* programming language. Each keypad can also permit entry of a duress alarm code that can initiate an alarm sequence at any AC-1 Plus controller or at the Andover Continuum CyberStation.

The AC-1 Plus also supports ADA (Alternate Door Access) and inverted door output installations and *Bond Sensor* circuitry. A bond sensor detects the actual status (locked or unlocked) of the door.

Time-based anti-passback and entry/egress anti-passback are available to prevent tailgating. Entry/egress anti-passback is system-wide and can be performed by readers located on different AC-1 and AC-1 Plus controllers across the network.

Using *Plain English*, the AC-1 Plus can also be used for custom access control sequences such as two-man rule, optical turnstile control, and man trap configurations.

### Reader Power

The AC-1 Plus module supports 5 volt DC readers.

### Reader Type Switch

The AC-1 Plus supports three card formats. The Reader Type switch selects either Wiegand/ABA or CardKey (CK34) format.

## Degrade Mode

If network communications are interrupted, as a fail-safe mode, the AC-1 Plus will revert to a programmable degraded mode of operation. System operation during degrade mode provides uninterrupted card access using site codes, cards formats, and other degrade mode parameters stored in non-volatile EEPROM (such as the settings of the AccessLEDPattern Numeric) in each AC-1 Plus module.

Degrade mode parameters are configured from the “Access Validation” section of the door editor’s “Entry Reader” tab. For dual reader doors, configurable degrade mode parameters are available from the “Access Validation” section of the door editor’s “Exit Reader” tab.

During degrade mode, the AC-1 Plus module supports:

- All four site codes entered on the “Card Formats” tab of the door editor
- All card types selected on the “Card Formats” tab of the door editor
- ADA functionality
- General codes (Keypad)
- Door Switch operation on both the Entry and Exit IOU of a dual-reader door

## Reader LED Pattern

For the AC-1 Plus, the LED pattern of the reader is determined by the creation of an InfinityNumeric called AccessLEDPattern. The settings are described as follows:

### Schneider Electric LED Pattern (AccessLEDPattern = 0)

This pattern is transaction based, meaning the reader LED indicates the state of the access transaction.

ReaderLED	Description
Solid Red	No door configured on this reader channel. The system will not process any transaction coming from this reader
Solid Green	Door configured on this reader channel. System is ready to process an access transaction (i.e. card swipe)
Solid Red for 3 seconds following an access transaction	Invalid Attempt
Rapid Flashing following an access transaction	Valid Access
Slow Flashing following an access transaction	System is waiting for information needed to process the transaction. I.e. Transaction is being processed (remote validation) or the system is waiting for user entry (PIN needed after card swipe).

---

**NOTE1:** Starting in V1.1, LED2 will turn ON whenever the door is open. This can be used to control another indicator LED, such as a keypad LED.

**NOTE2:** A manual override does not affect the Reader LED for the Schneider Electric LED pattern.

---



**Alternate LED Pattern (AccessLEDPattern = 1)**

This pattern follows the state of the door lock itself.

<b>ReaderLED</b>	<b>Description</b>
Solid Red	Door is locked
Solid Green	Door is unlocked
Rapid Flashing following an access transaction	Invalid attempt
Slow Flashing following an access transaction	System is waiting for information needed to process the transaction. I.e. Transaction is being processed. (remote validation) or the system is waiting for user entry. (PIN needed after card swipe)

---

**NOTE:** Starting in V1.1, LED2 will turn ON whenever the door is open. This can be used to control another indicator LED, such as a keypad LED.

---

## CardKey LED Pattern (AccessLEDPattern = 2)

ReaderLED – Red	ReaderLED - Green	Description
OFF	OFF	Door is locked
OFF	ON	Door is unlocked
ON	OFF	Invalid attempt
Slow Flashing following an access transaction	OFF	System is waiting for information needed to process the transaction. I.e. Transaction is being processed. (remote validation) or the system is waiting for user entry. (PIN needed after card swipe)

---

**NOTE1:** The 12V incandescent lamp power is not provided by the AC-1plus.

**NOTE2:** The RED lamp is controlled by the LED1 output and the GREEN lamp is controlled by the LED2 output.

---

**Dorado780 LED Pattern (AccessLEDPattern = 3)**

This LED pattern was designed to be used with the Dorado Model 780 ABA Reader/Keypad.

<b>“Slide Card” LED - Red</b>	<b>“Enter Code” LED – Amber</b>	<b>“Open Door” LED – Green</b>	<b>Description</b>
ON	OFF	OFF	Waiting for card swipe
Slow Flashing	OFF	OFF	System is validating the card swipe
OFF	ON	OFF	Waiting for PIN entry
OFF	Slow Flashing	OFF	System is validating the PIN entry
OFF	OFF	ON	Door is unlocked
Rapid Flashing	Rapid Flashing	OFF	Invalid attempt

---

**NOTE1:** The dipswitches on the Dorado Model 780 must be set for CLOCK/DATA operation.

**NOTE2:** The LED1 output on the AC-1plus is wired to the LED A input on the Dorado Model 780, and the LED2 output is wired to the LED B input.

---

### Entering an Input String at a Keypad for Use in PE Programs

From a keypad connected to an AC-1 Plus, you (the user) may also send additional data to a controller, which in turn passes it to a Plain English (PE) program for execution in an Andover Continuum control application. This capability enables you to use the keypad to send input to a PE program for any purpose.

For example:

- A user can enter a string that a PE program uses to turn lights or fans on or off, or to control other HVAC equipment.
- A user can enter a string indicating the user's purpose for entering an area. The PE program can capture this information as input to a PE program for tracking reasons for activity in a secure area.

### Handling String Input at the Controller

Before you can use the keypad for PE program input, you must create a Plain English program that processes the string entered at the keypad and returns a value to the AC-1 Plus based on the entry. In addition, you must create the following objects in the controller:

- An InfinityString object that stores the input from channel 7 of the AC-1 Plus and that your PE program reads to obtain the content of the string
- An InfinityOutput object that stores a numeric value specified in the PE program and sent to channel 4 of the AC-1 Plus (See "PE Feedback to the AC-1 Plus" later in this section.)

You can use Continuum Explorer in CyberStation to create the InfinityString and InfinityOutput objects in the controller.

### Entering String Input from Keypad

The process for entering string input at a keypad has the following steps:

1. The user presents a valid access card and/or PIN (if a PIN is required) to the door reader.
2. The controller for this reader accepts the user's credentials, and the door unlocks.
3. Within three seconds of the door unlocking, the user enters two consecutive asterisks ( \*\* ) at the keypad to enter escape sequence mode.

4. The keypad LED flashes slowly to indicate that it is waiting for input.
5. The user enters a numeric string of up to 30 characters (not including the two asterisks), and then terminates the string with the pound sign (#).

For example: \*\*10# or \*\*6986310#

6. The AC-1 Plus sends the string to the controller (and its PE program) via channel 7, the string input channel for Plain English.

### Entry Rules for String Input

The following rules apply to using a keypad connected to the AC-1 Plus to enter string input:

- After the door unlocks, if more than 3 seconds elapse before the user enters two asterisks, the AC-1 Plus exits escape sequence mode. The user must begin the process for string input again.
- If a user enters more than 30 characters (not including the first two asterisks), the AC-1 Plus detects when the 31<sup>st</sup> digit is entered. The AC-1 Plus then replaces the 30<sup>th</sup> character with T to indicate Tamper, and sends the string to the controller (no # is needed). Subsequent characters entered as part of the string are ignored.

For example, if the user enters \*\*123456789012345678901234567890123, the AC-1 Plus sends \*\*12345678901234567890123456789T to the controller.

- The user can enter asterisks within the string if needed. These asterisks are converted to periods when sent to the PE program.

For example: 69\*8\*6310 is converted to 69.8.6310 when sent to the PE program.

- If more than 4 seconds elapse between keystrokes, the AC-1 Plus exits escape sequence mode. The user must begin the process for string input again.
- If a user presents an access card to the card reader while the AC-1 Plus is in escape sequence mode, the AC-1 Plus exits escape sequence mode. The user must begin the process for string input again.

## PE Feedback to the AC-1 Plus

After the PE program receives the string input and interprets its value, the program assigns an appropriate value to the InfinityOutput object. One of the following values is transmitted back to the AC-1 Plus through channel 4:

- **1** – Clear string.
- **2** – Recognize the escape sequence entry (success).
- **3** – Do not recognize the escape sequence entry (fail).

**NOTE:** Clearing the string in the AC-1 Plus using the Clear String command is recommended after each string input in escape sequence mode.

Based on the numeric value returned to the AC-1 Plus through channel 4, the AC-1 Plus also uses the reader LEDs to indicate to the user whether or not the string input is valid or invalid. The LED pattern to indicate valid/invalid entry is the same as the selected access control LED pattern used to indicate valid/invalid card and PIN entry.

## Connecting a Reader/Keypad

### Reader/Keypad Inputs

The AC-1 Plus includes a full interface to a single Wiegand, ABA or CardKey access card reader. The module is designed to allow Integral reader/keypad units to be connected directly. Separate keypads that have similar interfaces can be connected in parallel with a reader by using the auxiliary input connector as shown on the following page.

The reader and/or reader/keypad unit is connected to the AC-1 Plus module as shown below:

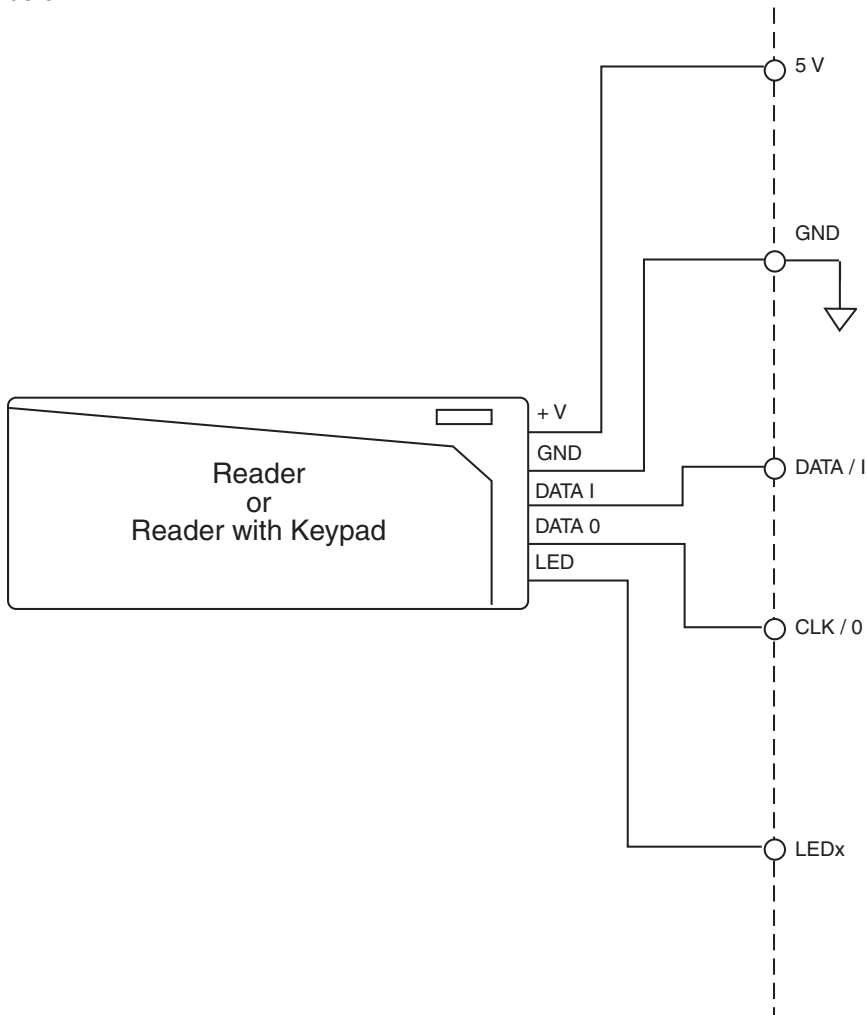

## Connecting Two Readers or a Keypad and a Reader

The AC-1 Plus can interface to both a keypad and a reader simultaneously. This assumes that they are both format compatible devices of similar voltage range.

Similarly, two readers can be connected. This allows a site to slowly introduce a different type of reader (i.e., proximity) while allowing access through the normal reader.

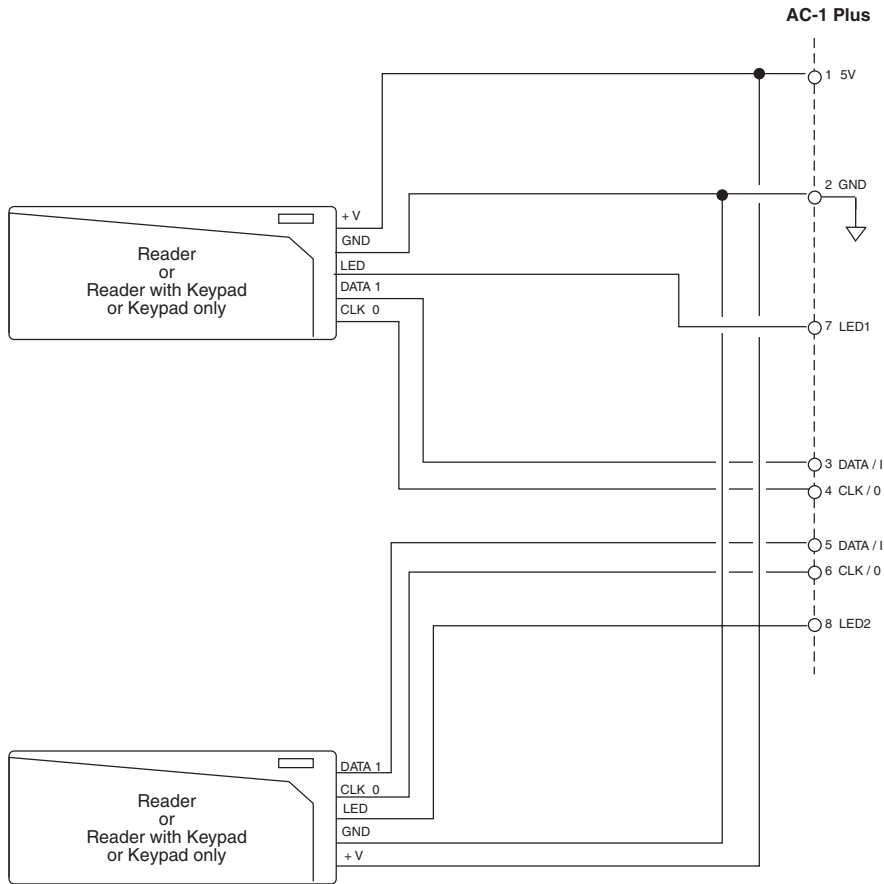



## Connecting a CardKey Reader

You can connect a CardKey reader directly to the AC-1 Plus, however, the CardKey reader requires a +12VDC supply for the red and green lamps. The AC-1 Plus does not supply 12 VDC, therefore it is necessary to connect an external power supply to provide the necessary power for the lamps.

Make sure the reader type switch is set to the CK34 position when using a CardKey reader.

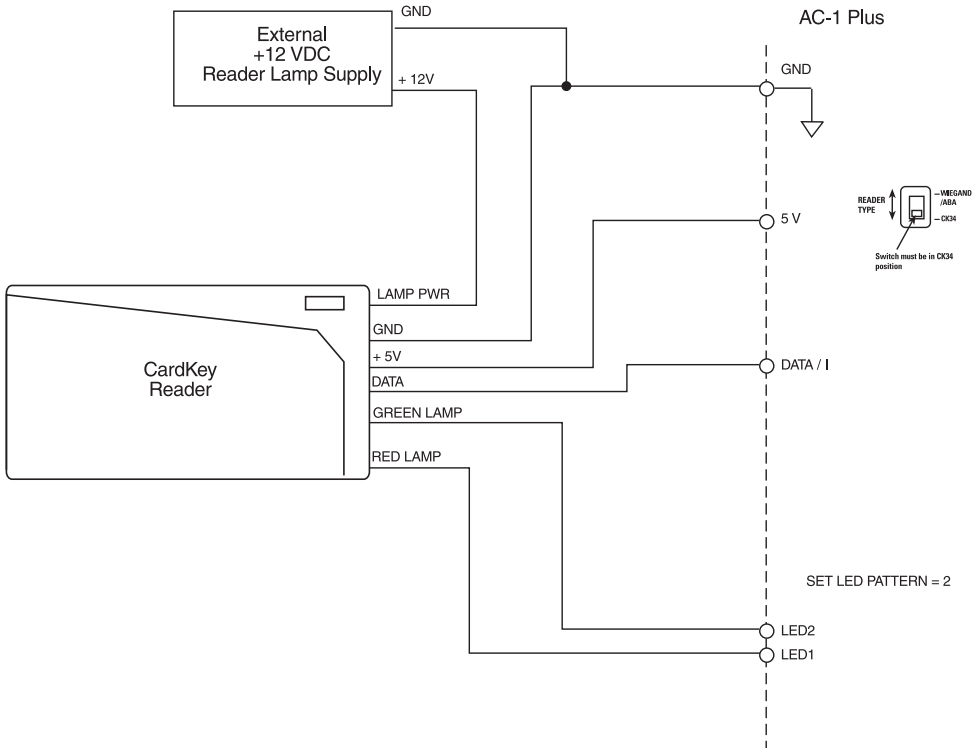

## Connecting Two Readers for a Dual Reader Door

With the addition of another AC-1 Plus module, a door can be configured as a dual reader door. A door is a dual reader door when it has been configured with an entry and exit IOU module.

A dual reader door is connected as shown below:

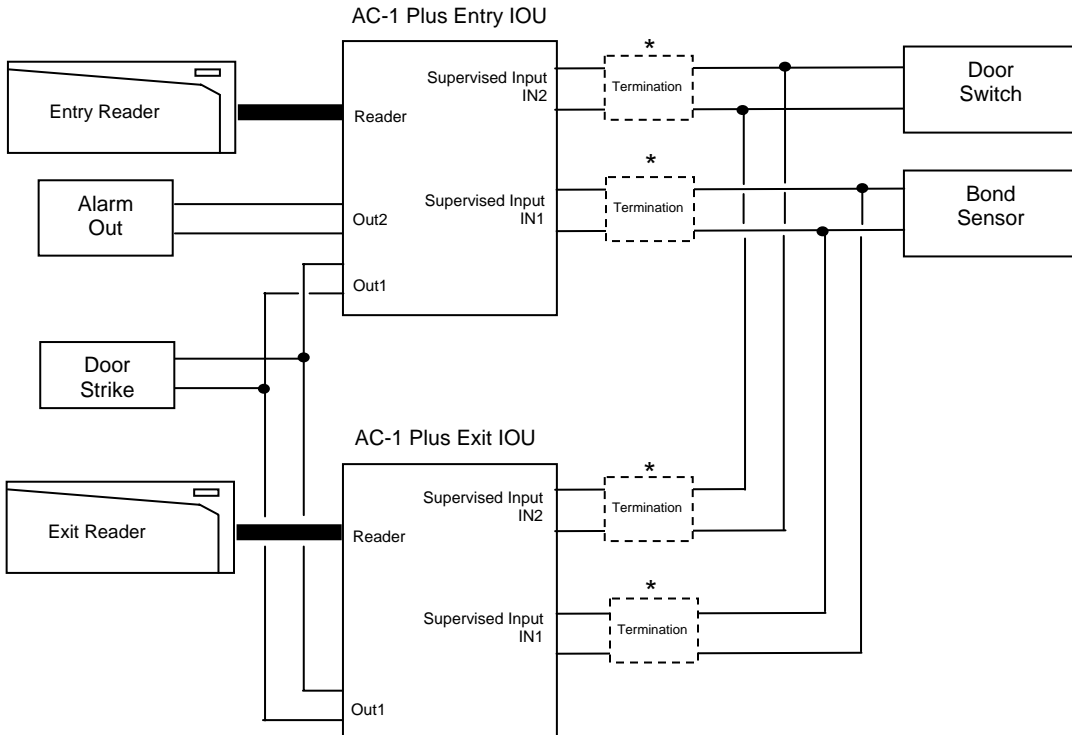

### \* TERMINATION

Each input must be terminated using your chosen Supervised Input resistor arrangement. It is important that **BOTH AC-1 Plus** modules include termination where they share door switches and/or Bond sensors.

For more information on input termination, refer to the section on Supervised Inputs.

## Connecting Supervisory Inputs

All AC-1 Plus inputs are supervisory inputs. The following drawings depict the three types of supervisory inputs that exist—two normally closed and one normally open type.

**NOTE:** All resistor values are to be  $10\text{K}\Omega \pm 5\%$ .

### Normally Closed Supervised Inputs

#### NC Series

With this type of input wiring, a resistor is placed in series with the input being monitored. When the input contact presents a short circuit (normal closed position) the input is assumed in a normal closed state, the circuit presents a reading of  $10\text{K}\Omega$ s at the input.

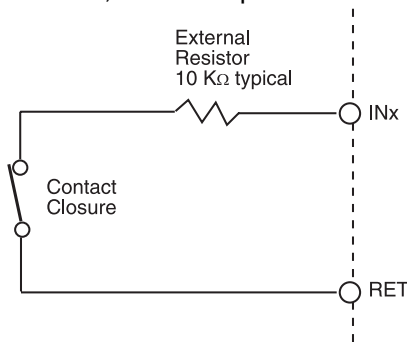

Circuit Action	Input Senses	Condition
Switch Closed	External Resistance	Input contact Closed
Switch Opened	Infinite Resistance	Input contact Open
Wire Cut	Infinite Resistance	Input contact Open 'Violation'
Input Shorted	Zero $\Omega$ s	Violation or error

When the input contact is opened, the circuit opens and an infinite resistance is measured. If the wires to the input contact are cut it also appears as an “input contact open” condition. In this case there would be a input contact open without a valid card swipe or valid keypad entry resulting in an “input contact violation”. Shorting the input causes a zero  $\Omega$  resistance, which also results in an input contact violation.

When configuring for this type of contact select:

**ElecType:**        **Supervised**  
**Resistor Type:** **NCSeries**

## Normally Closed Supervised Inputs

### **NC Series Parallel**

With this type of input wiring, two external resistors are added to the input, one in series and the other in parallel. When the input contact switch is closed (normal position) the input contact is assumed to be closed. The circuit presents a reading composed of both resistances in parallel that works out to be half the value of one of them (5 K $\Omega$ ).

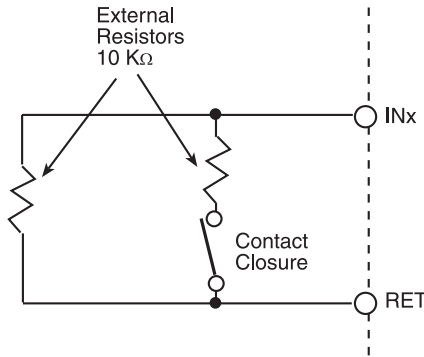

Circuit Action	Input Senses	Condition
Switch Closed	External Resistance $\div 2$	Input contact Closed
Switch Opened	External Resistance	Input contact Open
Wire Cut	Infinite Resistance	Violation or error
Input Shorted	Zero $\Omega$ s	Violation or error

When the input contact is opened the switch opens and the value of the parallel resistor is measured. If the wires to the input contact are cut it appears as an infinite resistance. Shorting the input causes a zero  $\Omega$  resistance. Both a short and an infinite resistance (open) should result in an error condition.

When configuring for this type of contact select:

**ElecType:**        **Supervised**  
**Resistor Type:** **NC SerPar**



## Wiring Door Switches

There are three supervisory inputs for door switches. The maximum length wire you may use is 500 ft of #18 gauge wire (152 m of 1.0 mm<sup>2</sup> wire) or 200 ft of #22 gauge wire (60 m of 0.35 mm<sup>2</sup> wire).

Some switches have built-in resistors that facilitate Series Parallel connections as shown below:

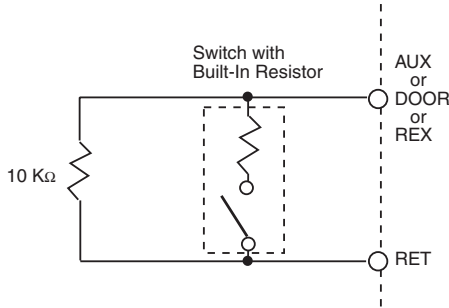

## Wiring Motion Detectors

Motion detectors are devices that close a switch contact when motion is detected.

Wiring is similar to a normal door switch input, however, the motion sensor requires an external power supply of 12 VDC or 24 VDC (UL listed under APHV). The maximum length wire you may use is 500 ft of #18 gauge wire (152 m of 1.0 mm<sup>2</sup> wire) or 200 ft of #22 gauge wire (60 m of 0.35 mm<sup>2</sup> wire).

The following shown a typical motion detector circuit:

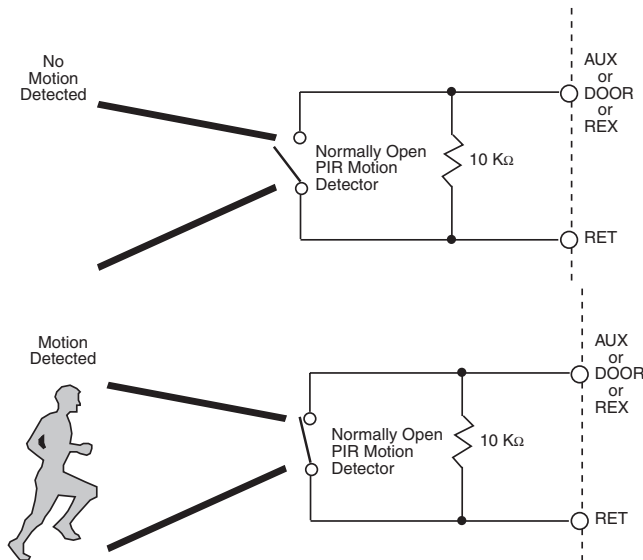

## Connecting Outputs

The AC-1 Plus module includes two Form C single-pole double-throw relay outputs. The following is a simplified schematic of each output channel:

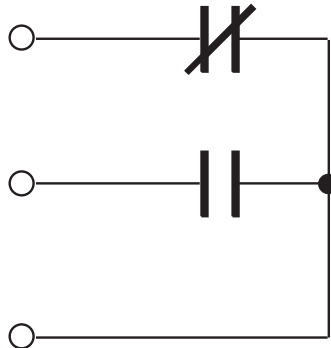

Both channels resemble the circuit shown above.

To use the Form C output in your system, configure an output point with an Electrical Type of **Digital**.

These output contacts operate as a standard relay. When the output is set to an “ON” state, the normally open contacts close and the normally closed contacts open.

**Note:** When configuring a Digital point, there is a “Polarity” attribute. If this attribute is enabled, the operation of the outputs are reversed.

## Override Controls

The AC-1 Plus module includes an output override switch for each output.

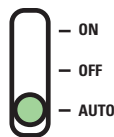

The output of the module can be directed from program control or manual control. The output can be disabled completely as well.

The following describes the actions associated with each position of the override controls:

- ON**            The output relay is energized to an “ON” state manually by setting the switch to ON. Programs have no effect on the output when the switch is in this position.
  
- OFF**            The output relay is de-energized to an “OFF” state manually by setting the switch to OFF. Programs have no effect on the output when the switch is in this position.
  
- AUTO**           The action of the output relay is determined as a direct result of program control.

## Wiring Door Outputs

The following represents a typical door output installation when the circuit is normally open:

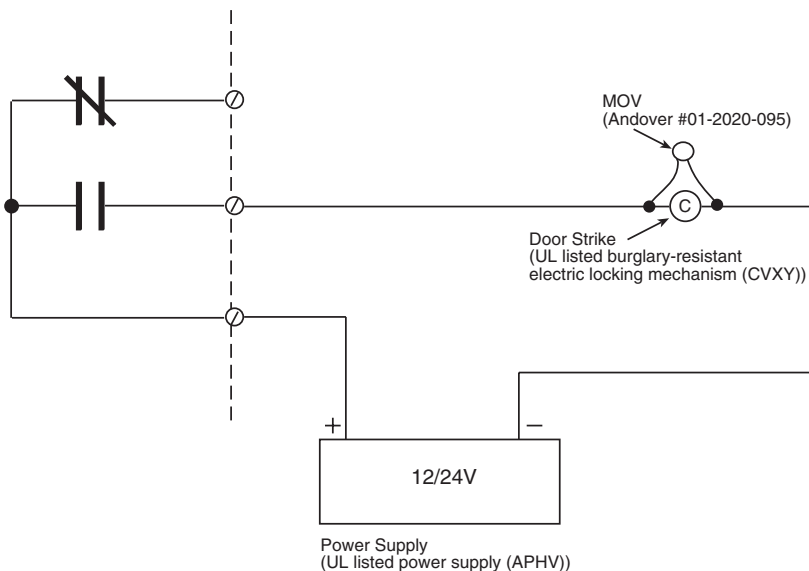

This configuration shows a normally de-energized lock (when secured) in a fail secure mode. If power loss occurs, the lock closes. Always be sure to use “panic” hardware that allows emergency exit from the secured area.



The following represents a typical door output installation when the circuit is normally closed:

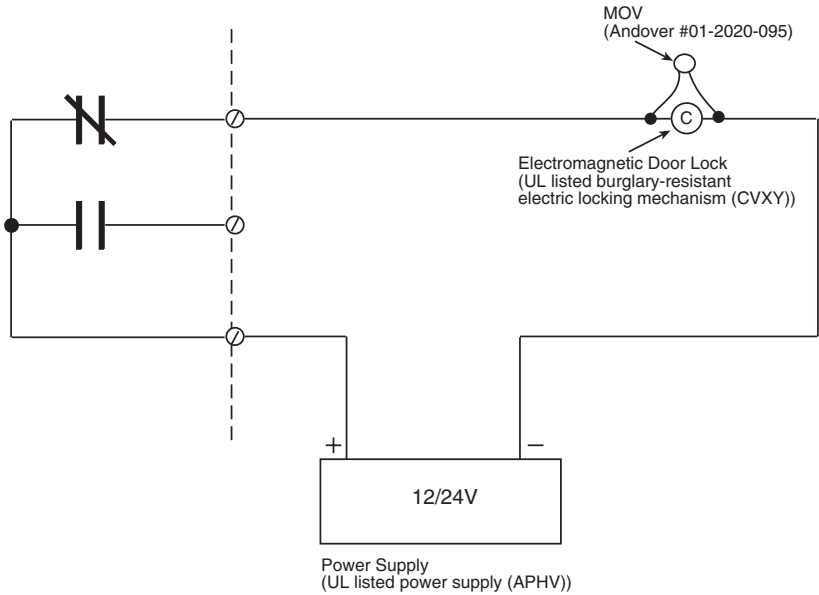

This configuration shows a normally de-energized lock (when secured) in a fail safe mode. If power loss occurs, the lock opens.

## Wiring Dual Reader Door Outputs

The following represents a typical door output installation when the dual reader door circuit is controlling a fail-safe lock:

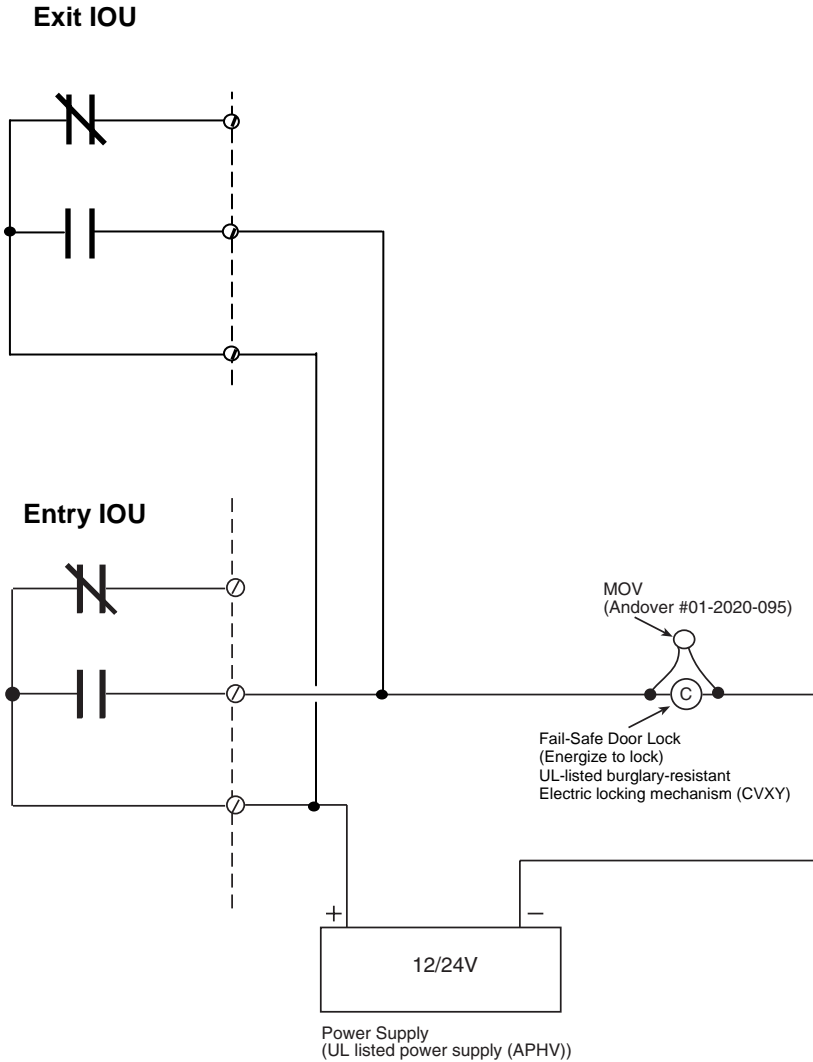

The following represents a typical door output installation when the dual reader door circuit is controlling a fail-secure lock:

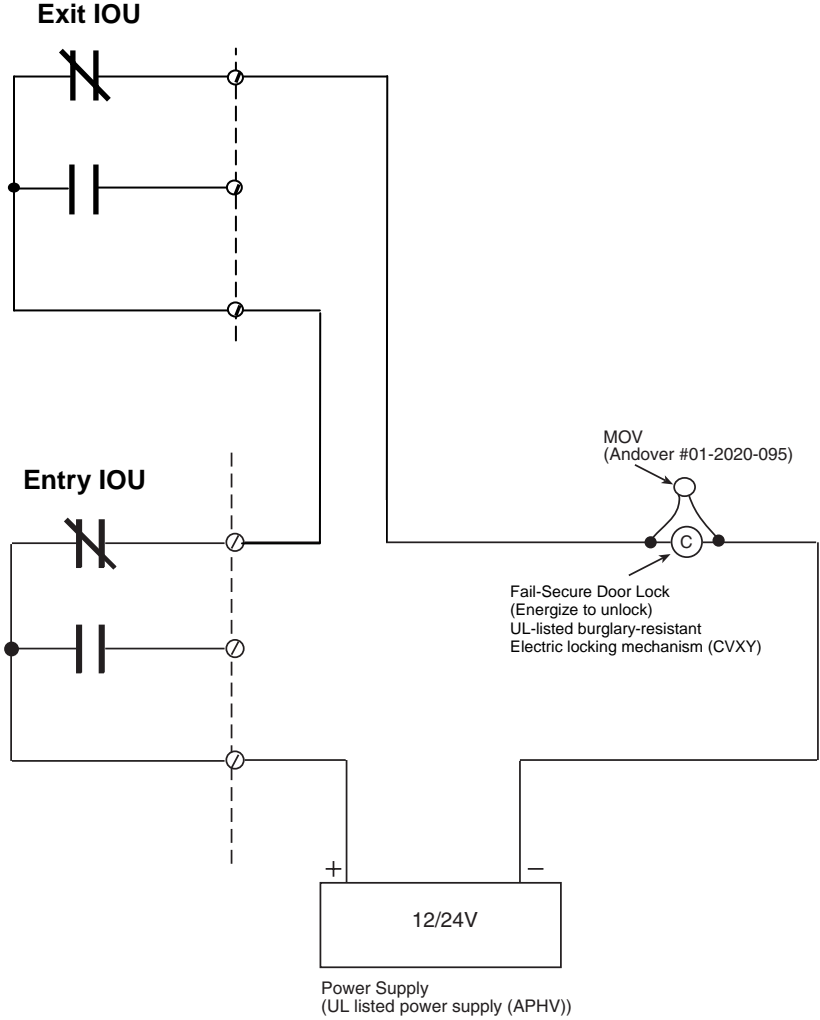

## Status/Control Panel

### Status Indicators

The AC-1 Plus module includes a complete indicator status panel on the front of the module.

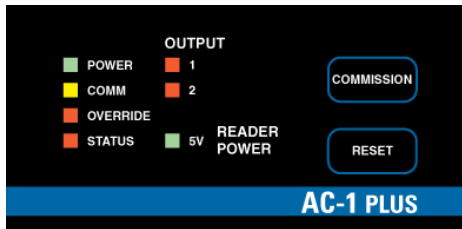

This panel includes indicators reporting on the status of the following:

- POWER** This green indicator illuminates when DC power is applied through the I/O Bus.
- COMM** This yellow indicator illuminates when data is transmitted from the module to the NetController. In normal operation, data is only transmitted when an input value changes.  
  
This indicator will also flash periodically as the NetController checks the I/O bus.
- OVERRIDE** This red indicator illuminates whenever any of the override switches is in a position other than AUTO.
- STATUS** This red indicator is normally off. If it is always on or flashing at a fast rate, there is a problem with the module.  
  
This indicator can be manually illuminated from the CyberStation workstation or Command Terminal and used as a troubleshooting aid when locating a particular module.
- OUTPUT** These red indicators (one for each channel) illuminate when an output relay is energized.
- READER POWER** This green indicator illuminates when +5VDC power is available to the reader.

This panel also includes two operator switches that perform the following:

- COMMISSION** After physical installation and during configuration through the CyberStation workstation or Command Terminal, pressing this button registers the module's address with the system. For more information, refer to the section on *Module Configuration* found earlier in this manual.
- RESET** If the module becomes inoperable, pressing this button resets the module. It does not erase its memory.

## VS-8-4, VS-8-4-T Video Switcher

The VS-8-4, Andover Continuum's video switcher module, includes eight input channels and four high-speed, buffered, output channels. Any one of the eight input lines can be connected to any of the four outputs. Each output has a gain of two and is capable of driving 75  $\Omega$ , back-terminated, lines.

The VS-8-4 is an I/O module used with the Andover Continuum Product line and can be integrated into systems requiring video security. Up to eight surveillance, cameras can be connected to the VS-8-4 inputs. The VS-8-4 video output can then be connected directly to a video monitor or other video display or recording device.

The VS-8-4-T version provides the capability of time/date stamping the video signal. In addition, a title may be added to the video signal to identify the area where the camera is being directed.

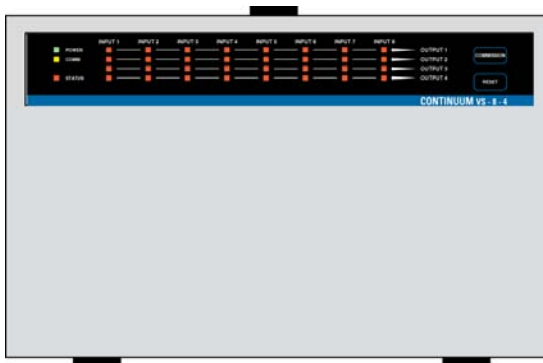

### FEATURES

- Eight (8) Video inputs
- Four (4) Video outputs
- Any one input can be connected to any of the four outputs
- 10–28 V Power Supply Range

## SPECIFICATIONS

### ELECTRICAL

<b>Power Supply Range:</b>	Input Voltage Range: 10-28V. 24V for UL294 installations.
<b>Power Consumption:</b>	2 Watts (83 mA) @ 24 VDC (max.); provided by Andover Continuum power supply module.
<b>Overload Protection:</b>	0.5 A resettable fuse with transient voltage suppressor (TVS) and reverse polarity protection.

### INPUTS

<b>Impedance:</b>	75 $\Omega$
<b>Connection:</b>	BNC connector
<b>Bandwidth (-3dB):</b>	> 75 MHz (Rload=150 $\Omega$ )
<b>Single Channel Crosstalk:</b>	> -60 dB @ 10 MHz.
<b>All Channel Crosstalk:</b>	> -50 dB @ 10 MHz.
<b>All Channel Off Isolation:</b>	> -55 dB @ 10 MHz.

### OUTPUTS

<b>Impedance:</b>	75 $\Omega$
<b>Connection:</b>	BNC connector
<b>Signal:</b>	2V pk/pk

## I/O Connections

The video input and output connections are located on the bottom of the module.

A quick disconnect spade lug connector allows for an Earth ground connection.

The diagram below indicates where each input and output is located on the module. These connections are also listed below.

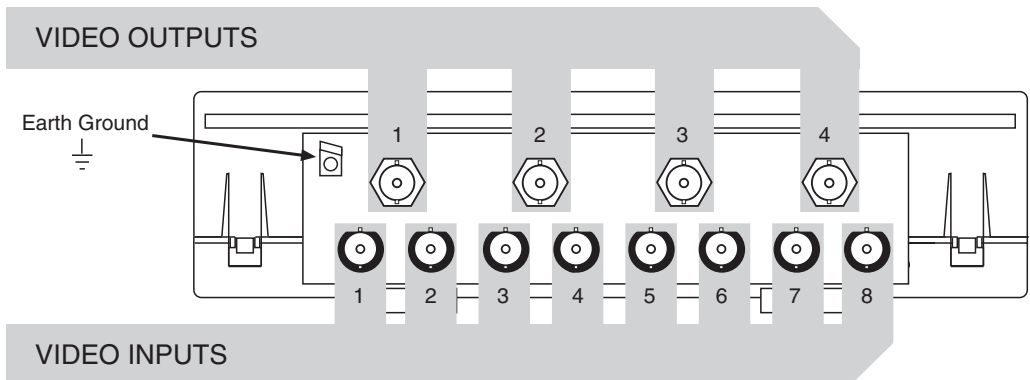

Standard BNC connections are used for each input and output.

## Programming/Use

### Video Switching

The outputs of the VS-8-4 module can have up to eight input sources. These outputs are represented as Numerics in the system. Entering a value of 1–8 selects the input source for the particular output. Values other than 1–8 turn off the video for that output. Refer to the programming table on the following page for specifics.

Configure each video output point with an Electrical Type of **Numeric**.

### Title & DateTime Programming (VS-8-4-T Only)

The VS-8-4-T version of the switch provides the capability of superimposing the time/date and a textual title over the video signal of each output. The video area is divided into twelve “lines” where this information can be displayed. Line one is at the top of the screen, line twelve is at the bottom.

The position of the date and time for all outputs is specified as a line numbered 1 though 12. Values other than 1–12 turn off the display of the datetime.

The VS-8-4-T updates the Date and Time automatically, however, it is only accurate to 1.5 seconds per hour. You can send updated datetime readings to the unit though Plain English.

Titles consist of **one line** composed up to 24 characters. Receiving more than 24 displays only the first 24 received. Text consists of white characters of 12 (horizontally) by 18 (vertical) dots (pixels). The character set supported includes all Alphanumeric (upper and lower case A–Z, 0–9) characters plus the following punctuation symbols:

,	;
-	<
.	>
/	?
:	

The display position of the title text is specified as a line numbered 1 though 12. Values other than 1–12 turn off the display of the title.

Refer to the programming table on the following page for specifics.



VS-8-4-T Configuration Programming Table

Function	Channel	Object Type	Direction	Values
Video Select Output 1	1	Numeric	IOOutput	1–8 ; corresponding to input channel number. Other values turn off this output.
Video Select Output 2	2	Numeric	IOOutput	1–8 ; corresponding to input channel number. Other values turn off this output.
Video Select Output 3	3	Numeric	IOOutput	1–8 ; corresponding to input channel number. Other values turn off this output.
Video Select Output 4	4	Numeric	IOOutput	1–8 ; corresponding to input channel number. Other values turn off this output.
Date/Time Position (All four outputs)	5	Numeric	IOOutput	1–12 ; corresponding to display line number. Other values turn off the display of datetime.
Title Position (All four outputs)	6	Numeric	IOOutput	1–12 ; corresponding to display line number. Other values turn off the display of the title.
Set Datetime	7	DateTime	IOOutput	Used to send Datetime to VS-8. See text.
Title Text Input Source 1	8	String	IOOutput	Up to 24 characters
Title Text Input Source 2	9	String	IOOutput	Up to 24 characters
Title Text Input Source 3	10	String	IOOutput	Up to 24 characters
Title Text Input Source 4	11	String	IOOutput	Up to 24 characters
Title Text Input Source 5	12	String	IOOutput	Up to 24 characters
Title Text Input Source 6	13	String	IOOutput	Up to 24 characters
Title Text Input Source 7	14	String	IOOutput	Up to 24 characters
Title Text Input Source 8	15	String	IOOutput	Up to 24 characters

## Status/Control Panel

### Status Indicators

The VS-8-4 module includes a complete indicator status panel on the front of the module.

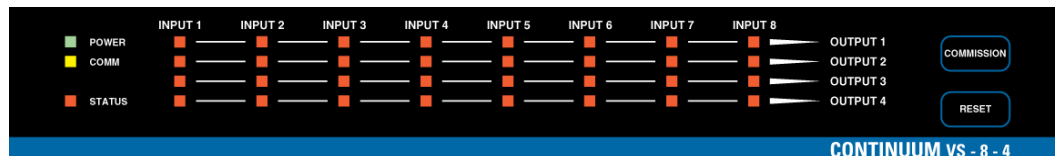

This panel includes indicators reporting on the status of the following:

- POWER** This green indicator illuminates when DC power is applied through the I/O Bus.
- COMM** This yellow indicator illuminates when data is transmitted from the module to the NetController. In normal operation, data is only transmitted when an input value changes.
- This indicator will also flash periodically as the NetController checks the I/O bus.
- STATUS** This red indicator is normally off. If it is always on or flashing at a fast rate, there is a problem with the module.
- This indicator can be manually illuminated from the CyberStation workstation or Command Terminal and used as a troubleshooting aid when locating a particular module.
- INPUTx** Each input includes four red indicators (one for each output channel). Illumination indicates a connection between input and output.

This panel also includes two operator switches that perform the following:

- COMMISSION** After physical installation and during configuration through the CyberStation workstation or Command Terminal, pressing this button registers the module's address with the system. For more information, refer to the section on *Module Configuration* found earlier in this manual.
- RESET** If the module becomes inoperable, pressing this button resets the module. It does not erase its memory.

## VT-1 Voice Telecom Module

The VT-1, *Andover Continuum's* voice-output/touch-tone input telecom module, provides users with easy-to-use remote data entry capabilities for their *Andover Continuum* system using the familiar touch-tone keypad on any standard or cellular telephone. The VT-1 provides built-in prompt messages and pre-recorded vocabulary words, which can be used individually or combined to form phrases and sentences. In addition, custom messages (up to 3 minutes total) can be pre-recorded to inform the user of building conditions and/or to prompt the user for additional input.

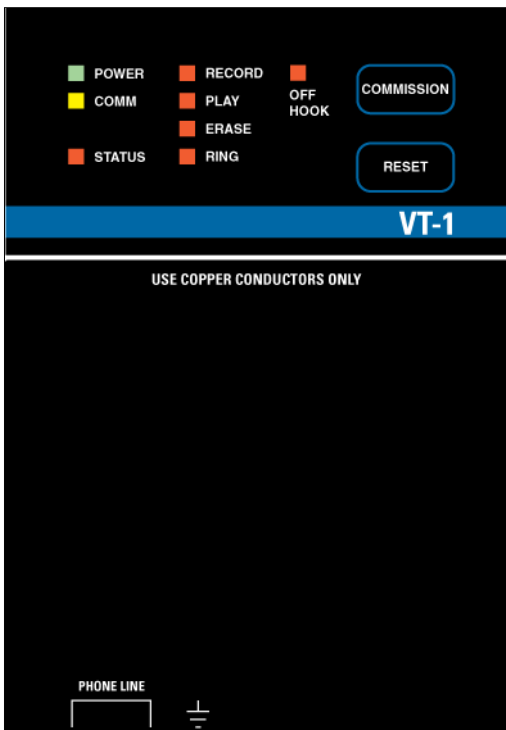

### FEATURES

- Provides a Telephone Command Interface to Andover Continuum
- Accepts DTMF menu selection
- Standard RJ-11 Telephone Interface
- Recording via Telephone
- Dial Out and Call Progress Capability

## **SPECIFICATIONS**

### **ELECTRICAL**

***Power Supply Range:***

Input Voltage Range: 20-26V.

***Power Consumption:***

1.5 Watts (63 mA) @ 24 VDC (max.); provided by Andover Continuum power supply module.

***Overload Protection:***

0.5 A resettable fuse with transient voltage suppressor (TVS) and reverse polarity protection.

### **INPUTS**

***Interface:***

Local Telephone System Interface

***Connection:***

RJ-11 connector

## Telephone Line Connection

The VT-1 connects to the local telephone line via an internal RJ-11 jack.

To install the telephone line, open the cover of the module and plug an RJ-11 cable into the jack located at the lower left as indicated below.

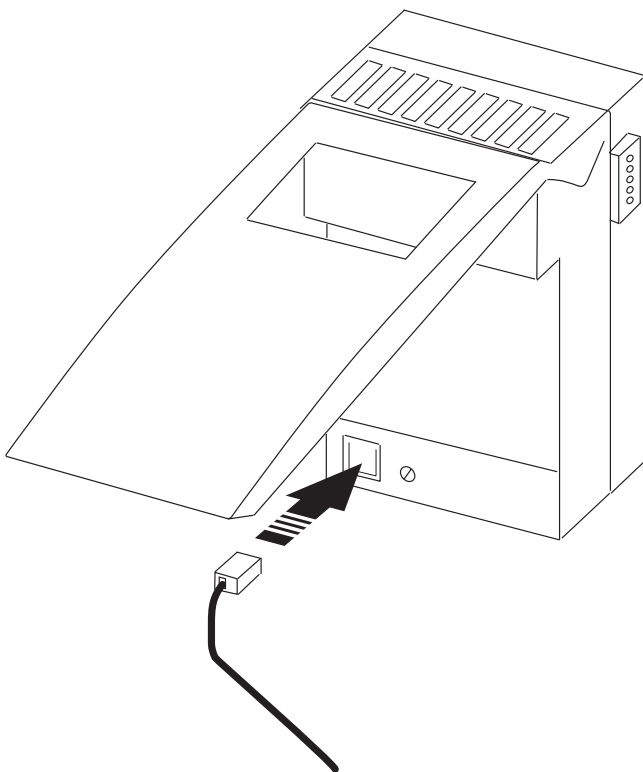

Connect the other end of the cable to a local telephone jack.

## Programming/Use

### Technical Description

The VT-1 module acts as an interface to the Andover Continuum system by allowing a user to control functions via telephone. It can be configured to operate like an auto attendant for a telephone system. As the phone line is answered, a series of voice prompts are played indicating various options that may be selected by pressing touch tone (DTMF) keys on the caller's telephone. The DTMF numbers received by the module represent a desired command or function. The module is equipped to decode the DTMF responses and send them off to an attending controller.

The module can also be commanded to dial out and provide callback numbers to a paging system.

The VT-1 operates in either of two modes:

#### *Supervisor Mode*

Supervisor Mode provides a method for recording the messages that may be played back at a later time. These messages may be application specific phrases that the controller can select for communicating with the user. It is these messages that are played to inform the caller of the various control options available.

#### *User Mode*

User mode is the normal operating mode of the VT-1. In this mode, the VT-1 is under the control of a Plain English program. When a user calls into the module, messages are played and touch-tone digits are captured.

There are three types of voice messages within the VT-1:

<b>Type of Message</b>
<p><b>SUPERVISOR PROMPT MESSAGES</b>            Not accessible by the user, strictly for            Supervisor Mode            Approximately 30 seconds</p>
<p><b>PRE-RECORDED MESSAGES</b>            Words and sentence fragments that can be            played in both User and Supervisor Mode            Approximately 80 seconds</p>
<p><b>USER RECORDED MESSAGES</b>            Custom user messages that can be recorded,            played and erased in Supervisor Mode. Available            for playback only in the User Mode.            Record Time = Approx. 190 sec ( 3 min))</p>

## Operation

The VT-1 includes several pre-recorded words and phrases. It is not necessary that you record new messages. If you intend to use these pre-recorded words, there is no need to enter Supervisor Mode.

## Security

Because the VT-1 allows connection to your system via a standard telephone line, we have included a password-based security lock to allow controlled access to its operation. Both User and Supervisor modes have their own passwords. These passwords can be changed at any time simply by editing a value stored in a Plain English numeric variable.

The system can easily monitor VT-1 activity. Whenever a user successfully logs into the VT-1 (correct password entered), a status code appears in one of the module's numeric objects.

## Supervisor Mode

The Supervisor Mode allows you to record a number of custom messages that can be selected for playback at strategic times through your program.

### ***Entering Supervisor Mode***

To enter this mode, make sure the VT-1 is connected properly to a working telephone line and is powered. From any telephone, call the number associated with the line attached to the VT-1. As the line rings the module, the VT-1 responds by answering the line (going “off-hook”). The Off Hook indicator on the front panel illuminates.

Message number 1 is played: “Enter password followed by the pound key.”

At this time you are expected to press a four-digit password followed by the pound (#) button to access the unit. The default Supervisor mode password is 1234. As indicated earlier, this password can easily be changed.

If you enter the wrong password, the VT-1 responds with Message 2: “Invalid password.” The unit then allows you to try again. In any case, if the module does not receive the correct password in 30 seconds, the VT-1 disconnects the call.

Once the correct password is received, the module plays Message 3: “Press 1 to record, 2 to play or 3 to erase a message. Press star to exit.” This is referred to as the main menu. From here you can access its supervisory functions.

***Note: In this mode, the VT-1 will automatically hang up if no DTMF activity has been received for 30 seconds.***

### ***Exiting Supervisor Mode***

To exit Supervisor mode, press the star (\*) button on your telephone when you are at the “main menu prompt”. This disconnects the VT-1 from the phone line causing the Off Hook indicator to extinguish.

Alternatively, hanging up on the module will exit the mode as well.



### **Supervisor Functions**

The messages that you can record, play and erase are stored in separate locations denoted by their “message number”. Custom messages occupy message numbers 1-150. Although there appears to be 150 possible custom messages, the limit is actually the amount of time your entire message library requires. The VT-1 allows for a total of approximately 3 minutes of custom recording time. Therefore, the total number of messages you can record cannot exceed the 3 minute limit.

When all available message space is filled, the VT-1 will not allow subsequent recording. The message: “Voice memory full” is played. To allow further recording, erase unused messages.

### **Record Message Mode (Press 1)**

Pressing the 1 button allows you to record a voice message. Message 4 plays: “Enter message number followed by the pound key. Press star to return to the main menu.”

- 1 Enter a new message number in the range **1–150**.  
Message #'s need not be consecutive. If that number has been used previously, a message: “Invalid entry” is heard. To record over an existing message, you must first erase that message.  
Enter multiple digit numbers simply by pressing them in order e.g. “125”.
- 2 Press the pound (#) button to begin recording. Begin speaking after the tone.  
**Note: Due to the internal time-out of the VT-1, an individual message cannot exceed 29 seconds.**
- 3 Once you have finished speaking the message, press any button to terminate recording. The VT-1 responds with the message: “Message recorded.”

At this point you are returned to the main menu where you can select another operation.

Pressing the star (\*) button exits the mode and returns the VT-1 to the “main menu” prompt.

**Note:** Recorded messages are stored in non-volatile memory within the VT-1 and are therefore preserved (not lost) during power outages.

***Playback Message Mode (Press 2)***

Pressing the 2 button allows you to play a recorded voice message. Message 4 plays: "Enter message number followed by the pound key. Press star to return to the main menu."

- 1 Enter a message number in the range **1–230**.  
If the message number does not contain a message, a message: "Invalid entry" is heard.  
Enter multiple digit numbers simply by pressing them in order e.g. "125".
- 2 Press the pound (#) button to begin playback.

In this mode you can play both custom user-recorded messages and the pre-recorded words and phrases stored in the VT-1. The pre-recorded words and phrases are listed along with their message numbers later in this section.

After the message finishes playing, you are returned to the main menu where you can select another operation.

Pressing the star (\*) button exits the mode and returns the VT-1 to the "main menu" prompt.

***Erase Message Mode (Press 3)***

Pressing the 3 button allows you to erase a recorded voice message. Message 4 plays: "Enter message number followed by the pound key. Press star to return to the main menu."

- 1 Enter a new message number in the range **1–150**.  
If the message number does not contain a message, a message: "Invalid entry" is heard.  
Enter multiple digit numbers simply by pressing them in order e.g. "125".
- 2 Press the pound (#) button to erase. The VT-1 responds with the message: "Message erased."

At this point you are returned to the main menu where you can select another operation.

Pressing the star (\*) button exits the mode and returns the VT-1 to the "main menu" prompt.

## **User Mode**

The User Mode is the normal operating mode of the VT-1. In this mode your Plain English program communicates to the user through the VT-1's pre-recorded voice messages and receives commands from the user via telephone button entries.

### ***Entering User Mode***

To enter this mode, make sure the VT-1 is connected properly to a working telephone line and is powered. From any telephone, call the number associated with the line attached to the VT-1. As the line rings the module, the VT-1 responds by answering the line (going "off-hook"). The Off Hook indicator on the front panel illuminates.

Message number 1 is played: "Enter password followed by the pound key."

At this time you are expected to press a four-digit password followed by the pound (#) button to access the unit. The default User mode password is 4321. As indicated earlier, this password can easily be changed.

If you enter the wrong password, the VT-1 responds with Message 2: "Invalid password." The unit then allows you to try again. In any case, if the module does not receive the correct password in 30 seconds, the VT-1 disconnects the call.

Once the correct password is received, the module sends a code to the controller through a numeric point indicating that it has been accessed by a user.

### ***Exiting User Mode***

The only way to exit this mode is for your program to stop operating in the User mode and to send the hang up command to the module. If the caller hangs up, the program should be designed to include a method of monitoring inactivity such as a timeout.

## Configuration

Your system controller communicates to the VT-1 through a series of points. The following is a table of the points that must be defined before you can use the module.

**VT-1 Configuration Programming Table**

Function	Channel	Object Type	Direction	Values
VT State	1	Numeric	I/O Input	<b>100</b> Supervisor Password Entered <b>110</b> User Password Entered <b>200</b> VT-1 Off-Hook <b>201</b> Dial Tone Present <b>202</b> Ring Signal Present <b>203</b> Busy Signal Present <b>204</b> Ringing Stopped (Phone picked up) <b>205</b> Dial Out Complete <b>300</b> Attempted to Play an Invalid Message number. <b>301</b> Message has completed playing. <b>302</b> Message is still playing.
User Response	2	String [30]	I/O Input	String of user generated DTMF responses. (max 30 char)
Supervisor Password	1	Numeric	I/O Output	<b>0-9999</b> (4 digits max)
User Password	2	Numeric	I/O Output	<b>0-9999</b> (4 digits max)
Ring Count	3	Numeric	I/O Output	<b>1-255 (Default =1)</b>
Command	4	Numeric	I/O Output	<b>8000</b> Dial Out <b>8001</b> Hang Up <b>8002</b> Single Tone Mode <b>8003</b> Multi -Tone Mode
Dial Out Phone Number	5	String [15]	I/O Output	Hayes compatible digits and pause characters (15 max)
Play Message	6	String [30]	I/O Output	Semicolon separated list of Message numbers for VT-1 concatenation. (30 character limit)

**VT State**

This Numeric input indicates the current state of the VT-1. The value contained in the numeric changes as the VT-1 operates. The various states that can be monitored are as follows:

Password Access	As the VT-1 is accessed, this numeric indicates when a successful password has been entered for either Supervisor mode ( <b>100</b> ) or User mode ( <b>110</b> ).
General Access	Whenever the VT-1 answers or originates a call, it accesses the telephone line by going “off-hook”. This action is reported by a code of <b>200</b> .
Call Out Progress	<p>The VT-1 has the capability of making a call to another telephone, paging system or other equipment. During the process of calling this outside number the status of the call is reported through a series of codes:</p> <p><b>201</b> Dial tone detected  <b>202</b> Ring tone detected  <b>203</b> Busy Signal detected  <b>204</b> Ring Signal Stop (call was answered)</p>
Dial Out Progress	The VT-1 has the ability to dial a DTMF number after it calls an outside system. This operation is typical of paging systems where you call the paging system number, wait for the prompt and then enter the phone number you want the paging party to call. When used in this mode, the VT-1 reports when it is done sending the number through the code of <b>205</b> .
Message Playback	The VT-1 reports when an invalid message number has been entered for playback (code <b>300</b> ). When a valid message is finished playing, the VT-1 reports a code of <b>301</b> . When a message is in progress, the VT-1 reports a code of <b>302</b> .

**User Response**

This String contains the values of the buttons pressed by the user in response to a prompt. In Single Tone Mode, this value would be a single character. If the caller pressed the 3-button, the String would contain the 3. In Multi-Tone Mode, the String contains all the buttons pressed. If the caller pressed 234, the String contains the series of characters 234.

**Passwords (Supervisor & User)**

These Numeric inputs contain the passwords for Supervisor and User access to the VT-1. Passwords are entered by the caller as a series of numbers, however, the password itself is represented as one number in the numeric.

For example, the default password for Supervisor mode is 1234. The caller presses four buttons to enter this series of numbers: 1-2-3-4. The numeric contains the number 1234.

If you want a three-digit password (e.g., 265), enter the number 265 into the Numeric.

The largest number you can enter into either password numeric is 65535. Passwords can be a maximum of four digits in length. If a five-digit value is entered, the most significant digit is discarded. (e.g., 65535 becomes 5535)

**Ring Count**

This Numeric determines how many rings the VT-1 will await before it answers a call. The default is 1, however you can set it to any number up to 255.

**Command**

This Numeric allows you to set the mode in which you expect user responses to occur and it allows you to hang up the line or dial out. These actions are done by entering a code into this numeric as follows:

<b>Code</b>	<b>Action</b>
8000	Dial Out
8001	Hang Up
8002	Single-Tone Mode
8003	Multi-Tone Mode

### *Command Summary*

*Single-Tone Mode* is used when you want the user to press only one digit in response to your prompt. This mode is appropriate for menu choices when you “Press 1 for something, 2 for another...”.

*Multi-Tone Mode* is used for entering values. When in this mode, the VT-1 gathers responses until the caller presses the pound (#) button. Therefore, if you are expecting the caller to enter a temperature setpoint such as 23 degrees, the caller would press 2-3-#. If you use this mode, be sure to inform your operator in your voice prompt of the need to press the pound button.

*Dial Out* is used when you want to use the VT-1 to dial an outside number in response from some user input. Entering this command causes the VT-1 to go “off-hook”, detect dial tone and dial the number contained in the Dial Out Phone Number string.

*Hang Up* terminates a dial out operation or a user operation.

### ***Dial Out Phone Number***

This String contains the phone number of the outside number you wish the VT-1 to call. Commas entered in this string indicate 2-second delays. A maximum of 15 digits can be entered in this string.

DTMF tones may be generated while off hook in the User Mode. This is intended for pager interface. To use this feature, your Plain English program, after dialing the pager phone number and receiving the Ringing Stopped value (204) in the VT State object, would enter a new phone # to this string. This new number is the desired number to be left with the pager provider. The program would then wait a predefined number of seconds and then, on a separate line label\*, would load the value of 8000 (DIAL OUT) into the Command Numeric object. The VT-1 generates the phone number and reports back a value of 205 (DIAL OUT COMPLETE) to let the program know that the phone number DTMF tones have been generated and it is now safe to hang up (go on hook). The Plain English program would then send the HANG UP command (8001).

**NOTE:** The VT-1 cannot detect the typical pager system beeps to signify the pager system is ready to accept the phone number. The user must know the time delay to wait prior to sending the DIAL OUT command after the Ringing Stopped event is received.

- *Including the number and the command numeric in a single Plain English line may cause timing problems resulting in errant numbers being sent.*

## ***Play Message***

This String contains the message number of a pre-recorded message for playing. Setting this string to a valid message number starts the VT-1 playing the desired message. When the message is finished, the VT-1 reports this fact through a code of 301 in the VT State numeric. If the message number is an invalid one, the VT-1 reports a code 300.

You can concatenate (string-together) several messages using this string. Entering message numbers separated by a semicolon (;) automatically concatenates the messages within the VT-1. This is an easy way of creating sentences from the multitude of prerecorded words and phrases found in messages 151-230.

Example:

To play the phrase “The Temperature is seventy five degrees”, the user must concatenate pre-recorded message #'s 181,175,155, and 184 respectively. This yields the following Plain English code:

VTPlaymessage = “181;175;155;184”

### ***Important Note:***

***There is a limit to the number of characters the Play Message string can handle. You must limit the number of characters to 30.***

The example message yields a total character count of 15 (one per digit).



## Pre-Recorded Voice Message List

### ***Supervisor Prompt Messages***

<b>Message Number</b>	<b>Message</b>
1	Enter password followed by the pound key.
2	Invalid password.
3	Press 1 to Record, 2 to Play or 3 to erase a message. Press * (star) to exit.
4	Enter message number followed by the pound key. Press * (star) to return to the main menu.
5	Invalid entry.
6	Message recorded.
7	Message erased.
8	Goodbye.
9	Voice Memory Full.

### ***Pre-recorded Words & Phrases***

<b>Message Number</b>	<b>Message</b>
151	One
152	Two
153	Three
154	Four
155	Five
156	Six
157	Seven
158	Eight
159	Nine
160	Ten
161	Eleven
162	Twelve
163	Thirteen
164	Fourteen
165	Fifteen
166	Sixteen
167	Seventeen
168	Eighteen
169	Nineteen
170	Twenty
171	Thirty

**Pre-recorded Words & Phrases (continued)**

<b>Message Number</b>	<b>Message</b>
172	Forty
173	Fifty
174	Sixty
175	Seventy
176	Eighty
177	Ninety
178	Hundred
179	Thousand
180	Point
181	The Temperature is
182	The Humidity is
183	Percent
184	Degrees
185	Fahrenheit
186	Celsius
187	The Set point is
188	Press 1 for yes or 2 for no.
189	Press
190	To change
191	Set point
192	Temperature
193	Humidity
194	Enter
195	Followed by the pound key
196	Alarm
197	Condition
198	Security
199	Access
200	Password
201	Invalid
202	Entry
203	Code
204	Hello
205	Please
206	Plus
207	Minus
208	Heat
209	Cool

## Status/Control Panel

### Status Indicators

The VT-1 module includes a complete indicator status panel on the front of the module.

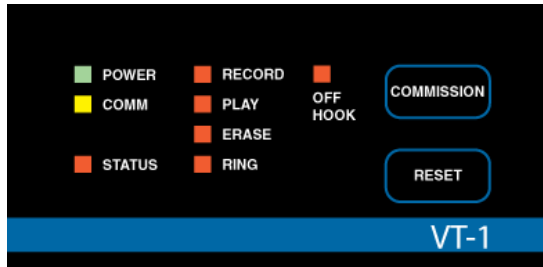

This panel includes indicators reporting on the status of the following:

- |                 |   |
|-----------------|---|
| <b>POWER</b>    | This green indicator illuminates when DC power is applied through the I/O Bus.  |
| <b>COMM</b>     | This yellow indicator illuminates when data is transmitted from the module to the NetController. In normal operation, data is only transmitted when an input value changes.<br><br>This indicator will also flash periodically as the NetController checks the I/O bus.                             |
| <b>STATUS</b>   | This red indicator is normally off. If it is always on or flashing at a fast rate, there is a problem with the module.<br><br>This indicator can be manually illuminated from the CyberStation workstation or Command Terminal and used as a troubleshooting aid when locating a particular module. |
| <b>RECORD</b>   | This red indicator illuminates when the VT-1 is recording a message.  |
| <b>PLAY</b>     | This red indicator illuminates when the VT-1 is playing a message.  |
| <b>ERASE</b>    | This red indicator illuminates when the VT-1 is erasing a message.  |
| <b>RING</b>     | This red indicator illuminates when the VT-1 is receiving a ring tone from the telephone line.  |
| <b>OFF HOOK</b> | This red indicator illuminates when the VT-1 answers the phone line or goes “off hook” to make a call.  |

This panel also includes two operator switches that perform the following:

- COMMISSION** After physical installation and during configuration through the CyberStation workstation or Command Terminal, pressing this button registers the module's address with the system. For more information, refer to the section on *Module Configuration* found earlier in this manual.
- RESET** If the module becomes inoperable, pressing this button resets the module. It does not erase its memory.



**Andover Continuum I/O System Reference**  
**Document Number 30-3001-499**  
**Rev. K**

