



# **T1K-DEVNETS**

## **DeviceNet Base Controller**

### **User Manual**

Manual Number T1K-DEVNETS-M

---



# WARNING

Thank you for purchasing automation equipment from **Automationdirect.com**<sup>™</sup>. We want your new **DirectLOGIC**<sup>™</sup> automation equipment to operate safely. Anyone who installs or uses this equipment should read this publication (and any other relevant publications) before installing or operating the equipment.

To minimize the risk of potential safety problems, you should follow all applicable local and national codes that regulate the installation and operation of your equipment. These codes vary from area to area and usually change with time. It is your responsibility to determine which codes should be followed, and to verify that the equipment, installation, and operation are in compliance with the latest revision of these codes.

At a minimum, you should follow all applicable sections of the National Fire Code, National Electrical Code, and the codes of the National Electrical Manufacturer's Association (NEMA). There may be local regulatory or government offices that can also help determine which codes and standards are necessary for safe installation and operation.

*Equipment damage or serious injury to personnel can result from the failure to follow all applicable codes and standards. We do not guarantee the products described in this publication are suitable for your particular application, nor do we assume any responsibility for your product design, installation, or operation.*

*Our products are not fault-tolerant and are not designed, manufactured or intended for use or resale as on-line control equipment in hazardous environments requiring fail-safe performance, such as in the operation of nuclear facilities, aircraft navigation or communication systems, air traffic control, direct life support machines, or weapons systems, in which the failure of the product could lead directly to death, personal injury, or severe physical or environmental damage ("High Risk Activities"). **Automationdirect.com**<sup>™</sup> specifically disclaims any expressed or implied warranty of fitness for High Risk Activities.*

For additional warranty and safety information, see the Terms and Conditions section of our Desk Reference. If you have any questions concerning the installation or operation of this equipment, or if you need additional information, please call us at 770-844-4200.

This publication is based on information that was available at the time it was printed. At **Automationdirect.com**<sup>™</sup> we constantly strive to improve our products and services, so we reserve the right to make changes to the products and/or publications at any time without notice and without any obligation. This publication may also discuss features that may not be available in certain revisions of the product.



## Trademarks

This publication may contain references to products produced and/or offered by other companies. The product and company names may be trademarked and are the sole property of their respective owners. **Automationdirect.com**<sup>™</sup> disclaims any proprietary interest in the marks and names of others.

**Copyright 2001, Automationdirect.com**<sup>™</sup> Incorporated  
**All Rights Reserved**

No part of this manual shall be copied, reproduced, or transmitted in any way without the prior, written consent of **Automationdirect.com**<sup>™</sup> Incorporated. **Automationdirect.com**<sup>™</sup> retains the exclusive rights to all information included in this document.



# AVERTISSEMENT



Nous vous remercions d'avoir acheté l'équipement d'automatisation de **Automationdirect.com™**. Nous tenons à ce que votre nouvel équipement d'automatisation **DirectLOGIC™** fonctionne en toute sécurité. Toute personne qui installe ou utilise cet équipement doit lire la présente publication (et toutes les autres publications pertinentes) avant de l'installer ou de l'utiliser.

Afin de réduire au minimum le risque d'éventuels problèmes de sécurité, vous devez respecter tous les codes locaux et nationaux applicables régissant l'installation et le fonctionnement de votre équipement. Ces codes diffèrent d'une région à l'autre et, habituellement, évoluent au fil du temps. Il vous incombe de déterminer les codes à respecter et de vous assurer que l'équipement, l'installation et le fonctionnement sont conformes aux exigences de la version la plus récente de ces codes.

Vous devez, à tout le moins, respecter toutes les sections applicables du Code national de prévention des incendies, du Code national de l'électricité et des codes de la National Electrical Manufacturer's Association (NEMA). Des organismes de réglementation ou des services gouvernementaux locaux peuvent également vous aider à déterminer les codes ainsi que les normes à respecter pour assurer une installation et un fonctionnement sûrs.

L'omission de respecter la totalité des codes et des normes applicables peut entraîner des dommages à l'équipement ou causer de graves blessures au personnel. Nous ne garantissons pas que les produits décrits dans cette publication conviennent à votre application particulière et nous n'assumons aucune responsabilité à l'égard de la conception, de l'installation ou du fonctionnement de votre produit.

Nos produits ne sont pas insensibles aux défaillances et ne sont ni conçus ni fabriqués pour l'utilisation ou la revente en tant qu'équipement de commande en ligne dans des environnements dangereux nécessitant une sécurité absolue, par exemple, l'exploitation d'installations nucléaires, les systèmes de navigation aérienne ou de communication, le contrôle de la circulation aérienne, les équipements de survie ou les systèmes d'armes, pour lesquels la défaillance du produit peut provoquer la mort, des blessures corporelles ou de graves dommages matériels ou environnementaux ("activités à risque élevé"). La société **Automationdirect.com™** nie toute garantie expresse ou implicite d'aptitude à l'emploi en ce qui a trait aux activités à risque élevé.

Pour des renseignements additionnels touchant la garantie et la sécurité, veuillez consulter la section Modalités et conditions de notre documentation. Si vous avez des questions au sujet de l'installation ou du fonctionnement de cet équipement, ou encore si vous avez besoin de renseignements supplémentaires, n'hésitez pas à nous téléphoner au 770-844-4200.

Cette publication s'appuie sur l'information qui était disponible au moment de l'impression. À la société **Automationdirect.com™**, nous nous efforçons constamment d'améliorer nos produits et services. C'est pourquoi nous nous réservons le droit d'apporter des modifications aux produits ou aux publications en tout temps, sans préavis ni quelque obligation que ce soit. La présente publication peut aussi porter sur des caractéristiques susceptibles de ne pas être offertes dans certaines versions révisées du produit.

## Marques de commerce

La présente publication peut contenir des références à des produits fabriqués ou offerts par d'autres entreprises. Les désignations des produits et des entreprises peuvent être des marques de commerce et appartiennent exclusivement à leurs propriétaires respectifs. **Automationdirect.com™** nie tout intérêt dans les autres marques et désignations.

Copyright 2001, **Automationdirect.com™** Incorporated

Tous droits réservés

Nulle partie de ce manuel ne doit être copiée, reproduite ou transmise de quelque façon que ce soit sans le consentement préalable écrit de la société **Automationdirect.com™** Incorporated. **Automationdirect.com™** conserve les droits exclusifs à l'égard de tous les renseignements contenus dans le présent document.

# Manual Revisions

---



*If you contact us in reference to this manual, be sure to include the revision number.*

**Title:** Terminator I/O DeviceNet Base Controller User Manual

**Manual Number:** T1K-DEVNETS-M

Edition	Date	Description of Changes
Original	11/01	Original issue



# Table of Contents

---

## Chapter 1: Getting Started

<b>Introduction</b> .....	<b>1-2</b>
The Purpose of this Manual .....	1-2
Supplemental Manuals .....	1-2
Who Should Read this Manual .....	1-2
Technical Support .....	1-2
Symbols Used .....	1-3
<b>Introduction to DeviceNet</b> .....	<b>1-4</b>
DeviceNet Concepts .....	1-4
The ODVA .....	1-4
<b>Terminator I/O System</b> .....	<b>1-5</b>
Mini Glossary .....	1-5
<b>T1K-DEVNETS Base Controller</b> .....	<b>1-6</b>
T1K-DEVNETS Base Controller Features .....	1-6

## Chapter 2: Installing the T1K-DEVNETS Base Controller

<b>Installing the T1K-DEVNETS</b> .....	<b>2-2</b>
Mounting on DIN Rail .....	2-2
Connecting the Controller to a Power Supply .....	2-2
Setting the Node Address .....	2-3
Connecting the Components on the DIN Rail .....	2-3
Removing I/O Modules from the Base .....	2-4
Assembling the I/O Modules and Bases .....	2-4
DIP Switch Settings .....	2-5
Parameter initialization values .....	2-6
T1K-DEVNETS setup parameters .....	2-6
Wiring the Controller to a DeviceNet Network .....	2-7
Serial Port (RS-232) .....	2-7
<b>Configuring the Controller</b> .....	<b>2-8</b>
Configuring the DeviceNet Base Controller .....	2-8
Status Indicators .....	2-9
Outputs Switch .....	2-9
<b>Master/Slave Communications</b> .....	<b>2-10</b>
<b>Terminator I/O Backplane Communications</b> .....	<b>2-11</b>
I/O Module Memory Map .....	2-11

## Appendix A: Specification

<b>Specifications</b> .....	<b>A-2</b>
-----------------------------	------------

## Appendix B: Tables

<b>Data Input and Output Tables</b> .....	<b>B-2</b>
Input Register Object Class (107) .....	B-2
Output Register Object Class (108) .....	B-4
Data Register Range .....	B-5
<b>I/O Diagnostic Information</b> .....	<b>B-6</b>
DIP Switch SW4 .....	B-6
System Information Object Specifications .....	B-7

## Appendix C: Image Table Mapping

Image Table Mapping .....	C-2
---------------------------	-----

## Appendix D: T1K-DEVNETS Think & Do Setup

T1K-DEVNETS Think & Do Setup .....	D-2
T & D Studio setup for PC control .....	D-2

## Appendix E: T1K-DEVNETS and RSNetWorx™ Setup

Setup T1K-DEVNETS with RSNetWorx™ .....	E-2
RSLinx .....	E-2
RSLogix .....	E-6
Configure T1K-DEVNETS with RSNetWorx™ .....	E-8
Using the EDS file .....	E-8
Go on line .....	E-11
Set up I/O parameters .....	E-12
Map the nodes .....	E-15
Set Class Instance Attribute .....	E-18

# Getting Started

---

## In This Chapter. . . .

- Introduction
  - Introduction to DeviceNet
  - Terminator I/O System
  - T1K-DEVNETS DeviceNet Base Controller
-

## Introduction

### The Purpose of this Manual

This manual describes the installation and operation of the Terminator I/O DeviceNet Base Controller (T1K-DEVNETS).

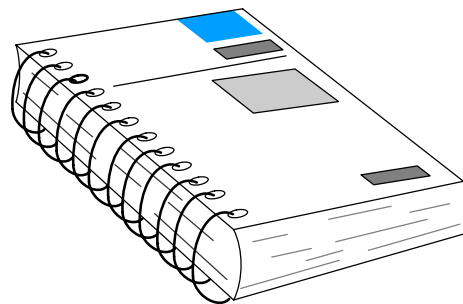

### Supplemental Manuals

The following manuals are essential to the proper use of your Terminator I/O DeviceNet Adapter.

- *Terminator Installation and I/O Manual* part number **T1K-INST-M**  
This manual contains very important information, including a complete I/O Module Memory Map. The Memory Map is crucial in designing and implementing a Terminator I/O system.
- The PLC/PC software manual
- The DeviceNet software (if separate) manual
- The DeviceNet Scanner (or Master) manual

### Who Should Read this Manual

If you have a working knowledge of the DeviceNet network, the DeviceNet software and PLC or PC which you are using, this manual will help you configure and install your T1K-DEVNETS DeviceNet Base Controller.

### Technical Support

We strive to make our manuals the best in the industry and rely on your feedback in reaching our goal. If you cannot find the solution to your particular application, or, if for any reason you need additional technical assistance, please call us at

**770-844-4200.**

Our technical support team is glad to work with you in answering your questions. They are available **weekdays from 9:00 a.m. to 6:00 p.m. Eastern Time**. We also encourage you to visit our website where you can find technical and nontechnical information about our products and our company.

**[www.automationdirect.com](http://www.automationdirect.com)**



## Symbols Used

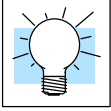

---

The “light bulb” icon in the left-hand margin indicates a **tip** or **shortcut**.

---



---

The “note pad” icon in the left-hand margin indicates a **special note**.

---

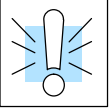

---

The “exclamation mark” icon in the left-hand margin indicates a **warning** or **caution**. These are very important because the information may help you prevent serious personal injury or equipment damage.

---

## Key Topics for Each Chapter

The beginning of each chapter will list the key topics that can be found in that chapter.

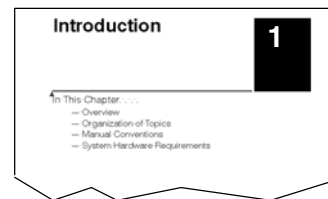

## Introduction to DeviceNet

DeviceNet is a low-level network designed to connect factory-floor devices to control systems. There are a host of manufacturers of DeviceNet products, offering an array of products including sensors, motor drives and starters, PLCs, pushbuttons, remote I/O systems, etc.

### DeviceNet Concepts

Here are some DeviceNet concepts you may find helpful.

- DeviceNet supports various communication structures including Peer to Peer, Multi-master and Master/Slave. *The T1K-DEVNETS uses the predefined Master/Slave connection.*
- DeviceNet has two types of messaging: Explicit Messaging and I/O Messaging.
  - Explicit Messaging is low priority, not time-critical and usually for configuration/diagnostic purposes.
  - I/O Messaging is time-critical and high priority for I/O data transfer. I/O Messaging comes in four types:
    - Strobed
    - Polled (*The T1K-DEVNETS only supports Polled.*)
    - Change of State (or COS)
    - Cyclic
- A single DeviceNet network is limited to 64 nodes. A node can be a single-bit device, such as a limit switch, or a remote I/O slave with several I/O modules, such as the T1K-DEVNETS. The Master (Scanner) is usually assigned to node address 0, and many Slave devices have a factory default node address of 63.
- DeviceNet has the following data rates (with maximum bus lengths):
  - 125 kbps (bus length = 500m max.)
  - 250 kbps (bus length = 250m max.)
  - 500 kbps (bus length = 100m max.)
- The 24V DeviceNet power supply must be grounded at only one point. The V- terminal must be tied to Protective Earth Ground at the power supply only.

### The ODVA

The DeviceNet standard is maintained by the ODVA (Open DeviceNet Vendor Association, Inc.). Contact the ODVA for detailed information about DeviceNet.

Open DeviceNet Vendor Association, Inc.

20423 State Road 7

Suite 499

Boca Raton, FL 33498

Phone: (954) 340-5412

Fax: (954) 340-5413

**Internet:** [www.odva.org](http://www.odva.org)

Email: [odva@powerinternet.com](mailto:odva@powerinternet.com)

# Terminator I/O System

Terminator I/O is a modular system which combines the functions of terminal blocks and I/O modules for distributed I/O. Each Terminator I/O system has the following components: a Power Supply, a Base Controller, and one or more I/O Module(s).

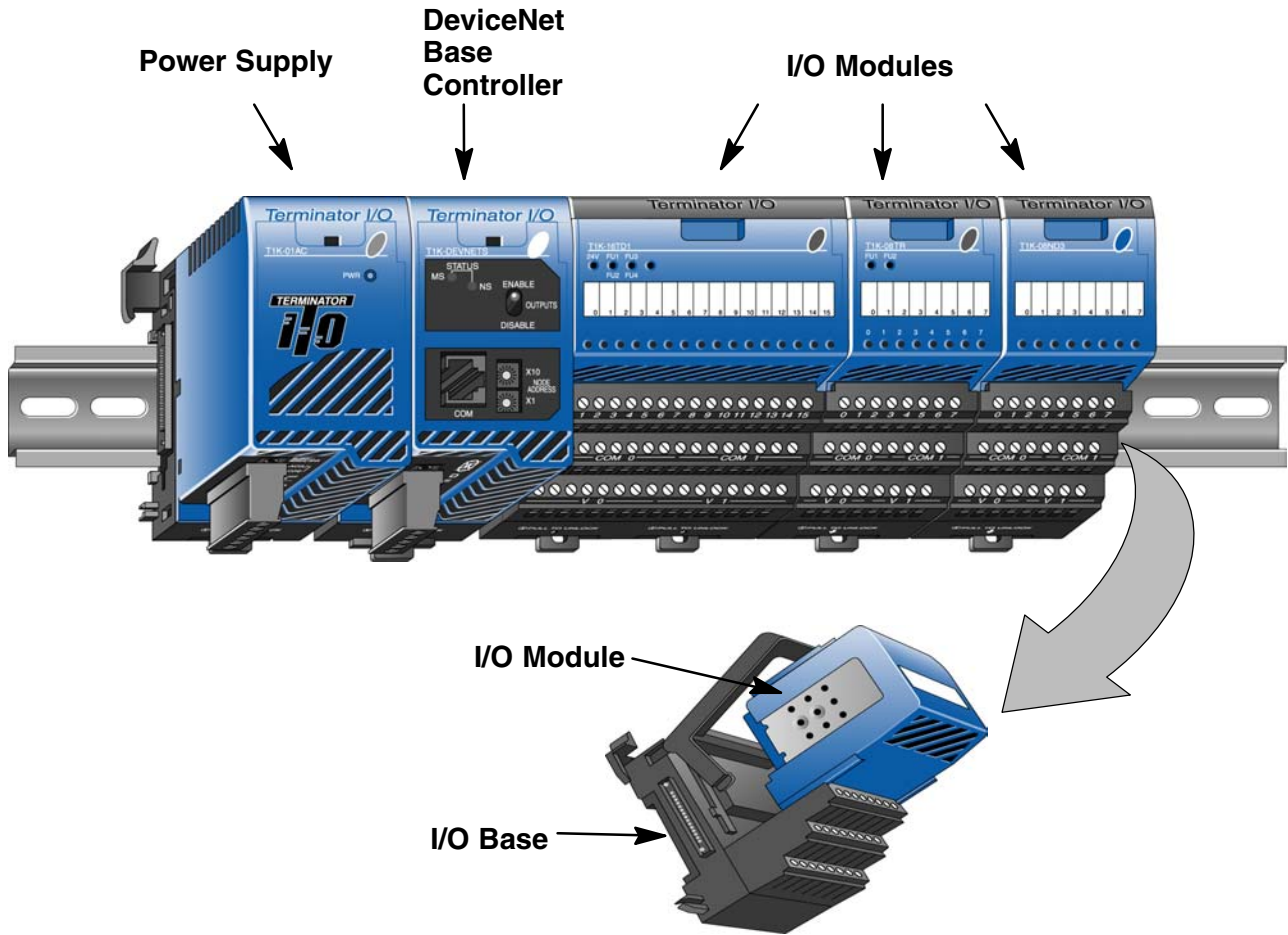

## Mini Glossary

Below is a small glossary of terms used in this manual.

**Scanner or Master**

The DeviceNet Master of which the T1K-DEVNETS is a slave. This can be either a PLC module or a card in your PC.

**Controller or Slave**

Short for the T1K-DEVNETS Base Controller. The controller is also referred to as a Network Interface Module elsewhere.

**Node Address or MAC ID**

The unique device address on a DeviceNet network. There are a maximum of 64 total (0-63). Usually the scanner is node 0.

## T1K-DEVNETS Base Controller

The T1K-DEVNETS Base Controller is a slave module that functions as a controller for Terminator I/O on a DeviceNet network.

### T1K-DEVNETS Base Controller Features

The Controller has the following features:

- Status LEDs (Module and Network)
- Serial Port
- Node Address Switches
- Output Enable Switch
- DeviceNet Connector

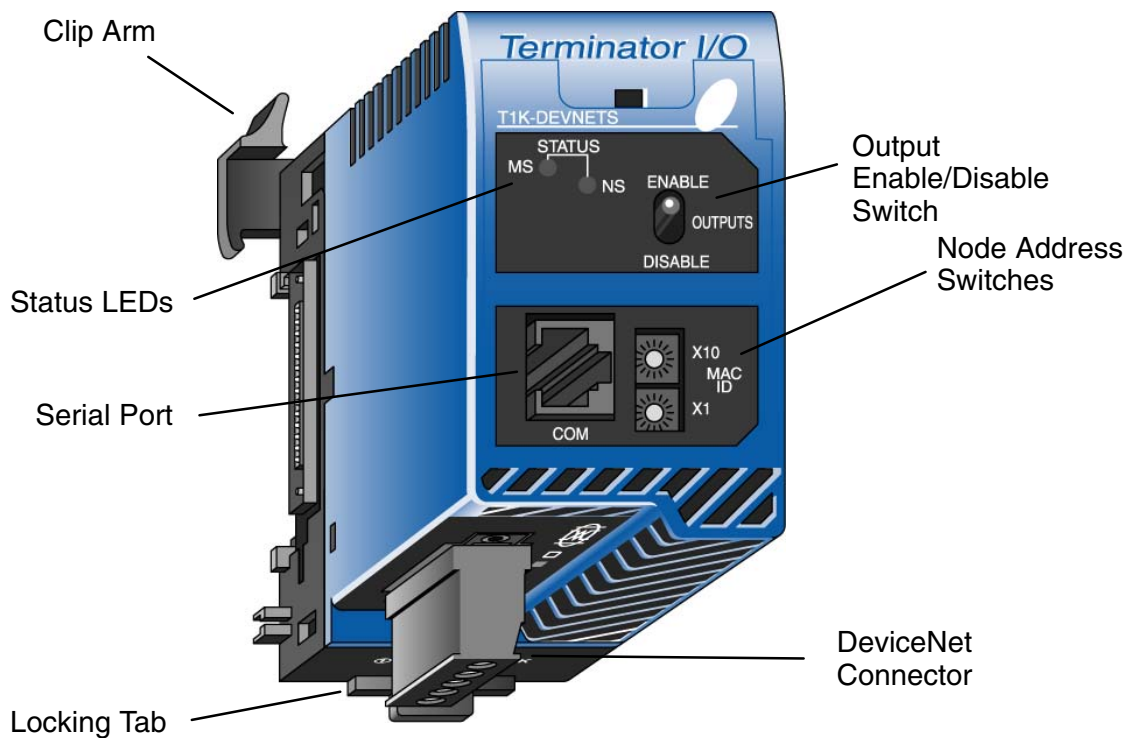

# Installing the T1K–DEVNETS Base Controller

---

## In This Chapter. . . .

- Installing the T1K–DEVNETS Base Controller
  - Configuring the Controller
  - Master/Slave Communications
  - Terminator I/O Backplane Communications
-

## Installing the T1K-DEVNETS

### Mounting on DIN Rail

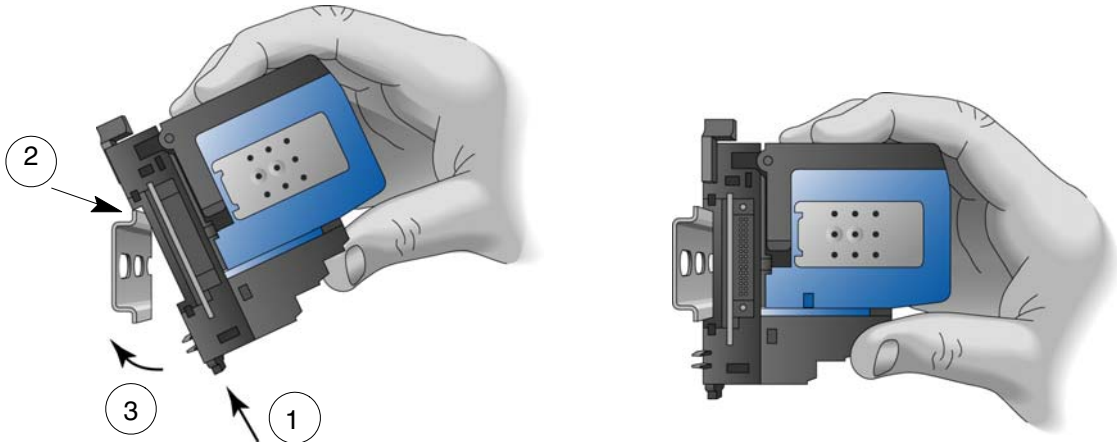

**NOTE:** Do not force the base controller onto the DIN rail. Due to slight size variations in different manufacturer's DIN rail, it may be necessary to first unlatch the locking tab, rotate the module into place, then latch the locking tab.

1. Make sure the locking tab is in the latched position (pushed in).
2. Hook upper tab over upper flange of DIN rail.
3. Tilt the unit toward DIN rail until it snaps securely to DIN rail.

### Connecting the Controller to a Power Supply

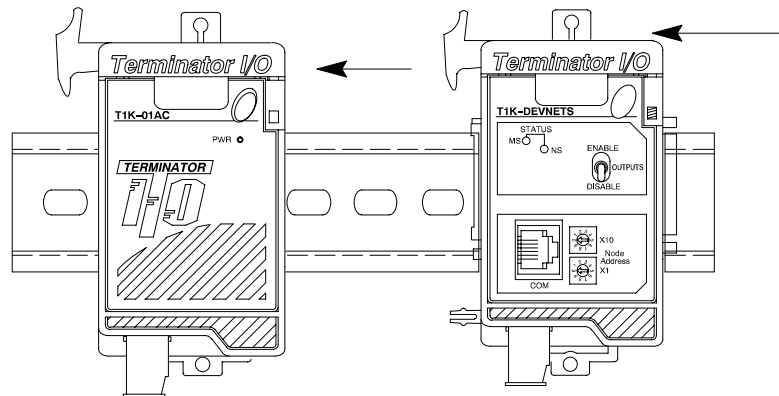

Slide the controller onto the DIN rail until the clip arm attaches securely to the power supply.

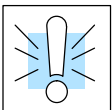

**WARNING:** Power to the T1K Power Supply **must** be disconnected before installing or removing the T1K-DEVNETS. Failure to disconnect power could result in serious damage to the module, to the power supply or both.

## Setting the Node Address

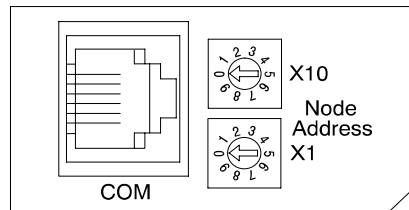

Use a small flat screwdriver to set the Node Address to an *available* Node Address (or MAC ID), from 0 – 63. Note that X10 represents the tens place and X1 represents the units place.

## Connecting the Components on the DIN Rail

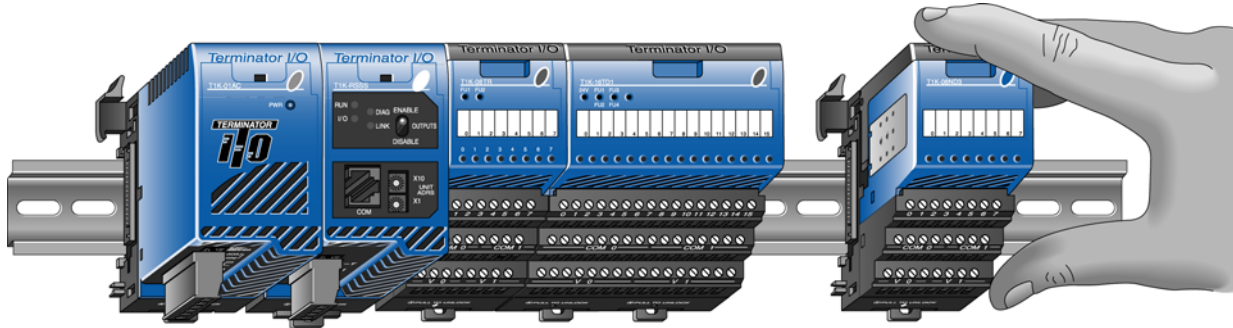

Slide the module assembly onto the DIN rail until the clip arm attaches securely to the adjacent module.



**WARNING:** Again, be sure that the power to the T1K Power Supply is **disconnected** before installing or removing the module assembly. Failure to disconnect power could result in serious damage to the modules, to the power supply or to the entire assembly.

### Removing I/O Modules from the Base

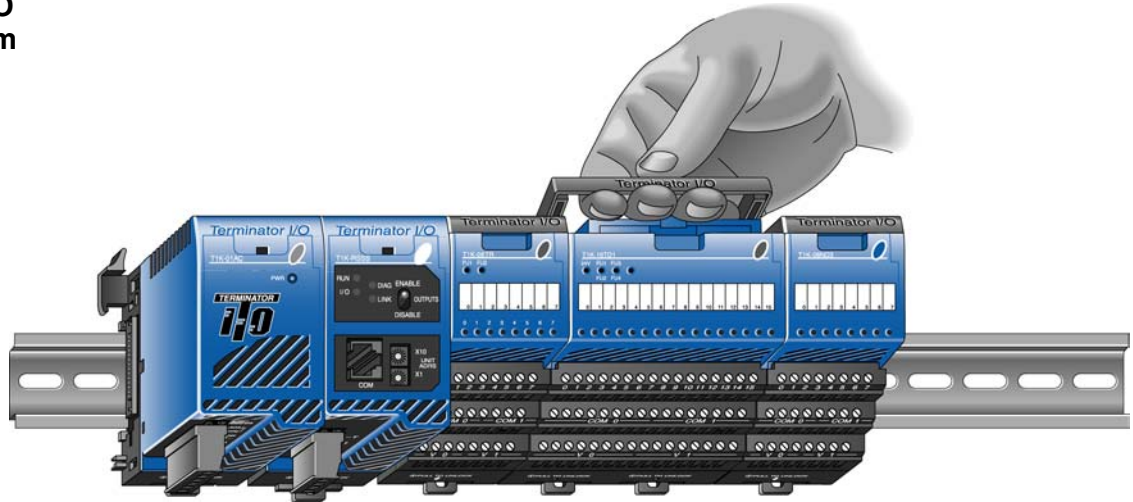

To remove the module from the base, grip the center of the base arm and rotate outward releasing the module.

To remove the module assembly from the DIN rail, lift the clip arm up and slide the module assembly away from the adjacent module. Pull the locking tab down (out) and lift the assembly off the DIN rail. Refer to the “I/O Module Hot Swap Feature”, page 3-17, in the *Terminator I/O Installation and I/O Manual (T1K-INST-M)*, to remove an I/O module with Terminator I/O system power ON.

### Assembling the I/O Modules and Bases

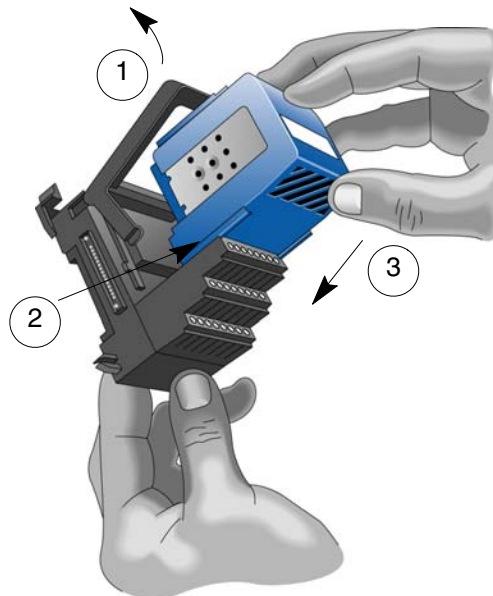

#### Insert Module into Base

1. Pull base arm back to allow space for module to enter base
2. Align module slides with base track
3. Press module firmly into base



**DIP Switch Settings**

The T1K-DEVNETS controller has a DIP Switch which is used to set baud rates, initializing and the state of outputs if a communication error occurs. The DIP Switch is located on the side of the unit, opposite the power supply.



**Note:** Be sure to look closely at the default settings below. If you are connecting to an existing DeviceNet network, you may need to change the DeviceNet Baud Rate on your T1K-DEVNETS. *The factory default baud rate is 125kbps.*

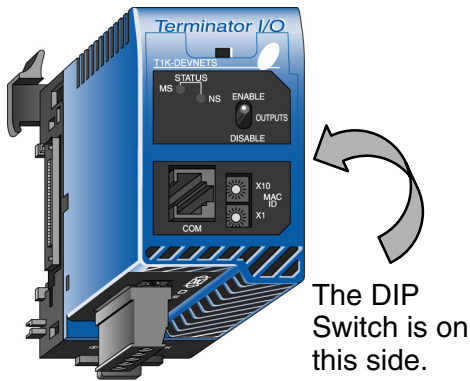

DIP SW		
OFF	ON	
<input type="checkbox"/>	<input type="checkbox"/>	SW1
<input type="checkbox"/>	<input type="checkbox"/>	SW2
<input type="checkbox"/>	<input type="checkbox"/>	SW3
<input type="checkbox"/>	<input type="checkbox"/>	SW4
<input type="checkbox"/>	<input type="checkbox"/>	SW5
<input type="checkbox"/>	<input type="checkbox"/>	SW6
<input type="checkbox"/>	<input type="checkbox"/>	SW7
<input type="checkbox"/>	<input type="checkbox"/>	SW8

DeviceNet Baud Rate (SW1, SW2)  
 16/32 Bit/Channel Analog Selection (SW3)  
 I/O Polling Diagnostics Enable/Disable (SW4)  
 Hold Outputs (on Comm. Error) (SW5)  
 Maintenance Port Baud Rate (SW6)  
 Maintenance Port Protocol Selection (SW7)  
 Maintenance Port RTS/CTS Control Enable/Disable (SW8)

**Factory Default Settings Shown (all OFF)**

**Set the DeviceNet baud rate.**

DeviceNet Baud Rate		
Baud Rate	SW1	SW2
125 kbps	OFF	OFF
250 kbps	ON	OFF
500 kbps	OFF	ON
Reserved	ON	ON

Analog Bit Selection		
No. of Bits	SW3	Description
32	OFF	Defaults to original 2-word (32 bits) per analog channel.
16	ON	N/A

**Parameter Table**

System V-Memory	Description	SW3=OFF	SW3=ON	Comment
V7614	Input register: Starting location	V3000	V3000	Read only
V7615	Input Register: Number of bytes	58 Bytes	128 Bytes	Read only
V7616	Output Register: Starting location	V3100	V3100	Read only
V7617	Output Register: Number of bytes	52 Bytes	128 Bytes	Read only

Disable I/O Polling Diagnostics *	
I/O Diagnostics	SW 4
Enable	OFF
Disable	ON

\* If DIP Switch 4 is in the OFF (default) position, you must allow for two additional bytes on the input (RX) and two additional bytes on the output (TX) for Terminator I/O diagnostic functions. Refer to page B-6 for the I/O diagnostic information.

Hold Outputs		Maintenance Port Baud Rate		Maintenance Port Protocol Selection	
Outputs	SW5	Baud Rate	SW 6	Protocol	SW7
Turn Off	OFF	9600 bps	OFF	Normal	OFF
Hold	ON	19200 bps	ON	ASCII	ON

Maintenance Port RTS/CTS Control		
SW 8	RTS/CTS	Description
OFF	Disable	RTS/CTS not available
ON	Enable	RTS/CTS available

### T1K-DEVNETS setup parameters

Setting up the parameters of the T1K-DEVNETS will set the values to special registers when power is applied to it. When the registers are set to the correct range, their parameters will be stored in EEPROM, and the parameters will be retained when power is turned off. Refer to the following table.

**Parameter Table**

System V-Memory	Description	Value when the scratch pad is initialized	Range
V7614	Input register: Starting location	V3000	V0 - V7377
V7615	Input Register: Number of bytes	58 Bytes	0 - 128
V7616	Output Register: Starting location	V3100	V0 - V7377
V7617	Output Register: Number of bytes	52 Bytes	0 - 128

**Wiring the Controller to a DeviceNet Network**

Connect the DeviceNet cable (Belden 3085A, YR-29832 or equivalent) to the removable connector as shown below. The wire colors are also labeled on the Controller front. Be sure to connect a terminating resistor (121 Ohm 1%, 1/4W).

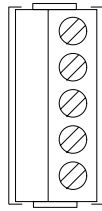

- V- (black)
- CAN\* Low (blue)
- Shield (bare)
- CAN\* High (white)
- V+ (red)



Connect a terminating resistor across the CAN High (white) and CAN Low (blue) screw terminals.

*The terminating resistor is 121 Ohm 1%, 1/4 Watt. (2 resistors are included with each T1K-DEVNETS).*

\* Controller Area Network (CAN)

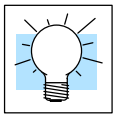

**Tip:** Be sure that each end of the DeviceNet network 'trunk' has a proper terminating resistor connected as shown above.

**Serial Port (RS-232)**

The T1K-DEVNETS serial port is used to update the firmware of the base controller when necessary. Use cable part number **D2-DSCBL** to connect the T1K-DEVNETS to a PC, or use the following information to make a cable.

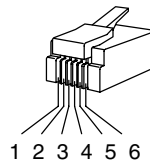
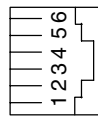

Serial Port Pinout	
Pin	Signal
1	0V
2	+5V
3	RXD
4	TXD
5	RTS
6	CTS

## Configuring the Controller

### Configuring the DeviceNet Base Controller

Use the software of your DeviceNet master to configure the controller for your network. *Refer to the software Help file and/or manual for help with configuration.* Follow these basic steps when configuring your T1K-DEVNETS controller.

- 1. Set the Controller Node Address:**  
In the DeviceNet master software, make sure the Controller node address is set to an available node number on the DeviceNet network (from 0 to 63).
- 2. Add the EDS file (if required by the software):**  
In your DeviceNet software, add the T1K-DEVNETS Electronic Data Sheet (EDS) file from the disk which came with this manual or from our web site [www.automationdirect.com](http://www.automationdirect.com). Some software may not provide for the use of EDS files.
- 3. Commission the Node:**  
Use the DeviceNet software to “Commission the Node” of your Controller. Again, some software may not require this.
- 4. Add the T1K-DEVNETS to the Scan List:**  
Add the T1K-DEVNETS to the Scan List in your DeviceNet Master software.
- 5. Set the Input/Output Bytes:**  
If required by your DeviceNet software, set the I/O Parameters to Tx = Output bytes and Rx = Input bytes (on the Scanner’s Scan List tab), for Polled I/O. *Either use the tables located in the appendixes or go to page E-18 and follow the steps in the example.*
- 6. Map the I/O to the Master:**  
Map the T1K-DEVNETS I/O to the Scanner using Auto Map, or map the I/O to another location if desired.
- 7. Scan:**  
Go Online (or Scan) to verify the configuration and check for errors.
- 8. View Indicators on the Controller:**  
Refer to the Status Indicators when connecting to the network.

**Status Indicators**

The Controller has two Status Indicators, one for Module Status and the other for Network Status.

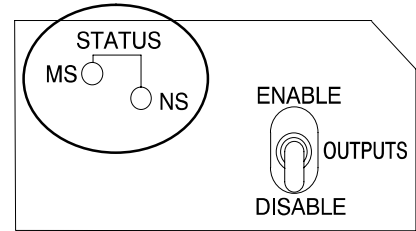

MS (Module Status) Indicator	
Indication	Status
OFF	No power to Controller. Check wiring.
ON (Green)	Power applied to Controller, no fault
ON (Red)	Critical Controller Fault
NS (Network Status) Indicator	
Indication	Status
OFF	No power to Controller or no Network Access
Flashing Green	Online but not connected
Solid Green	Online, link okay and connected
Flashing Red	Recoverable fault
Solid Red	Critical Controller Fault (Duplicate ID or Bus off)

Installing the DeviceNet Base Controller

**Outputs Switch**

The Outputs switch enables or disables outputs connected to the Controller.

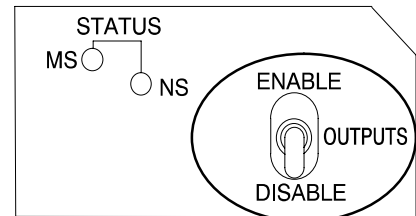

**Note:** It is good safe practice to disable outputs before Hot Swapping modules if the application allows this.

## Master/Slave Communications

The T1K-DEVNETS controller (slave) communicates with the DeviceNet scanner (master) by sending Input Data and receiving Output Data. The controller *reads* Inputs from I/O Modules and *writes* Outputs to I/O Modules.

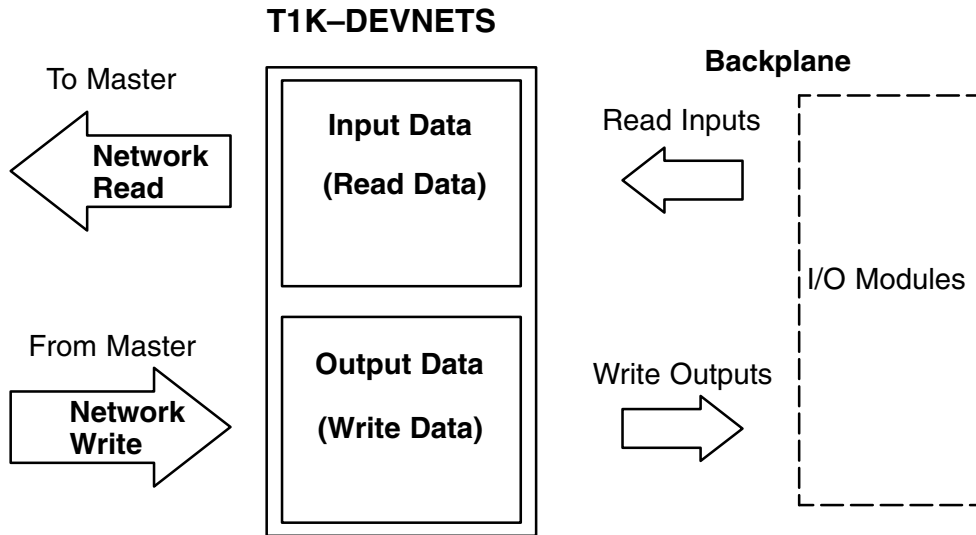

## Terminator I/O Backplane Communications

The Controller communicates with its I/O modules over the backplane. The I/O is mapped in consecutive order as shown.

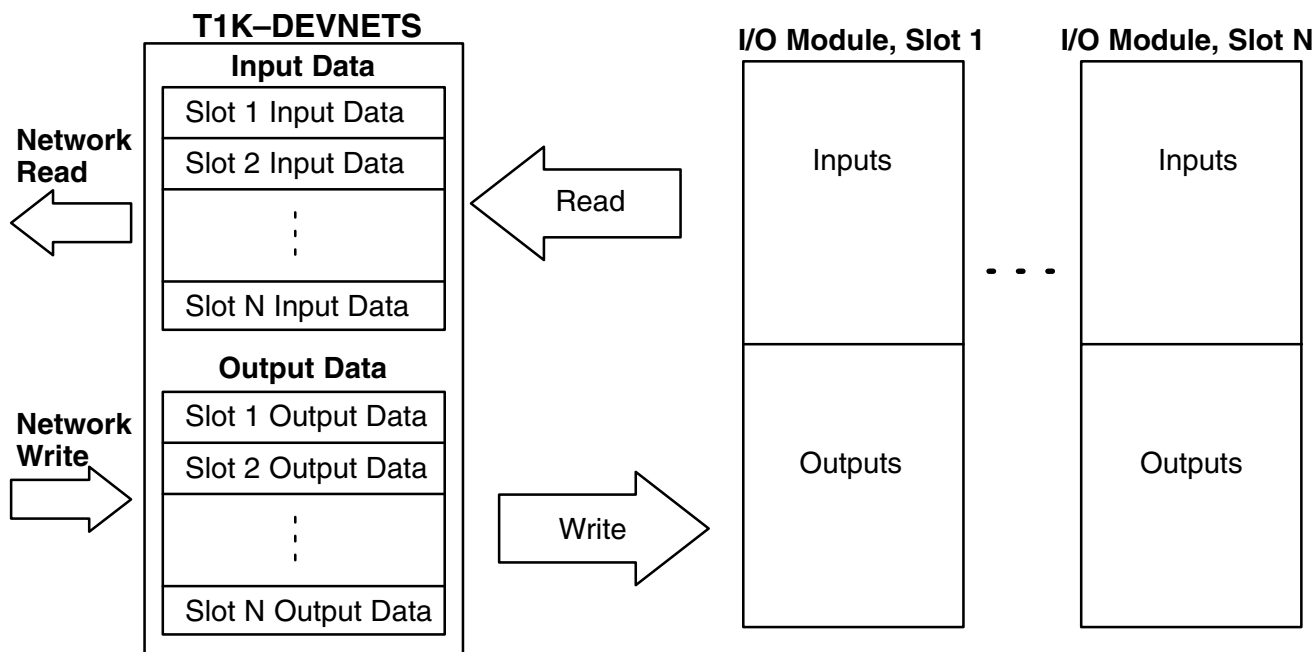

Installing the DeviceNet Base Controller

### I/O Module Memory Map

Refer to the *Terminator I/O Installation and I/O Manual (T1K-INST-M)* for the memory map for individual Discrete and/or Analog I/O Modules.

# Specifications

---

In This Appendix. . . .  
— Specifications

---



## Specifications

General	
Operating Temperature	32° F to 131° F (0° C to 55° C)
Storage Temperature	-4° F to 158° F (-20° C to 70° C)
Ambient Humidity	5% – 95% relative humidity (non-condensing)
Voltage Withstand	1500VAC, 1 minute (DeviceNet connector internal)
Insulation Resistance	500VDC, 10MΩ (DeviceNet connector internal)
Vibration Resistance	MIL STD 810C, Method 514.2
Shock Resistance	MIL STD 810C, Method 516.2
Noise Immunity	NEMA (ICS3-304) Impulse noise 1μs, 1000V FCC class A RFI (145MHz, 435MHz 10W, 10cm)
Atmosphere	No corrosive gases Environmental Pollution Level 2
Size	189"Wx315"Hx326"D (48Wx80Hx83D)
Weight	6.0 oz (170 g)

Communication	
Communication form	DeviceNet Communication Protocol (Slave) Predefined Master/Slave Group 2 Server only
Network Node Address	0 to 63 (Rotary switch setting)
Data Packet	0 to 8 Bytes (Data beyond eight bytes are divided.)
Communication Rate (Max. cable length)	125KB (1640 ft./ 500m) 250KB (820 ft./ 250m) 500KB (328 ft./ 100m)
Communication Status Indicator	MS: Module Status LED [Red/Green] NS: Network Status LED [Red/Green]
DeviceNet Power Consumption	11 to 25 VDC (45mA max.)

DeviceNet	
Device Type	Generic
Explicit Peer to Peer Message	No
I/O Peer to Peer Message	No
Configuration Consistency	No
Fault Node Recovery	No
Communication Baud Rate 125K, 250K, 500K	<b>Yes</b>
Master/Scanner	No
I/O Slave Message	No
Bit Strobe	<b>Yes</b>
Polling	No
Cyclic	No
Change of State	No

<b>Serial Port Communications</b>	
Connector	6 pin female modular (RJ12 phone jack)
Connection Port Type	RS-232C
Protocol	Auto detection K-Sequence (Slave)
Station Number	1 (fixed)
Baud Rate	9600 bps or 19.2 kbps Dip-Switch 6 (DIP SW6) Setting
Data Bits	8
Start Bits	1
Stop Bits	1
Parity	ODD
Communication Time out	Prescribed Time

<b>I/O Modules</b>	
Number of I/O points	Inputs: 1024 Points Outputs: 1024 Points
Number of Slots (I/O Modules)	1 to 16 slots
Self-diagnostics	Watch-dog Timer Memory check
I/O module types	Discrete Input Module Discrete Output Module Analog Input Module Analog Output Module
Install Module	Hot swappable (install / remove modules under power)
Internal Power Consumption	190mA at 5VDC
Max. time of external power loss	10ms

# Tables

---

In This Appendix. . . .  
— DeviceNet Tables

---

# Data Input and Output Tables

## Input Register Object Class (107)

Instance = 1 Attribute = 3

Name	Data	Address	Service
Input Register	Vn+00	+00	Get
	Vn+01	+02	
	Vn+02	+04	
	Vn+03	+06	
	Vn+04	+08	
	:	:	
	Vn+62	+124	
	Vn+63	+ 126	

The Data Register equals one Word (16 bits).  
 A maximum of 64 V-memory words can be accessed.

## Input Register

### Register Input (V-memory) Image Table Mapping

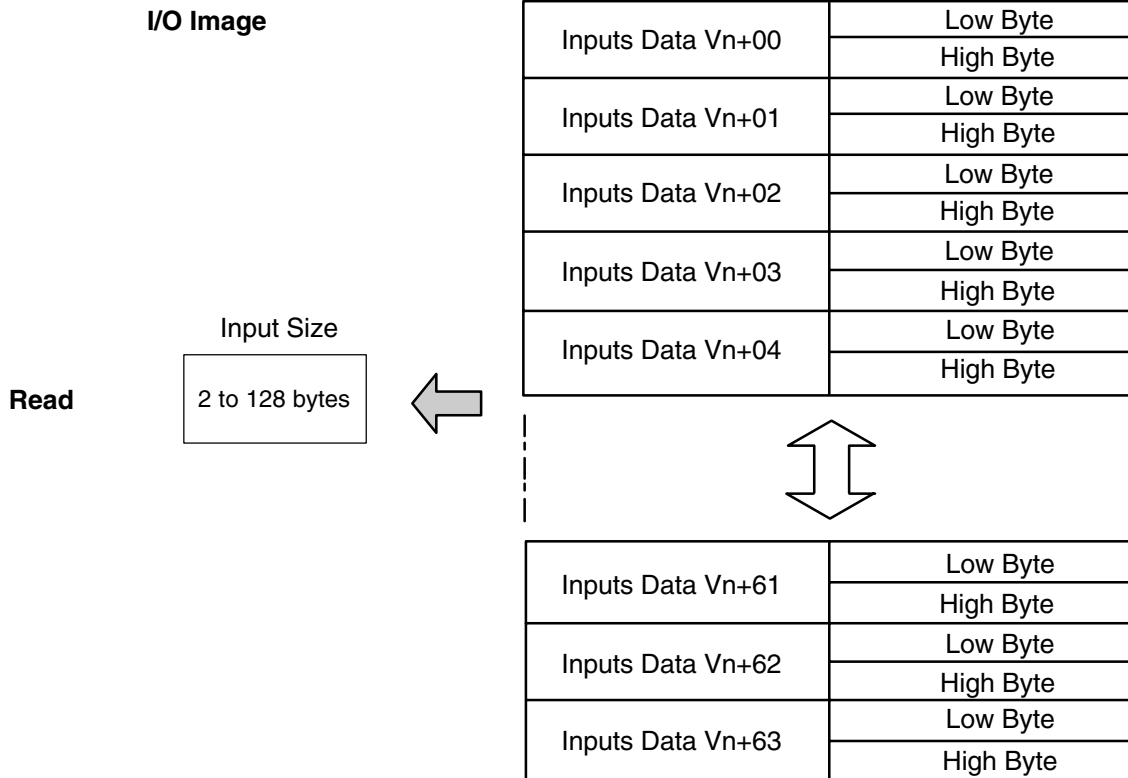

Bit	07	06	05	04	03	02	01	00	Size
	Vn + 00 V memory Low byte data								Read Byte 1
	Vn + 00 V memory High byte data								Read Byte 2
	Vn + 01 V memory Low byte data								Read Byte 3
	Vn + 01 V memory High byte data								Read Byte 4
	Vn + 02 V memory Low byte data								Read Byte 5
	Vn + 02 V memory High byte data								Read Byte 6
	:								:
	:								:
	Vn + 60 V memory Low byte data								Read Byte 121
	Vn + 60 V memory High byte data								Read Byte 122
	Vn + 61 V memory Low byte data								Read Byte 123
	Vn + 61 V memory High byte data								Read Byte 124
	Vn + 62 V memory Low byte data								Read Byte 125
	Vn + 62 V memory High byte data								Read Byte 126
	Vn + 63 V memory Low byte data								Read Byte 127
	Vn + 63 V memory High byte data								Read Byte 128

**Output Register Object Class (108)**

**Instance = 1 Attribute = 3**

Name	Data	Address	Service
Output Register	Vn+00	+00	Set
	Vn+01	+02	
	Vn+02	+04	
	Vn+03	+06	
	Vn+04	+08	
	:	:	
	Vn+62	+124	
	Vn+63	+ 126	

The Data Register equals one Word (16 bits).  
 A maximum of 64 V-memory words can be accessed.

**Output Register**

**Register Output (V-memory) Image Table Mapping**

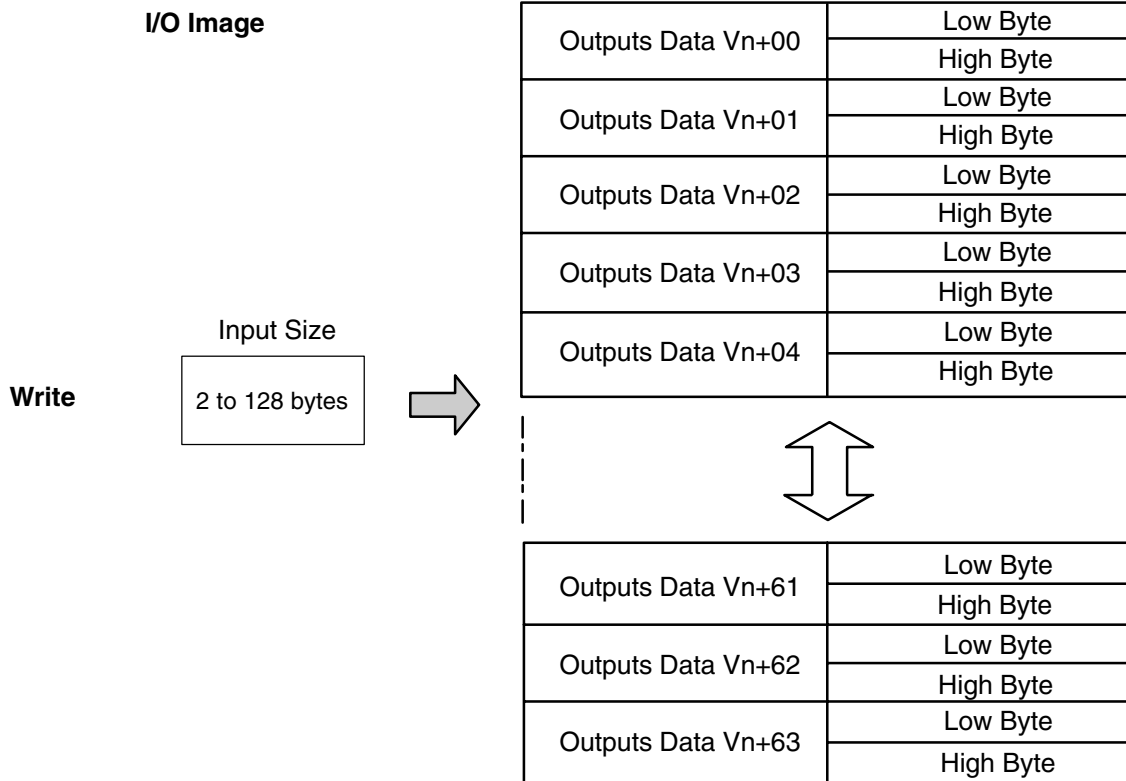

Bit	07	06	05	04	03	02	01	00	Size
	Vn + 00 V memory Low byte data								Write Byte 1
	Vn + 00 V memory High byte data								Write Byte 2
	Vn + 01 V memory Low byte data								Write Byte 3
	Vn + 01 V memory High byte data								Write Byte 4
	Vn + 02 V memory Low byte data								Write Byte 5
	Vn + 02 V memory High byte data								Write Byte 6
	:								:
	:								:
	Vn + 60 V memory Low byte data								Write Byte 121
	Vn + 60 V memory High byte data								Write Byte 122
	Vn + 61 V memory Low byte data								Write Byte 123
	Vn + 61 V memory High byte data								Write Byte 124
	Vn + 62 V memory Low byte data								Write Byte 125
	Vn + 62 V memory High byte data								Write Byte 126
	Vn + 63 V memory Low byte data								Write Byte 127
	Vn + 63 V memory High byte data								Write Byte 128

## Data Register Range

RJ12 serial port supports the following registers.

No.	Register Number	Comment	Description
1	V40400–V40477	Input Register	Read/Write
2	V40500–V40577	Output Register	Read/Write
3	V00000–V02777	Data Register	Read/Write
4	V03000–V03077	Explicit Get Command Area	Read/Write
5	V03100–V03177	Explicit Set Command Area	Read/Write
6	V03200–V07377	Data Register	Read/Write
7	V07640–V07613	Special Register	Resave
8	V07614–V07617	Parameter Register	Read
9	V07620–V07777	Special Register	Resave

Note: Not all registers back up data.

# I/O Diagnostic Information

## DIP Switch SW4

The position of DIP Switch SW4 determines whether or not you receive Terminator I/O diagnostic information. If SW4 is in the OFF (default) position, you will receive this diagnostic information and you must allow for two additional bytes on the input (RX) and two additional bytes on the output (TX) for Terminator I/O diagnostic functions.

If SW4 is placed in the ON position, you will not receive this diagnostic information and there is no need to allow for the additional bytes.

Following is a description of the diagnostic codes.

Diagnostic (polling) information when T1K-DEVNETS (slave) transmits to a master.

Address	Bytes	Data	Comment
+0	1	I/O Status	Bit 0: Missing module error ON: Error / OFF: Normal
			Bit 1: New module present error ON: Error / OFF: Normal
			Bit 2: I/O diagnostic error ON: Error / OFF: Normal
			Bit 3: Node error (the node number has changed) ON: Error / OFF: Normal
			Bit 4: Idle (Output is idle) ON: Idle / OFF: Normal
			Bit 5: Multiple error (Two or more errors occurred) ON: Multiple / OFF: Normal
			Bit 7: Output status ON: Enable / OFF: Disable
+1	1	Error Slot	01h: Slot 1 02h: Slot 2 . . . 1Fh: Slot 31
			21h: Slot 1 22h: Slot 2 . . . 3Fh: Slot 31
			Module Missing error or New Module Error
			24V Error or Fuse Error
			The slot number in which the error has occurred. When the same error occurs by multiple slots, priority is given to low slot number. Priority is given to 24V Error or Fuse Error when multiple errors occur at the same time.
+2 . +nn	n	Bit Data	T1K-DEVNETS input module data.



Diagnostic (polling) information when a master transmits to a T1K-DEVNETS (slave). The command to select I/O configuration is transferred from peripheral and written here. When the I/O configuration error occurs the command is executed.

Address	Bytes	Data	Comment
+0	1	Code of except the following	No request
		5Ah	Select I/O reconfiguration
		C3h	Select Output Enable
		3Ch	Select Output Disable
+1	1	Reserved	Not used
+2 . +nn	n	Bit data	T1K-DEVNETS output module data.

**System Information Object Specifications**

DeviceNet object that T1K-DEVNETS supports are:

Item		Instance	Class Number
Special Object	System Information Object	1-4	106

# Image Table Mapping

---

In This Appendix. . . .  
— Image Table Mapping

---

# Image Table Mapping

## Read, Write and Status Byte References

T1K-DEVNETS can access data bytes.

### Discrete Input

#### Discrete Input Point (X,Y,C,S,T,CT,SP) Image Table Mapping

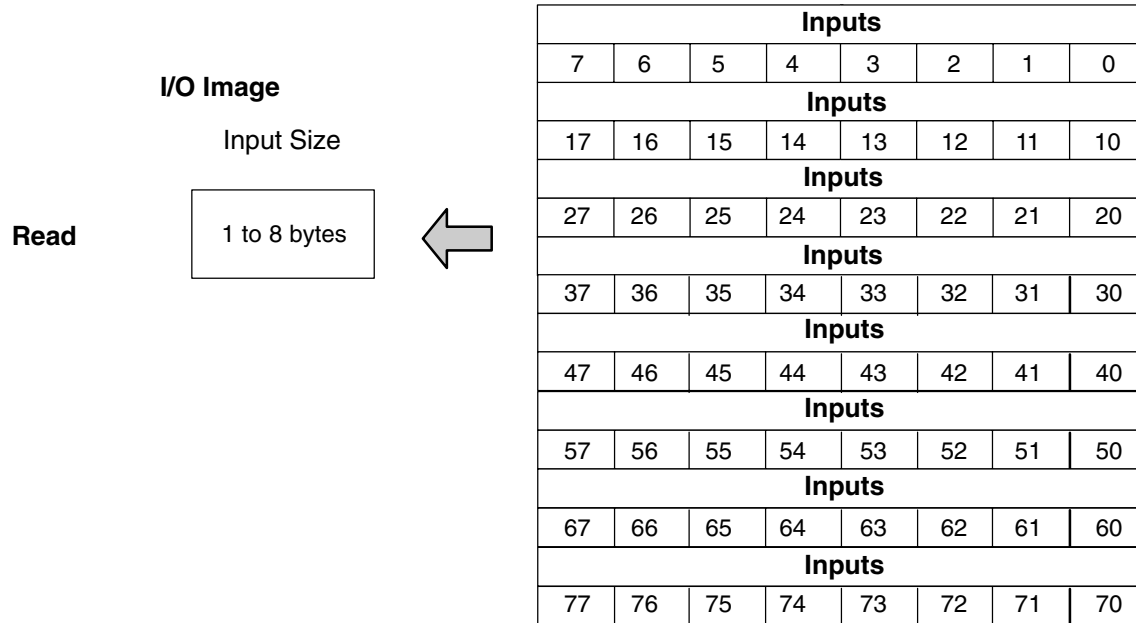

Dec. Bit	07	06	05	04	03	02	01	00	Size
Oct. Bit	07	06	05	04	03	02	01	00	
	7	6	5	4	3	2	1	0	Read Byte 1
	17	16	15	14	13	12	11	10	Read Byte 2
	27	26	25	24	23	22	21	20	Read Byte 3
	37	36	35	34	33	32	31	30	Read Byte 4
	47	46	45	44	43	42	41	40	Read Byte 5
	57	56	55	54	53	52	51	50	Read Byte 6
	67	66	65	64	63	62	61	60	Read Byte 7
	77	76	75	74	73	72	71	70	Read Byte 8
	Not Supported								Write Byte 1

**Discrete Output Point (X,Y,C,S,T,CT,SP) Image Table Mapping**

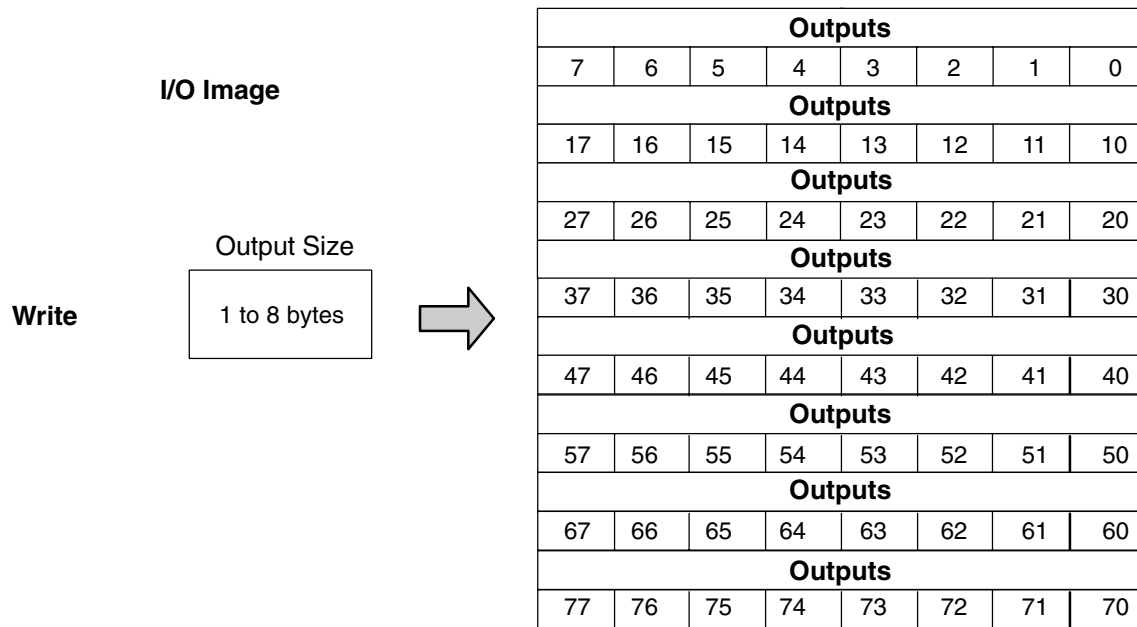

Dec. Bit	07	06	05	04	03	02	01	00	Size
Oct. Bit	07	06	05	04	03	02	01	00	Size
	Not Supported								Read Byte 1
	7	6	5	4	3	2	1	0	Write Byte 1
	17	16	15	14	13	12	11	10	Write Byte 2
	27	26	25	24	23	22	21	20	Write Byte 3
	37	36	35	34	33	32	31	30	Write Byte 4
	47	46	45	44	43	42	41	40	Write Byte 5
	57	56	55	54	53	52	51	50	Write Byte 6
	67	66	65	64	63	62	61	60	Write Byte 7
	77	76	75	74	73	72	71	70	Write Byte 8

**Register Input (V-memory) Image Table Mapping**

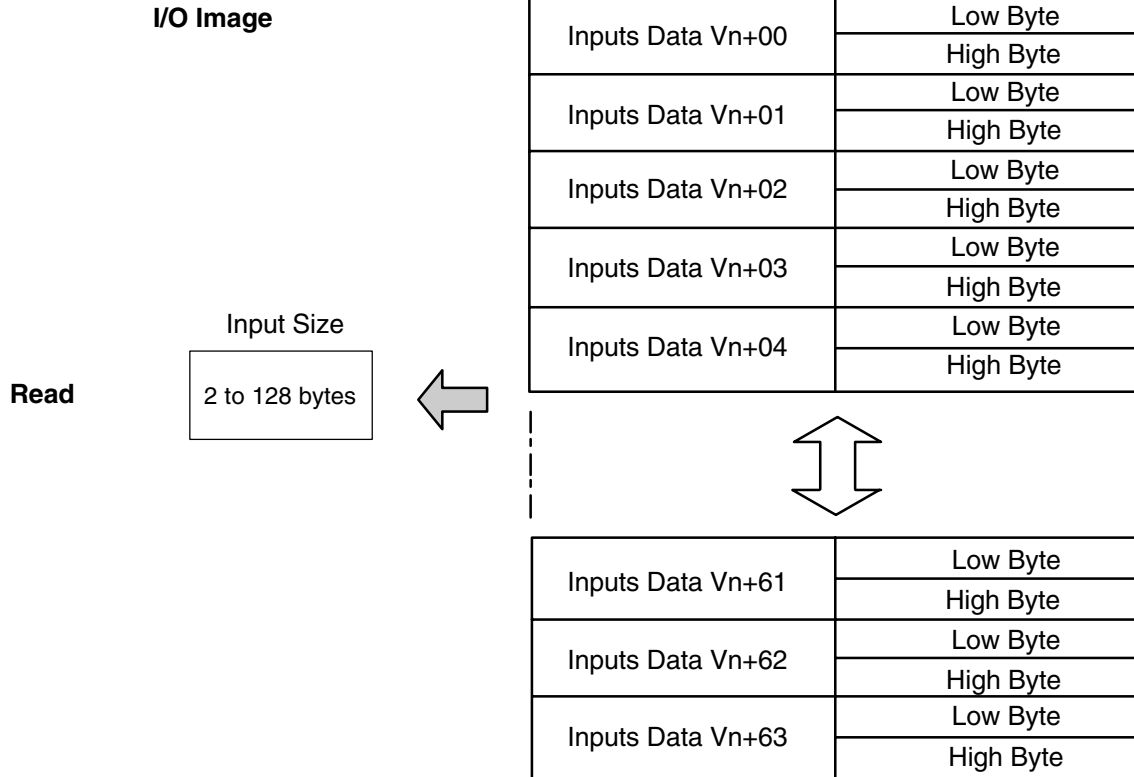

Bit	07	06	05	04	03	02	01	00	Size
	Vn + 00 V memory Low byte data								Read Byte 1
	Vn + 00 V memory High byte data								Read Byte 2
	Vn + 01 V memory Low byte data								Read Byte 3
	Vn + 01 V memory High byte data								Read Byte 4
	Vn + 02 V memory Low byte data								Read Byte 5
	Vn + 02 V memory High byte data								Read Byte 6
	Vn + 03 V memory Low byte data								Read Byte 7
	Vn + 03 V memory High byte data								Read Byte 8
	Vn + 04 V memory Low byte data								Read Byte 9
	Vn + 04 V memory High byte data								Read Byte 10
	Vn + 05 V memory Low byte data								Read Byte 11
	Vn + 05 V memory High byte data								Read Byte 12
	Vn + 06 V memory Low byte data								Read Byte 13
	Vn + 06 V memory High byte data								Read Byte 14
	Vn + 07 V memory Low byte data								Read Byte 15
	Vn + 07 V memory High byte data								Read Byte 16

	Vn + 08 V memory Low byte data	Read Byte 17
	Vn + 08 V memory High byte data	Read Byte 18
	Vn + 09 V memory Low byte data	Read Byte 19
	Vn + 09 V memory High byte data	Read Byte 20
	:	:
	:	:
	:	:
	:	:
	Vn + 30 V memory Low byte data	Read Byte 61
	Vn + 30 V memory High byte data	Read Byte 62
	Vn + 31 V memory Low byte data	Read Byte 63
	Vn + 31 V memory High byte data	Read Byte 64
	:	:
	:	:
	:	:
	:	:
	Vn + 60 V memory Low byte data	Read Byte 121
	Vn + 60 V memory High byte data	Read Byte 122
	Vn + 61 V memory Low byte data	Read Byte 123
	Vn + 61 V memory High byte data	Read Byte 124
	Vn + 62 V memory Low byte data	Read Byte 125
	Vn + 62 V memory High byte data	Read Byte 126
	Vn + 63 V memory Low byte data	Read Byte 127
	Vn + 63 V memory High byte data	Read Byte 128
	Not Supported	Write Byte 1

**Register Output (V-memory) Image Table Mapping**

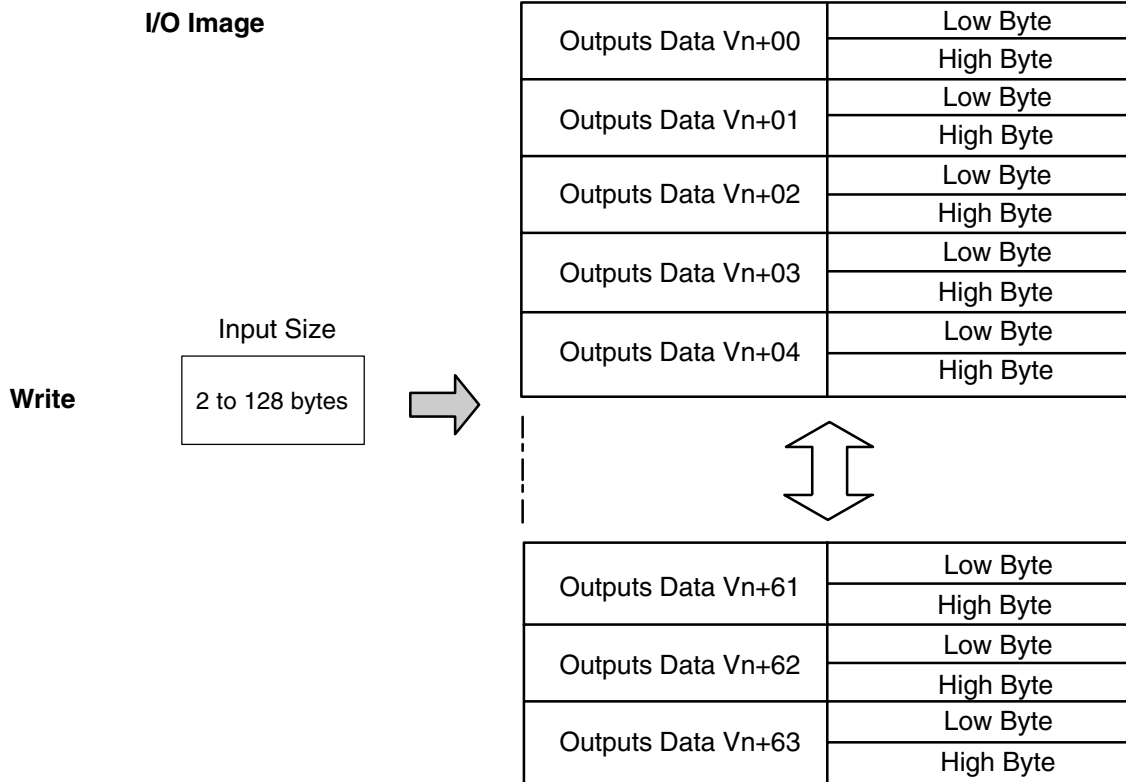

Bit	07	06	05	04	03	02	01	00	Size
	Not Supported								Read Byte 1
	Vn + 00 V memory Low byte data								Write Byte 1
	Vn + 00 V memory High byte data								Write Byte 2
	Vn + 01 V memory Low byte data								Write Byte 3
	Vn + 01 V memory High byte data								Write Byte 4
	Vn + 02 V memory Low byte data								Write Byte 5
	Vn + 02 V memory High byte data								Write Byte 6
	Vn + 03 V memory Low byte data								Write Byte 7
	Vn + 03 V memory High byte data								Write Byte 8
	Vn + 04 V memory Low byte data								Write Byte 9
	Vn + 04 V memory High byte data								Write Byte 10
	Vn + 05 V memory Low byte data								Write Byte 11
	Vn + 05 V memory High byte data								Write Byte 12
	Vn + 06 V memory Low byte data								Write Byte 13
	Vn + 06 V memory High byte data								Write Byte 14
	Vn + 07 V memory Low byte data								Write Byte 15
	Vn + 07 V memory High byte data								Write Byte 16

	Vn + 08 V memory Low byte data	Write Byte 17
	Vn + 08 V memory High byte data	Write Byte 18
	Vn + 09 V memory Low byte data	Write Byte 19
	Vn + 09 V memory High byte data	Write Byte 20
	:	:
	:	:
	:	:
	:	:
	Vn + 30 V memory Low byte data	Write Byte 61
	Vn + 30 V memory High byte data	Write Byte 62
	Vn + 31 V memory Low byte data	Write Byte 63
	Vn + 31 V memory High byte data	Write Byte 64
	:	:
	:	:
	:	:
	:	:
	Vn + 60 V memory Low byte data	Write Byte 121
	Vn + 60 V memory High byte data	Write Byte 122
	Vn + 61 V memory Low byte data	Write Byte 123
	Vn + 61 V memory High byte data	Write Byte 124
	Vn + 62 V memory Low byte data	Write Byte 125
	Vn + 62 V memory High byte data	Write Byte 126
	Vn + 63 V memory Low byte data	Write Byte 127
	Vn + 63 V memory High byte data	Write Byte 128



# PLC Mode Image Table Mapping

I/O Image

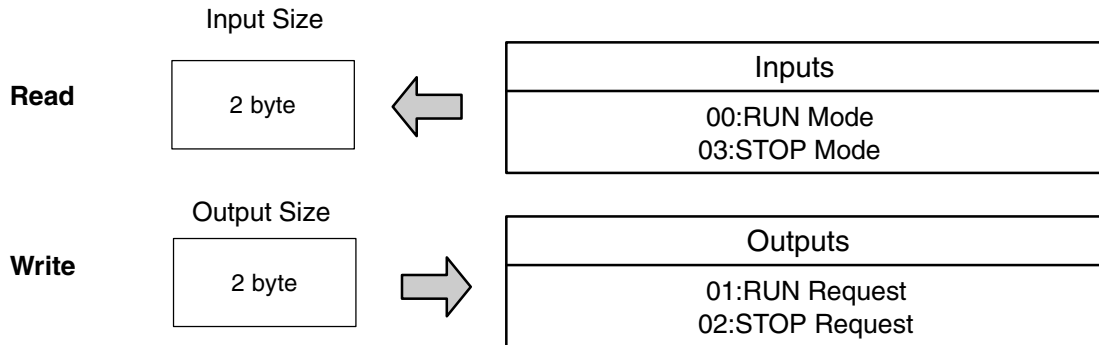

Dec. Bit	07	06	05	04	03	02	01	00	Size
Oct. Bit	07	06	05	04	03	02	01	00	
RUN Mode	0	0	0	0	0	0	0	0	Read Byte 2
STOP Mode	0	0	0	0	0	0	1	1	
RUN Request	0	0	0	0	0	0	0	1	Write Byte 2
STOP Request	0	0	0	0	0	0	1	0	

Appendix C  
Image Table Mapping

## Adapter Input/Output Status Word

Polling format that the T1K-DEVNETS (slave) transmits to a master.

Address	Bytes	Data	Comment
+ 0	1	I/O Status	Bit 0: Not used Bit 1: Not used Bit 2: Not used Bit 3: Node Error (Node number has changed) ON: Error/OFF: Normal Bit 4: IDLE (Output is IDLE) ON: Idle/OFF: Normal Bit 7: OUTPUT Status ON: Disable/OFF: Enable
+ 1	1	PLC Mode	00h: Mode = STOP 03h: Mode = RUN

Polling format that a master transmits to a DO-DEVNETS (slave).

Address	Bytes	Data	Comment
+ 0	1	No Code	No request
		C3h	Enable OUTPUT
		3Ch	Disable OUTPUT
+ 1	1	PLC Mode	01h: RUN request 02h: STOP request

# **T1K–DEVNETS Think & Do Setup**

---

In This Appendix. . . .  
— T1K–DEVNETS T & D Setup

## T1K-DEVNETS Think & Do Setup

For those who are using the T1K-DEVNETS as a slave with Think & Do Studio, the following example shows how to setup Think & Do on your network.

### T & D Studio setup for PC control

Use the following procedure to setup the T1K-DEVNETS adapter with Think & Do Studio. Be sure that the Node Address switches have been set to a proper address.

1. Click on Add Driver and SST card is installed.
2. Set MAC ID to 62.
3. Set baud rate (500K, SW1-1 OFF, -2 ON, in this example).
4. Set scanner interval to 0.
5. Set timeout shutdown to 5.
6. EDS not needed.

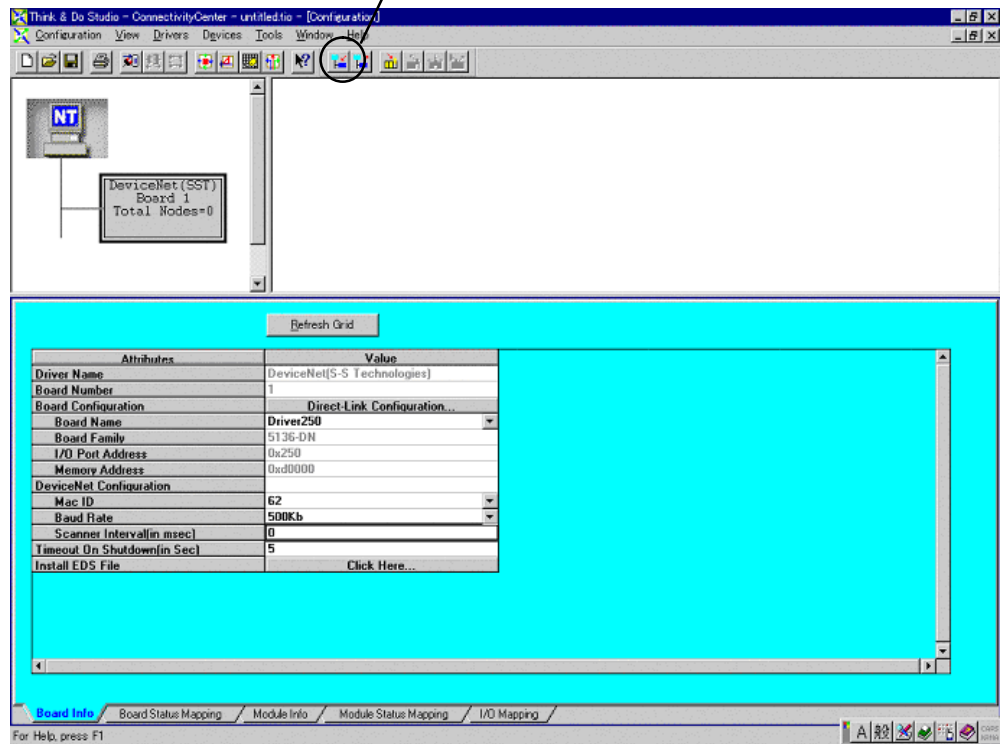

7. Click on connection.

Think & Do will display T1K-DEVNETS MacID-2. Inputs and outputs are displayed.

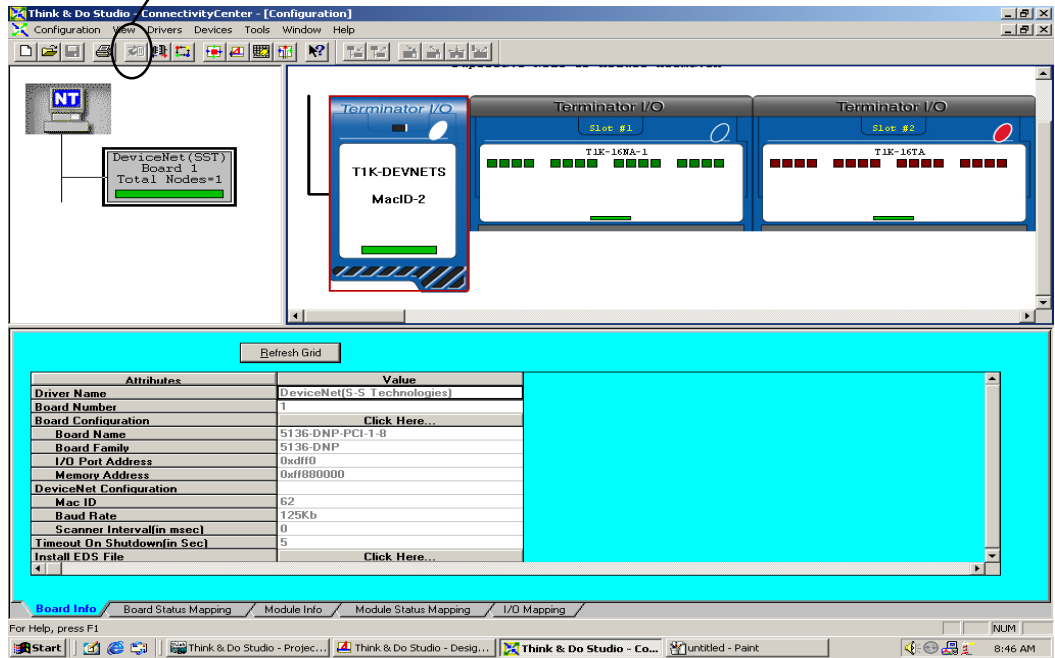

8. Click on Scan and communication will begin.

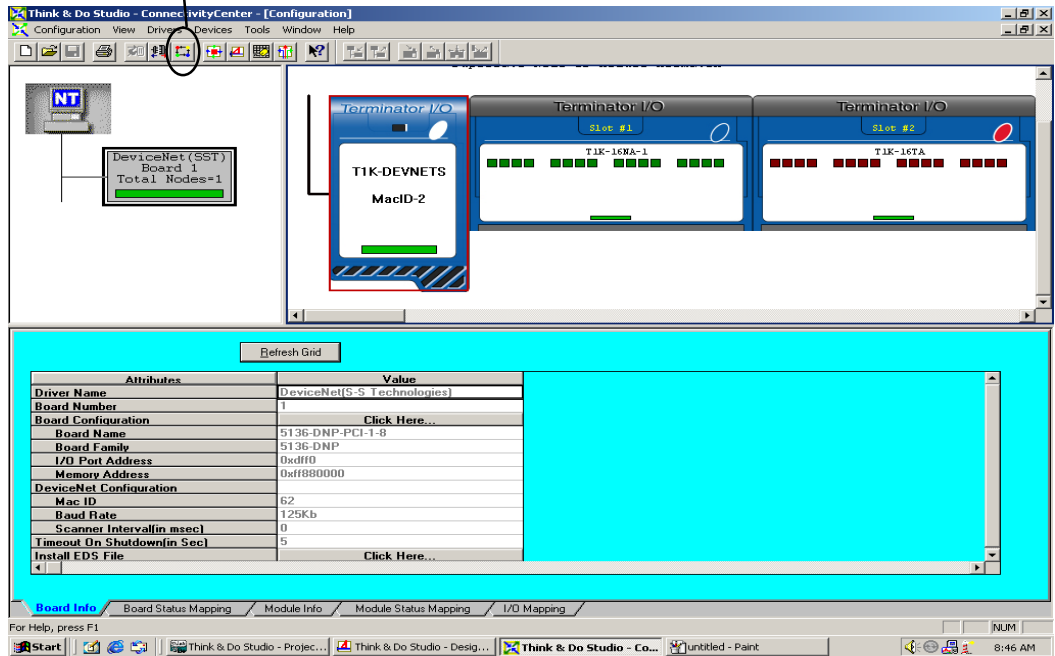

# T1K-DEVNETS and RSNetWorx™ Setup

---

In this Appendix. . . .

— Setup T1K-DEVNETS with RSNetWorx™

## Setup T1K-DEVNETS with RSNetWorx™

For those who are using the T1K-DEVNETS as a slave with an Allen-Bradley PLC, the examples on the following pages have worked for us, and will be a guide for you. These steps should help you through the process of setting up your Allen-Bradley DeviceNet network using RSNetWorx™. If you encounter any difficulties with the setup process, please contact your local Rockwell International representative.

### RSLink

Begin by opening your RSLink to configure the DeviceNet driver.

1. Click on **Communications**.
2. Click on **Configure Drivers**.

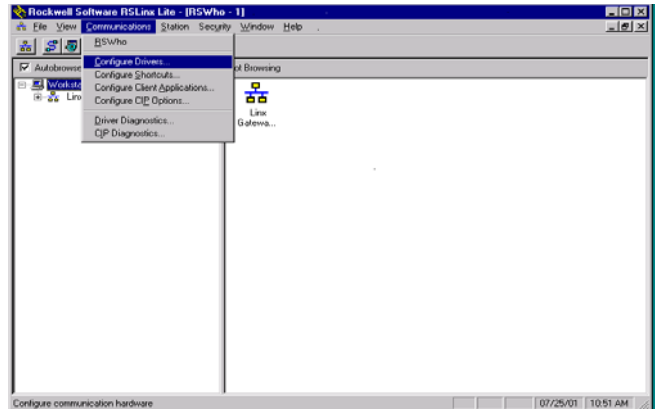

3. Click on the down arrowhead, ▼, and select a driver from the drop-down list.
4. Click **Add New**.

A DF1 driver is selected in this example.

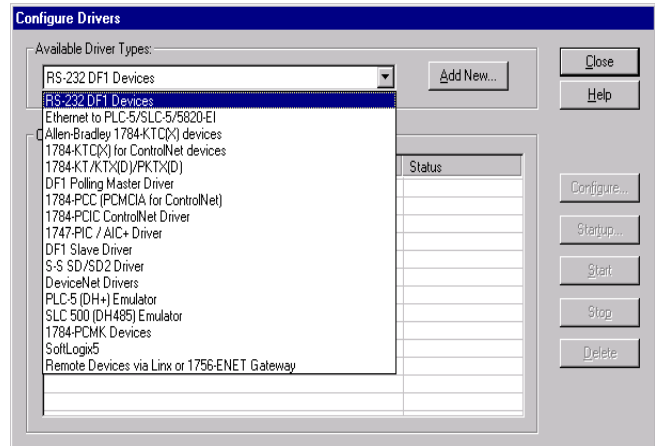

**Note:** Selecting a new driver may prompt you to reboot or to restart your computer.



- Click **OK** in the pop-up window.

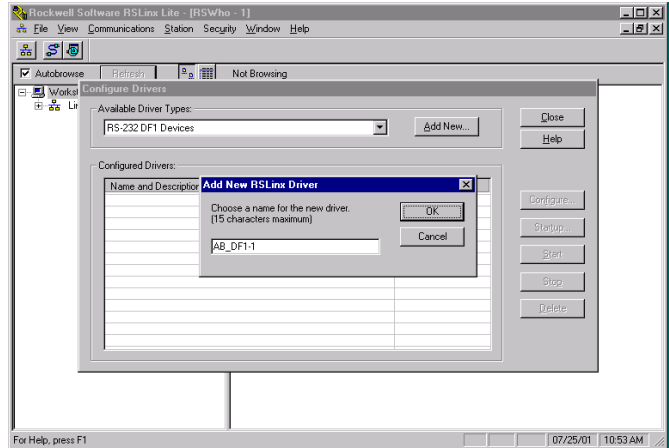

- This window will appear.
- Click on **Auto-Configure** to setup the communication parameters.

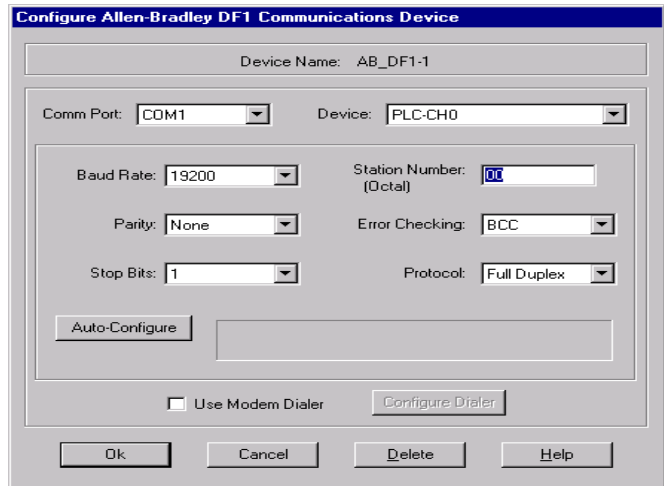

- Auto Configuration Successful will appear.
- Click **OK**.

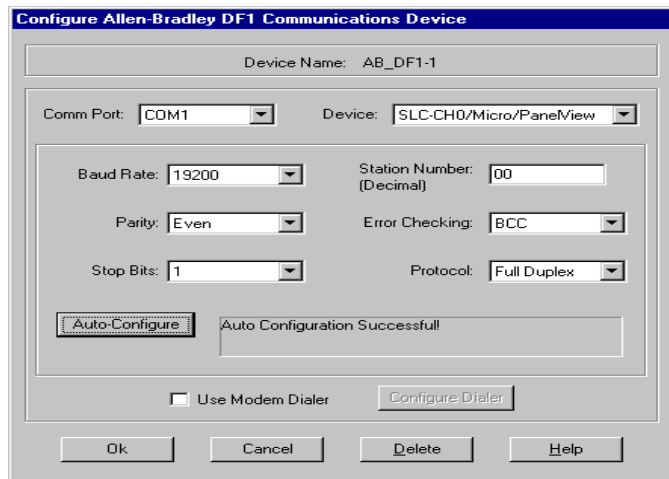

The Configure Drivers window will now appear showing the **Status** as Running.

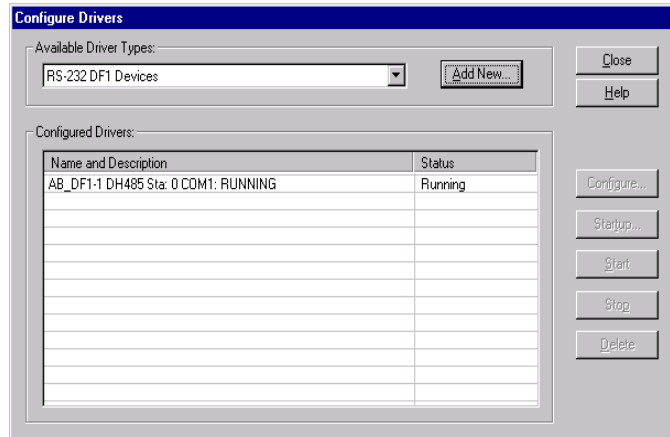

The next step is to add a DeviceNet driver.

8. Click on the down arrowhead, ▼, and select your choice of drivers from the drop-down list.
9. Click on **Add New**.

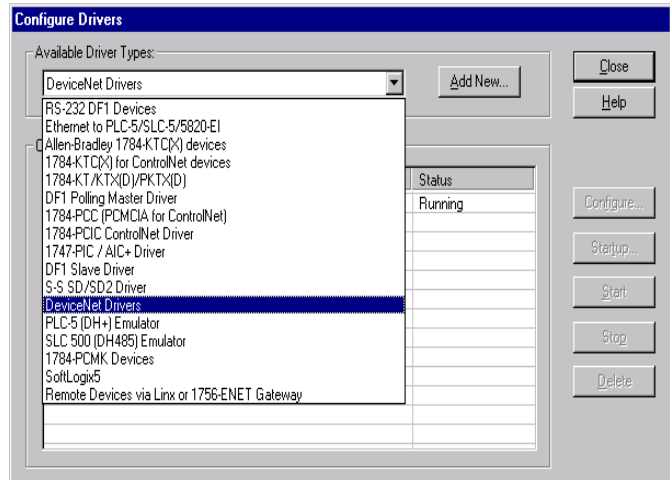

This window will appear.

10. Select the proper driver, then click **Select**.

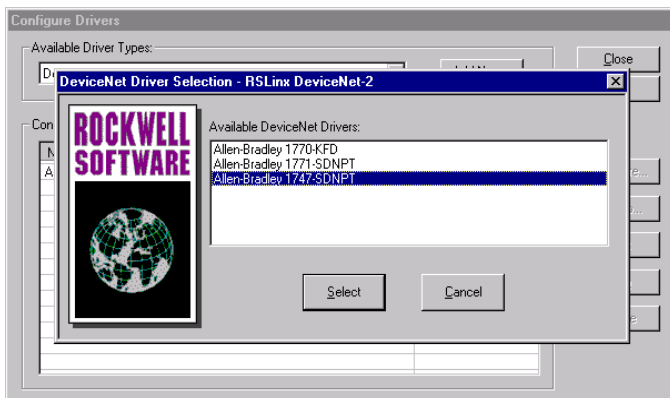



The DeviceNet Interface Configuration window will appear briefly.

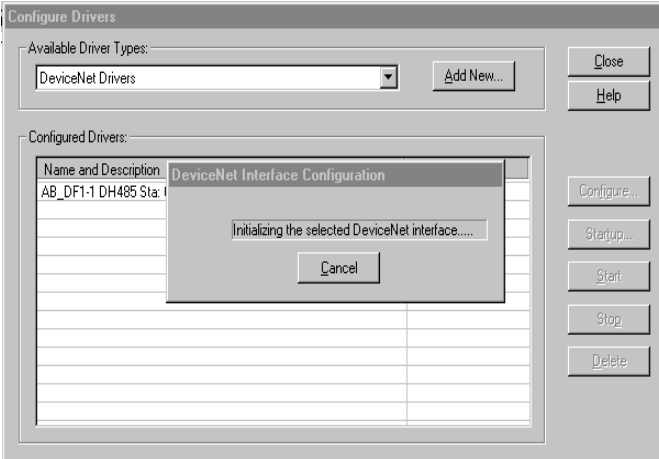

This window will appear for you to setup the pass through port.

Be sure that you select the proper slot where the scanner module is located.

If this does not match, you will need to reconfigure the I/O in RSLogix.

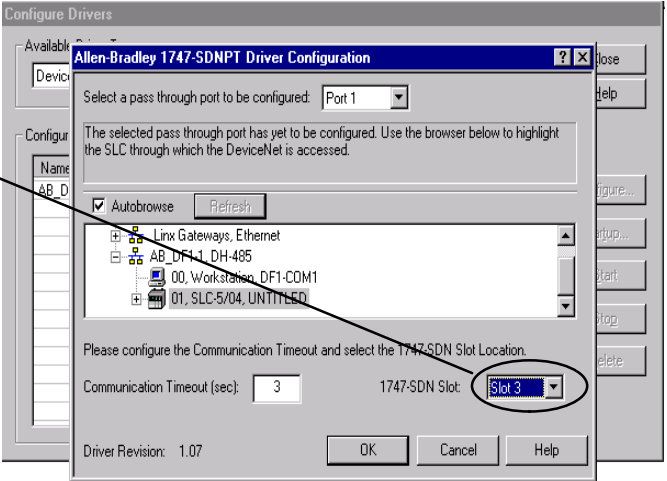

11. Type in a name for the driver, then click **OK**.

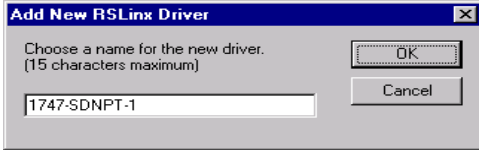

This window will appear indicating that both drivers are Running.

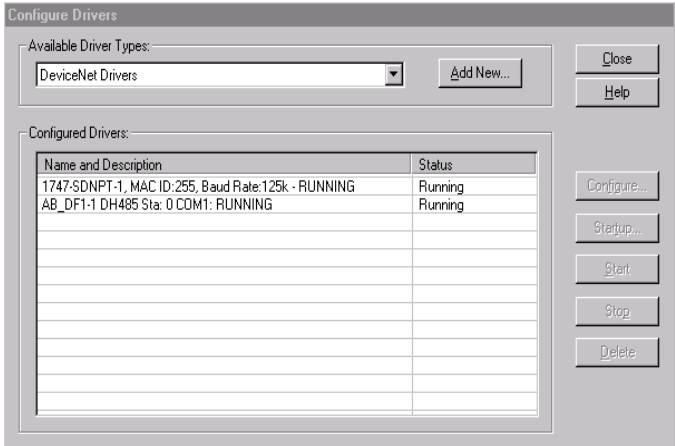

### RSLogix

You are ready to connect to the PLC using your RSLogix software.

1. Click on **Communications** and select **Who Active Go Online**.

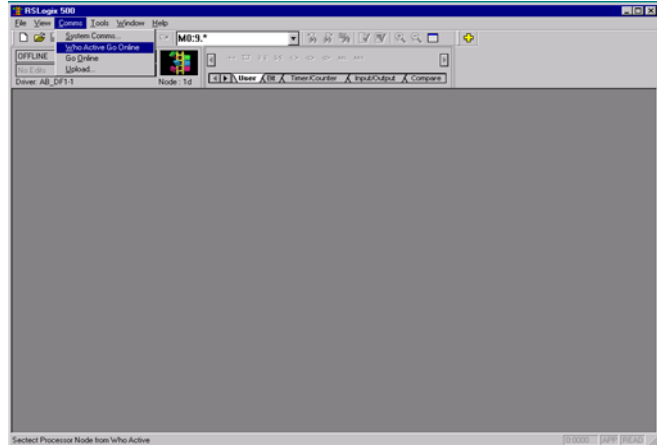

2. When this window appears, select the PLC to connect to.
3. Click **OK**.

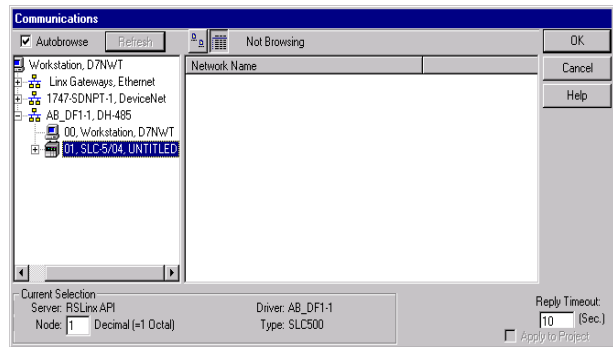

- This window will appear with the relay ladder program. You now want to configure the I/O. This must be done **OFFLINE** in order to change the configuration.
4. Select **I/O Configuration**.

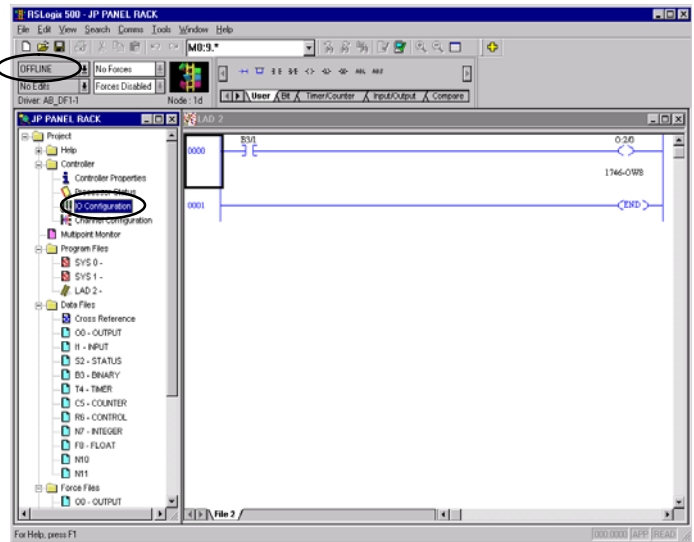

The I/O Configuration window will come into view. When you select the scanner module, verify that it is in the correct slot.

5. Click **Adv Config**.

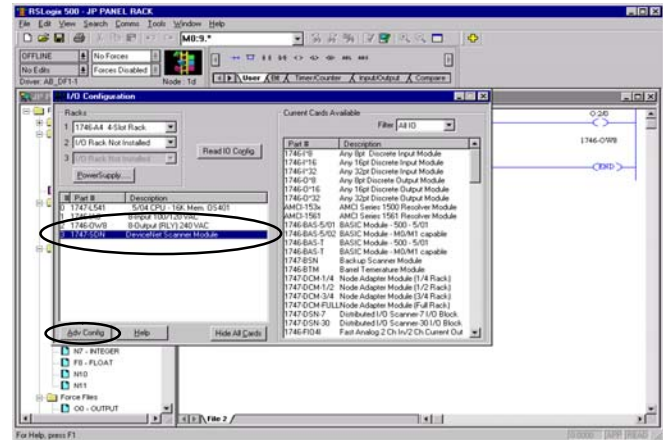

The **Advanced I/O Configuration** window will appear. The **M0** and **M1** Lengths will show the default of 256. Change this to 361.

6. Click **OK**.

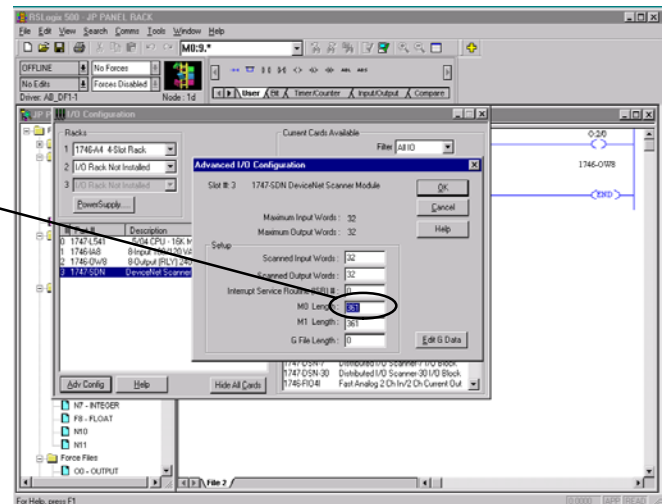

## Configure T1K-DEVNETS with RSNetWorx

You are now ready to configure the T1K-DEVNETS. First, open RSNetWorx. Look for Koyo Electronics in the hardware tree listed under **Vendor**. Click on the + to show the devices for Koyo. The following example shows two devices, D0-DEVNETS and T1K-DEVNETS.

RSNetWorx opened.

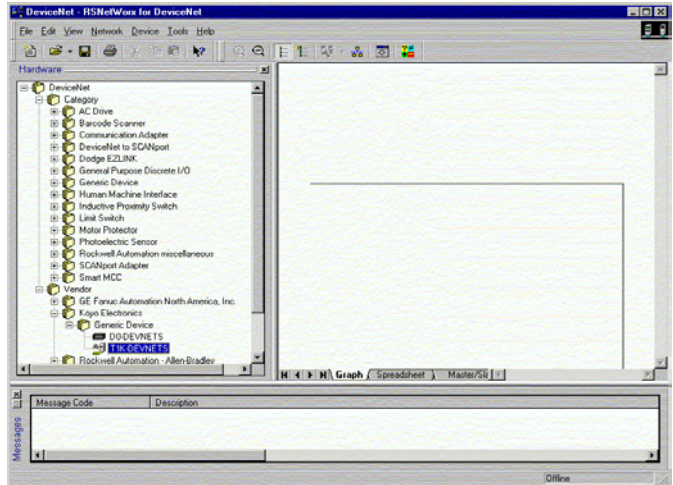

## Using the EDS file

If you do not see your device listed, it will need to be added from the EDS file (refer to page 2-8). The following example will guide you through the procedure of installing the device from the EDS file.

Click **Tools** and select **EDS Wizard...**

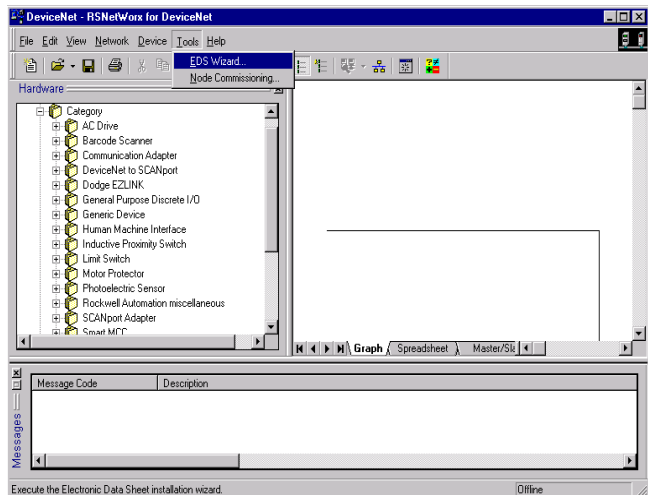

The EDS Wizard will open. Simply follow the instructions to register the device.

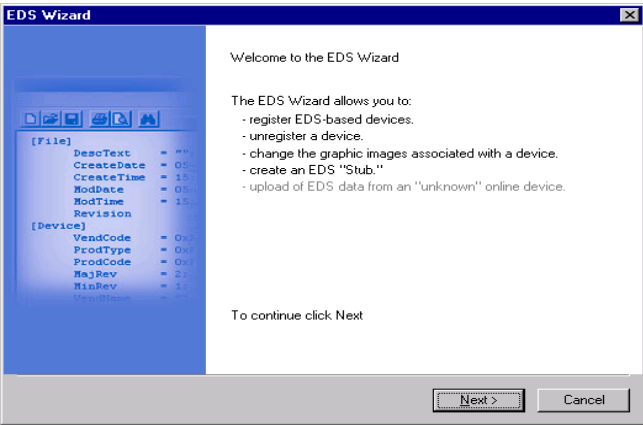

Register the EDS file.

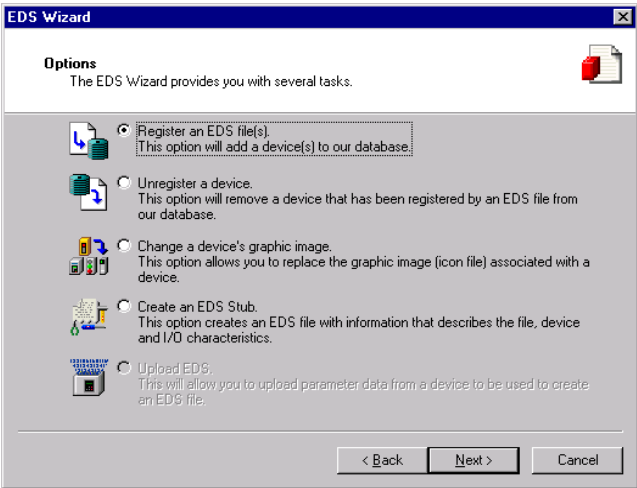

Enter the path for the EDS file.

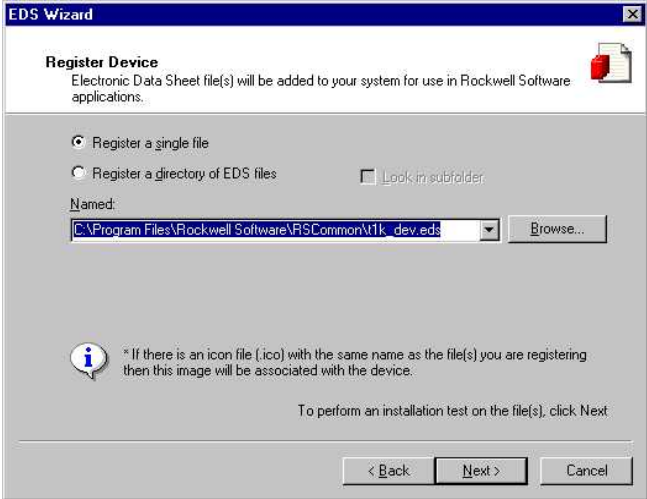

EDS file installation results.

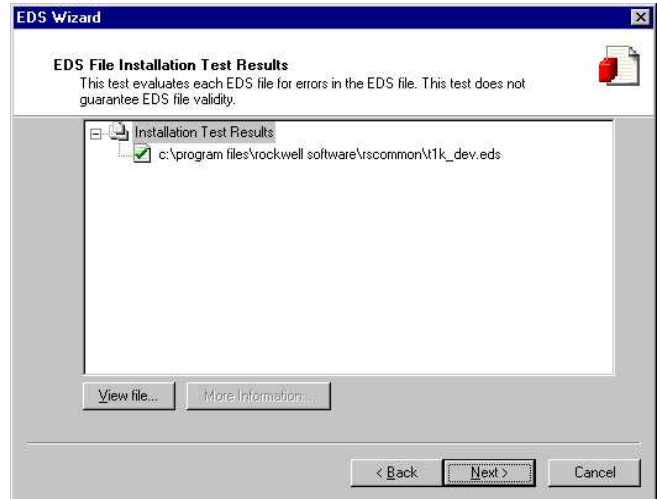

You can change the icon image for your device in this window.

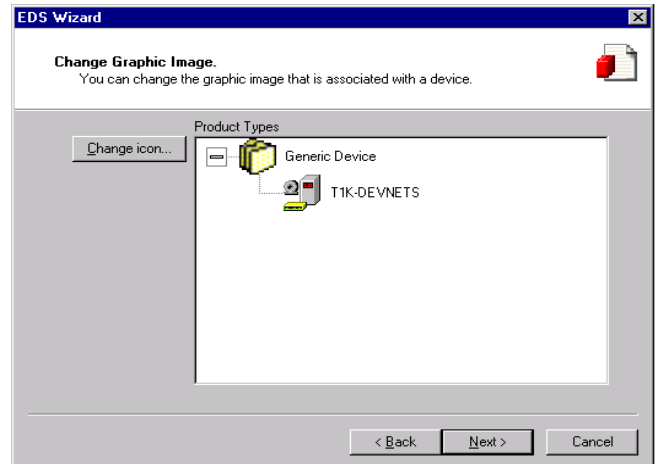

Review what you have done.

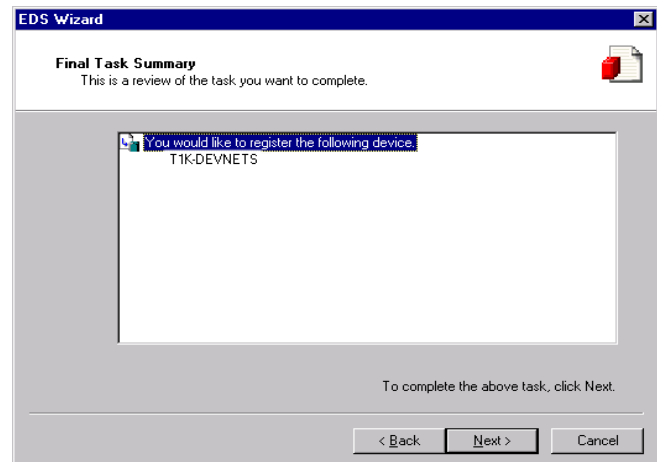

EDS Wizard complete.

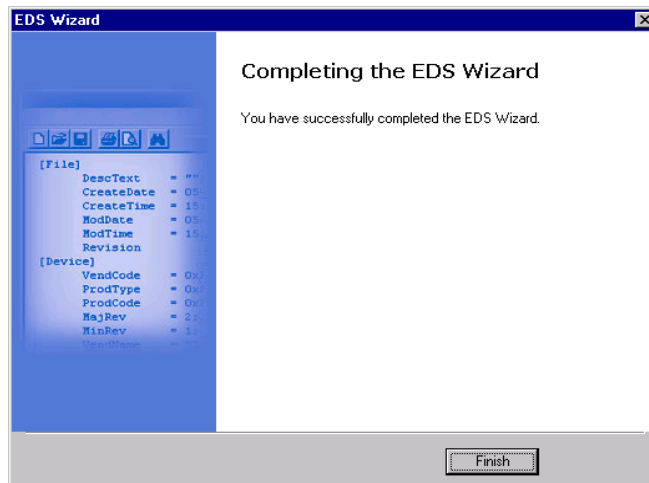

## Go on line

You will want to go on line with the network now.

In the main RSNetWorx window,

1. Click on **Network** to select **Online**.

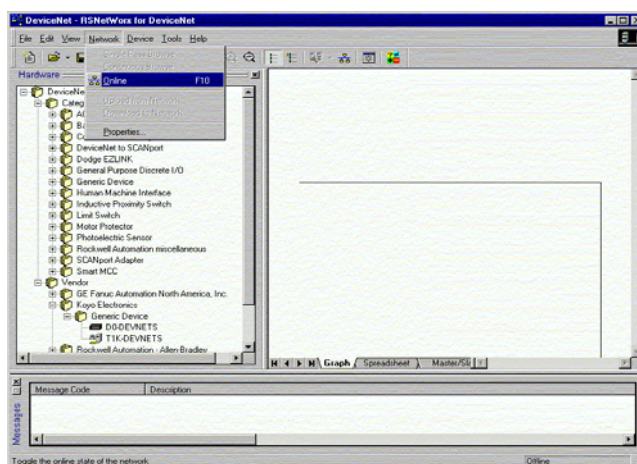

2. Select your network from the pop-up window.

3. Click **OK**.

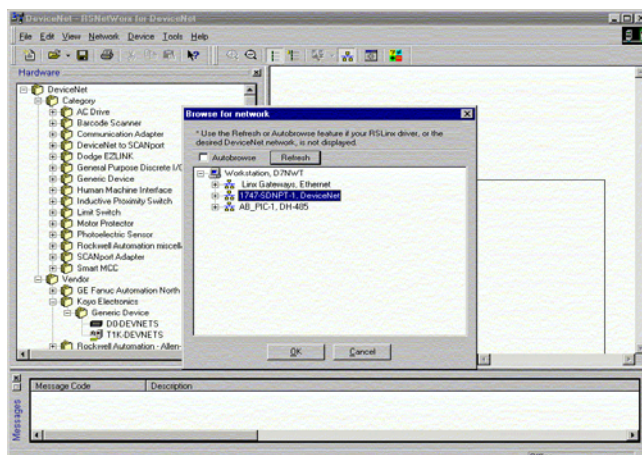

This message will appear.

4. Click **OK**.



Browsing network message.

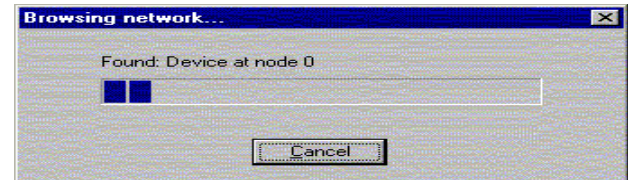

Once the nodes are found, each node icon will appear on the RSNetWorx window.

After all of the nodes have been found, browse can be cancelled.

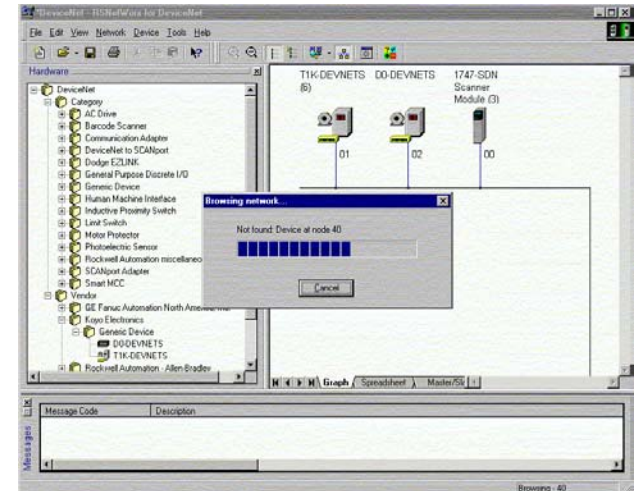

### Set up I/O parameters

Now you can set up the I/O parameters for the devices. The scanner needs to be configured first. This is done by accessing the scanner properties.

1. Selecting the scanner module can be done in two different ways. Either click on the scanner name and right click the mouse or click on **Device** then click on **Properties** in the pop-up window.

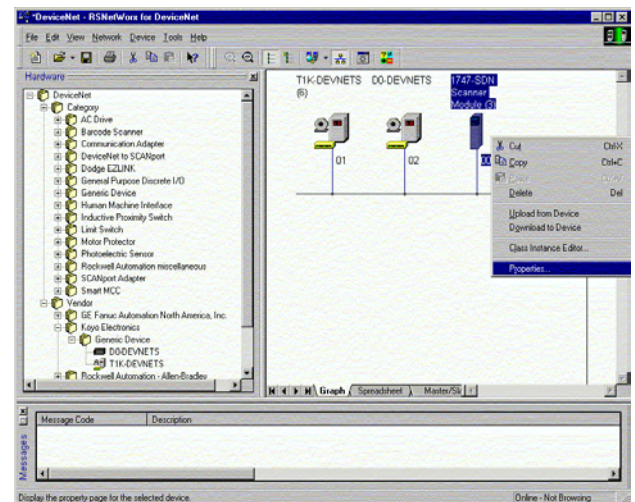



The properties window will appear.

2. Click **Module**.

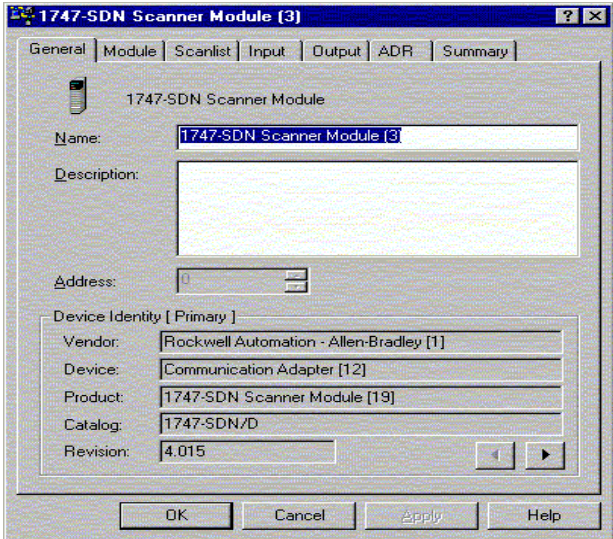

3. Click **Upload**.

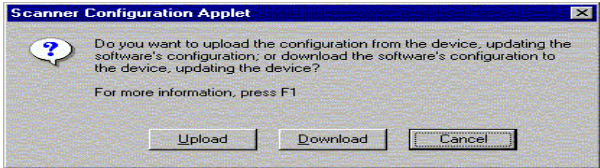

Uploading network information.

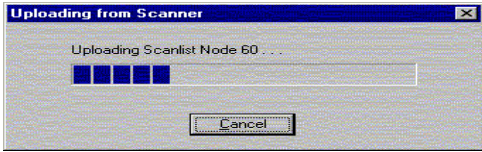

**Note:** Do not cancel. The entire network data must be allowed to upload.

The data appears.

- 4. Select the correct slot number which the DeviceNet scanner module is residing.
- 5. Click **Scanlist**.

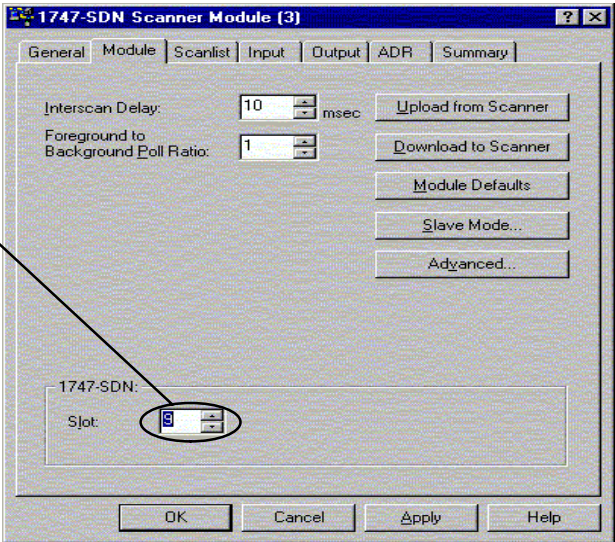

If the node that you want is not in the Scanlist, it needs to be moved to the list.

6. Highlight T1K-DEVNETS
7. Click the right arrow.

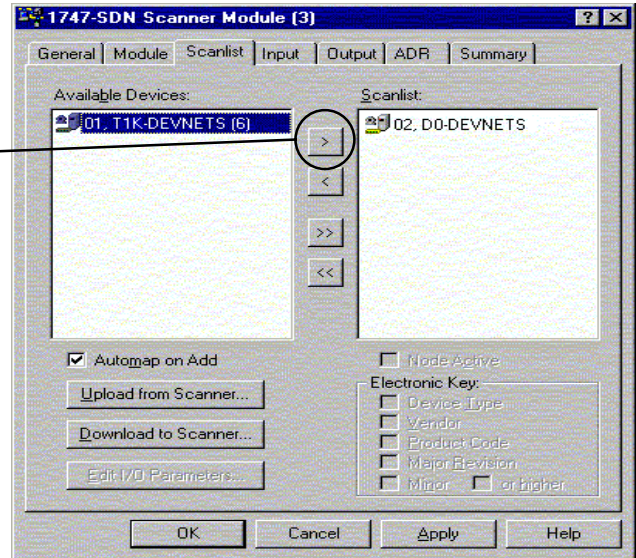

Now that T1K-DEVNETS is in the list, be sure that it is selected.

8. Click **Edit I/O Parameters**.

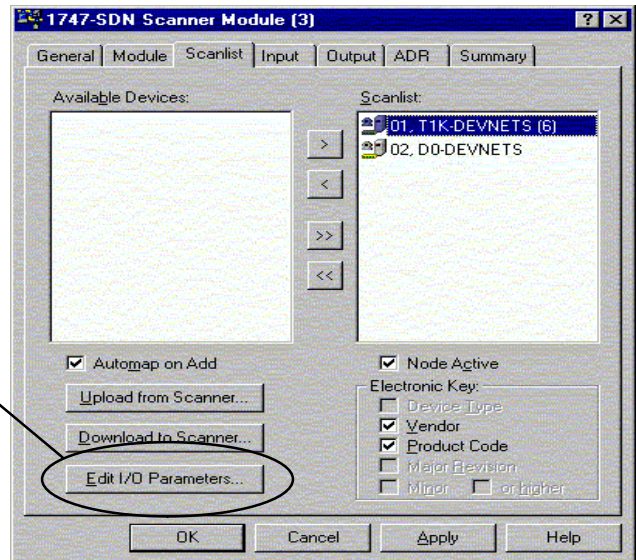

9. Set the **Rx Size** and the **Tx Size** to match the polled data size for the number of I/O bytes (refer to tables in Appendix C).

10. Click **OK**.

Refer to page E-18 (**Set Class Instance Attribute**) if the total number of Rx and Tx bytes are not known.

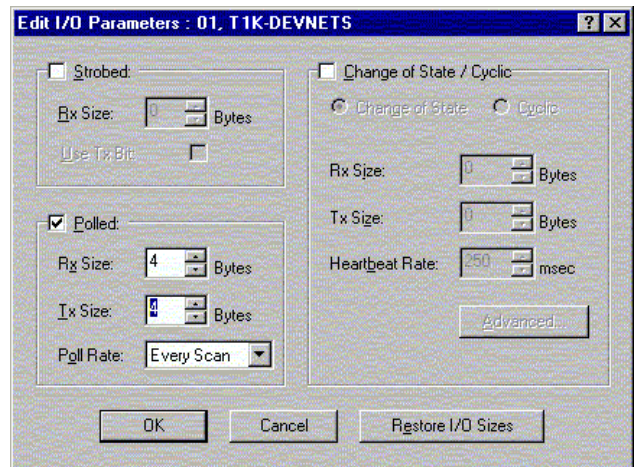

This window will appear.

11. Click **Yes**.

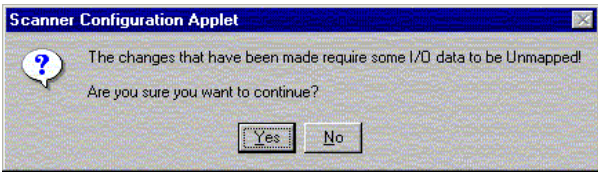

**Map the nodes**

Map each node.

1. Click the **Input** tab in the properties window.

Be sure that T1K-DEVNETS is selected.

2. Select **Discrete** for **Memory**, and **0** for **Start Word**.
3. Click **AutoMap**.

NOTE: M file is used with explicit messaging.

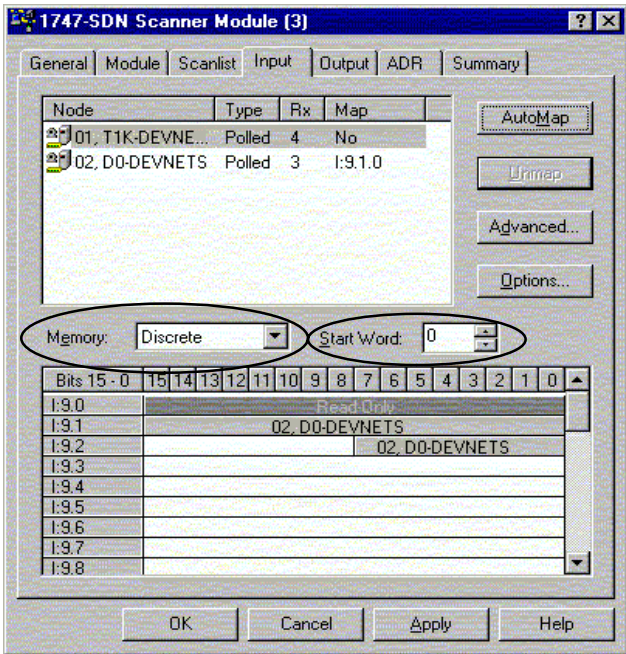

At the completion of the input AutoMapping, the window will look like this example. The T1K-DEVNETS node is now shown.

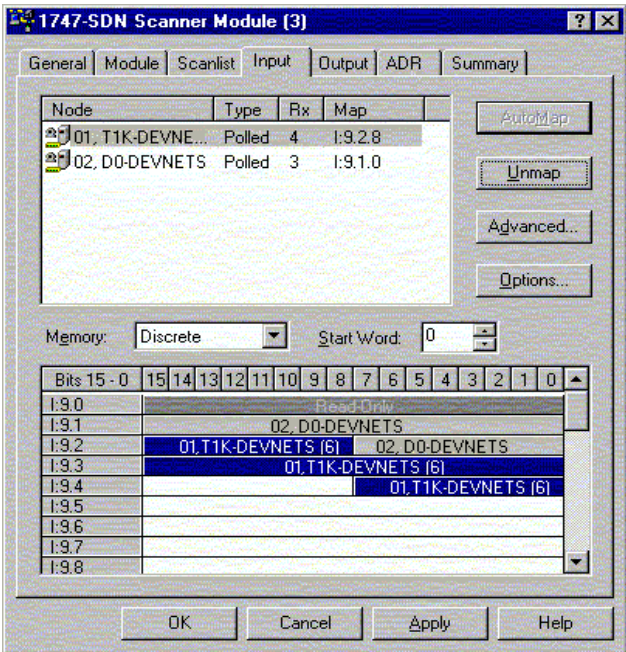

Now, map the outputs just the way you mapped the inputs. This time:

1. Click the **Output** tab in the properties window.

Be sure that T1K-DEVNETS is selected.

2. Select **Discrete** for **Memory**, and **0** for **Start Word**.
3. Click **AutoMap**.

At the completion of the output AutoMapping, the window will appear like this example. The T1K-DEVNETS node is now shown.

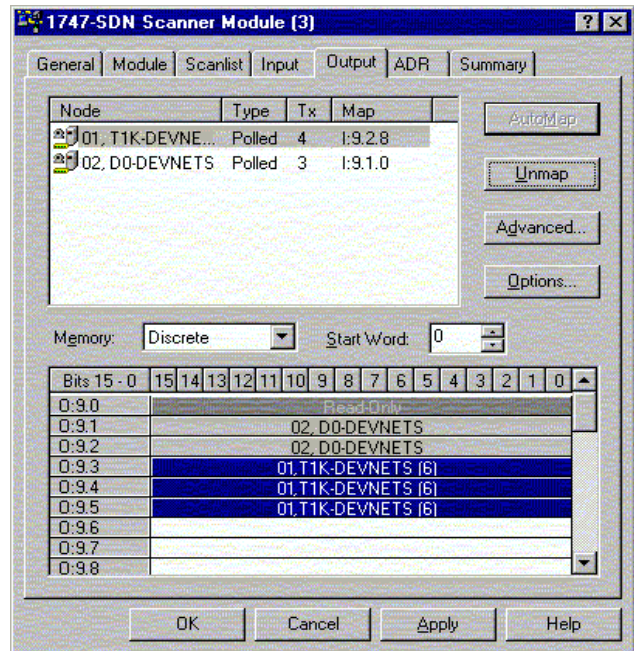
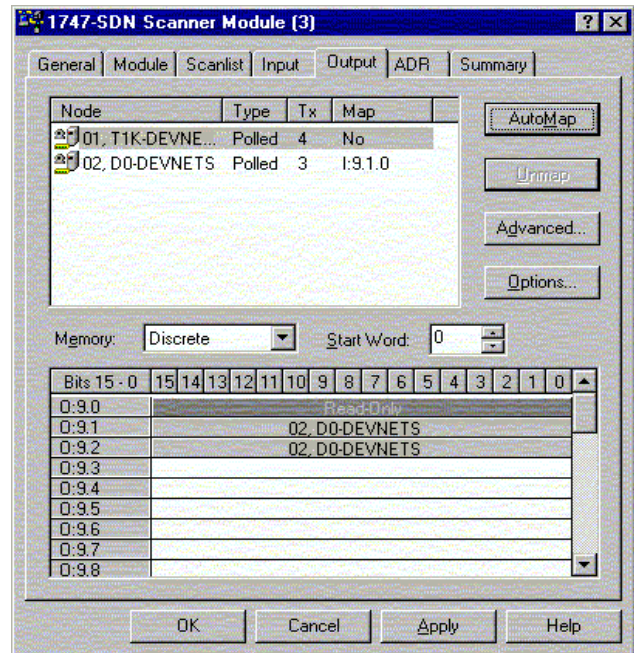

Download the scanlist to the scanner.

1. Select the **Scanlist** tab in the properties window.
2. Select **Download to Scanner**.

In the pop-up window:

3. Check **All Records**, then
4. Click **Download**.

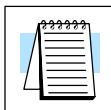
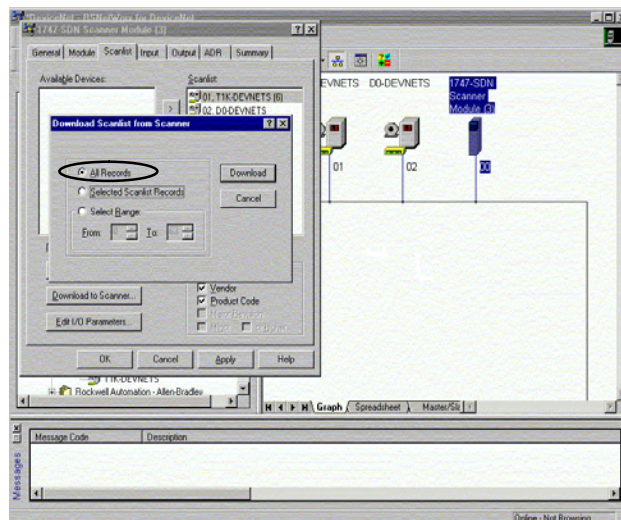

**Note:** Verify that the processor is in program mode before downloading the scanlist.

This is an error message that may appear.

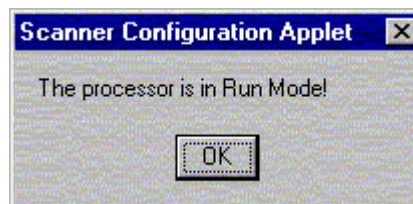

When the download indication ends, download is complete.

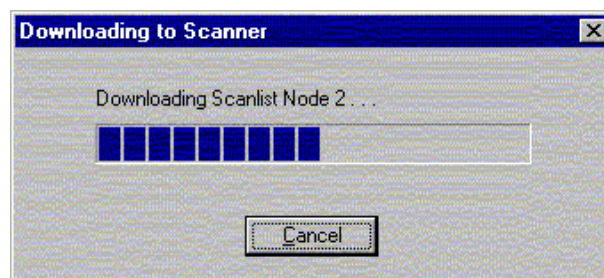

**Set Class Instance Attribute** Use the Service Class Instance Attribute Editor to set the I/O to read and write to the T1K –DEVNETS.

1. Select the T1K–DEVNETS node. Either click on **Device** or right click on the node symbol in the RSNetWorx window.
2. Select **Class Instance Editor** in the pop-up window.

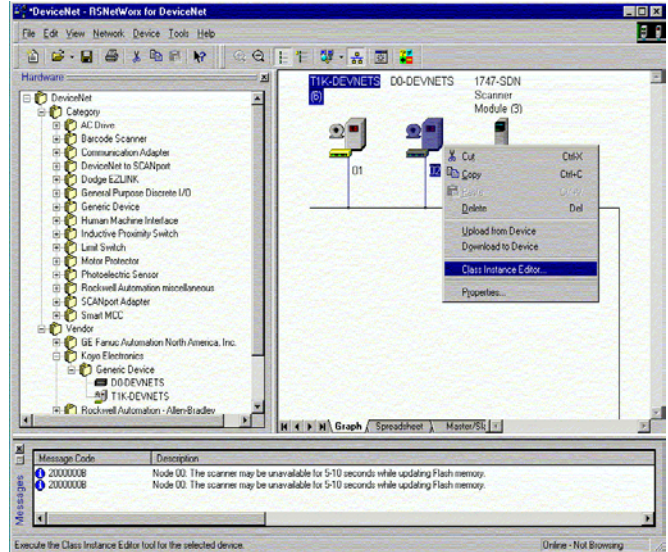

3. Setup input attributes in this window.

**Object Address** must be set to: **Class = 5, Instance = 2, Attribute = 7**

**Size = Word (2 bytes).**

4. Click on **Execute**.  
Read the data here.

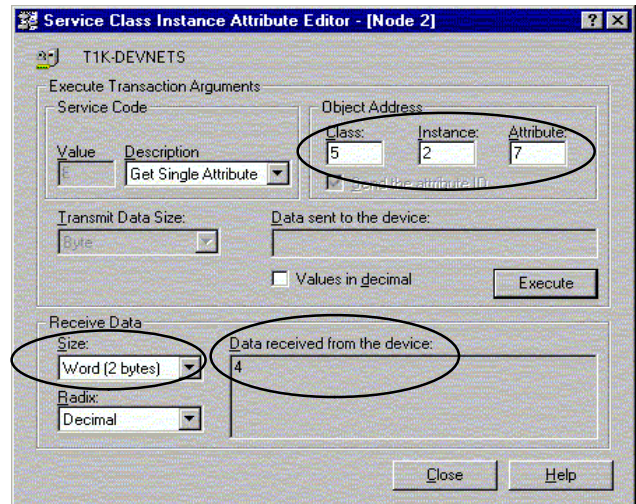

5. Setup output attributes in this window.

**Object Address** must be set to:

**Class = 5, Instance = 2, Attribute = 8**

**Size = Word (2 bytes).**

6. Click on **Execute**.  
Read the data here.

