

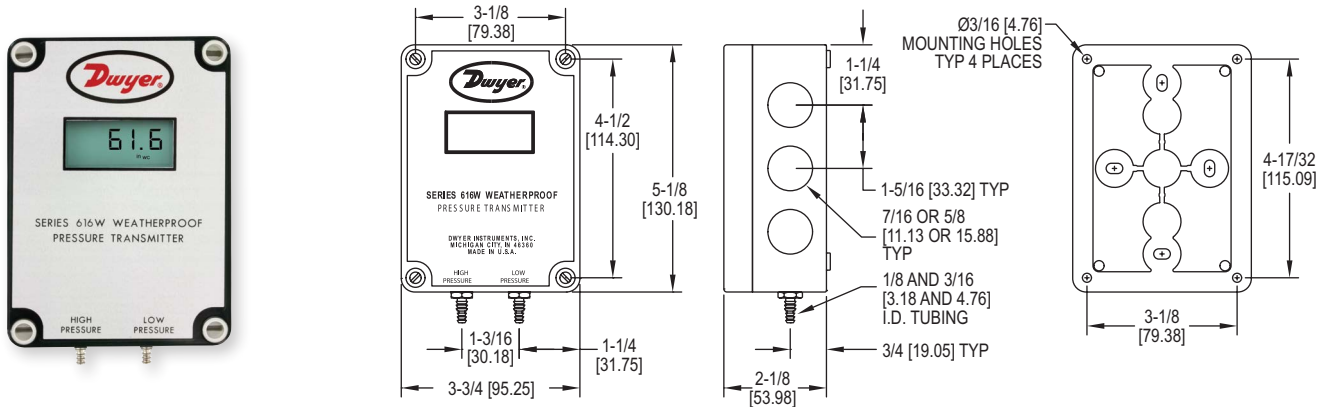

Series 616W Differential Pressure Transmitter

Specifications - Installation and Operating Instructions



The **Series 616W Differential Pressure Transmitter** senses the pressure of air and non-combustible, compatible gases and sends a standard 4 to 20 mA or selectable 0 to 5/0 to 10 VDC output signal. All models, including those featuring an LCD, are factory calibrated to specific ranges. Positive, negative, and differential pressures can be measured within a full scale accuracy of $\pm 0.25\%$. This weatherproof unit is enclosed in a polycarbonate case, rated IP66/NEMA 4X. The span and zero controls are for use when checking calibration, and are not intended for re-ranging.

SPECIFICATIONS

Service: Air and non-combustible, compatible gases.
Wetted Materials: Consult factory.
Accuracy: 0.25% FS @ 77°F (25°C), display accuracy $\pm 0.5\%$.
Thermal Effect: $\pm 0.02\%$ FS/°F ($\pm 0.036\%$ FS/°C).
Stability: $\pm 1\%$ FS/yr.
Temperature Limits: 14 to 185°F (-10 to 85°C).
Pressure Limits: See chart.
Power Requirements: 10 to 35 VDC (2-wire), 17 to 36 VDC, or isolated 21.6 to 33 VAC (3-wire).
Output Signal: 4 to 20 mA (2-wire), 0 to 5 VDC, or 0 to 10 VDC (3-wire)
Zero and Span Adjustments: Push buttons.
Loop Resistance: Current Output: 0 to 1250 Ω (max); Voltage Output: Load resistance 1 k Ω (min).
Current Consumption: 40 mA max.
Electrical Connections: 3-wire removable European style terminal block for 16 to 26 AWG.
Process Connections: Barbed, dual size to fit 1/8" and 3/16" (3.12 and 4.76 mm) I.D. rubber or vinyl tubing.
Enclosure Rating: NEMA 4X (IP66).
Mounting Orientation: Any orientation.
Weight: Without LCD: 8.8 oz (249 g); With LCD: 9.6 oz (272 g).
Agency Approvals: CE.

Series 616W Transmitter Models & Ranges

MODEL CHART			
Model	Range	Max. Pressure	Digital Display
616W-2	0 to 6 in w.c.	10 psig	—
616W-3	0 to 10 in w.c.	10 psig	—
616W-4	0 to 20 in w.c.	20 psig	—
616W-5	0 to 40 in w.c.	20 psig	—
616W-6	0 to 100 in w.c.	15 psig	—
616W-7	0 to 200 in w.c.	45 psig	—
616W-2-LCD	0 to 6 in w.c.	10 psig	0 to 6.00
616W-3-LCD	0 to 10 in w.c.	10 psig	0 to 10.00
616W-4-LCD	0 to 20 in w.c.	20 psig	0 to 20.0
616W-5-LCD	0 to 40 in w.c.	20 psig	0 to 40.0
616W-6-LCD	0 to 100 in w.c.	15 psig	0 to 100.0
616W-7-LCD	0 to 200 in w.c.	45 psig	0 to 200.0
616W-6B-LCD	3-0-3 in w.c.	10 psig	-3.00-0-3.00
616W-10B-LCD	5-0-5 in w.c.	10 psig	-5.00-0-5.00
616W-20B-LCD	10-0-10 in w.c.	10 psig	-10.00-0-10.00
616W-2M-LCD	0 to 1.5 kPa	68.9 kPa	0 to 1.50
616W-3M-LCD	0 to 2.5 kPa	68.9 kPa	0 to 2.50
616W-4M-LCD	0 to 5 kPa	137.8 kPa	0 to 5.00
616W-5M-LCD	0 to 10 kPa	137.8 kPa	0 to 10.0

Table 1

INSTALLATION

- Location:** Select a clean, dry mounting location free from excess vibration where the temperature will remain between 14 to 185°F (-10 to 85°C). Distance from the receiver is limited only by total loop resistance. See Electrical Connections below. The tubing supplying pressure to the instrument can be practically any length required, but long lengths will increase response time slightly.
- Position:** A vertical position, with the pressure connection pointing down, is recommended. That is the position in which all standard models are spanned and zeroed at the factory. They can be used at other angles, but final spanning and zeroing must be done while the transmitter is in that alternate position.
- Pressure Connections:** Two integral barbed tubing connections are provided. They are dual-sized to fit both 1/8" and 3/16" (3.12 and 4.76 mm) I.D. tubing. Be sure the pressure rating of the tubing exceeds that of the operating range. On ranges over 20 psi, we recommend use of a suitable hose clamp to assure the integrity of the connection.

ELECTRICAL CONNECTIONS

CAUTION Do not exceed specified supply voltage ratings. Permanent damage not covered by warranty will result. This unit is not designed for 120 or 240 VAC line operation.

Electrical connections are made to the terminal block located on the inside of the transmitter. Determine which of the following circuit drawings best applies to your application and wire accordingly.

Electrical Connection

The Series 616W simultaneously transmits a 2-wire 4 to 20 mA current output and a 3-wire 0 to 5 V / 0 to 10 V voltage output via a removable European-style three conductor terminal block. The transmitter can be wired in one of the following three ways to utilize the current and/or voltage output.

Power Supply

Refer to Table 2 for the required supply rating.

MODEL CHART	
Output Type	Power Supply Rating
2-wire current	10 to 35 VDC (40 mA min)
3-wire current	17 to 36 VDC or 21.6 to 33 VAC (40 mA min)
Simultaneous current and voltage	17 to 35 VDC (40 mA min)

Table 2

Choose a power supply with a voltage and current rating sufficient to meet the power specifications under all operating conditions. If the supply is unregulated, make sure that the output voltage remains within the required voltage range under all power line conditions. Ripple on the supply should not exceed 100 mV.

AC/DC Jumper Selection

NOTICE The jumper is factory set to AC. If DC power is applied while the jumper is set to AC, no damage will occur. However, the accuracy of the unit may be temporarily affected.

CAUTION Powering the unit with AC power while the jumper is set to DC may permanently damage the transmitter.

Refer to Figure 1 for the location of the AC/DC jumper. Place the shorting jumper across either the two pins marked AC or the two pins marked DC.

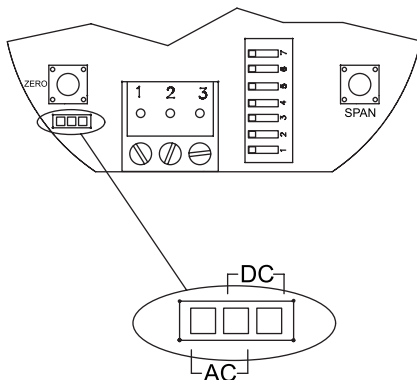

Figure 1: AC/DC Jumper

2-Wire 4 to 20 mA Current Operation

CAUTION Do not exceed specified supply voltage ratings. Permanent damage not covered by warranty will result. Simultaneous outputs are not designed for AC voltage operation.

The connections to the transmitter are made through terminals 2 and 3 on the terminal block as shown in Figure 2. The terminal block is removable and each of the terminals are labeled underneath the terminal block on the circuit board. Polarity is indicated by terminals 2 (+IOUT) and 3 (-IOUT). The AC/DC selection jumper should be set for DC operation.

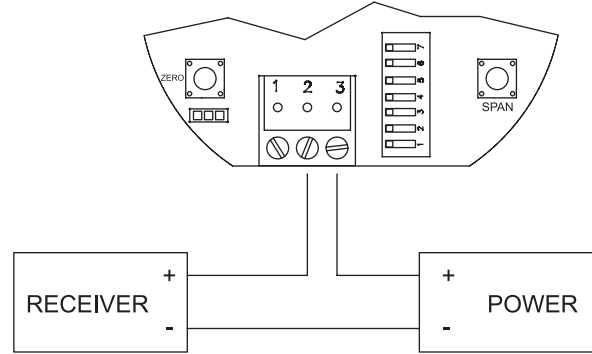

Figure 2: Current Output Wiring

The range of appropriate receiver load resistances (R_L) for power supply voltage available is given by the formula listed below. Shielded 2-wire cable is recommended for control loop wiring. Ground the shield at the power supply end.

NOTICE The receiver may be connected to either the negative or positive side of the loop, whichever is most convenient. Should the polarity of the transmitter or receiver be inadvertently reversed, the loop will not function properly, but no damage will be done to the transmitter.

$$R_L = \frac{V_{PS} - 10.0}{20 \text{ mA DC}}$$

The maximum length of connecting wire between the transmitter and the receiver is a function of wire size and receiver resistance. That portion of the total current loop resistance represented by the resistance of the connecting wires themselves should not exceed 10% of the receiver resistance. For extremely long runs (over 1,000 ft/305 m), it is desirable to select receivers with lower resistances in order to keep the size and cost of the connecting leads as low as possible. In installations where the connecting run is no more than 100 ft (30.5 m), connecting lead wire as small as No. 22 ga. can be used.

3-Wire 0 to 10 V and 0 to 5 V Voltage Operation

CAUTION Do not exceed specified supply voltage ratings. Permanent damage not covered by warranty will result.

The connections to the transmitter are made to Terminals 1, 2, and 3 on the terminal block as shown in Figure 3. The terminal block is removable and each of the terminals are labeled underneath the terminal block on the circuit board. Polarity is indicated by 1, 2, and 3. When connecting using a DC power source, make sure the AC/DC selection jumper is set for DC. If the polarity of the transmitter is inadvertently reversed, the unit will not function properly, but no damage will be done to the transmitter. When connecting to an AC power source, make sure the AC/DC selection jumper is set for AC. Either lead of the supply power may be connected to terminals 1 and 2 without affecting the operation of the transmitter or causing damage to the transmitter.

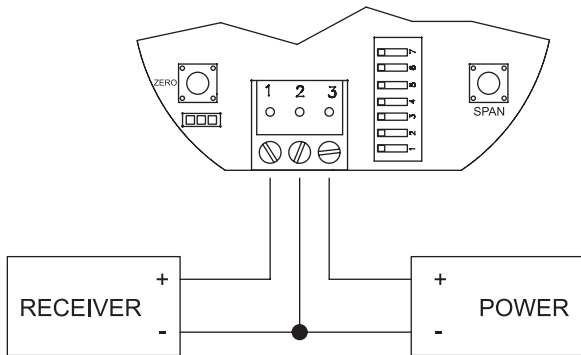

Figure 3: Voltage Output Wiring

The minimum receiver load is 1 kΩ. The resistance due to the wire should be low compared to the receiver load resistance. While the voltage at the terminal block remains unchanged with a 10 mA current flow, resistive losses in the wiring do cause errors in the voltage delivered to the receiver. For a 1% accuracy gauge, the resistance of the wires should be less than 0.1% of the value of the receiver load resistance. This will keep the error caused by the current flow below 0.1%.

Simultaneous Current and Voltage Operation

CAUTION Do not exceed specified supply voltage ratings. Permanent damage not covered by warranty will result. Simultaneous outputs are not designed for AC voltage operation.

The connections to the transmitter are made to Terminals 1, 2, and 3 on the terminal block as shown in Figure 4. The terminal block is removable and each of the terminals are labeled underneath the terminal block on the circuit board. Polarity is indicated by terminals 1, 2, and 3. The AC/DC selection jumper should be set for DC operation. The voltage output and the power supply must have separate wire leads that are only joined at terminal 2 of the transmitter. Additional error may occur for the voltage output if a single wire is used or if the wires are joined at the power supply or receiver.

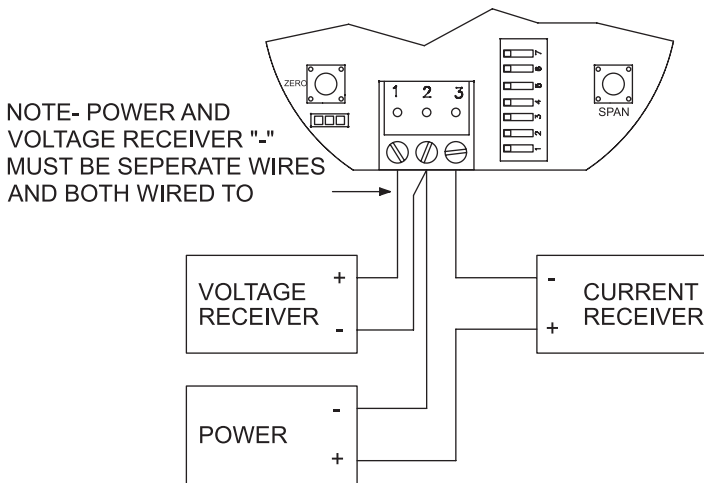

Figure 4: Simultaneous Current and Voltage Output Wiring

For the current output, the maximum allowable loop resistance (wiring + receiver resistance) is dependent on the power supply. The maximum loop voltage drop must not reduce the transmitter voltage below 17 V. The maximum loop resistance can be calculated using the following equation:

$$R_{MAX} = \frac{V_{PS} - 17.0}{20 \text{ mA DC}}$$

(where V_{PS} is the power supply voltage)

The equation uses 17.0 instead of 10.0 used in the current only equation. This represents the minimum voltage supply which is higher on the simultaneous output configuration due to the requirements of the voltage outputs.

Shielded 4-wire cable is recommended for control loop wiring. Ground the shield at the power supply end only. Should the polarity of the transmitter or receiver be inadvertently reversed, the unit will not function properly, but no damage will be done to the transmitter.

For voltage outputs, the minimum receiver load is 1 kΩ. The resistance due to the wire should be low compared to the receiver load resistance. While the voltage at the terminal block remains unchanged with a 10 mA current flow, resistive losses in the wiring do cause errors in the voltage delivered to the receiver. For a 1% accuracy gauge, the resistance of the wires should be less than 0.1% of the value of the receiver load resistance. This will keep the error caused by the current flow below 0.1%.

CALIBRATION

NOTICE There is a 5 second delay from the time the zero or span calibration button is released until the time that the change in the calibration takes place. This delay is used to prevent stress related offsets on the lower range.

Zero Calibration

The zero calibration can be set by applying zero pressure to both the pressure ports and pressing the zero button for 3 seconds. If either the remote or local LCD is present, the display will read ZERo and then sequence back to the home display.

Span Calibration

The span calibration can be adjusted only after setting the zero adjustment. It must be completed within 5 minutes of the last zero calibration. The span calibration button will be ignored until the zero calibration is completed. Apply pressure to the ports of the transmitter that are associated with the maximum output of the transmitter (20 mA, 5 V, or 10 V, depending on the output being used). Press and hold the span button for 3 seconds. If either the remote or local LCD are present, the display will read SPAN and then sequence back to the home display. If the span calibration is attempted before adjusting the zero calibration, the FAiL error message will flash on the display. On bi-directional models, separate spans can be performed on the positive and negative sides of the range.

ZERO DEADBAND

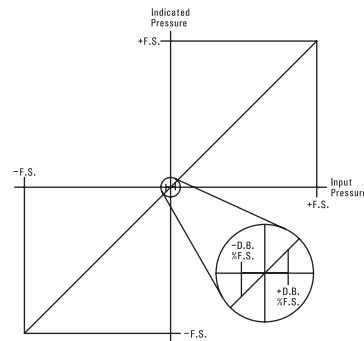

Figure 5

MAINTENANCE/REPAIR

Upon final installation of the Series 616W Differential Pressure Transmitter, no routine maintenance is required. The Series 616W is not field serviceable and is not possible to repair the unit. Field repair should not be attempted and may void warranty.



This symbol indicates waste electrical products should not be disposed of with household waste. Please recycle where facilities exist. Check with your Local Authority or retailer for recycling advice.

WARRANTY/RETURN

Refer to "Terms and Conditions of Sale" in our catalog and on our website. Contact customer service to receive a Return Goods Authorization number before shipping the product back for repair. Be sure to include a brief description of the problem plus any additional application notes.

