

Series One™ Programmable Controllers

Series One/One Plus
User's Manual

GE Fanuc Automation

August 1988

GEK-90842C

WARNINGS, CAUTIONS, AND NOTES AS USED IN THIS PUBLICATION

WARNING

Warning notices are used in this publication to emphasize that hazardous voltages, currents, temperatures, or other conditions that could cause personal injury exist in this equipment or may be associated with its use.

In situations where inattention could cause either personal injury or damage to equipment, a Warning notice is used.

CAUTION

Caution notices are used where equipment might be damaged if care is not taken.

NOTE

Notes merely call attention to information that is especially significant to understanding and operating the equipment.

This document is based on information available at the time of its publication. While efforts have been made to be accurate, the information contained herein does not purport to cover all details or variations in hardware and software, nor to provide for every possible contingency in connection with installation, operation, and maintenance. Features may be described herein which are not present in all hardware and software systems. GE Fanuc Automation assumes no obligation of notice to holders of this document with respect to changes subsequently made.

GE Fanuc Automation makes no representation or warranty, expressed, implied, or statutory with respect to, and assumes no responsibility for the accuracy, completeness, sufficiency, or usefulness of the information contained herein. No warranties of merchantability of fitness for purpose shall apply.

GEK-90842

The purpose of this manual is to provide information for the user to install, program and implement the family of Series One™ family of Programmable Controllers (PCs) into a control system. The Series One family of PCs includes the Series One, Series One Model E, Series One Plus and Series One Plus 3.7K PCs, which are described in this manual. The Series One Junior PC is described in a separate User's Manual, GEK-90503.

The Series One PC provides the user with the capability of developing and programming a control system using the familiar ladder diagram logic approach. The Series One Plus includes the same ladder diagram function plus a group of data operation functions, which includes data moves, math functions, conversion, and fault diagnosis.

Chapter 1, Introduction, is an introduction to the Series One and Series One Plus PCs, with emphasis on features and capabilities. A summary of terms common to PCs is provided at the end of this chapter as an aid to first-time PC users.

Chapter 2, Physical Equipment Configuration, provides a detailed description of the hardware components of the PC. This chapter provides an understanding of the components of a Series One or Series One Plus PC system and how they are related to the overall system.

Chapter 3, Installation, provides the specifications and instructions required for installation of your Programmable Control system.

Chapter 4, PC Operation, describes the operation of the Series One and Series One Plus PCs, including features and functions of the programmer used for entering new programs, editing existing programs, monitoring the status of inputs or outputs, displaying timer or counter accumulated values, and displaying register contents. The last part of this chapter describes operation of peripheral devices which may be used with both Programmable Controllers. Peripherals include an audio cassette tape recorder for recording your program after it has been entered in order to have a permanent record of that program, a PROM Writer Unit, which allows a non-volatile means of program storage within the PC, and a Printer Interface Unit to allow documenting of your programs.

Chapter 5, Programming, provides the basic information required in order to develop, enter, and implement your programs. A description of each function is provided, including examples of using each function. Three sections are included: Programming, Basic Instructions, and Data Operation Instructions.

Chapter 6, I/O Specifications and Wiring, is a guide to the specifications of the input and output (I/O) modules and their physical connections to field devices.

Chapter 7, Maintenance, is a guide to basic maintenance of your system, should it be needed. Reliability of the Series One family of PCs is excellent and other than changing the Lithium back-up battery, when required, there should be little maintenance required of your PC. This chapter includes troubleshooting procedures and information on replacing components.

Chapter 8, Applications, provides several typical Applications using the capabilities of the Series One and Series One Plus PCs. This chapter should be especially helpful to first-time users of a programmable controller.

Appendices A through D contain a summary of Related Documentation, a Glossary of Programmable Controller Terms, a guide to the compatibility of the Series One family of Programmable Controllers, and a Description of other GE Fanuc Automation North America, Inc. Programmable Controllers. A comprehensive index is included as an aid to the location in the manual of particular items of interest.

All references to Series One in this manual for hardware and programming apply to both the Series One and Series One Model E PCs, except where specifically noted in the text. Similarly, all references to Series One Plus apply to both the Series One Plus and Series One Plus 3.7K PCs.

Should further information be required, contact your salesperson or GE Fanuc Automation North America, Inc., P. O. Box 8106, Charlottesville, Virginia 22906.

First Edition - May 1986
Second Edition - March 1987
Third Edition - September 1987

Henry A. Konat
Senior Technical Writer

NOTE

The Series One/Series One Plus and associated modules have been tested and found to meet or exceed the requirements of FCC Rule, Part 15, Subpart J. The following note is required to be published by the FCC.

This equipment generates, uses, and can radiate radio frequency energy and if not installed and used in accordance with the instruction manual, may cause interference to radio communications. It has been tested and found to comply with the limits of a Class A computing device pursuant to Subpart J of Part 15 of FCC Rules, which are designed to provide reasonable protection against such interference when operated in a commercial environment. Operation of this equipment in a residential area is likely to cause interference, in which case the user at his own expense will be required to take whatever measures may be required to correct the interference.

 GEK-90842

CHAPTER 1.	SERIES ONE/SERIES ONE PLUS PC INTRODUCTION	
	History of Programmable Controllers	1-1
	Advantages Over Other Control Devices	1-1
	Series One Programmable Controllers	1-1
	Series One Model E Programmable Controller	1-3
	Series One Plus 3.7K	1-3
	Programmable Controller Concepts	1-5
	Programming the Series One and Series One Plus PCs	1-5
	Function of the Central Processing Unit	1-6
	Memory Word Length	1-6
	Types of Memory for Program Storage	1-7
	Function of the Input/Output Circuitry	1-7
	Communicating With Other Devices	1-8
	Remote I/O for Series One and Series One Plus	1-8
	PC Terminology	1-8
CHAPTER 2.	PHYSICAL EQUIPMENT CONFIGURATION	
	Rack Description	2-1
	Module Location in Rack	2-1
	Heat Dissipation	2-2
	Adding Racks	2-2
	Programmer Tape Port	2-4
	Programmer Mount Assembly	2-4
	Hardware Requirements	2-7
	System Estimating	2-7
	Peripheral Devices Supporting Series One Family of PCs	2-9
	Data Communications Unit	2-10
	Printer Interface Unit	2-11
	PROM Writer Unit	2-12
CHAPTER 3.	INSTALLATION	
	Specifications for Installation	3-1
	Installation	3-2
	Power Supply Limitations for Racks	3-13
	Units of Load	3-13
	Safety Considerations	3-15
	Recommended Field Wiring Procedures	3-15
CHAPTER 4.	PC OPERATION	
	Introduction to PC Operation	4-1
	Programmer	4-1
	Programmer Features	4-2
	Mode Switch	4-2
	Address Data Display	4-2
	Status Display	4-2
	Logic Display	4-2
	Logic Keys	4-3
	Editing Keys	4-4

Shifted Functions	4-5
Data Operation Keys	4-6
Peripheral Jack	4-7
Program Checking and Error Codes	4-7
Operation Sequences	4-8
Monitor CPU Logic	4-10
Search CPU Logic	4-11
Alter One Logic Element	4-11
Delete One Logic Element	4-12
Clear All Memory	4-12
Insert One Logic Element	4-12
Monitor I/O Status	4-12
Monitor Timer or Counter Status	4-13
Display a Specific Address	4-13
Monitor Data Register Contents	4-14
Change Contents of a Data Register	4-14
Enter or Change a Password	4-14
Access to Programmer Functions with Password in Effect	4-14
Forcing References	4-15
Operation With Peripheral Devices	4-15
Tape Recorder Operation	4-15
Recording A Program	4-16
Verifying A Program	4-16
Loading A Program	4-18
Printer Interface Unit	4-18
Hardware Description	4-19
Hardware Features	4-20
80/132 Column Selection Switch	4-21
External Power Supply Connector	4-21
Power Supply Select Switch	4-21
Sequence of Operation	4-22
Power-up Sequence	4-22
User Program Transfer From PC To Printer Interface Unit	4-22
Selection of Printout Format and Type of PC	4-22
Start Printer Operation	4-22
Printing Of Error Messages During Ladder Diagram Listing	4-23
Printing Of Error Messages During Boolean Listing	4-23
Cross Reference Printout	4-23
Expanded Print Format	4-24
Printout Annotation Explanation	4-24
Sample Printout	4-25
PROM Writer Unit	4-29
Front Panel Features	4-30
Sequence of Operation	4-31
External Power Supply Connector	4-31
Power Supply Select Switch	4-31

GEK-90842

	Timer/Counter Setpoint Unit	4-32
	Timer/Counter Setpoint Unit Specifications	4-33
	Remote Mounting of Timer/Counter Setpoint Unit	4-33
	References for the Timer/Counter Setpoint Unit	4-33
	Example of Using Thumbwheel Inputs	4-34
CHAPTER 5.	PROGRAMMING	
Section 1.	Introduction to Programming	5-1
	General Information	5-1
	Planning a PC System	5-1
	How to Use This Chapter	5-1
	Programming Fundamentals	5-7
	Significance of References	5-7
	Significance of Input/Output References	5-8
	Internal Coils	5-13
	Use of the Special Function Coils	5-13
	Shift Register References	5-13
	Timer and Counter References	5-13
	Data Registers	5-13
	Flexibility in Using References	5-14
	Operating Principles	5-14
	Scanning	5-14
	Programmer Functions	5-15
	Basic Ladder Diagram Format	5-17
	Concept of Power Flow	5-17
	Unlimited References	5-18
Section 2.	Basic Instructions	5-19
	Basic Instructions	5-19
	How to Begin Programming	5-19
	Entering a Rung With Series Contacts	5-19
	Entering the Clear all Memory Sequence	5-19
	Entering a Rung with Parallel Contacts	5-20
	Entering a Simple Timer Rung	5-20
	Basic Relay Logic (Motor Starter)	5-20
	Motor Starter Logic Description	5-21
	Normally Closed Input	5-22
	Push-Down Stack	5-23
	Detailed Example of AND STR, OR STR	5-24
	Description of Operation	5-24
	Use of Retentive Coils as Latches	5-26
	Programming a Latched Relay	5-26
	Master Control Relay Functional Description	5-27
	Programming a Master Control Relay Function	5-28
	Multiple Master Control Relay Functions	5-28
	Disabling of Outputs	5-29
	Timer and Counter Functional Description	5-30
	Special Timer/Counter References	5-30
	Programming Timers	5-30
	Specifying Timer Preset Values	5-31
	Programming Counters	5-32

	Extending the Timer and Counter Range	5-34
	Sequencer Operation	5-36
	Referencing Sequencer Contacts with a Series One Plus PC	5-37
	Shift Register Functional Description	5-38
	Shift Register References	5-39
	Shift Register Operation	5-40
	Forcing I/O References	5-42
Section 3.	Data Operation Instructions for the Series One Plus Programmable Controller	5-43
	Data Operations	5-43
	Using References for Data Operations	5-44
	Entering a Constant Value	5-44
	Entering a Group Reference	5-44
	Data Register References	5-44
	Timer/Counter References	5-45
	Example of Specifying a Group Reference	5-45
	Programming the Data Operation Instructions	5-45
	Special Function Coils for Data Operations	5-46
	D•STR (F50)	5-47
	D•STR1 (F51)	5-48
	D•STR2 (F52)	5-48
	D•STR3 (F53)	5-49
	D•STR5 (F55)	5-49
	D•OUT (F60)	5-50
	D•OUT1 (F61)	5-50
	D•OUT2 (F62)	5-51
	D•OUT3 (F63)	5-51
	D•OUT5 (F65)	5-52
	CMPR (F70)	5-52
	Addition (+), BCD 4 Digit (F71)	5-53
	Subtraction (-), BCD 4 Digit (F72)	5-56
	Multiplication (X), BCD 4 Digit (F73)	5-58
	Division (:), BCD 4 Digit (F74)	5-59
	D•AND (DATA AND) (F75)	5-61
	D•OR (DATA OR) (F76)	5-63
	Shift Right (F80)	5-65
	Shift Left (F81)	5-65
	Decode (F82)	5-67
	Encode (F83)	5-68
	INV (F84)	5-68
	BIN (BCD to Binary) (F85)	5-69
	BCD (Binary to BCD) (F86)	5-70
	External Fault Diagnosis (F20)	5-71
CHAPTER 6.	I/O SPECIFICATIONS AND WIRING	
	I/O System Introduction	6-1
	Field Wiring to I/O Modules	6-2
	16 Circuit I/O Modules with Connectors	6-4
	I/O References for 16 Circuit Modules	6-4

GEK-90842

I/O Interface Cable Cross Reference List	6-5
I/O Module Catalog Numbers	6-6
I/O Module Specifications and Wiring	6-7
115 V ac Input IC610MDL125	6-7
230 V ac Input IC610MDL127	6-8
115 V ac Isolated Input IC610MDL126	6-9
24 V dc Sink Input (8 Circuits) IC610MDL101	6-10
24 V dc Sink Input (16 Circuits) IC610MDL106	6-11
24 V dc Sink Load Input (16 Circuits) with Removable Terminal Board IC610MDL107	6-12
24 V ac/dc Source Input IC610MDL111	6-13
24 V ac/dc Source Input (16 Circuits) with Removable Terminal Board IC610MDL112	6-14
115/230 V ac Output IC610MDL175	6-16
115/230 V ac Isolated Output IC610MDL176	6-17
24 V dc Sink Output (8 Circuits) IC610MDL151	6-18
24 V dc Sink Output (16 Circuits) IC610MDL156	6-19
24 V dc Sink Output (16 Circuits) with Removable Terminal Board IC610MDL157	6-20
24 V dc 2 Amp Sink Output IC610MDL153	6-22
24 V dc 2 Amp Sink/Source Output IC610MDL154	6-23
24 V dc Source Output IC610MDL155	6-24
24 V dc Source Output (16 Circuits) with Removable Terminal Board IC610MDL158	6-26
Relay Output (8 Circuits) IC610MDL180	6-27
Relay Output (16 Circuits) with Removable Terminal Board IC610MDL182	6-29
24 V dc Input/Output (4 In/4 Out) IC610MDL103	6-31
24 V dc Input/Relay Output (4 In/4 Out) IC610MDL104	6-33
Thumbwheel Interface IC610MDL105	6-36
High Speed Counter IC610MDL110	6-39
Module Location	6-41
Interface to Field Devices	6-42
Up/Down Counter Inputs	6-43
Encoder Interface 1	6-44
Binary Coded Decimal (BCD) Output	6-46
Counter Output	6-48
Interface to User Logic	6-49
Interface Function Definition	6-50
Output Logic	6-53
Manual Mode	6-53
Counter Mode	6-53
Filter Selection	6-55
Fast Response I/O IC610MDL115	6-56
Mode Selection	6-58
Output Logic - Manual Mode	6-58
Output Logic - Fast Response Mode	6-58
I/O Simulator IC610MDL124	6-61
Analog Input IC610MDL116	6-62

	Introduction	6-62
	Hardware Features	6-62
	Power Requirements	6-62
	General and Electrical Specifications	6-62
	I/O Reference Definitions	6-63
	Sample Ladder Logic	6-64
	Analog Input Module Features	6-66
	Selection Of Operating Mode	6-66
	Analog OutputIC610MDL166	6-67
	Introduction	6-67
	Hardware Features	6-67
	Power Requirements	6-67
	General and Electrical Specifications	6-67
	I/O Reference Definitions	6-68
	Sample Ladder Logic	6-69
	Analog Output Module Features	6-70
	UL Listed Products	6-71
	5-Slot Rack, UL ListedIC610CHS111	6-72
	115 V ac Input Module, UL ListedIC610MDL135	6-73
	Relay Output Module, UL ListedIC610MDL181	6-74
	115 V ac Output Module, UL ListedIC610MDL185	6-75
	115 V ac Input Module (16 Circuits) with Removable Terminal Board IC610MDL129	6-76
	115/230 V ac Output Module (8 Circuits) with Removable Terminal Board IC610MDL179	6-77
CHAPTER 7.	MAINTENANCE	
	Introduction to Maintenance Procedures	7-1
	Troubleshooting Aids	7-1
	Basic Troubleshooting Procedure	7-1
	General Troubleshooting Procedure	7-2
	Replacement of Components	7-3
	Replacing a Rack	7-3
	Replacing a CPU Module	7-3
	Replacing I/O Modules	7-4
	Replacing the Battery	7-4
	Adding Memory	7-5
	Spare Parts and Components	7-6
	Fuse List	7-7
CHAPTER 8.	APPLICATIONS	
	Application 1 - One-Shots	8-1
	Application 2 - Flip Flop	8-2
	Application 3 - Event/Time Drum	8-3
	Application 4 - Cascaded Counters	8-5
	Application 5 - Coil 374, Power-Up One-Shot	8-7
	Description of Operation	8-7
	Application 6 - Coil 375, 10Hz Clock	8-8
	Example 1: - Cumulative Timer	8-8
	Example 2: - Time of Day Clock	8-8
	Application 7 - Start/Stop Circuit	8-11

 GEK-90842

	Application 8 - High Speed Counter Applications	8-12
	Programmable Cam Switch	8-13
	Cut to Length	8-16
	Measuring a Random Length	8-18
	Sample Calculation	8-18
	Application 9 - Typical Shift Registers	8-21
	Shift Register References	8-21
APPENDIX A.	Related Documentation	A-1
	Introduction	A-1
	GEK-90477 Series One/Three Data Communications Manual	A-1
	GEK-90507 Remote I/O User's Manual	A-1
	GEK-90825 Series Six PC I/O Link Local Module User's Manual	A-2
	GEK-90846 Portable Programmer User's Manual	A-2
	GEK-96662 Logicmaster 1 Programmer Documentor Manual	A-3
	GFK-0075 Logicmaster 1 Family Programming and Documentation Software User's Manual	A-4
APPENDIX B.	Glossary of Terms	B-1
APPENDIX C.	Series One Family of Programmable Controllers Compatibility Guide	C-1
APPENDIX D.	Other Programmable Controllers	D-1
	Series One™ Junior Programmable Controller	D-1
	Series Three™ Programmable Controller	D-2
	Available I/O Types	D-2
	Series Six™ Programmable Controller	D-3
	Programming	D-3
	Optional Items	D-4
	Series Six™ Plus Programmable Controller	D-4

GEK-90842

Figure			
	1-1	Series One/Series One Plus Programmable Controllers	1-2
	1-2	Basic PC Block Diagram	1-5
	2-1	Typical Rack	2-1
	2-2	Typical Hardware	2-2
	2-3	Typical (5 Slot) Rack	2-3
	2-4	Typical (10 Slot) Rack	2-3
	2-5	Expander Cable Installation	2-4
	2-6	Programmer Mount Assembly	2-5
	2-7	Example of Relay Control	2-9
	2-8	Data Communications Unit	2-10
	2-9	Printer Interface Unit	2-11
	2-10	Prom Writer Unit	2-12
	3-1	Rack Mounting Dimensions for Proper Heat Dissipation	3-2
	3-2	Recommended Rack Grounding	3-3
	3-3	10 Slot Rack, 19 Inch Mounting Dimensions	3-4
	3-4	I/O Expansion Cable Connection	3-4
	3-5	I/O Addressing Switches in Series One Plus 10 Slot Racks	3-5
	3-6	Examples of Rack Configuration Switch Setting Series One Plus	3-6
	3-7	Typical Installation Dimensions	3-7
	3-8	CPU Module	3-8
	3-9	Proper Module Insertion	3-9
	3-10	Proper Module Removal	3-9
	3-11	Typical Routing of I/O Wiring	3-11
	3-12	Pull Tab on Programmer Cable	3-12
	3-13	Installation of Programmer Cable	3-12
	3-14	Programmer Mount Assembly	3-13
	4-1	Programmer Features	4-1
	4-2	Series Logic (AND)	4-3
	4-3	Parallel Logic (OR)	4-3
	4-4	Volume Control Range Setting	4-17
	4-5	Printer Interface Unit	4-20
	4-6	Sample Ladder Diagram Printout	4-25
	4-7	Sample Boolean Printout	4-26
	4-8	Sample Outputs Used Table Printout	4-27
	4-9	Sample Outputs Used Table Printout (continued)	4-28
	4-10	PROM Writer Unit Features	4-29
	4-11	Timer/Counter Setpoint Unit	4-32
	5-1	I/O References Per Physical Placement for 5 and 10-Slot Racks	5-9
	5-2	CPU Scanning Sequence	5-15
	5-3	Programmer for Series One and Series One Plus	5-16
	5-4	Typical Ladder Diagram	5-17
	5-5	Sample Relay Logic (Motor Starter)	5-21
	5-6	Example of Normally Closed Inputs	5-22
	5-7	AND STR and OR STR Connections	5-23
	5-8	Push-Down Stack Storage Locations	5-24
	5-9	Push-Down Stack Logical Operations	5-24
	5-10	AND STR/OR STR Example Number 1	5-25

5-11	AND STR/OR STR Example Number 2	5-26
5-12	Example of Latching Logic	5-27
5-13	Example of Master Control Relay Logic	5-28
5-14	Multiple Master Control Relay Logic	5-29
5-15	Sample Coil Disabler Logic	5-30
5-16	Sample of Timer Logic	5-31
5-17	Example of Timer Logic	5-32
5-18	Example of Counter Logic	5-33
5-19	Example of Counters	5-34
5-20	Example of Extended Counters	5-35
5-21	Illustration of Sequencer Operation	5-36
5-22	Example of Sequencer	5-37
5-23	Typical Sequencer Logic	5-38
5-24	Typical Shift Register	5-39
5-25	Example of Shift Register	5-40
5-26	Example of Shift Register Logic	5-41
5-27	Data Operation Block Diagram	5-43
6-1	A. Typical I/O Module B. High Density Module With Removable Connector	6-3
6-2	Typical I/O Terminal Configuration	6-3
6-3	I/O Interface Cable Wiring List	6-4
6-4	Example of 16 Circuit I/O References	6-5
6-5	Wiring for 115 V ac Inputs	6-7
6-6	Wiring for 230 V ac Inputs	6-8
6-7	Wiring for 115 V ac Isolated Inputs	6-9
6-8	Wiring for 24 V ac Sink Inputs	6-10
6-9	I/O Points VS Temperature	6-11
6-10	Wiring for 16 CIRCUIT, 25 V dc Sink Input Module	6-11
6-11	I/O Points VS Temperature	6-12
6-12	Wiring for 16 Circuit, 24 V dc Sink Load Inputs	6-12
6-13	Wiring for 24 V ac/dc Inputs	6-13
6-14	I/O Points vs Temperature Chart	6-14
6-15	Wiring for 16 Circuit 24 V ac/dc Source Load Inputs	6-15
6-16	I/O Points vs Temperature	6-16
6-17	Wiring for 115/230 V ac Outputs	6-16
6-18	I/O Points vs Temperature Chart	6-17
6-19	Wiring for 15 V ac Isolated Outputs	6-17
6-20	I/O Points vs Temperature Chart	6-18
6-21	Wiring for 24 V dc Sink Outputs	6-18
6-22	I/O Points vs Temperature	6-19
6-23	Wiring for 16 Circuit 24 V dc Sink Outputs	6-19
6-24	I/O Points vs Temperature Chart	6-20
6-25	Wiring for 16 Circuit 24 V dc Sink Outputs	6-21
6-26	I/O Points vs Temperature Chart	6-22
6-27	Wiring for 24 V dc 2 Amp Sink Outputs	6-22
6-28	I/O Points vs Temperature	6-23
6-29	Wiring of 24 V dc 2 Amp Sink/Source Output	6-23
6-30	I/O Points vs Temperature Chart	6-24
6-31	Wiring for 24 V dc Source Outputs	6-25
6-32	I/O Points vs Temperature	6-26

6-33	Wiring for 24 V dc Source Outputs	6-26
6-34	Wiring for 8 Circuit Relay Outputs	6-28
6-35	Wiring for 16 Circuit Relay Outputs	6-30
6-36	Wiring for 24 V dc Inputs/Outputs	6-32
6-37	Typical Wiring Diagram	6-34
6-38	Sample 24 V dc INPUT/RELAY OUTPUT Circuits	6-35
6-39	Wiring for Thumbwheel Interface	6-37
6-40	Thumbwheel Interface Cable Wire List	6-38
6-41	High Speed Counter Overview	6-40
6-42	HSC Location in 5-Slot Rack	6-41
6-43	HSC Connector Pin Definition	6-42
6-44	Signal Direction	6-43
6-45	UP/DOWN/RESET Input Circuit	6-43
6-46	Encoder with RESET/MARKER Option Resetting Counter Once per Revolution of Encoder Shaft	6-44
6-47	Encoder with RESET Option in Series with Home Limit Switch Such That Counter is Reset When Both Home Limit Switch and RESET/MARKER Pulse are Enabled	6-44
6-48	Encoder With Limit Switch Resetting Counter and Photoelectric Cell Inhibiting the Counter Operation	6-45
6-49	Sample BCD Output Circuit	6-46
6-50	BCD Output Wiring Diagram	6-47
6-51	User Load Wiring Diagram	6-48
6-52	I/O and Counter Function Reference Chart	6-49
6-53	Filter Selection with Dip Switch	6-55
6-54	Module Reference NUMBER/LOGIC Symbol Definition	6-57
6-55	Fast Response Module Logic Diagram	6-59
6-56	Wiring for Fast Response I/O Module	6-60
6-57	I/O Simulator Module Faceplate	6-61
6-58	Analog Input Module Faceplate	6-66
6-59	Analog Output Module Faceplate	6-70
6-60	UL Listed 5-Slot Rack	6-72
6-61	Wiring for UL Listed 115 V ac Input Module	6-73
6-62	Wiring for UL Listed Relay Output Module	6-74
6-63	Wiring for UL Listed 115V ac Output Module	6-75
6-64	I/O Points vs Temperature Chart	6-76
6-65	Wiring for 115 V ac Inputs with Removable Terminal Board	6-76
6-66	I/O Points vs Temperature Chart	6-77
6-67	Wiring for 115/230 V ac Output with Removable Terminal Board	6-77
7-1	Troubleshooting Indicators	7-2
7-2	Battery Location and Connection	7-4
7-3	Location of Extra Memory Socket	7-5
7-4	Accessory Kit for Series One/One Plus	7-7
8-1	Typical One-Shot Timing	8-1
8-2	Typical One-Shot Logic	8-1
8-3	Typical Flip-Flop Timing Diagram	8-2
8-4	Typical Flip-Flop Logic	8-2
8-5	Event/Time Drum Logic	8-3

8-6	Sample Cascaded Counter Logic	8-6
8-7	Typical Machine or Process Power-Up Inhibit Logic	8-7
8-8	Cumulative Timer	8-8
8-9	Sample 24 Hour Time Clock Logic	8-9
8-10	Time Clock Resetting	8-10
8-11	Fast Response Start/Stop Logic	8-11
8-12	Worst Case Timing Diagram	8-11
8-13	Application System	8-12
8-14	Programmable CAM Switch Logic Timing Diagram	8-13
8-15	Programmable CAM Switch	8-14
8-16	Output No. 1 Logic Diagram	8-16
8-17	Wiring Diagram	8-16
8-18	Cut to Length Program	8-17
8-19	Measuring a Random Length	8-18
8-20	Shift Register Example	8-21
8-21	Typical Shift Register Logic	8-22

GEK-90842

Table	1-1	Series One Family General Specifications	1-4
	1-2	Common PC Terminology	1-8
	2-1	Series One/Series One Plus Catalog Numbers	2-5
	3-1	Series One Installation Specifications	3-1
	3-2	CPU Option Settings	3-8
	3-3	Memory Size	3-8
	3-4	Units of Load Supplied by Rack	3-14
	3-5	Units of Load Used by Modules	3-14
	4-1	Error Code Definitions	4-7
	4-2	PC Operation Sequences	4-9
	4-3	Printer Interface Unit Specifications	4-19
	4-4	Printer Requirements	4-19
	4-5	Format and PC Selection	4-22
	4-6	Ladder Diagram Listing Error Messages and Definitions	4-23
	4-7	Boolean Listing Error Messages and Definitions	4-23
	4-8	Timer/Counter Setpoint Specifications	4-33
	5-1	Series One Model E/One Plus Basic Ladder Diagram Instructions	5-2
	5-2	Series One Execution Times	5-3
	5-3	Series One Plus Data Operation Instructions	5-4
	5-4	Series One/One Plus Instruction Groups	5-7
	5-5	Summary of References	5-8
	5-6	Summary of I/O References for 8 Circuit Modules	5-10
	5-7	Effect of Coil 376 (Output Disabler)	5-29
	5-8	Data Operation Function Numbers	5-46
	6-1	I/O Module Catalog Numbers	6-6
	6-2	Maximum Current vs Load Type for Relay Outputs	6-27
	6-3	Maximum Current vs Load Type for Relay Outputs	6-29
	6-4	Maximum Current vs Load Type for Relay Outputs	6-34
	6-5	Number of HSCs vs Discrete I/O Capacity	6-42
	6-6	Manual Mode Output Logic Truth Table	6-53
	6-7	Real Time Comparison Table for Preset Initially > Current Count	6-53
	6-8	Real Time Comparison Table for Preset Initially < Current Count	6-54
	6-9	Output State vs Real Time Comparison Status in Counter Mode	6-54
	6-10	Output Logic in Counter Mode	6-55
	6-11	Maximum Current vs. Load Type for Relay Outputs	6-57
	6-12	Operating Mode Selection	6-58
	6-13	Truth Table for Output in Fast Response Mode (S5 or S7 Have Been Enabled)	6-58
	6-14	Analog Input Module Specifications	6-63
	6-15	I/O Point Definition	6-63
	6-16	Analog Output Module Specifications	6-68
	6-17	I/O Point Definition	6-68
	7-1	I/O Module Fuse List	7-7
	C-1	I/O Module Capability/Compatibility Guide	C-3

GEK-90842

C-2	Summary of Programming References for Series One Family of Programmable Controllers	C-4
C-3	Programming Function Compatibility Guide	C-5
C-4	Examples of Valid System Configurations for I/O Points	C-6
D-1	Series One Junior Capabilities	D-1
D-2	Series Three PC Specifications	D-2
D-3	Series Six CPU Capacities	D-3
D-4	Series Six Plus Combined Memory Configurations	D-4

GEK-90842

History of Programmable Controllers

The factory with a future is here today, with machine and process controls provided by modern electronic devices. Today's automated factory can provide improved system reliability, product quality, information flow, reduced costs, efficiency, and flexibility. One of the basic building blocks of such a factory is an electronic device called a Programmable Controller. This device was first introduced in 1970 and has been refined every 4-7 years as newer electronic components, such as microprocessors, are made available. Today's Programmable Controllers are designed using the latest in microprocessor designs and electronic circuitry which provide reliable operation in industrial applications where many hazards such as electrical noise, high temperature, unreliable AC power, and mechanical shock exist. Here is where the Programmable Controller is in its element; it was designed for the industrial environment from its conception.

Advantages Over Other Control Devices

Programmable Controllers, or PCs or PLCs as they are frequently referred to, offer many advantages over other control devices such as relays, electrical timers and counters, and drum type mechanical controllers. These advantages should be considered beyond just price when selecting any control device:

- Improved reliability
- Smaller space required
- Easier to maintain
- Reusable
- Reprogrammable if requirements change
- More flexible-performs more functions

Series One Programmable Controllers

A complete Series One PC contained in one 5-slot rack can have over 1700 words of user logic, up to 64 timer/counters, and up to 64 I/O points in a panel surface area of only 54 square inches. That is less space than four 4-pole relays might occupy. An available 10-slot rack can contain up to 120 I/O points. By adding additional racks (up to a total of three), the I/O can be expanded up to a total of 112 I/O points in a Series One PC or 168 points in a Series One Plus PC. Modules can be replaced individually without disturbing adjacent modules or their field wiring. The I/O can be intermixed in many configurations, limited only by the module types available (either 4, 8, or 16 circuits per module - see Chapter 6). Users need only purchase those modules required for their application; there is no fixed mix such as 12 in/8 out or 20 in/12 out.

The hand-held programmer can be fixed onto the CPU for quick reference, removed and carried in a pocket for future use, connected to the CPU via a 5 foot (1.5m) cable for flexible temporary use or mounted on the outside of a panel or console. It is a simple pushbutton and display unit designed for easy transportation and rugged use. Programming can also be done with the Portable Programmer or with a Workmaster Industrial computer using Logicmaster 1 application software for Series One or Logicmaster 1F application software for Series One Model E, Series One Plus and Series One Plus 3.7K.

The Series One and Series One Plus PCs are designed to be very cost effective relay or other sequential control replacements. Despite the low cost, there is a lot of capability within the Series One and Series One Plus PCs.

The advantages and features offered by the Series One and Series One Plus PCs include:

- Small size - (64 I/O points in a 5-slot rack) 54 in² panel space, 5 1/2 in. maximum depth, 250 in³ total volume
 - Large Memory Capacity - Up to 1724 words of CMOS or PROM
 - Timers/Counters - Up to 64 (4 digit, 9999 maximum preset)
 - Programming Language- Boolean Based Relay Ladder Data Operations (Series One Plus Only)
 - Maximum I/O - 112 (Series One) - 168 (Series One Plus)
 - Latching relays 28 total
 - 16-bit Data Registers 64 (Series One Plus), 124 with TC references
 - Flexible I/O - Any mix in groups of 4, 8 or 16
 - Replaceable I/O Modules
 - Portable Programmer- Weight only 7 ozs.
 - Personal Password Security Series One Plus and Series One Model E (Permits only Authorized Access To User's Programs)
- Internal and external indication of low battery
 - Reliable operation without fan from 0° to 60° C (convection cooling)
 - Retentive counters
 - Shift Registers (128) Built-in
 - Sequencers Standard - Up to 64, each with up to 1000 steps
 - Meets or exceeds NEMA ICS3-304 for noise rejection
 - Self Diagnostics
 - Internal Power for 24 V dc Inputs
 - Inexpensive
 - High Speed Counter
 - Remote I/O - Saves installation and wiring cost

a40793

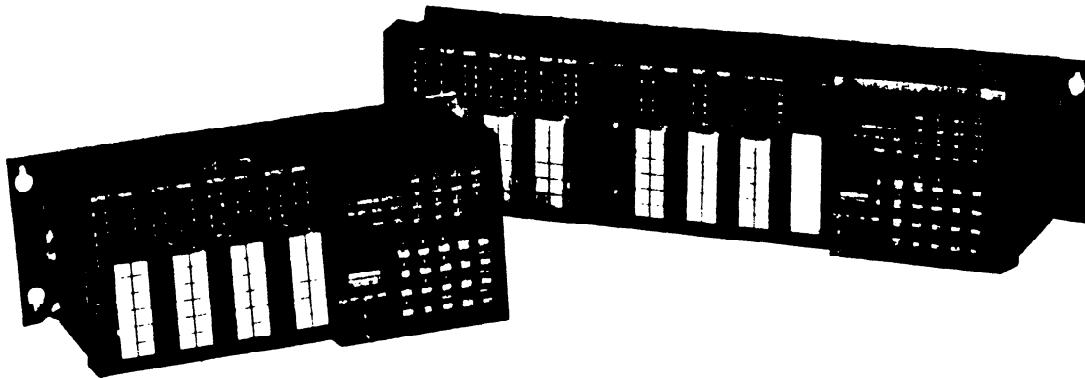

Figure 1-1. Series One/Series One Plus Programmable Controllers

GEK-90842

Series One Model E Programmable Controller

The Series One Model E PC is an enhanced version of the Series One PC that offers more capability while retaining all of the features and functions of the Series One PC. *The Model E requires an IC610CPU104 CPU module.* The additional features of the Series One Model E are:

- **Faster Scan Rate.** Typical scan times are:
 - 8 mSec for a 0.5K word program
 - 12 mSec for a 1.0K program
 - 15 mSec for a 1.7K word program
- **Password Protection.** As with the Series One Plus PC, this is a valuable feature in that it permits only authorized access to user programs stored in the PC memory. A unique 4-digit password is entered by the user and thereafter access to all functions (except monitor functions) is gained through a LOG ON sequence entered by the operator. After completion of required operations, a LOG OUT sequence returns the PC to password protection.
- **Faster Data Communications.** The Series One Model E PC requires the IC610CCM105 Data Communications Unit to communicate with external devices. Communications speed is noticeably faster when communicating with external devices, such as a host computer, than with a Series One PC using either the older version IC610CCM100 or the IC610CCM105 Data Communications Unit. Program upload or download time, and access time to I/O, and timer/counter data is reduced during communications sessions.

Series One Plus 3.7K

The Series One Plus 3.7K PC is an enhancement of the Series One Plus PC which offers greater memory capability, while retaining all other features and functions of the Series One Plus PC. The Series One Plus 3.7K PC uses an IC610CPU106 CPU module that provides 3700 words of CMOS RAM or optional PROM memory (compared to 1700 words of memory available with a Series One Plus with an IC610CPU105 CPU module). A typical scan time for a 3.7K word program is 36 milliseconds.

This additional memory capability allows the Series One Plus 3.7K PC to more fully take advantage of programming with the data operations since those ladder logic programs that require numerous data operations also require more memory than do programs using the basic functions. The additional memory in a Series One Plus 3.7K PC provides the user with a great deal of capability in a small package.

An additional feature of the Series One Plus 3.7K PC is that timers can be programmed to be .01 second timers instead of .1 second. This is done by setting output 770 (SET 770) to the ON condition. The timer preset range with a .01 second duration selected is 0.01 to 99.99 seconds. When selecting timers to be .01 in this manner, care must be exercised to prevent your program from resetting coil 770, since this would cause all timers programmed to then be .1 second timers. Timer durations cannot be mixed, they can all only be .1 second or .01 second in the same program. Any Timer/Counter accumulate registers not being used for a Timer/Counter can be accessed and used as data registers as with the Series One Plus PC. Table 1-1 provides a summary of general specifications for both PCs.

Table 1-1. Series One Family General Specifications

Operating Temperature	0° to 60°C (32° to 140°F)
Storage Temperature	-10° to 70°C (14° to +158°F)
Humidity (non-condensing)	5 to 95%
AC Power Required:	
IC610CHS101/110/130 Rack	
Voltage	115V/230 V ac 15%
Frequency	47-63 Hz
Maximum Load	30 VA (CHS101/110) 36.7 VA (CHS130)
Output Current, Maximum Individual	1.4 A at 5 V dc, (0.4 A, CHS101) 0.8 A at 9 V dc, CHS110 (1.7 A, CHS130), (0.6 A, CHS101) 0.5 A at 24 V dc, (0.2 A, CHS101)
DC Power Required	
IC610CHS114/134 Rack	
Voltage	20.5 - 30 V dc (100% of capacity used) 18 - 30 V dc (90% of capacity used)
Ripple	10% of Input Voltage
Output Current	1.4 A at 5 V dc
Maximum Individual	0.8 A at 9 V dc, CHS114 (1.7 A, CHS134) 0.4 A at 24 V dc, CHS114 (0.5 A, CHS134)
Maximum, Total (All Voltages)	2.2 A, CHS114 (2.3 A, CHS134)
Typical Battery life * (loaded)	2-5 years
shelf life * (no load)	8-10 years
*Depends upon operating temperature	
Memory Size and Type (16-bit words)	700 words (CMOS) or 1724 words (CMOS or EPROM) 3700 words (Series One Plus 3.7K (CMOS or EPROM)
Typical Scan Time per K of Memory	20 mSec (0.5K)
(Only memory programmed is scanned)	Series One 40 mSec (1.0K)
Overhead time must be added to the logic solution for total real scan, time overhead is typically 4 to 5 mSec.	65 msec (1.7K) 8 mSec (0.5K)
	Series One Plus 12 mSec (1.0K)
	and Model E 15 mSec (1.7K)
	One Plus 3.7K 36 mSec (3.7K)
Maximum I/O	112 (Series One) 168 (Series One Plus)
Internal Coils	144
Special Function Coils	4
Retentive Coils (Latches)	28
Timer/Counters	64 (4-digit)
Shift Register Stages	128
Sequencers	64 at 1000 steps each
Data Registers (Series One Plus and Series One Plus 3.7K)	64 (16-bit), up to 124 with unused T/C references

GEK-90842

Programmable Controller Concepts

When using a new product for the first time, there are always new concepts and terms to become familiar with. Although PC's are relatively easy to install, program, and apply, there are some simple principles to follow. Figure 1-2 illustrates a general block diagram of a Programmable Controller. Specific hardware components to illustrate this diagram will be described in Chapter 2.

pc-s1-83-0001

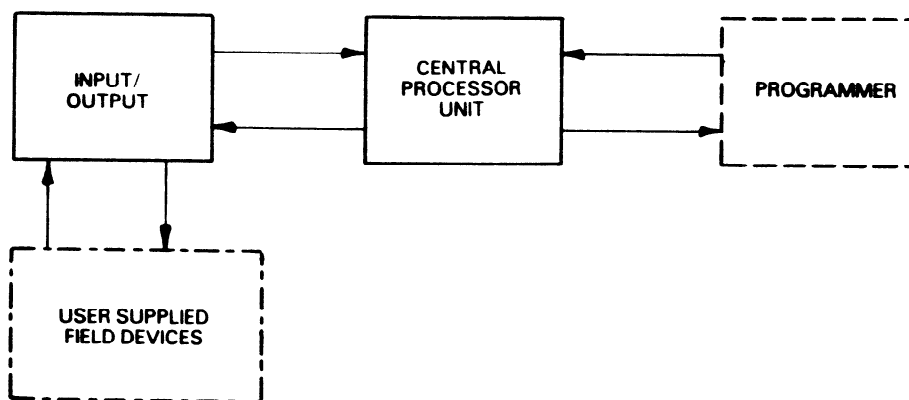

Figure 1-2. Basic PC Block Diagram

Programming the Series One and Series One Plus PCs

The programming devices are used to enter the specific logic the user desires the PC to follow. This logic, to be described in detail in Chapter 5 is what makes the user's PC a unique unit, different from all others unless the identical logic is entered into another unit. Recording and reloading logic from one PC to another or to itself is also a standard feature with the programmers.

Hand-Held Programmer

The programmer can display any previously entered logic, allow the user to edit it (make changes, add or delete portions of the logic), or display the current value of any internal timer or counter. It is a very valuable and powerful piece of peripheral equipment, for entry of logic, control system checkout, and troubleshooting. It can be permanently connected to the CPU or removed without disturbing the operation of the CPU. If removed, one programmer can service several CPUs. The exact quantity of CPUs is dependent upon the expected rate of usage but typically is between 5 and 20 CPUs.

Portable Programmer

The portable programmer uses a liquid crystal display (LCD) screen to allow ladder logic programming for both the Series One and Series One Plus PCs. New programs can be created, previously entered ladder logic displayed and existing logic edited. An on-line monitor function is available when the Portable Programmer is used with the Series One Plus. Programs can be transferred to the PCs or stored

on cassette tape. The program can be printed using a standard parallel or Centronics compatible printer through the printer port located on the rear of the Portable Programmer. For detailed information refer to GEK-90846, which is the Portable Programmer User's Manual.

Logicmaster 1 Family Application Software

Another option available for programming the Series One Family of PCs is the Workmaster industrial computer with Logicmaster 1 Family application software. This software allows you to write, edit, display, and print programs in ladder diagram format. You can view up to 7 lines of your ladder diagram program on one screen. Programs can be annotated by assigning names and nicknames to program elements, assigning labels to coils and adding explanations of program rungs or segments. Many programs can be stored on a single 3 inch diskette and each program can be assigned a unique name. For detailed information on using the Workmaster industrial computer with Logicmaster 1 application software refer to GFK-0075, which is the Logicmaster 1 Family Programming and Documentation Software User's Manual.

Series One Plus Program Protection

The Series One Plus and Series One Model E PCs allow the user to enter a unique password with the hand-held programmer or the LCD Portable Programmer, which prevents unauthorized users or inadvertent program access. When a password is entered, all programmer functions are disabled except the I/O, T/C accumulated value and register monitor functions. In order to have access to all programmer functions when a password has been entered, a log on sequence must be entered.

Function of the Central Processing Unit

The next element of the PC is the Central Processor Unit (CPU). The CPU is the "brain" behind all logical decision making. It reads in the status of the control system, makes decisions based upon the logic it has been provided, and then provides decisions to the actuating portion of the control system. The CPU also performs self checking of its internal operation to ensure reliable operation. If an error is detected, it will shut itself down. The logic entered by the programmer is actually stored in the CPU along with storage for the operation of timers and counters.

Memory Word Length

The memory provided for this storage function is normally measured in K words, where K is an abbreviation for kilo or 1024. Typically, one word is required storage for each function such as a relay contact, timer preset or timer storage. These words can be of various lengths such as 16 bits, 8 bits, or even 4 bits, wherein a bit is the most elementary measurement and can have only two states (on or off). The word length is much like a ruler used to measure wire, sheet steel, or fabric. It can be a yard long (16 bits) or a foot (8 bits) or an inch (4 bits). Numerical values are for illustrative purposes only and do not represent exact ratios. Thus when quoting memory in K words (1K, 2K, 4K, etc.) always check to verify the word length. The Series One and Series One Plus PCs use the most common measurement, 16 bits per word.

GEK-90842

Types of Memory for Program Storage

There are several types of memory used in PCs to store both logic and data. The two used in the Series One and Series One Plus PCs are CMOS and PROM. CMOS or CMOS RAM, which is an acronym for Complimentary Metal-oxide Semiconductor, Random Access Memory, provides a fast, low cost, low power memory that can be both examined (read) and also changed (written) easily. However, it is volatile, which means that it can lose its content if power is removed. To avoid reloading memory (and losing counts and system status) every time power is turned off, the CMOS memory is usually provided (as it is in Series One and Series One Plus) with a back-up battery to maintain its content (not system operation) when power fails. Due to the low power drain of CMOS technology, a single new lithium battery can maintain memory without application of power for up to 2 to 5 years. The battery is not used when the power is applied and the system is operating normally. Its storage or shelf life is many years, typically 8 to 20 years.

The second memory is PROM(Programmable Read only Memory) that again is fast, relatively low cost, and retentive upon loss of power. However, this memory cannot be easily changed. It can be examined (read) at anytime, but to change (write) it requires some special action on the part of the user. In this system, the PROM must be cleared of all previous contents (new PROM, or erased with an intense ultraviolet light) and then placed into a special loader. A previous logic program developed in CMOS is then written into the PROM. Finally, the PROM is removed from the loader and placed into the CPU.

Function of the Input/Output Circuitry

The final element of the PC is the Input/output section. Electrical noise such as spikes on the power lines, inductive "kick-back" from loads, or interference picked up from field wiring is very prevalent in industrial applications. Since the CPU operates at relatively low voltage levels (typically 5 volts), this noise would have serious impact on its operation if allowed to reach the internal circuits of the CPU.

The I/O section, both inputs and outputs, protects the CPU from electrical noise entering via the I/O modules or wiring. The I/O section is where status signals are filtered to remove noise, voltage levels are validated, and where decisions made by the CPU are put into operation. Inputs provide their status to a storage area within the CPU and outputs are driven from similar stored status in the CPU.

In general, the I/O section is modular in design and can accommodate a variety of signals. A complete discussion of the types and capacities available for both the Series One and Series One Plus PCs is provided in Chapter 6. The specific type of module (e.g. 115 V ac or 24 V dc) is usually determined by the field device the user selects. Decisions such as number of 115 V ac solenoids, 24 V dc solenoids, motor starters, limit switches (their voltages), control panel lamps (what voltage), pushbuttons, and external relays have a major impact on the configuration of any PC. These parameters should be established as early as possible in the overall design of the control system. Of course, being a flexible device, the PC configuration either on paper or in hardware, can be changed if requirements change. Typically, the user provides the field devices, wires them to the I/O section, and provides the power source to operate them.

UL Listed Products

Several Series One family products are available that have been tested and approved by the Underwriters Laboratory (UL). These UL listed products should be used in installations where UL listed products are required. The UL listed products include the Series One CPU (IC610CPU101, revision C), 5-slot

rack (IC610CHS111), 115 V ac Input module (IC610MDL135), Relay Output module (IC610MDL181), and a 115 V ac Output module (IC610MDL185). Specifications and wiring information for the UL listed modules can be found in chapter 6 of this manual.

When installing a system requiring UL approval, do not mix non UL listed products with the UL listed products.

Communicating With Other Devices

An available Data Communications Unit (DCU) allows the Series One and Series One Plus to communicate with external devices. The Series One PC uses the IC610CCM100 DCU, while the Series One Model E, Series One Plus and Series One Plus 3.7K PCs use the IC610CCM105 DCU. These devices can be other programmable controllers, computers, or other smart devices. User programs and I/O information in a Series One or Series One Plus PC can be uploaded and downloaded to or from any master device that supports the Series Six CCM2 protocol as defined in the Series Six Data Communications Manual, GEK-25364. For detailed information on how to use a DCU in a Series One or Series One Plus PC system, refer to the Series One Data Communications Manual, GEK-90477.

Remote I/O for Series One and Series One Plus

Another option available for a Series One or Series One Plus PC system is Remote I/O. By using Remote I/O, I/O modules can be located in a rack convenient to the input sensors or the output devices being controlled by the PC at a distance of up to .6 miles (1 km) from the PC. This is accomplished by installing a Link Local module in the CPU rack, a Link Remote module in the distant I/O rack and connecting them through a single twisted-pair cable. For detailed information on using Remote I/O in a Series One or Series One Plus PC system, refer to the Series One Remote I/O Manual, GEK-90507.

PC Terminology

To summarize the preceding discussion of Programmable Controller concepts, table 1-2 provides a definition of terms discussed above that you should be familiar with, relating to PCs. A more complete list of terms is provided in a glossary at the end of this manual.

Table 1-2. Common PC Terminology

TERM	DEFINITION
PC	Programmable Controller or Programmable Logic Controller. An industrial control device using microprocessor technology to perform logic decision making with relay ladder diagram based programming.
Programmer Logic	A device for entry, examination and alteration of the PC's memory including logic and storage areas. A fixed set of responses (outputs) to various external conditions (inputs). All possible situations for both synchronous and non-synchronous activity must be specified by the user. Also referred to as the program.
CPU	Central Processor Unit - the physical unit in which the PC's intelligence resides. Decision making is performed here.
Memory	A physical place to store information such as programs and/or data.

GEK-90842

Table 1-2. Common PC Terminology - Continued

TERM	DEFINITION
K	An abbreviation for kilo or exactly 1024 in the world of computers. Usually related to 1024 words of memory.
Word	A measurement of memory usually 16, 8, or 4 bits long.
CMOS	A read/write memory that requires a battery to retain content upon loss of power.
PROM	A read only memory that requires a special method of loading, but is inherently retentive upon power loss.
I/O	Input/Output - that portion of the PC to which field devices are connected. Isolates the CPU from electrical noise.
Noise	Undesirable electrical disturbances to normal signals generally of high frequency content.
Inputs	A signal, typically ON or OFF, that provides information to the PC.
Outputs	A signal typically ON or OFF, that originates from the PC with user supplied power that controls external devices based upon commands from the CPU.
Modules	A replaceable electronic subassembly usually plugged in and secured in place but easily removable in case of fault or system redesign.
Field Devices	User supplied devices typically providing information to the PC (Inputs: pushbutton, limit switches, relay contacts etc.) or performing PC tasks (Outputs: motor starters, solenoids, indicator lights, etc.).

GEK-90842

Rack Description

The Series One and Series One Plus PCs are provided as a family of racks into which modules can be inserted. Each rack contains a power supply to the right and space for up to either 5 or 10 modules (see figure 2-1). Racks are available in 6 versions, 5 or 10-slot that accept 115/230 V ac input power, 5 or 10-slot that accept 24 V dc, a UL listed 5-slot rack, IC610CHS111 which accepts only a 115 V ac power source, and a low-cost 5-slot rack (IC610CHS101) that does not include an expansion part, 24 V dc terminals for external use, or a RUN relay. Each supplies internal power to the modules inserted into the rack. Mounting is provided by the brackets each with two keyholes at the rear of the rack. All racks are similar. The differences being the function of the rack as determined by the placement of modules by the user, the number of modules which may be inserted into a rack, and the input power required. Figure 2-2 illustrates typical modules for the Series One Family of PCs, illustrating in hardware, the block diagram concept of figure 1-1.

a40535

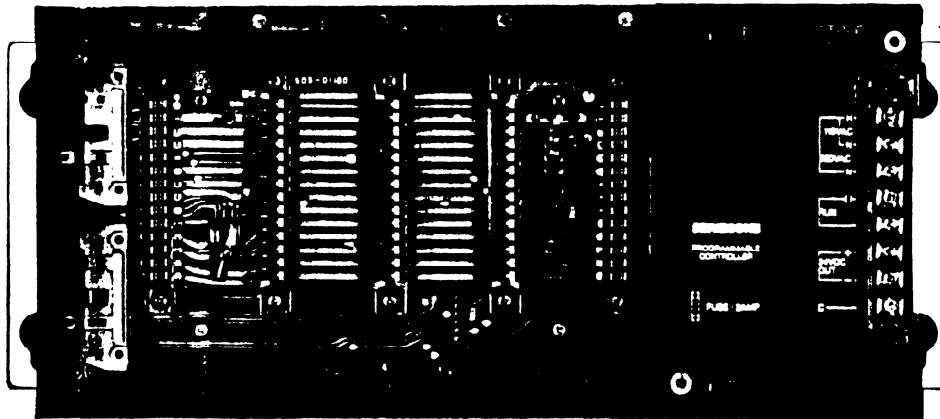

Figure 2-1. Typical Rack

Module Location in Rack

The CPU module is always placed adjacent to the power supply in the first rack; it contains the microprocessor and required memory storage. There is a connector on the CPU to which the programmer is attached when mounted on the rack. As an option, between the CPU and programmer a 5 foot (1.5m) cable can be installed for more flexible operation. The remaining slots can contain I/O modules in any mix of inputs versus outputs or voltage levels desired by the user for his particular application. All modules as well as the programmer are secured to the rack by two snap-locks which can be released by squeezing the module top and bottom toward the center (see Chapter 3 for additional installation details).

a40019

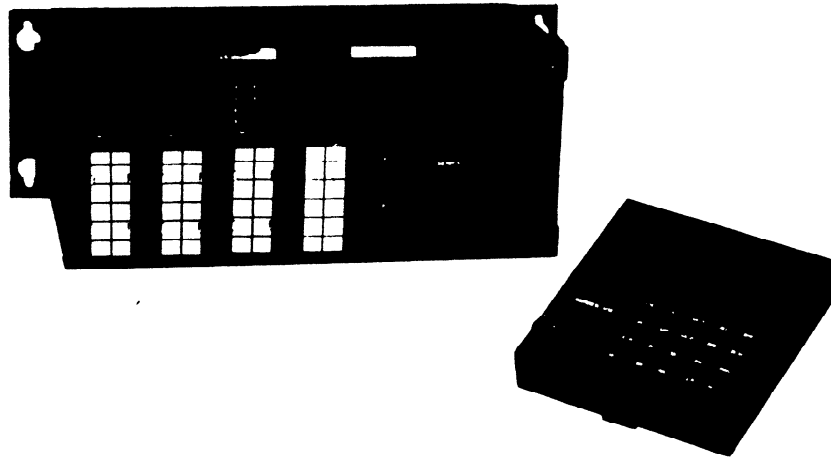

Figure 2-2. Typical Hardware

Heat Dissipation

The rack is designed to dissipate internal heat through convection cooling only and does not require a fan for forced air cooling. However, to ensure efficient operation, free air flow should not be inhibited at the top and bottom of the unit. A minimum of 3 inches (75mm) is recommended at the top and 4 inches (100mm) at the bottom with 6 inches (150mm) between racks. Both sides should be free of obstacles to allow easy removal of the unit, approximately 3 inches (75 mm) from each side excluding the mounting brackets is recommended. Furthermore, the unit should be mounted horizontally as shown in figure 2-3 and not inverted nor rotated 90°. If not oriented as shown, derating of the maximum ambient temperature specification would need to be considered. Placements of other sources of large volumes of heat near the units should also be avoided, especially directly below the rack. For reliable operation, the air entering the bottom of the rack should not be at a higher temperature than 60°C (140°. Wiring to the I/O modules and the power supplies should be placed so as to avoid blocking the air flow, yet provide a suitable service loop to allow easy removal of modules with wiring attached. Wires should be tied to maintain their order in the event they must be disconnected during module replacement.

Adding Racks

If more I/O points are required than one rack can contain, additional racks can be installed similar to the first unit previously discussed (IC610CHS101 cannot be used as an expansion rack). At the left of each rack are two connectors used to connect to additional I/O. An 18 inch (460mm) cable is available to connect the rack containing the CPU module to the first I/O expansion rack. The ends of this cable are marked "CPU" and "EXP" (Expander). The CPU end is plugged into the bottom connector at the first rack and the EXP end similarly connected to the second rack using the top connector (see figure 2-5). If a third rack is used, another cable links the second rack to the third rack, the CPU end is inserted into the bottom connector on the second rack and the EXP end into the top connector on the last rack. Within these added racks, I/O modules can be inserted in any order desired, up to five modules in a 5-slot rack and up to 10 modules in a 10-slot rack. No additional CPU modules can be installed, nor are required.

GEK-90842

a40018

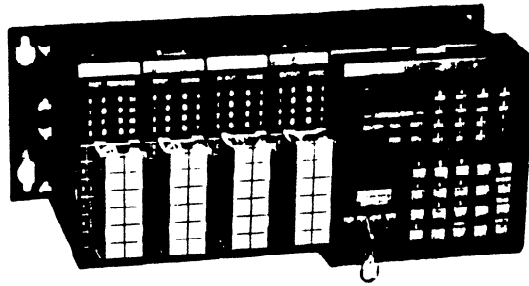

Figure 2-3. Typical (5 Slot) Rack

10-Slot Rack

The 10-slot rack provides in a single housing, as shown in figure 2-4, the same number of I/O module slots as two 5-slot racks. An added advantage of the 10-slot rack is easier and less expensive installation since fewer racks have to be mounted and wired. A system can be configured in many ways to contain various quantities of I/O. Refer to Appendix B, which contains examples of valid I/O rack configurations.

Rack Mount Brackets

Rack mount brackets (IC610CHS191) are available to adapt the 10-slot racks for mounting in 19 inch racks. With the brackets assembled on either version of a 10-slot rack, the rack can be mounted on standard mounting rails in 19 inch cabinets and consoles.

a40792

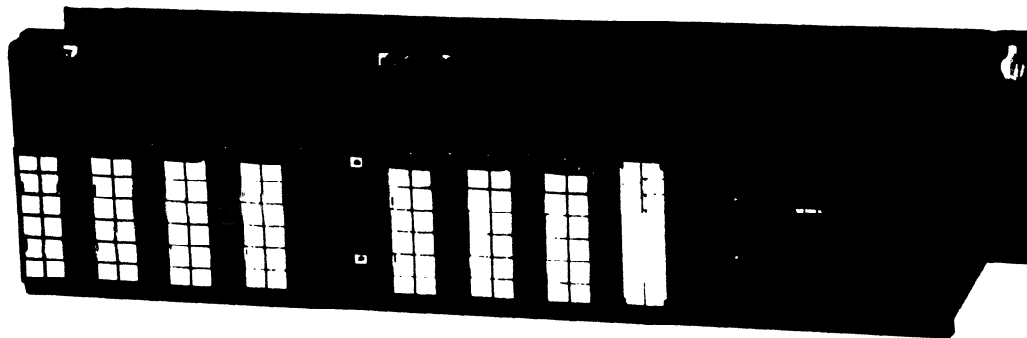

Figure 2-4. Typical (10 Slot) Rack

83-pc-35mm-4-1-31a

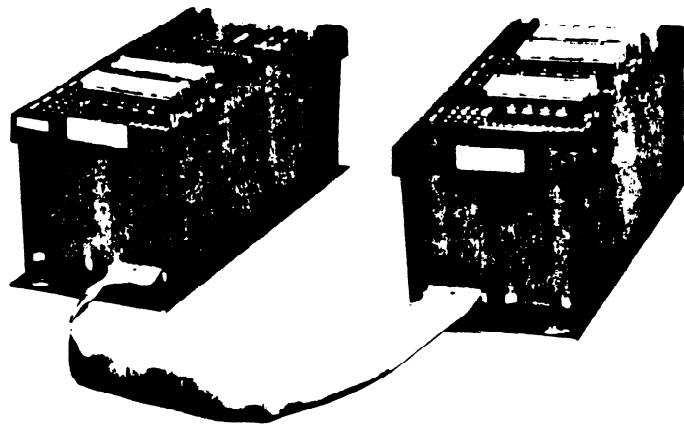

Figure 2-5. Expander Cable Installation

Programmer Tape Port

The hand-held programmer, when installed on the CPU module, provides an auxiliary tape port for memory transfers to peripheral devices. Tape recordings of user programs can be made on virtually any audio cassette recorder and once made can be used to initialize any CPU to that program. Thus programs can be made once and transported to other CPUs without manually being re-entered. Of course, once entered they can be edited if additional tailoring is required. In the unlikely event that a CPU fails, a replacement can be installed and quickly reloaded to perform specifically the task its predecessor was accomplishing, if a tape record was made. The tape recorder functions are discussed in detail in Chapter 4, PC Operation.

Programmer Mount Assembly

A Programmer Mount Assembly (IC610PRG190) is available that can be used to mount and protect the hand-held programmer on the outside of a panel or console. A hand-held programmer, when mounted externally, can be used as an operator interface unit to change timer or counter presets, monitor timer or counter current values, monitor 16 consecutive I/O points, monitor the entire contents of the user program, and, with a Series One Plus PC, monitor register contents. The programmer mount assembly includes a mounting bezel, a clear plastic cover, and a cable fastener. In addition to the mounting assembly, a shielded, round CPU/Programmer cable (Catalog No. IC610CBL102), designed specifically for mounting the hand-held programmer away from the CPU rack must be ordered separately for use when installing the hand-held programmer in this manner.

The Programmer Mount Assembly bezel installs on the outside of a panel or console with only four screws. The hand-held programmer snaps into the bezel using its two snap-locks. A clear plastic cover then fits over the bezel and programmer, thereby protecting it from its industrial environment. The Programmer Mount Assembly can also be used as a table top stand for the hand-held programmer by

GEK-90842

mounting four rubber feet, which are included with the assembly, on the reverse side of the bezel using the panel mounting holes.

a40148

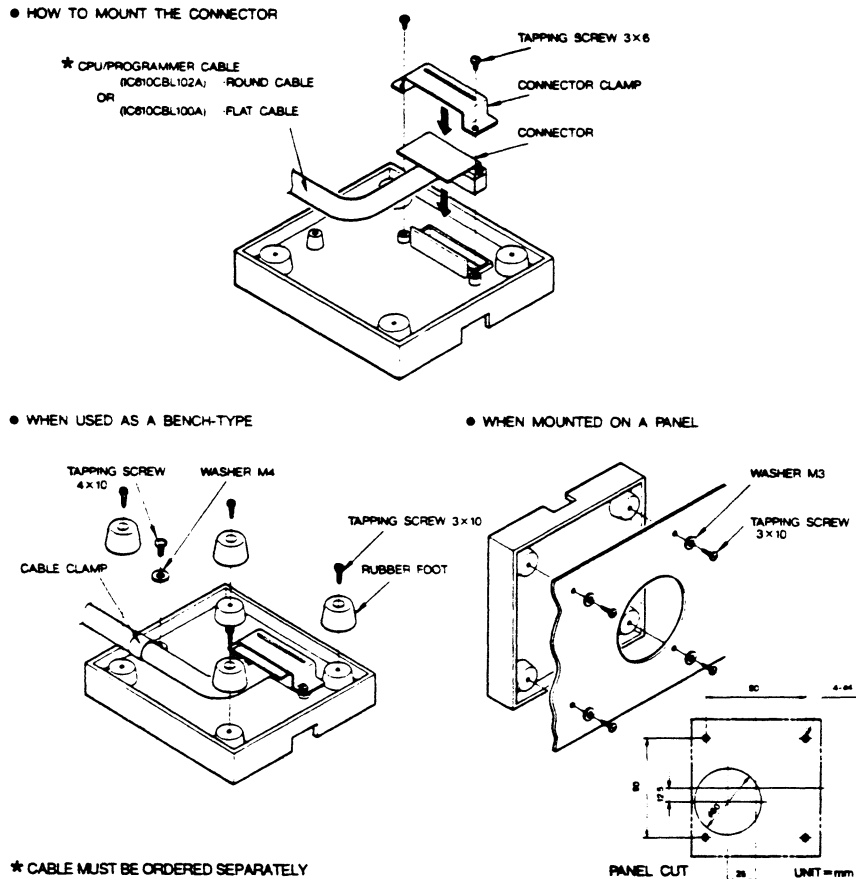

Figure 2-6. Programmer Mount Assembly

Table 2-1 lists the Series One/Series One Plus PC catalog numbers and nomenclature for the various modules, cables, peripherals, and accessories. For detailed information on I/O module specifications and wiring diagrams, see Chapter 6.

Table 2-1. Series One/Series One Plus Catalog Numbers

DESCRIPTION	CATALOG NUMBER
CPU, Series One (700 words of CMOS Memory, standard) Version C is UL listed	IC610CPU101
CPU, Series One Model E (Enhanced Version of CPU101)	IC610CPU104
CPU, Series One Plus (700 words of CMOS Memory, std)	IC610CPU105
CPU, Series One Plus 3.7K (3700 words of CMOS Memory)	IC610CPU106
I/O Expander Cable	IC610CBL101
Programmer with Keylock	IC610PRG100
Programmer w/Keylock (Required for Series One Plus)	IC610PRG105
CPU to Programmer Cable, 5' (1.5m)	IC610CBL100

Table 2-1. Series One/Series One Plus Catalog Numbers - Continued

DESCRIPTION	CATALOG NUMBER
Rack, 115/230 V ac Power Source, 5-slot	IC610CHS110
Rack, 115/230 V ac Power Source, 5-slot (no expansion, 24 V dc Terminals, or Run Relay)	IC610CHS101
Rack 115 V ac Power Source, 5-slot, UL listed	IC610CHS111
Rack w/24 V dc Power Source, 5-slot	IC610CHS114
Rack, 115/230 V ac Power Source, 10-slot	IC610CHS130
Rack, w24 V dc Power Source, 10-slot	IC610CHS134
Filler Module	IC610MDL100
24 V dc Sink Input, 8 Circuits	IC610MDL101
24 V dc Input/Output, 4 Inputs/4 Outputs	IC610MDL103
24 V dc Sink Input/Relay Output, 4 Inputs/4 Outputs	IC610MDL104
Thumbwheel Interface	IC610MDL105
24 V dc Sink Input, 16 Circuits w/LEDs	IC610MDL106
I/O Interface Cable 10' (3m)	IC610CBL105
24 V dc Sink Load Input, 16 Circuits	IC610MDL107
24 V ac/dc Source Input, 8 Circuits	IC610MDL111
24 V ac/dc Source Input, 16 Circuits	IC610MDL112
115 V ac Input, 8 Circuits	IC610MDL125
115 V ac Isolated Input, 4 Circuits	IC610MDL126
230 V ac Input, 8 Circuits	IC610MDL127
115 V ac Input, 6 Circuits (UL listed)	IC610MDL135
24 V dc Sink Output, 8 Circuits	IC610MDL151
24 V dc 2 Amp Sink Output, 4 Circuits	IC610MDL153
24 V dc 2 Amp Sink/Source Output, 4 Circuits	IC610MDL154
24 V dc Source Output, 8 Circuits	IC610MDL155
24 V dc Sink Output, 16 Circuits w/LEDs	IC610MDL156
24 V dc Sink Output, 16 Circuits	IC610MDL157
24 V dc Source Output, 16 Circuits	IC610MDL158
115/230 V ac Output, 8 Circuits	IC610MDL175
115/230 V ac Isolated Output, 4 Circuits	IC610MDL176
Relay Output, 8 Circuits	IC610MDL180
Relay Output, 5 Circuits (UL listed)	IC610MDL185
Relay Output, 16 Circuits	IC610MDL182
115 V ac Output, 6 Circuits (UL listed)	IC610MDL181
High Speed Counter	IC610MDL110
I/O Interface Cable (High Speed Counter)	IC610CBL107
Fast Response I/O	IC610MDL115
I/O Simulator, 8 Inputs	IC610MDL124
Printer Interface Unit	IC610PER151
PROM Writer Unit	IC610PER154
Accessory Kit	IC610ACC120
Lithium Battery	IC610ACC150
PROM Memory (4 Chips), Series One, Series One Junior	IC610ACC151
CMOS Memory (4 Chips), Series One	IC610ACC152
PROM Memory (4 Chips), Series One Plus	IC610ACC155
CMOS Memory (4 Chips), Series One Plus	IC610ACC156
Rack Mount Brackets	IC610CHS191
Programmer Mount Assembly	IC610PRG190

GEK-90842

Table 2-1. Series One/Series One Plus Catalog Numbers - Continued

DESCRIPTION	CATALOG NUMBER
Remote CPU/Programmer Cable	IC610CBL102
Data Communications Unit	IC610CCM105
I/O Link Local	IC610CCM110
I/O Link Remote	IC610CCM111

Hardware Requirements

The Series One and Series One Plus PCs are an excellent relay and timer/counter replacer or substitute for other sequential type control devices, such as drum or stepping switch based systems. However, one question always arises - how much hardware do I need to buy? The answer varies extensively based upon different applications and their attendant complexities. Areas of concern include amount of memory, mix of inputs versus outputs, voltages of I/O, and physical size of the Series One or Series One Plus PC system. The following steps are guides to estimate the requirements of the Series One or Series One Plus PC system. With a little experience, estimating required components will become second nature. If you require assistance, please contact your local GE Fanuc Automation distributor who handles the Series One Family of PCs.

NOTE

CPU Module IC610CPU101A is different from 101B and 101C in that 101A has a 3 digit preset for Timers and Counters, while the updated modules, 101B and 101C have a 4 digit preset. The 101A method of monitoring the accumulated value of Timers and Counters is also different. With the 101A module, each individual Timer or Counter must be accessed by using the sequence SHF, 6XX, MON for each Timer/Counter to be monitored. With the 101B or the 101C CPU module, the keys NXT or PRV will move the monitor display to the next or previous Timer or Counter.

System Estimating

The Series One and Series One Plus PCs are provided with 700 words of CMOS memory as a standard feature. Expansion to 1724 words is possible by adding a CMOS memory chip. If the unit is to be PROM based, the program can be up to 1724 words. The Series One Plus 3.7K PC provides the user with 3700 words of CMOS memory as a standard feature. For average complexity relay replacement, 700 words should be adequate for up to 64 I/O, and the 1724 should be adequate for up to 168 I/O. If the logic is considered more complex than that used as examples in this manual, a representative sample (10 to 15%) of the logic should be programmed. From the amount of memory (on paper) the sample requires, the total memory requirements can be estimated. If in doubt, obtain the optional memory with your unit to ensure simple system design.

The key to many of the answers (cost, physical size, memory requirements, etc.) is the I/O structure. If a design exists such as shown in figure 2-7, assume that all the relays and timers are enclosed within a box; these are the elements to be replaced. This figure is for illustrative purposes only; no indication is given that it performs any real functions. Passing through this box are wires from switches, auxiliary contacts, overload relays, etc.; these are inputs to the control system. There are wires connecting to loads or actuating devices such as solenoid valves, motor starters, indicator lights, etc.; these are outputs

from the control system. The power lines (e.g., 115 V ac and 24 V dc) are not considered I/O, but are important to estimating the number of I/O modules required.

Use the following steps to estimate rack and module requirements; figure 2-7 is used as an example:

1. Add total number of inputs and outputs separating them by type and voltage. (e.g. (4) 115 V ac and (5) 24 V dc inputs plus (3) 115 V ac and (1) 24 V dc output).
2. Divide each separate category by 8 (assume 8 circuit modules), (e.g. (1) 115 V ac and (1) 24 V dc input modules and (1) 115 V ac and (1) 24 V dc output modules). See Chapter 6 for I/O that uses 4 or 16 circuits per module.
3. Add total I/O modules (e.g. 4 I/O modules). One 5-slot rack is required for 1-4 I/O modules, two 5-slot racks for 5-9, and three 5-slot racks for 10-14.
4. If 10-slot racks are used one 10-slot rack is required for 1-9 I/O modules, two 10-slot racks or a 10-slot and a 5-slot rack will contain 1-14 I/O modules.
5. Each additional rack also requires an I/O expander cable. Empty slots should be covered by blank filler plates.
6. Estimate memory requirements as follows:

Total I/O Points	Estimated Memory
1-64	Basic Unit with 700 words
65-168	Add 1K Memory Chip

7. The following optional hardware is available and should be considered when configuring a system:

Hand-Held Programmer	PROM Writer Unit
Portable Programmer	Printer Interface Unit
Extender Cable	Thumbwheel Interface Unit
Programmer Mount Assembly	Timer/Counter Setpoint Unit (Series One Plus)

If the system has not yet been designed, the same basic technique can be used. Inputs are signals the PC will require to perform its assigned functions. Any device or person regardless of intelligence can not respond to events it does not know occurred. Plan to provide the PC all the information you would require to perform the same function. Make a list of those inputs, including source and voltage level (if currently defined). Outputs, on the other hand, are devices the PC will use to perform its functions. Again, even if the PC knows it must do something, if it is not given control over these actuating devices, it can not maintain proper control. Make a list of these devices including their voltage levels and current/power requirements. Use the above steps with the list of I/O devices. In any case, when

GEK-90842

estimating system requirements, review the following standard features as discussed in later chapters to define their impact on your control needs:

- Up to 64 Timers and Counters (4 digits each)
- 128 Stage Shift Register
- Up to 64 Sequencers Each With Up to 1000 Steps
- 28 Latched Relays
- Data Operations (Series One Plus and Series One 3.7K)
- 64 Sixteen Bit Data Registers (Series One Plus and Series One 3.7K)
 - Up to 124 Data Registers are possible when unused T/C references are used as Data Registers.

a42153

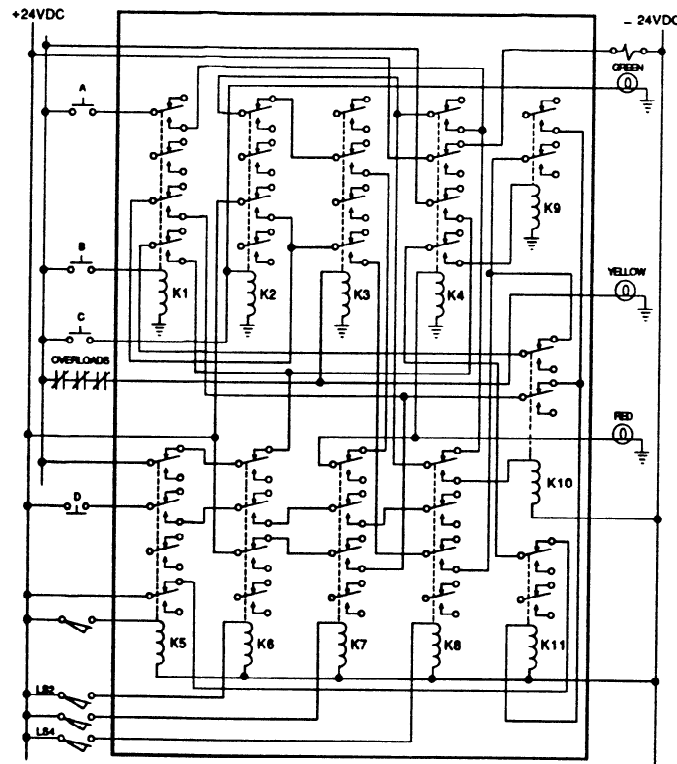

Figure 2-7. Example of Relay Control

Peripheral Devices Supporting Series One Family of PCs

Several peripheral units are available to support a Series One or Series One Plus Programmable Controller. A basic description of these units is provided in the following paragraphs. For a more detailed description of the use and operation of these units, refer to Chapter 4, Operation, in this manual.

Data Communications Unit

The Data Communications Unit (DCU), IC610CCM100/105, provides the ability for external devices to communicate with the Series One, Series One Model E, Series One Plus or Series One Plus 3.7K PC. Series One Model E, Series One Plus and Series One Plus 3.7K PCs require the CCM105 DCU. These devices function as a host to the Series One or One Plus PC and can be other programmable controllers, computers, or other smart devices. User programs and I/O information in the Series One or One Plus PC can be uploaded and downloaded to or from any master device that supports the Series Six CCM2 (Communications Control Module, Version 2) master/slave protocol as defined in GEK-25364, which is the Series Six Data Communications Manual. The Series One or Series One Plus can only function as a slave device during a communications session.

a40537

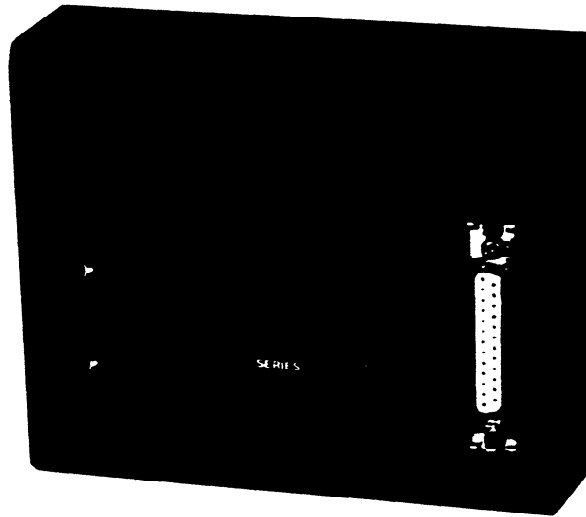

Figure 2-8. Data Communications Unit

GEK-90842

Printer Interface Unit

The Printer Interface Unit, IC610PER151, is a compact, easy to use device that attaches to the Series One, One E, One Plus or One Plus 3.7K PC in the same manner as the programmer. This peripheral interfaces to many readily available personal computer printers and provides a means of obtaining a hard-copy printout of the user program in either boolean or ladder diagram format. Version B works with Series One, One E and One Plus PCs. A higher revision will be available that will also work with the Plus 3.7K PC.

a40538

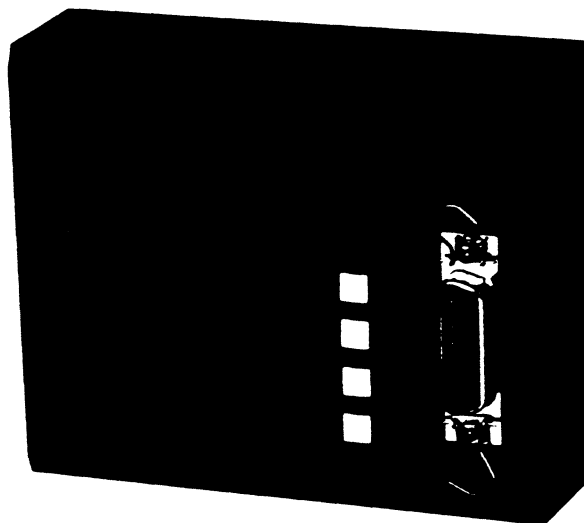

Figure 2-9. Printer Interface Unit

PROM Writer Unit

Also available is a PROM Writer unit, IC610PER154, which allows the user program in CMOS memory to be transferred to PROM memory, thereby providing a convenient method of non-volatile (permanent) storage for those programs. The PROM Writer unit is a compact, easy to use unit which attaches directly to the PC in the same manner as the programmer. In addition to providing a means of non-volatile storage, an added advantage of PROM memory is that several PROMs can be programmed, each containing a different program, for use as required. Version B of this unit replaces version A and can be used with a Series One Plus PC as well as Series One and Series One Junior PCs. Version B will not work with the Series One Plus 3.7K PC. A revised version will be available that can be used for all Series One Family PCs.

a40539

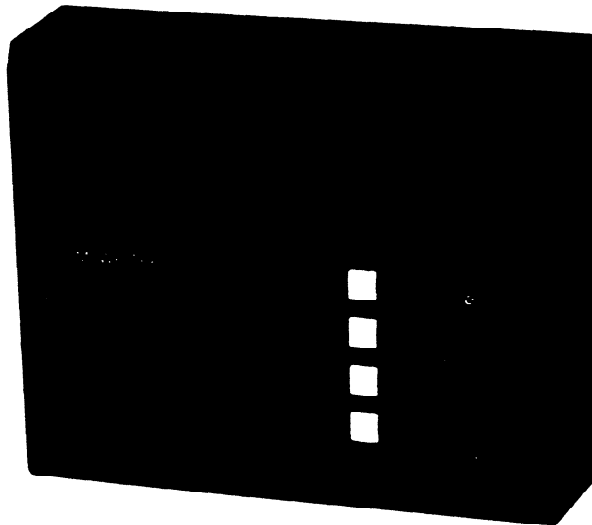

Figure 2-10. Prom Writer Unit

PROGRAMMABLE CONTROLLER	PROM
Series One/One E	2732A-2
Series One Plus/3.7K	27256-25

GEK-90842

Specifications for Installation

The Series One and Series One Plus PC can be easily installed in any NEMA panel or similar metal surface. Figure 3-1 provides details on the mounting of up to three racks except for input voltage requirements to form a single PC system. Since a completed 5-slot rack weighs less than five pounds (10-slot rack, less than 7 pounds), it can be easily installed by one technician. Table 3-1 provides specifications to be met during installation.

Table 3-1. Series One Installation Specifications

Rack Size	
5-slot	11.4" x 4.7" x 5.5" (290 x 120 x 140mm)
10-Slot	18.3" x 4.7" x 5.5" (465 x 120 x 140mm)
Completed Rack Weight (less wiring)	4.5 lbs (2.0 Kg), 5-Slot 6.5 lbs (2.9 Kg), 10-slot
Ambient Temperature	0° to 60°C (32° to 140°F)
Storage Temperature	-10° to 70°C (14° to 158°F)
Humidity	5-95% (Non-Condensing)
AC Power Required:	
IC610CHS101/110/130 Rack	
Voltage	115V/230 V ac 15%
Frequency	47-63 Hz
Maximum Load	30 VA, CHS101/110 (70 VA, CHS130)
Output Current	1.4 A at 5 V dc (0.4 A CHS101)
Maximum Individual	0.8 A at 9 V dc, CHS110 (0.6 A, CHS101; 1.7 A, CHS130)
	0.5 A at 24 V dc, (0.2 A, CHS101)
DC Power Required	
IC160CHS114/134	
Voltage	20.5 - 30 V dc (100% of capacity used) 18 - 30 V dc (90% of capacity used)
Ripple	10% of Input Voltage
Output Current	1.4 A at 5 V dc
Maximum Individual	0.8 A at 9 V dc, CHS114 (1.7 A, CHS134) 0.4 A at 24 V dc, CHS114 (0.5 A, CHS134)
Maximum, Total (All voltages)	2.2 A, CHS114 (2.9 A, CHS134)
Run relay	250 V, 4 amp, Resistive Load (Not Present on CHS101)
Vibration	Meets JIS C 0911 IIB Class 3 Tested to MIL STD 810C Method 514.2
Shock	Meets JIS C 0912
Noise Immunity	Meets NEMA ICS3-304

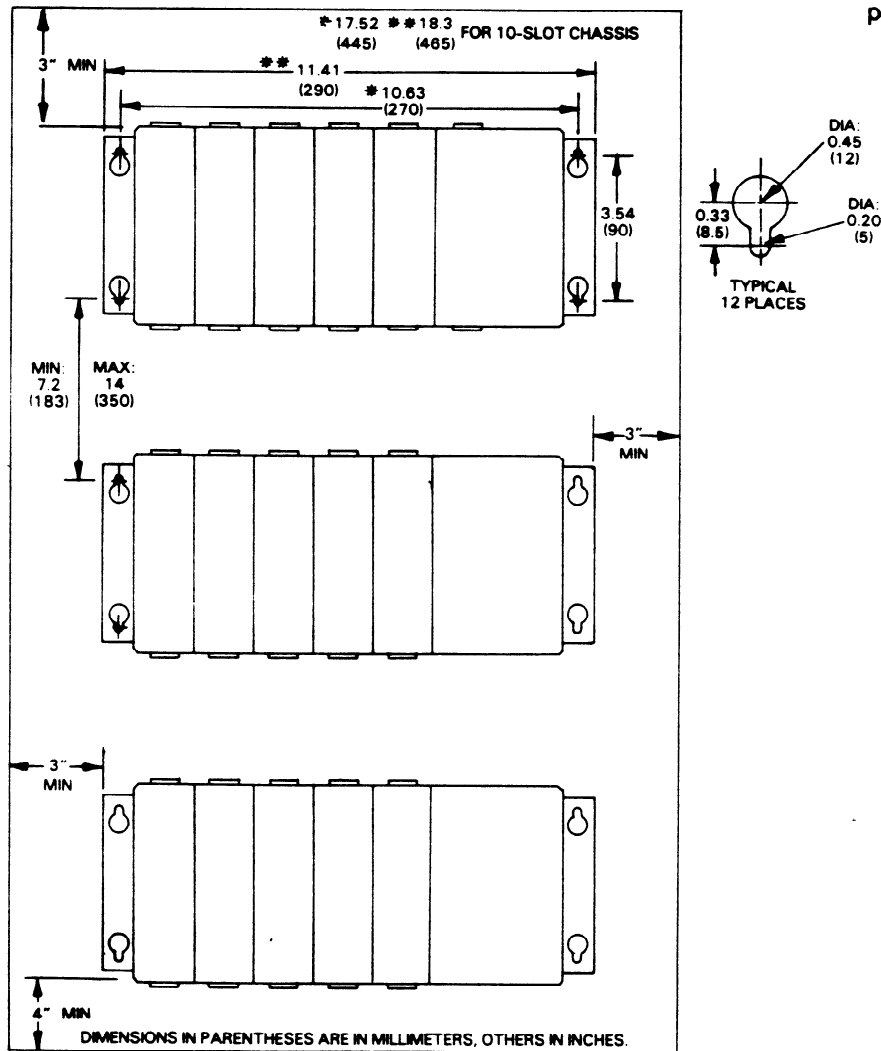

Figure 3-1. Rack Mounting Dimensions for Proper Heat Dissipation

Installation

Unpack each unit carefully and retain any instructions shipped with the units. Two spare fuses are attached to the top of each rack; they should be removed and retained for future use. The racks can be installed either with no modules or with modules installed. The following steps will assist in organizing and simplifying the installation of a Series One or Series One Plus PC System.

Racks

1. Using the rack as a template, mark where mounting holes are to be drilled.
2. Drill the four mounting holes (1/4" (6mm) if using pass through bolts, or 3/16" (5mm) if using tapped holes).
3. Insert top 2 bolts (3/16" X 1-1/2" or 5mm X 40mm), put unit in place, and loosely secure with washers, lock washers and nuts.

OR

GEK-90842

4. Tap holes and insert top two bolts. Place unit onto mounting bolts and loosely secure.

NOTE

When inserting the 2 top bolts, attach the green jumper as shown in figure 3-2. This jumper wire is packed with each rack and provides a method of grounding the rack when an earth ground (such as the shield or hard wire in the power cord) is also connected to a mounting bolt.

5. The power supply ground connection is made to one of the mounting bolts (step 3 or 4 above). A jumper wire is included with each rack to interconnect the mounting brackets. The "C" terminals on the power supplies are interconnected when more than one rack is used. Otherwise, the "C" terminal is not connected to anything in a single rack system.

a40147

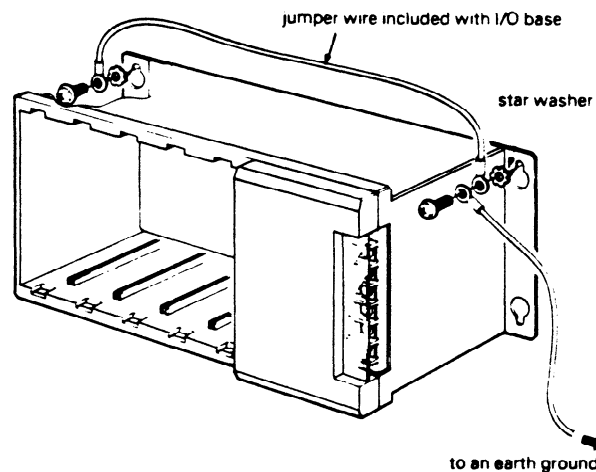

Figure 3-2. Recommended Rack Grounding

6. Complete the installation of the bottom two bolts and tighten all mounting hardware. Power supplies are shipped installed in each base.
7. If additional racks are to be used, repeat steps 1-4 above. If only one base unit is used, go to step 15.

NOTE

When drilling or tapping holes ensure that metal chips do not enter unit already installed. Clear work area before installing base units.

8. Obtain flat ribbon cable used to interconnect racks. Locate end marked "To CPU", remove dust cover from bottom connector of first (CPU) rack, and insert cable connector (see figure 3-4) fully into receptacle until locking tabs capture connector.
9. Fold cable as shown on figure 3-7. Remove dust cover from top connector of second rack and insert opposite end of cable marked "To Expander."
10. Secure cable in place with wire wraps or cable ties.

11. If a third rack is used, repeat steps 8-10 with CPU end of cable in bottom connector on second rack and Expander end in top connector of third and last rack.
12. If a 10-slot rack (IC610CHS130 or IC610CHS134) is to be included in a system, it can be mounted on standard mounting rails in 19 inch cabinets and consoles by attaching the rack mount brackets. Two adapter brackets and hardware required for assembly are included in the bracket package, IC610CHS191.

a40214

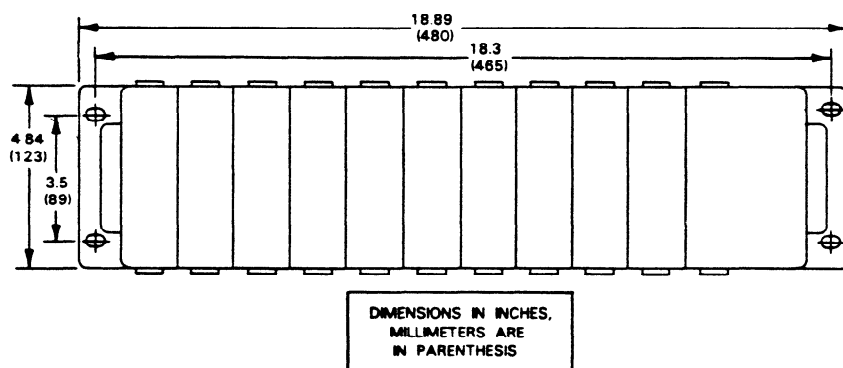

Figure 3-3. 10 Slot Rack, 19 Inch Mounting Dimensions

a40280



Figure 3-4. I/O Expansion Cable Connection

13. Unused rack connectors such as at the top of the CPU unit and the bottom of the last rack should retain their dust covers.

GEK-90842

14. Inside each 5-slot rack at the rear of the leftmost module slot is a two position switch. On the CPU unit, this switch must be positioned towards the left. On the first expander it must be towards the right. If a third rack is used, the switch must be towards the left again. An exception to the described switch settings is when a 5-slot rack is used as an expansion rack in a Series One Plus system, where the CPU rack is a 10-slot rack. In this case, the switch must be positioned to the left. This switch is not included in the IC610CHS101 rack, since it cannot be used as an expansion rack.

CAUTION

All switches must be set properly. The Series One or Series One Plus PC may not function correctly if any switch is not in the correct position.

15. The 10-slot racks, IC610CHS130/134 have two bridge connectors on the back plane which must be configured. Bridge connector SW1, located between slots 3 and 4, has 2 positions EXP and CPU. The jumper must be positioned on the corresponding pins to specify whether the rack is a CPU rack or an Expansion rack. Bridge connector SW2, located between slots 9 and 10, selects the address to be assigned to slot 10 and the expansion rack slots. The selections are either 100 EXP or 700. Figure 3-5 shows the location of SW1 and SW2.

a40794

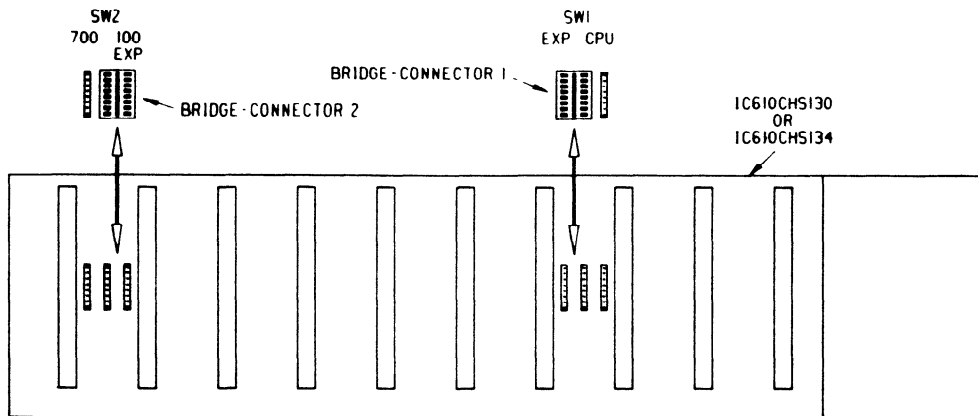

Figure 3-5. I/O Addressing Switches in Series One Plus 10 Slot Racks

16. Example of SW1 and SW2 settings are shown below in figure 3-6.

a40795

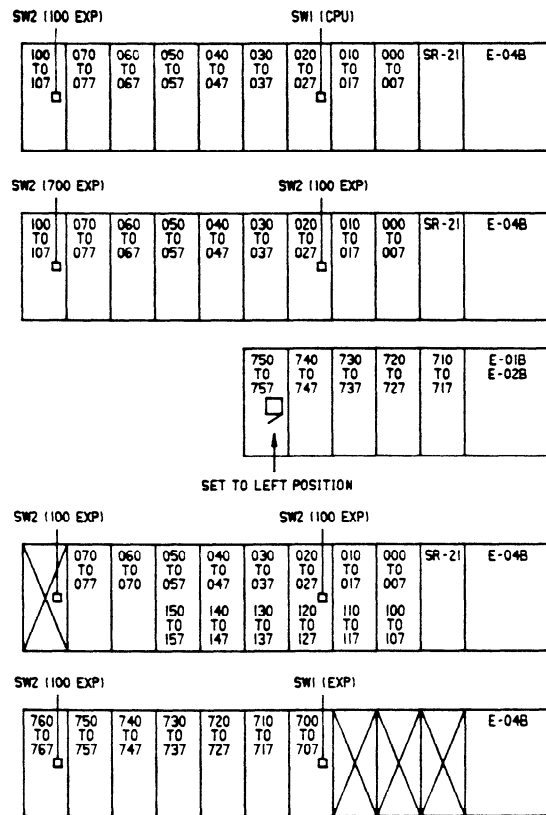

Figure 3-6. Examples of Rack Configuration Switch Setting Series One Plus

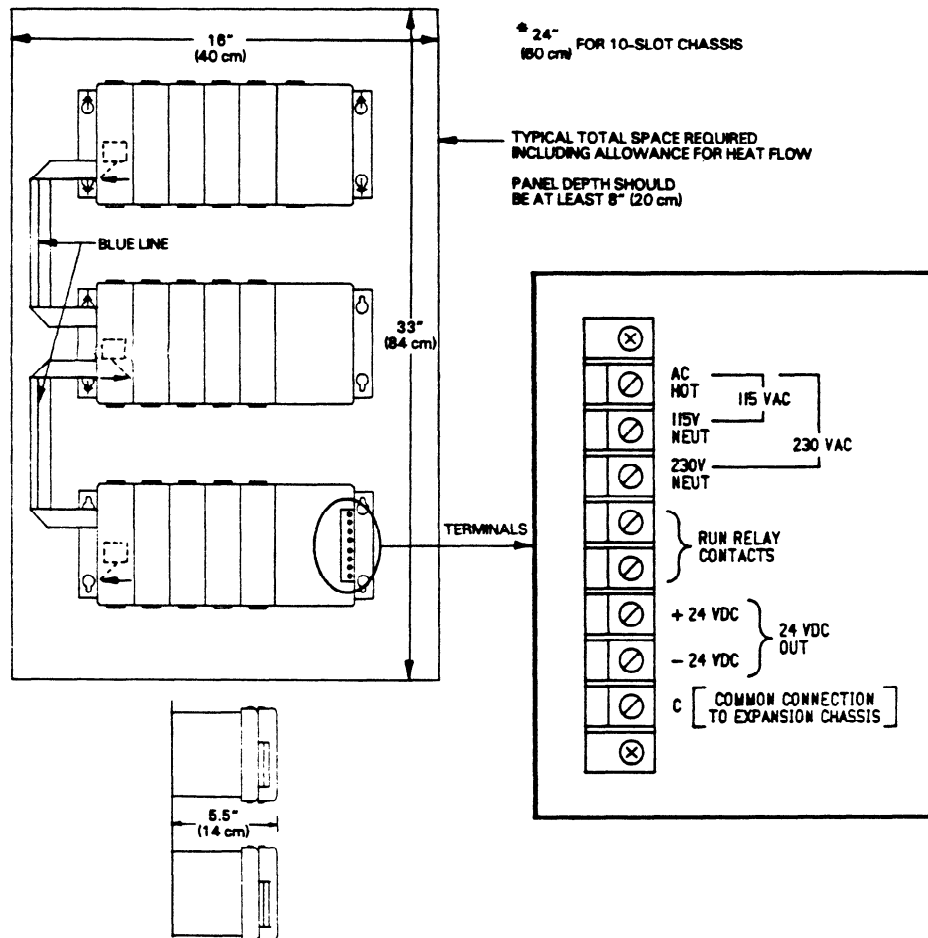

Figure 3-7. Typical Installation Dimensions

NOTE

Ground Connection should be made to mounting bracket, not to the terminal strip.

CPU

17. Locate the CPU module (see figure 3-8) and set switches and shorting bridge connectors per table 3-2. If additional CMOS or PROM memory is to be installed, now is the time to do it. For detailed instructions, see Chapter 7.
18. The CPU module must be installed adjacent to the power supply in the first or topmost rack.

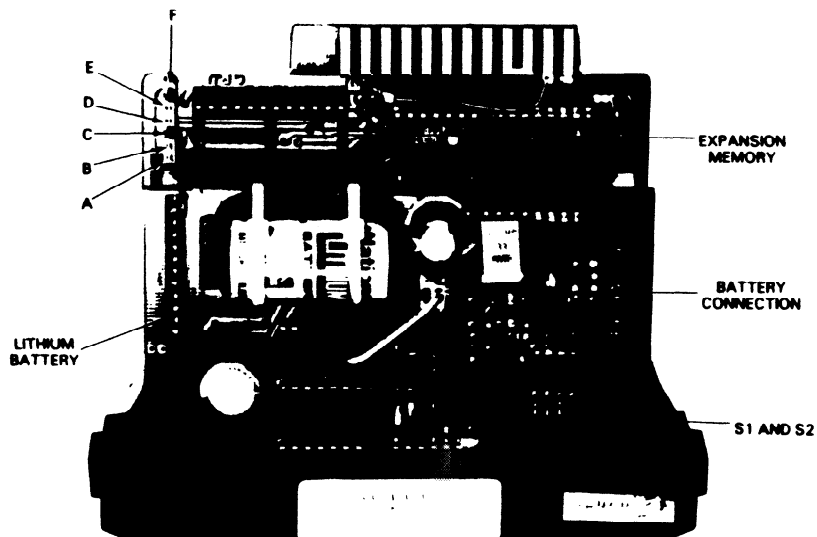

Figure 3-8. CPU Module

Table 3-2. CPU Option Settings

SWITCH 1 - POWER UP FUNCTIONS		SWITCH 2 - MEMORY TYPE	
OFF	Clear Coils	OFF	PROM
ON	Retain Coils	ON	CMOS

NOTE

ON is Towards the Faceplate. Factory setting is: Clear Coils and Select CMOS memory. Retain Coils affects 340-373 only. Counters and Shift Registers are always retentive.

Table 3-3. Memory Size

MEMORY SIZE	CONNECT JUMPERS BETWEEN PINS
700 Words CMOS	A B and D E
1724 Words CMOS	B C and E F
1724 Words PROM	A B and D E

CAUTION

Remove jumper $\overline{E F}$ before installing PROM. Battery will discharge in a very short time if $\overline{E F}$ is not disconnected.

NOTE

Pin A is towards the faceplate. Factory setting is: 700 words CMOS, 1724 words PROM (same Setting)

GEK-90842

a40282

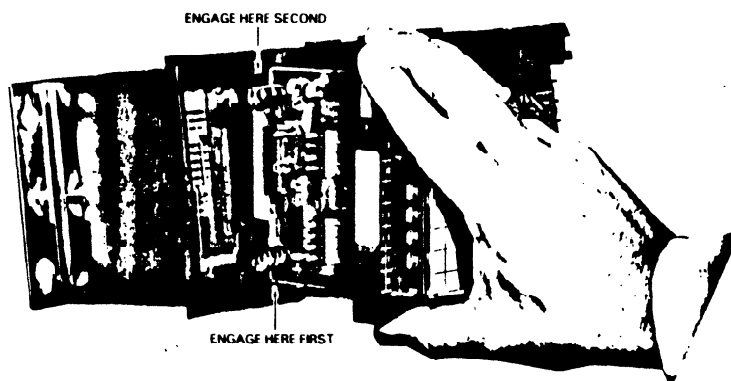

Figure 3-9. Proper Module Insertion

19. Tilt the module approximately 10° as shown in figure 3-9. Insert bottom of the large printed circuit board into the bottom card slot.
20. When the bottom slot is engaged, rotate the module to engage top slot. Slide module into base unit until it is firmly seated and snap locks engage.

I/O

21. Other modules are installed into racks at slot locations as determined by installation plans. Follow steps 19 and 20 above for each I/O module.
22. To remove a module, squeeze the snap locks top and bottom (see figure 3-10) towards the center and pull the module straight out. Squeeze force should be approximately 10 pounds (5 Kg) and pull force 8-12 pounds (4-5 Kg).

a40283

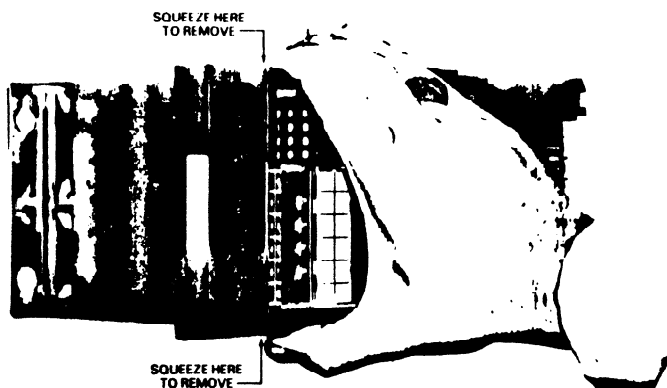

Figure 3-10. Proper Module Removal

Power Connections

23. AC or DC power connections are made to the terminal strip on the far right of each unit. See table 3-1 for power requirements. The minimum recommended wire size for power connections is AWG No. 18 (1mm).
24. Strip 0.4 ± 0.1 inches (10 ± 2 mm) of insulation from each wire (hot, neutral, and ground or + and -) or place a No. 6 insulated lug (ringed or forked) onto each wire.
25. Remove plastic cover over terminal strip and retain. Connect the hot wire to the top terminal. The neutral is connected to either the next (second) terminal for 115 V ac operation or the third terminal for 230 V ac operation as marked on the base unit. For 24 V dc racks, connect the + and - terminals to the DC power source.

WARNING

Do not use the top screw for power connections; it secures the terminal block. Verify connections before applying power.

26. Connect an earth ground wire to the rack mounting bracket as shown in figure 3-2. (Typically this ground wire is the green wire from the ac power source.)

WARNING

Ensure that all exposed wiring is either under the screw-down plate of the terminals or insulated by shrink tubing or sleeves.

27. The terminals labeled +24 V dc and -24 V dc provide 24 V dc @ 100 mA for connection to an external sensor (not on IC610CHS101).
28. The two remaining terminals are used with the RUN indicator. Use of this standard feature on all racks is optional. It can be used to drive an external indication of the functional state of this rack. The Run relay is closed when the CPU is scanning (not on IC610CHS101).
29. If the Run indication is desired, it can be wired separately to an external indicator (light, bell, whistle, etc.) or in series with other racks. Follow steps 24-25 above for guidance on connecting these wires. Then replace the plastic cover.

I/O Field Wiring

30. Recommended wire size for connection to the I/O modules is stranded AWG No. 12 (0.65-2mm) wire. Two wires per terminal are possible with AWG No. 14 (0.65-1.6mm) wire.
31. Strip 0.3 ± 0.05 inches (8 ± 1.5 mm) from each wire to be connected to the I/O modules or install a No. 6 insulated lug (ringed or forked). Bare wire connections are recommended for multiple wire connections to one terminal.
32. Carefully remove plastic covers over I/O terminal connections by lifting top or bottom leg and sliding it to right or left.
33. Starting with the lower terminals, connect the field wires to all I/O terminals. Power connections such as those to commons (C) should be made last. No connections are required to unused circuits; however, screws on unused terminals should be tightened.

GEK-90842

34. For 16 point I/O modules that connect to I/O through a connector on the faceplate, secure the connector on the I/O Interface cable to the connector on the module.

WARNING

Ensure that wires to the top set of terminals do not extend beyond the screw-down plate. Any wire exposed before the terminal plate must be covered by shrink tubing or sleeves.

35. Wires should be laced together to leave a service loop adequate for removal of I/O modules without disconnecting wires. See figure 3-11. After testing of I/O wiring, replace plastic covers.

a40017

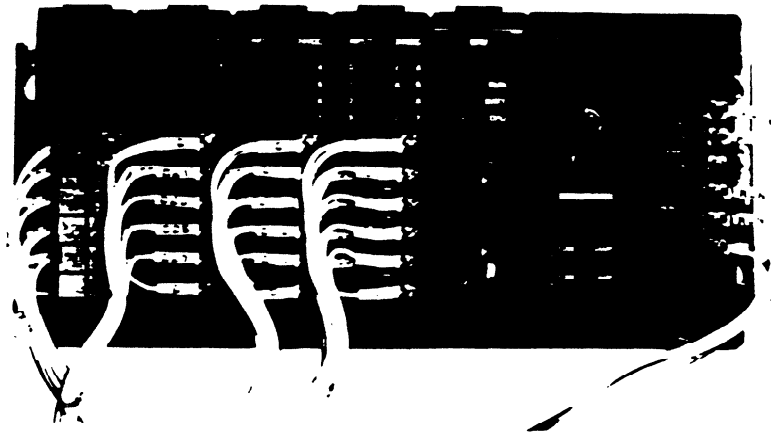

Figure 3-11. Typical Routing of I/O Wiring

Programmer

36. The hand-held programmer (catalog no. IC610PRG100 or IC610PRG105) can be placed over the CPU and power supply for permanent or temporary mounting. Its connector fits into the receptacle on the CPU and it snap locks onto the power supply.
37. If an extender cable is used with the programmer, it should be installed next or when required. One end of the cable has a push tab (see figure 3-12). This end is connected to the programmer (see figure 3-13). The other end is connected to the 26-pin connector on the CPU. Both ends are keyed for proper installation. The red edge of the ribbon cable is installed up at both ends.

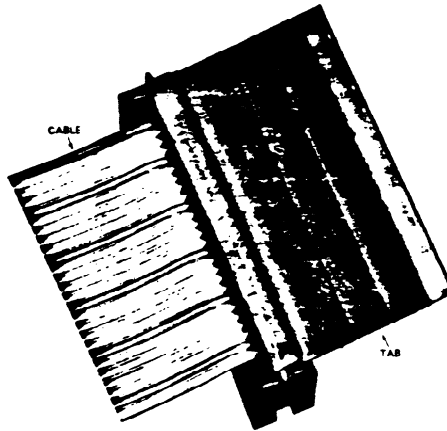

Figure 3-12. Pull Tab on Programmer Cable

NOTE

For proper noise immunity, it is recommended that the extender cable be used on a temporary basis and not permanently installed with the programmer.

38. To install the programmer directly onto the CPU, align the programmer on the outside dimensions of the power supply and gently push down to engage snap locks.

CAUTION

To ensure proper CPU operation, it is recommended that the programmer not be connected nor disconnected with ac power applied.

83-pc-35mm-4-3-31a

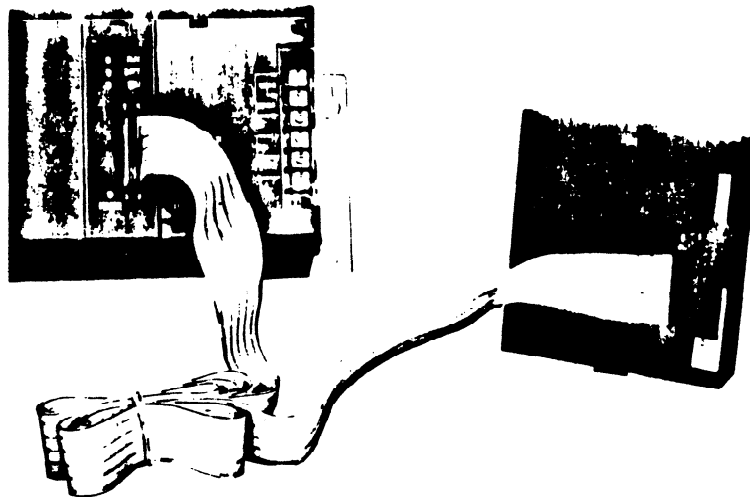

Figure 3-13. Installation of Programmer Cable

GEK-90842

39. The Programmer Mount Assembly (catalog no. IC610PRG190) can be used when installing the hand-held programmer on the outside of a panel or console, or can be used as a table top stand for the programmer. Figure 3-14 shows how to install the mounting assembly. *The CPU/Programmer cable must be ordered separately.*

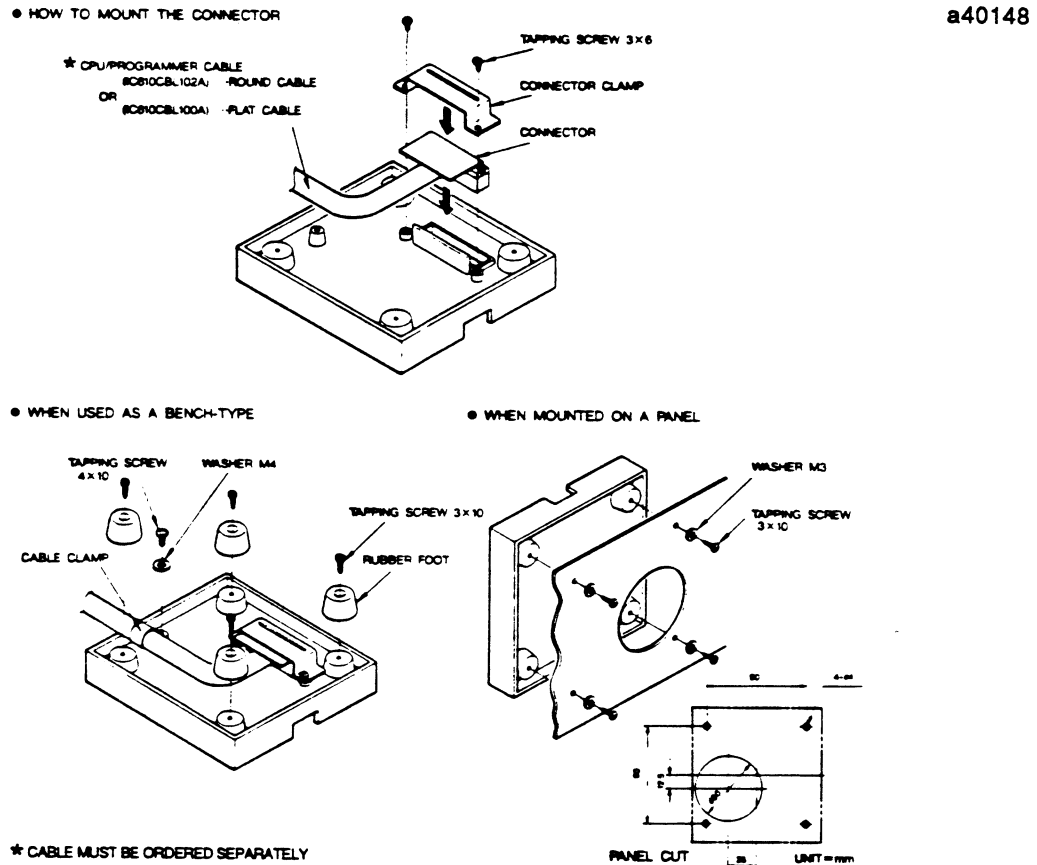

Figure 3-14. Programmer Mount Assembly

Power Supply Limitations for Racks

If the power supply in either a CPU or expansion rack should become overloaded, unpredictable system operation may occur. To ensure that this does not happen, the total current capabilities of the modules placed in the rack must not exceed the current carrying capabilities of the rack power supply.

Units of Load

The power used by each module is expressed in (units of load), where 1 unit equals 10 mA. Calculations are based on the worst case condition with all inputs and outputs on. Table 3-4 list the units of load supplied by each rack, and table 3-5 is a list of units of load used by each module. When configuring a rack, note the units of load supplied, then add the total units of load used by the modules you have selected. The total units of load for the modules must not exceed the total units of load supplied by the rack. If they do, the system should be redesigned.

Table 3-4. Units of Load Supplied by Rack

CATALOG NUMBER	RACK DESCRIPTION	POWER SUPPLIED IN UNITS OF LOAD			
		+5 V	+9 V	+24 V	+24 V External
IC610CHS101	5-slot, 115/230 V ac	40	60	20	-
IC610CHS110	5-slot, 115/230 V ac	140	80	40*	10
IC610CHS111	5-slot, 115 V ac, UL	140	80	50	10
IC610CHS114	5-slot w/24 V dc P/S	140	80	40	-
IC610CHS130	10-slot, 115/230 V ac	140	170	50*	10
IC610CHS134	10-slot w/24 V dc P/S	140	170	50	-

*If an external sensor is connected to the 24 V + and - terminals on the power supply, the current used by the sensor (up to the maximum of 100 mA), should be deducted from the available listed units of load.

Table 3-5. Units of Load Used by Modules

CATALOG NUMBER	MODULE DESCRIPTION	POWER USED IN UNITS OF LOAD		
		+5 V	+9 V	+24 V
IC610CPU101	CPU	25	-	-
IC610CPU104	CPU25	-	-	-
IC610CPU105	CPU	25	-	-
IC610CPU106	CPU	25	-	-
IC610PRG100	Programmer	6	5	-
IC610PRG105	Programmer	6	5	-
IC610MDL101	24 V dc Sink Input (8)	-	1	10
IC610MDL103	24 V dc In/Out (4/4)	-	2	7
IC610MDL104	24 V dc In/Relay Out (4/4)	-	20	6
IC610MDL105	Thumbwheel Interface	-	1	9
IC610MDL106	24 V dc Sink In w/LEDs (16)	-	3	24
IC610MDL107	24 V dc Sink Load In (16)	-	3	23
IC610MDL110	High Speed Counter	-	7	-
IC610MDL111	24 V dc ac/dc Input (8)	-	1	-
IC610MDL112	24 V ac/dc Source In (16)	-	13	-
IC610MDL115	Fast Response I/O (4/2)	-	8	6
IC610MDL124	I/O Simulator (8) Inputs	-	1	11
IC610MDL125	115 V ac Input (8)	-	1	1
IC610MDL126	115 V ac Isolated Input (4)	-	1	-
IC610MDL127	230 V ac Input (8)	-	1	-
IC610MDL135	UL, 115 V ac Input (6)	-	1	-
IC610MDL151	24 V dc Sink Output (8)	-	2	3
IC610MDL153	24 V dc 2A Sink Out (4)	-	1	1
IC610MDL154	24 V dc Sink/Source Out (4)	-	1	10
IC610MDL155	24 V dc Source Output (8)	-	3	-
IC610MDL156	24 V dc Sink Out w/LEDs (16)	-	4	0
IC610MDL157	24 V dc Sink Out w/LEDs (16)	-	4	10

GEK-90842

Table 3-5. Units of Load Used by Modules - Continued

CATALOG NUMBER	MODULE DESCRIPTION	POWER USED IN UNITS OF LOAD		
		+5 V	+9 V	+24 V
IC610MDL158	24 V dc Source Out w/LEDs (16)	-	20	-
IC610MDL175	115/230 V ac Output (8)	-	16	-
IC610MDL176	115/230 V ac Isolated OUT (4)	-	16	-
IC610MDL180	Relay Output (8)	-	34	-
IC610MDL181	UL, Relay Output (5)	-	23	-
IC610MDL182	Relay Output (16)	-	48	-
IC610MDL185	UL, 115 V ac Output (6)	-	12	-
IC610CCM105	Data Communications Unit	30	-	-
IC610CCM110	I/O Link Local	60	-	-
IC610CCM111	I/O Link Remote	60	-	-
IC610PER151	Printer Interface Unit	26	-	-
IC610PER154	PROM Writer Unit	50	-	-
IC609CTU100	Timer/Counter Setpoint Unit	4	1	-

1 unit of load = 10 mA. Calculations are based on the worst case, that is, all inputs and outputs on.

Safety Considerations

When planning the layout of a system, safety should be a prime consideration. System planning should include procedures and methods to ensure the physical safety of personnel, the Series One or One Plus system and the equipment or process being controlled. Those personnel who are involved in the planning and installation of a system should be familiar with all local and national electrical codes as well as installation instructions in this manual.

All practices should be followed that are specified by the IEEE (Institute of Electrical and Electronic Engineers) Standard 510 which includes tray and conduit spacing and wiring procedures. A copy of this standard can be obtained by writing:

*Institute of Electrical and Electronic Engineers
345 East 47th Street
New York, NY 10017*

Recommended Field Wiring Procedures

The following procedures are recommended when running field wiring:

- Low-level signal wires should be separated from other field wiring.
- AC power wiring should be separated from DC field wiring.
- Wiring should not be routed near devices causing electrical interference.
- If severe noise problems are present, additional power supply filtering or an isolation transformer may be required. Contact your GE Fanuc Automation sales representative if assistance is required.
- Proper grounding should be provided to minimize hazards to personnel.
- Label all I/O wires. Circuit numbers or other identification can also be marked on the cover over the wire terminals on each I/O module.
- I/O wires should be no larger than No. 12 AWG.

Introduction to PC Operation

After completing the installation procedures described in the previous chapter, your Series One or Series One Plus PC is ready for operation. This chapter describes the operation sequences for those PCs. A description of the features and functions of the programmer are the basis for the information in this chapter. The last portion of this chapter describes the operation of peripheral devices that can be used with the Series One or Series One Plus. The information in this chapter will allow you to become familiar with the programmer keys and the keystroke sequences required for the various programmer operations.

Programmer

The hand-held programmer (figure 4-1), when connected to a PC by one of the three methods described in the previous chapter, can be used for entering a new program, examining a previously entered program, editing (changing) a previously entered program if required, monitoring the status of input or output points, displaying the contents of registers, and displaying timer or counter accumulated values. In addition, with the Series One Plus, a password can be entered with the programmer to protect the contents of your program from unauthorized or inadvertent entry or changing. Its features and functions are described in the following paragraphs. For detailed descriptions of the programming functions, refer to programming, Chapter 5.

a41927

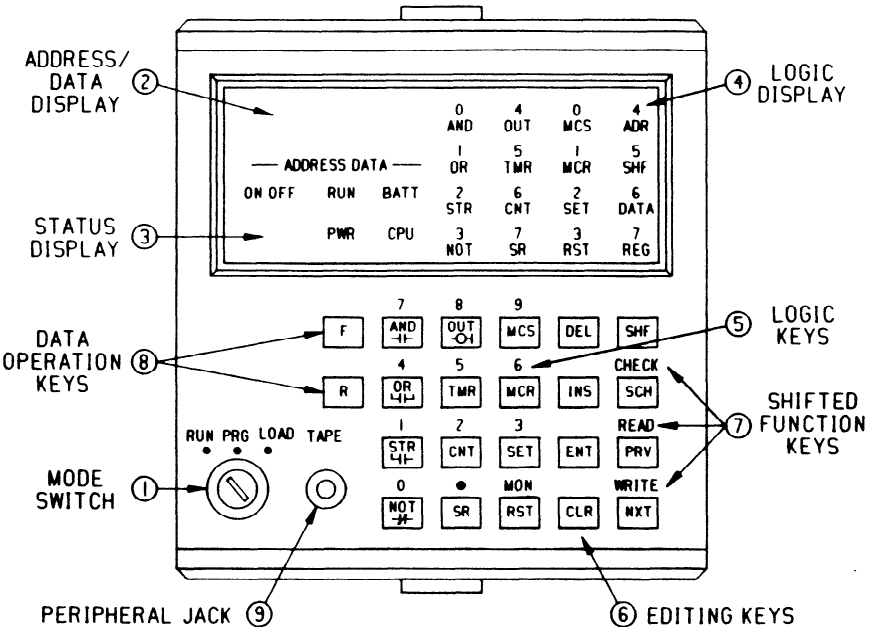

Figure 4-1. Programmer Features

Programmer Features

The programmer features shown in the illustration on the previous page are described in this section. The descriptions of the features are keyed to the numbers (1 to 8) next to each feature in the illustration.

1. Mode Switch

This is a three-position keyswitch used for selecting the operating mode of the PC. This switch can be repositioned at any time as necessary without disrupting AC power. The left position (RUN) allows program execution with outputs enabled. The CPU scans its stored logic and allows timer/counter and relay contacts to be displayed. However, in the Run mode, changes to the logic are not allowed. In the center (PRG or Program) position, new programs can be entered and previously entered logic can be altered; however, no solving of the logic is performed. The right (LOAD) position connects the programmer to an external device such as a tape recorder through the adjacent tape port. Logic is not solved while in the LOAD position.

WARNING

If a version A or B (IC610CPU101A OR IC610CPU101B) CPU IS installed, the Series One programmable controller will always power up in the run (operating) mode unless a programmer is connected and the programmer is in the program or load mode.

2. Address Data Display

This is a four digit display used to indicate either the address, in decimal format, of where the display is in the user program stored in the PC's memory or reference data used as a part of the logic. To indicate that addresses are being displayed, periods appear near the bottom and to the right of each digit (for example, 0.1.2.3.). The LED to the top right behind ADR will also be lit.

3. Status Display

These five LEDs are energized to indicate the following functions or status of the Series One:

ON/OFF	When in the Run mode, this LED indicates the status of discrete references (I/O, internal coils, and shift register stages). It is ON when a reference is energized and OFF when de-energized.
RUN	ON when in the RUN mode and CPU is solving logic.
BATT	ON when the voltage of the internal lithium battery, which is used for maintaining the program stored in CMOS memory during no-power conditions, is at a low level and should be replaced within 10 days - see Chapter 7. This LED is OFF when battery voltage is OK, or battery is disconnected.
PWR	ON when the internal power supply is producing DC power. If OFF the rack power supply should be checked - see Chapter 7.
CPU	ON when internal error checking has detected a fault in internal hardware - see Chapter 7.

The above four LEDs (RUN, BATT, PWR and CPU) duplicate the operation of the indicators on the CPU when the programmer is installed.

4. Logic Display

These sixteen LEDs are used to indicate the type of logic entered into memory. While being programmed, they reflect the logic selected by the user prior to actual entry into CPU memory. For definition of the first 12 LEDs functions, see key definitions under 5 below. The 4 LED's to the right have special functions as follows:

ADR	ON when display is indicating an address value. The address is displayed in decimal notation, beginning at 0000 and ending at the last address in the user program or a maximum of 1723 (maximum number of 16-bit words in memory is 1724).
------------	---

GEK-90842

- SHF** ON when operator has selected the Shift key and is an indication that future key selections will be based upon the upper key labels. Shift function will remain in effect until either the Enter or Clear key is selected.
- DATA** (Series One Plus only) On when monitoring the contents of a register and the Address/Data display contains the data (4-digit BCD value) in that register. The contents of 2 consecutive registers will be displayed.
- REG** (Series One Plus only) On when monitoring the contents of a register and the address of the selected register is displayed. The display can be alternated between REG and DATA by depressing MON.

These sixteen LEDs can also indicate the status of 16 consecutive I/O states when used with the monitor function discussed later in this chapter. The numerals above the alphabetical characters are used during this function.

5. Logic Keys

These twelve keys are used to select the required function and enter logic when in the Program mode. The upper labels are used to enter numerical values when preceded by the Shift key. Numerical values, when entered, are viewed in the Address Data display. The decimal point is used only for the entry of timer preset values in tenths of a second. The Monitor function will be discussed below as part of the Upper Case keys. The function of the lower or normal case labels on these keys is described in the following key discussion.

- AND** Places logic such as two contacts or two groups of contacts in series (see figure 4-2). Power flow must be possible through both elements before it will be passed to the next element.
- OR** Places logic such as two contacts or two groups of contacts in parallel (see figure 4-3). Power flow can be possible through either (or both) elements before it will be passed to the next element.

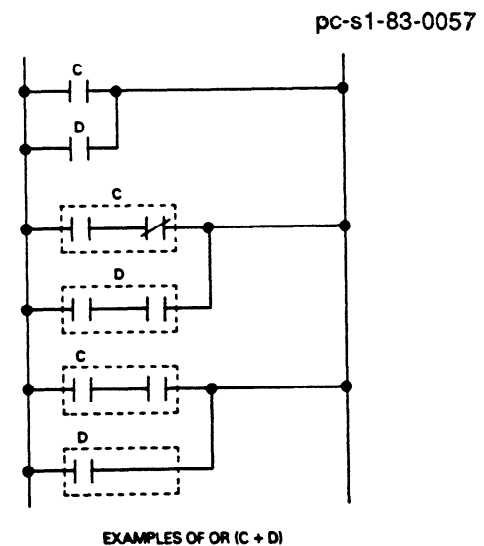
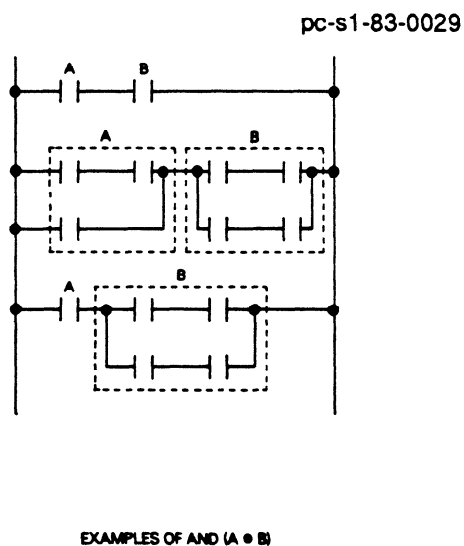

Figure 4-2. Series Logic (AND)

Figure 4-3. Parallel Logic (OR)

- STR** Begins (Starts) a new group of logic and stores current logic results into a Last In, First Out (LIFO) pushdown stack.
- NOT** Inverts the state of the referenced status to create a normally closed contact. NOT AND results in a normally closed series contact. NOT OR results in a normally closed parallel contact.
- OUT** Specifies the end of a string of logic by entering a coil. With a valid reference, such as OUT 19, this coil will reflect the output of the rung of relay logic by turning ON or OFF as dictated by the power flow. Outputs can be paralleled by entering additional OUT functions at the end of a rung of logic.

- TMR** Specifies a timer function to end a rung of logic. The timer requires a unique 6XX reference for storage. Two types can be programmed (seconds and tenths of seconds) depending upon the numerical preset (with or without decimal point) entered after the 6XX reference. For example, 0.9 or 9.0 seconds can be programmed, depending on the decimal point.
- CNT** Specifies a counter function to end two logic rungs. The two logic rungs required by this function are count and reset. Count, being the top rung of conditional logic. When all programmed conditions permit power flow, the counter will begin counting. The bottom rung is the reset rung and is programmed with the conditional logic required for resetting the counter. The counter also requires a unique 6XX reference for storage. Transition detection is a standard built-in function.
- SR** Specifies a Shift Register function to end three logic rungs (input, clock, and reset). The reference used with SR (for example, SR 410) is the first stage of this shift register. The last stage must be entered immediately after the SR and its reference. A shift register can contain a total of 128 steps or several shift registers can be programmed, each with a different number of steps, as long as the total of 128 steps is not exceeded.
- MCS** The MCS (Master Control Start) key specifies the beginning of a Master Control relay function. This provides an efficient method of programming for controlling large quantities of coils if a specific permissive condition is not satisfied.
- MCR** The MCR (Master Control Reset) key specifies the end of a Master Control relay function. A similar number of MCRs must be entered to terminate, one at a time, the Master Control Start functions entered. One MCR terminates only one previous MCS function.
- SET** Used with latches, shift registers, and coils. It specifies where latches are to be turned ON (set), shift register stages set to the ON state, or coils to be turned ON and not affected by internal reference 376 (disable all outputs).
- RST** Performs functions similar to the SET key for latches, shift registers, and coils, except it specifies when these references will be turned OFF (reset).

6. Editing Keys

These eight keys select the action required to modify either the stored logic within the CPU or the logic address being displayed. Those keys that can modify previously entered logic (that is, Delete and Insert) require a confirming key operation to ensure that the operation is to be executed. Thus, if they are accidentally depressed, the error can be corrected by depressing the CLR (Clear) key without actually affecting any entered logic. A description of each editing key is as follows:

- DEL** When logic is being displayed, this key (Delete) when included as the first keystroke of a two key sequence, will cause that single function to be removed (deleted) from the CPU memory. To be effective, after depressing Delete, the PRV (Previous) key must be depressed, which executes the delete operation.
- INS** This key (Insert) allows logic functions to be inserted between existing logic functions. The function or its address that is after the location at which the new function is to be placed, is displayed. Then the new logic is built followed by the Insert key (not the Enter key) and the confirming NXT (Next) key. The new logic that is inserted by this key sequence will be placed in memory immediately before the displayed function or address.
- ENT** The ENT (Enter) key is used to complete the entry of logic when initially building the CPU program or to replace an entire single word function. Logic functions are entered typically at the end of the existing logic.

GEK-90842

- CLR** The CLR (Clear) key, when selected, clears the programmer of previously entered commands. If error codes are displayed, this key will acknowledge the error and return the programmer to its normal (cleared) function. When monitoring a program, depressing Clear will cause the display to indicate the memory address in lieu of logic functions. When the key sequence CLR, SHF, 3, 4, 8, DEL, NXT is entered, the entire contents of memory will be cleared.

NOTE

This key sequence should be used with caution, be sure that you want to clear the entire program. Remember, if single functions or groups of functions are to be cleared, the DEL key, followed by PRV should be selected for each function to be cleared.

- SHF** This key (Shift) locks all other keys to their shifted (upper label) functions and causes the SHF LED to be lit in the display area. The shift operation is ended by selecting the keys Clear or Enter. The SHF key must precede a numerical key or a group of numerals before selecting the numerical keys. For example to enter an open contact with input reference 12 as the first contact in a rung of logic, the key sequence would be STR, SHF, 1, 2, ENT.
- SCH** This key (Search) allows the entire program to be searched for specific logic functions. The logic function is defined by the logic keys (without Enter), then Search is selected. The memory will be searched from the current location until either a match is found or all memory is searched. Successive depressions of this key will cause repeated searches with memory wrap-around. An unsuccessful search results in error code E99 being displayed.
- PRV** When displaying logic or monitoring I/O state, selecting the PRV (Previous)B key causes the previous logic function or I/O status to be displayed. Additional depressions of this key cause the display to decrement until memory address zero is reached.
- NXT** When displaying logic or monitoring I/O state, selecting the NXT (Next) key causes the next logic function or I/O status to be displayed. Additional depressions of this key cause the display to increment until the end of memory is reached.

7. Shifted Functions

The Shift key, when selected, causes most keys to change their function to those marked on the face of the programmer directly above the corresponding keys. Normal unshifted functions are as placed on the keys themselves. Most of the shifted functions are used when entering numerical values (digits 0-9 plus the decimal point). When entering a program, the unshifted functions must be selected first (AND, OR, NOT, OUT, TMR, etc.), then the SHF is selected to enter the numerical portion of the program. The use of the other four shifted functions are as follows:

- MON** When in the Run mode, this function allows the user to monitor the status of I/O references in two successive groups of 8. The specified I/O reference is used to select the first 8 references and the next group in numerical sequence is also shown to provide a total of 16 real time statuses. The specified reference should be the first reference in a group of 8, for example, specify 10 to monitor the I/O group 10 to 17. If a reference other than the first one in a group is specified, monitoring of the I/O will default to the first reference in the group. After the reference (for example 043) is entered and displayed (for example 040) as data, the status of the 8 references in that group (for example 040-047) are displayed by the first 8 LED's (AND, OR, STR, etc.) in the logic display.

The next 8 references (e.g. 050) are also displayed and their status is indicated by the last 8 LED's (MCS, MCR, SET, etc.). These 16 LED's will be ON or OFF as the I/O assigned to these references is energized or de-energized. As the I/O changes, the state of the LEDs changes.

To display another group of I/O references, the PRV or NXT key can be selected to decrement (40, 30, 20, etc.) or increment (50, 60, 70, etc.) the group number and its associated references. References up to 577 can be displayed; there is automatic wrap-around from 570 to 000 (NXT) or 000 to 570 (PRV). The current values of timers and counters can also be monitored by entering TMR or CNT, SHF, 6XX (timer or counter reference) followed by MON (the Monitor Key).

- WRITE** This function operates with an audio tape cassette recorder or certain other peripherals to effect a transfer of the CPU's logic to the peripheral. Connect the device to the tape port with the audio cable supplied with each programmer or peripheral. Set the mode switch to LOAD and turn the device ON. To begin the transfer, select the WRITE key. This starts the writing of the CPU logic onto the cassette or other peripheral. For more detailed information on transferring data to peripheral devices, refer to the discussion of each peripheral.
- READ** This function operates with the audio tape cassette recorder or other peripheral to load a CPU's memory from the cassette or other storage device. Connect the device to the tape port with the audio cable supplied with each programmer or peripheral. Set the mode switch to LOAD and select the READ key. To begin the CPU loading, turn the device ON. This starts the reading of the tape and the loading of the stored program into the CPU memory.
- CHECK** This function operates with the audio tape recorder or other peripheral to verify proper program transfer. After a transfer is made, it should be read back similar to the READ above; however, the CHECK key must be selected instead of READ. The Check operation does not alter either the CPU logic nor the data in the peripheral. A data compare is made between the two sources of information to ensure that there has been no error in the recording process.

8. Data Operation Keys

These two keys are used during entering the data operations when programming the Series One Plus PC. These keys have no effect when this programmer (Catalog no. IC610PRG105) is used to program a Series One PC. The function of each of these keys is described below.

- F** This key must be depressed before a 2-digit value corresponding to the data operation or Function to be performed (for example, F50, F62, F74, F82, etc.). A complete list of the data operations and their Function number can be found in Chapter 5, Programming. The shift key does not need to be depressed immediately before the function numbers as must be done when selecting other numerical values when programming a Series One or Series One Plus PC.
- R** This key serves a dual function, in that it is used to select either a data register or a Timer/Counter accumulated value register, or a group reference number when programming data operations. A register is operated on as a word (16 bits) in the Series One Plus PC. When a 3-digit data register reference (400 to 577) is specified, two consecutive 8-bit registers are actually selected to write data to or read data from. For example, if R followed by the reference 410 is entered, registers 410 and 411 are selected for that data operation. If R 6 1 0 were entered, the accumulated value register for the timer or counter assigned to that reference would be specified in a data operation. Unused T/C references, 600 - 673 can be used as data registers.

A register can be specified to contain a Timer or Counter preset value. In this case the register reference (R XXX) is specified immediately following the Timer or Counter reference when programming a Timer or Counter.

A group reference is a 1, or 2 digit reference corresponding to the first 1 or 2 digits of a group of 8 consecutive discrete references. These references can be real I/O points, internal coils, or shift registers. For example, if the R key followed by 37 is entered, the reference is to discrete points 370 through 377. If R 5 is entered, the reference is to I/O points 050 through 067 (050-057 and 060-067).

GEK-90842

9. Peripheral Jack

This is a serial port which allows connection of an audio cassette tape recorder to record (save) the program stored in user memory, verify the contents of a tape against the contents of user memory, and load a program stored on tape into user memory. It is recommended that programs entered into user memory be saved on tape, once they have been verified as being correct. Note that when recording a Series One Plus program on tape, the contents of the data registers are not saved.

Program Checking and Error Codes

When entering ladder logic programs with the programmer, the CPU automatically performs many checks on the data and operations selected by the programmer. Functions entered are checked for proper key sequence, proper range of references entered, etc. Errors detected during these checks are indicated in the data display by the letter E followed by a two digit code (01-99). The CPU also performs a partial program error check any time that the PC is switched to the RUN mode. After entering a program, a manual error check should be performed, which checks the entire program.

Table 4-1 summarizes the meaning of each error code, its cause, and possible methods of clearing the error. The use of the programmer to enter logic is documented in Chapter 5 as part of programming. However, there are many other valuable functions it provides which are shown in the following table:

Table 4-1. Error Code Definitions

Code	Applicable Mode			Significance	Cause	Corrective Action
	Run	Prog	Load			
E1	X	X	X	Incorrect Operation	Operator attempted to perform illegal operation such as changing program in RUN mode.	Examine operation. Depress CLR. Reinitiate proper function.
E2	X			Fault in Program Structure. Series One.	CPU has detected error in program when placed into RUN mode. Example: Input module reference used as coil	Go to Program mode. Depress CLR. Address of faulty logic will be shown. Depress NXT to display content.
E2	X			Fault in Program Structure. Series One Plus.	CPU has detected error in program when placed into RUN mode. Example: Input module reference used as coil.	Go to Program mode. Depress CLR-SCH-CLR. Address of faulty logic will be shown. Depress NXT to display content.
E3	X			Stack Capacity Exceeded	More than eight status levels attempted to be stored in pushdown stack.	Go to Program mode. Depress CLR. Programmer will display location of first 9th STR error. Examine logic and reprogram as necessary.
E5	X			Duplicate Coil Reference	Coil (output, internal, timer, or counter) used as an OUT more than once.	Go to Program mode. Depress CLR. Programmer will display location of second coil of pair using same reference. Enter another coil reference.

Table 4-1. Error Code Definitions - Continued

Code	Applicable Mode			Significance	Cause	Corrective Action
	Run	Prog	Load			
E6	X			Incomplete Master Control	More MCR references than MCS in program.	Go to Program mode. Depress CLR. Programmer will display first unmatched MCR. Correct program by deleting MCR or adding MCS.
E7	X			Incomplete Counter or Shift Register.	All control lines not provided to one or more Counters and/or Shift Registers.	Go to Program mode. Depress CLR. Programmer will display errant function. Add required reset, clock or clear lines.
E8		X		Incorrect Operation.	Operator attempted to write instruction on second word of a 2-word instruction.	Depress CLR.
E9	X			Incomplete Logic.	Relay ladder line not connected to coil; relay contact(s) left incomplete or hanging.	Go to Program Mode. Depress CLR. Programmer will display first unfinished logic element. Add logic to tie this element into stored logic, or delete element(s) to remove incomplete logic.
E11		X		Memory Full.	Operator attempting to add logic to CPU already at limit.	Depress CLR. Restructure program so that logic limits will not be exceeded.
E21	X	X		Parity Failure.	CPU has detected a fault in the parity structure of its internal memory.	Go to Load Mode. Depress CLR. Reload memory from previously recorded tape or clear entire memory and reload manually. If BATT light not ON and fault cannot be cleared, replace CPU module.
E25			X	Faulty Comparison.	External device such as tape cassette has content that does not agree with CPU memory.	Depress CLR. Verify correct program number or tape. If correct, either re-record tape or reload CPU.
E28			X	Weak Record Signal.	Playback Signal level, such as from tape recorder, is below acceptable level.	Adjust volume level on tape recorder or other peripheral device. If ON steady for extended period of time, restart function to obtain reliable operation.
E99	X	X		Unsuccessful Search.	Search function has reviewed all memory and has not located required.	Depress CLR. To cause an additional search, re-enter function and restart.

Operation Sequences

An understanding of the basic PC operation sequences is necessary in order to effectively and efficiently enter ladder diagram programs. You should be familiar with the use of each key, alone and in sequence

GEK-90842

with other keys. The programmer is an excellent tool for program entering, editing and monitoring. Table 4-2 lists the various operations, the keystrokes required to enter those operations, and the mode or modes in which the operation can be performed. Each of the modes is indicated by a letter; R (RUN), P (PROGRAM), or L (LOAD).

Table 4-2. PC Operation Sequences

Operation	Keystrokes or Operation Sequence	MODE		
		R	P	L
Insert or Remove Key		X		X
Clear all user memory	CLR SHF 3 4 8 DEL NXT		X	
Display present address	CLR	X	X	
Display present function	NXT	X	X	
Next function	NXT(After previous keystroke)	X	X	
Previous function	PRV	X	X	
Go to address 0000 in program memory	SHF NXT	X	X	
Go to specific address	SHF (address) NXT	X	X	
Go to next address	After previous entry NXT	X	X	
Clear displayed function	CLR	X	X	
Search for a specific function	(Function) SHF (Ref. No.) SCH NXT	X	X	
Search for a specific reference number	SHF (Ref. No.) SCH NXT	X	X	
Insert function before the displayed function (or address)	(Function) SHF (Ref. No.) INS NXT		X	
Cancel insert	CLRSHF INS		X	
Delete a function	(address) DEL PRV		X	
Check program for errors. If no error detected, the next available address is displayed.	CLR SCH	X	X	
Turn Timer/Counter ON Turn Timer/Counter OFF	TMR or CNT SHF 6XX SET TMR or CNT SHF 6XX RST	X		
Change preset value of a Timer or Counter	SHF (preset value) ENT	X		
Monitor ON/OFF status of a group of 16 consecutive references (I/O, internal coils, Shift Register coils)	SHF (Beginning Ref. No.) MON	X		
Monitor Timer or Counter accumulated value	SHF (T/C No.) MON To monitor the previous or next T/C enter, PRV or NXT	X		
Monitor ON/OFF state of any coil or contact	The ON OFF LED turns ON or OFF to indicate the state of the displayed reference.	X		
Force a reference ON (will be overridden by user logic)	SET SHF (Ref. No.) ENT Reference can be Input, Output, Shift Register, Timer or Counter	X		

Table 4-2. PC Operation Sequences - Continued

Operation	Keystrokes or Operation Sequence	MODE		
		R	P	L
Force a reference OFF (will be overridden by user logic)	RST SHF (Ref. No.) ENT	X		
Enter a function into program memory	(Function) SHF (Ref. No.) ENT		X	
Edit a program	Same as above. Select address and enter change		X	
Transfer data to tape	(Optional program ID) SHF WRITE			X
Load program memory from tape	(Optional program ID) SHF READ			X
Verify data on tape or in PROM writer RAM against program memory	(Optional program ID) SHF CHECK			X
SERIES ONE PLUS ONLY				
Monitor contents of Data Registers (1)	R (Register Ref) SHF MON	X		
Monitor next register	NXT	X		
Monitor previous register	NXT	X		
Enter or change the contents of displayed register. A 4 digit BCD value can be entered (16-bits).	SHF XXXX ENT When the data contents are displayed, this sequence will overwrite the current contents of the register	X	X	
Enter or change a password (2) (3)	CLR SHF 9876 DEL SHF XXXX ENT NXT	X	X	
Log in sequence (3)	CLR SHF 5678 DEL SHF (Password) ENT NXT	X	X	
Log out sequence (3)	CLR SHF 1234 DEL NXT	X	X	

1. When the MON key is selected, the ADDRESS DATA display shows the address of the specified register. To display the data contents of the register, depress the MON key again.
2. 9876 is a fixed sequence. The password (XXXX) can be any numerical value between 0001 and 9999. The value 0000 is equivalent to no password. All programmer functions are operable when the password is 0000.
3. Password information also applies to the Series One Model E PC.

The above table provides a convenient reference to the programmer keystrokes required for the various PC operations. A more detailed description of each operation is provided on the following pages or in Chapter 5, Programming.

Monitor CPU Logic - This sequence of operation provides the steps required in order to observe the contents of user memory. You can either step forward or backward in user memory. With the Programmer installed and the mode switch in the Run or PRG (Program) position, observe or perform the following actions:

1. The programmer will display address zero indicated by four zero digits in the display with decimal points to the right of each digit (0.0.0.0.), and the ADR LED lit.
2. Depress the NXT key, the logic content of memory location zero will be shown (beginning of memory or scan).

GEK-90842

3. Successive depressions of the NXT key will cause the programmer to step through the stored program in the order that the program is scanned, from address 0.0.0.0. to the last address in the program. At any time, the CLR key can be depressed to display the address of the logic then being viewed.
4. An additional depression of the NXT key will restore the display to the logic content.
5. At any time, depressing PRV will cause the logic of the previous (closer to zero) memory location to be displayed.
6. Successive depressions of PRV will cause the programmer to step backwards through the stored program in reverse of the order that the program is scanned. At location 0.0.0.0., PRV has no effect.
7. If by successive depressions of NXT, the end of the actual program is passed, the display will show End. With each successive selection (with the NXT or PRV keys) of an unprogrammed or empty memory word, the address of the new location will flash in the display for 1/4 to 1/3 of a second prior to going to End.

Search CPU Logic - In the event that you wish to quickly find a particular logic element (programming step) in user memory, this sequence of operation allows you to do so. After installing the programmer, with the mode switch in the RUN or PRG position, observe or perform the following actions:

1. The programmer will display address zero indicated by four zero digits in the display, decimal points to the right of each digit (0.0.0.0.), and the ADR LED lit.
2. Enter the logic function whose location is to be searched for. For example, select AND, SHF, 1, 0, 5 (AND 105). Do not select ENT key.
3. Select the SCH key to begin the search. If the logic function is not found, error code E99 will be displayed.
4. If a match is found, the display will indicate the first memory address containing the desired function. Depressing NXT will cause the logic at that address to be displayed.
5. Successive depression of SCH, while the memory address is being displayed, will cause additional searches to occur from the current location.
6. As long as one match is found, the search will not stop at the end of memory, but will continue with memory address zero until a match (possibly the same location) is again detected.
7. To find the first empty memory word, depress CLR to obtain an address location. Then select SCH (search for zero content) to begin the search for the first available location.

Alter One Logic Element - This sequence of operation allows you to change the contents of a particular location in user memory. After installing the programmer, place the mode switch in the PRG position. Observe or perform the following actions:

1. The programmer will display address zero indicated by four zero digits in the display, with decimal points to the right of each digit (0.0.0.0.), and the ADR LED lit.
2. Move the display to the element to be altered using the NXT or PRV key or Search function.
3. Enter the new logic element, for example: OR, SHF, 2, and 5 (OR 25).
4. Select the Enter (ENT) key to cause the change to occur. The new logic element you have entered will take the place of the previous logic at that memory location. The next address will be automatically displayed.
5. If the new element is not to be entered or an error has been made in its construction, depressing the Clear (CLR) key will cancel the new logic and return the display to the address of the examined element.

Delete One Logic Element - This sequence of operation allows you to remove one logic element from the program in user memory. After installing the programmer, place the mode switch in the PRG position. Observe or perform the following actions:

1. The programmer will display address zero indicated by four zero digits in the display, with decimal points to the right of each digit (0.0.0.0.), and the ADR LED lit.
2. Move the display to the element to be deleted using the NXT or PRV key or the Search function.
3. Select the DEL key. Notice that the Address/Data display has a small "d" in the left digit of the display.
4. To confirm that the Delete operation is to be executed, select the PRV key. The next address will be displayed after the Delete is performed. The remaining user logic will automatically move back one address location (nearer to 0.0.0.0.) to fill the empty memory.
5. To cancel the Delete operation, select the CLR key (before selecting DEL). The display will revert to the element being considered for deletion.

Clear All Memory - This programming sequence should only be used when the entire contents of logic memory are to be cleared. After installing the programmer, place the mode switch in the PRG position. Observe or perform the following actions:

1. The programmer will display address zero indicated by four zero digits in the display, with decimal points to the right of each digit (0.0.0.0.), and the ADR LED lit.
2. Select the key sequence CLR, SHF, 3, 4, 8.
3. Select the DEL key; the display will change to.
4. To execute the clear function and cause all logic elements to be removed from user memory, depress the NXT key.
5. To cancel the clear function, the CLR key can be depressed before depressing NXT.

Insert One Logic Element - This sequence of operation allows you to insert one logic element between two existing program steps in the use program. After installing the programmer, place the mode switch in the Program position. Observe or perform the following actions:

1. The programmer will display address zero indicated by four zero digits in the display, with decimal points to the right of each digit (0.0.0.0.), and the ADR LED lit.
2. Move the display to the element that will be after the location at which the new element is to be entered. This can be done by using the NXT or PRV key or the Search function.
3. Enter the new logic element, for example; AND, SHF, 1, 0, and 4 (AND 104).
4. Select the Insert (INS) key to cause the change to occur. Notice that the address display has a small "i" in the left digit of the display.
5. A confirming keystroke is required to ensure that the insert action by the operator is valid. To confirm the insert, select the NXT key. After the insert is performed, the display will show the address of the next logic element.

Monitor I/O Status - This operation sequence allows you to monitor the status (ON or OFF) of references. A total of 16 I/O references can be monitored at any one time, beginning with the lowest address in the group with the reference selected by the operator. Each reference is within a group of 8 references. The I/O status of the group containing the selected reference, plus the next higher group of 8, is displayed. After installing the programmer, place the mode switch in the RUN position. Observe or perform the following actions:

1. The programmer will display the address zero indicated by four zero digits in the display, with decimal points to the right of each digit (0.0.0.0.), and the ADR LED lit.
2. Enter any reference to be monitored. For example, to monitor the real time status of references 020-027, or any one reference within that group, the following keys can be selected: SHF, 2 and 0.

GEK-90842

3. Select the Monitor function (MON). Note that the shift is still in effect (selected in previous step) causing the RST key to select the monitor function.
4. The display will revert to]-] followed by the lowest reference (e.g. 020) in that group. The I/O references can be for a 4, 8, or 16 point module. If the module is a 4-point module, the status of the first 4 I/O points are real world outputs and their operating status will be displayed. The 4 higher references cannot be used as real world outputs, but can be assigned to internal coils. The 4 monitor LEDs normally assigned to the 4 higher references in this group will always be OFF.

The status of an 8 point module (for example, 030 to 037) is indicated by the first 8 LED's (AND, OR, STR, ... SR) and the next module's status, if an 8 point (for example, 040-047) will be indicated by the last 8 LEDs (MCS, MCR, SHF....7). In the case of a 16-point module, the status of all 16 points will be consecutively displayed.

5. Depressing the NXT or PRV keys will cause the address display to increment or decrement to the next or previous group of 8 statuses or module, if in an expansion rack. All discrete references can be examined. The display returns to zero after the highest reference has been examined.

Monitor Timer or Counter Status - This operation sequence allows an operator to monitor the current accumulated value of a timer or counter. After installing the programmer, place the mode switch in the RUN position. Observe or perform the following actions:

1. The programmer will display the address zero indicated by four zero digits in the display, with decimal points to the right of each digit (0.0.0.0.), and the ADR LED lit.
2. Enter the timer or counter reference to be monitored. For example, to monitor the operating status of timer 601, enter SHF, 6, 0, 1. If a counter had been assigned reference 601, you would then be monitoring the status of counter 601. The valid references for timers or counters are 600 to 677. References 674, 675, 676, and 677 are reserved for use with the Thumbwheel Interface unit (Series One or One Plus) or the Timer/Counter Setpoint Unit (only for Series One Plus). Remember, each valid reference can be assigned to only 1 timer or 1 counter.
3. Select the Monitor function (MON). Note that the shift selected in the previous step is still in effect causing the RST key to select the monitor function. If the selected reference is not used in the program, error code E01 will be displayed.
4. The display will contain the current content (accumulated value) of the selected timer or counter. Timer values will be displayed in tenths from 000.1 up to 999.9 and counter values will be 0001 to 9999. The Logic Display will also show the two least significant digits of the timer or counter reference (for example, 01 for timer or counter 601).
5. The NXT and PRV keys move the display to adjacent timer or counters. Any timer or counter not actually used in the logic cannot be displayed.

Display a Specific Address - This operation sequence allows you to select and display a specific memory address (location) and the logic content of that address. After installing the programmer, place the mode switch in the RUN or PRG position. Observe or perform the following actions:

1. The programmer will display the address zero indicated by four zero digits in the display, with decimal points to the right of each digit (0.0.0.0.), and the ADR LED lit.
2. Enter the memory address to be observed. For example, if the logic contained in address 36 is to be observed, SHF, 3 and 6 would be selected.
3. The NXT key is then selected and the display will contain the selected address. To display the content of this memory address, the NXT key is depressed a second time.
4. At any time, selecting SHF then NXT will cause the display to go to address 0.0.0.0.

Monitor Data Register Contents (*Series One Plus only*) - This operation sequence allows an operator to monitor the current contents of any data register. After installing the programmer, place the mode switch in the RUN position and perform the following actions:

1. The programmer will display the address zero indicated by four zero digits in the display, with decimal points to the right of each digit (0.0.0.0.), and the ADR LED lit.
2. Enter the reference for the data register to be monitored. Valid data register references are 400 through 577 and 600 through 673. For example, to monitor the contents of data register 452, enter the key sequence R 4 5 2 MON.
3. The display will contain the address of the selected data register.
4. To display the contents of the selected data register, depress the MON key a second time. The display will now contain the current contents (4-digit BCD value) of the selected register.
5. The NXT and PRV keys move the display to adjacent data registers.

Change Contents of a Data Register (*Series One Plus only*) - This operation sequence allows an operator to change the current contents of any data register. After installing the programmer, place the mode switch in the RUN position and perform the following actions:

1. The programmer will display the address zero indicated by four zero digits in the display, with decimal points to the right of each digit (0.0.0.0.), and the ADR LED lit.
2. Enter the reference for the data register to be monitored, following the steps in the previous operation.
3. After depressing the MON key a second time and the current contents of the data register are displayed, the contents may be changed if desired.
4. To change the current contents of the displayed data register, enter the sequence SHF XXXX ENT, where XXXX is a 4-digit BCD value having a valid range from 0000 to 9999. The new value entered will write over (replace) the value originally displayed.

Enter or Change a Password (*Series One Model E and Series One Plus*) - This operation sequence allows an operator to enter a password or change a previously entered password. When a password is entered, all programmer functions are disabled, except for the monitor functions. This prevents unauthorized access to the program in a Series One Plus PC. After installing the programmer, place the mode switch in the RUN or PRG position and perform the following actions:

1. To enter a new password or change a previously entered password, use the following key sequence:
CLR SHF 9876 DEL SHF XXXX ENT NXT
2. 9876 is a required sequence. Your password (XXXX) can be any numerical value from 0001 through 9999. The value 0000 is equivalent to no password, all programmer functions are operable when the password is 0000. If you do not have a requirement for password security, use 0000.

To have access to all programmer functions when a password is in effect, a LOG IN sequence must be entered by the operator. After performing any necessary operations with the programmer, the operator must then enter a LOG OUT sequence to prevent any unauthorized access to the program. The LOG IN and LOG OUT sequences are shown below.

Access to Programmer Functions with Password in Effect (*Series One Model E and Series One Plus*) After installing the programmer on a Series One Plus PC having a password in effect, place the mode switch in the RUN or PRG position and perform the following actions:

1. To LOG IN, enter the key sequence:
CLR SHF 5678 DEL SHF XXXX ENT NXT
2. The numerical value, 5678 is a required entry. XXXX is the password that had been previously selected by the operator.

GEK-90842

3. The operator can now monitor or change the program as required. When not using the programmer, the operator should then LOG OUT to return the programmer to password security.
4. To LOG OUT, enter the following key sequence.

CLR SHF 1234 DEL NXT

5. Verify that the programmer functions have been disabled.

NOTE

If the user should for any reason forget the password entered into the PC, use of most programmer functions would not be possible. If this should happen, contact the GE Fanuc Automation service center in Charlottesville, Virginia for assistance.

Forcing References - The operation sequences described in this paragraph allow you to force an Input, Output, Shift Register, Timer, or Counter reference either on or off. Forcing the state of I/O references provides a convenient method of testing the operation of field devices and debugging the logic in the user program. If an input or output is forced on or off, it will remain in the forced state for 1 scan of the CPU. The programmer must be in the RUN mode to force any reference. After installing the programmer, place the mode switch in the RUN position. Use the following steps to force references.

1. The programmer will display address zero indicated by four digits in the display, with decimal points to the right of each digit (0.0.0.0.), and the ADR LED lit.
2. Enter one of the following sequences to force a reference either on or off as required:
 - To force a specific reference ON, enter the sequence: SET, SHF, XXX (Reference), ENT
 - To force a specific reference OFF, enter the sequence: RST, SHF, XXX (Reference), ENT
3. Repeat the above operation for other references to be forced.

WARNING

When forcing input points with the set or rst sequence, the actual state of the input may be overridden. If the forced set or rst occurs in the user logic program before the input is checked in the same i/o scan, the set or rst state will take precedence and could cause an output to be turned on or off at the wrong time.

Operation With Peripheral Devices

Several peripheral devices are available for use with a Series One or Series One Plus PC. The Programmer is required for operation with the tape recorder, when recording user programs. The tape recorder connects to the Programmer through the Programmer's tape port. The tape port is located to the right of the mode switch and is labeled TAPE. The rest of this chapter describes the operation of these peripherals, which are listed below:

Audio Tape Recorder	Various models
Printer Interface Unit	Catalog Number IC610PER151
PROM Writer Unit	Catalog Number IC610PER154

Tape Recorder Operation

Most audio tape recorders with auto-level control can be used with a Series One or Series One Plus PC. It is recommended that the recorder also be equipped with a counter to allow multiple programs to be recorded on tape. Units such as General Electric model 3-5148 have been tested and found fully compatible with the Series One family of PCs. This recorder is packaged with an interface module (not

required for the Series One or Series One Plus PCs) and can be ordered as Catalog Number 3-5156. The tape recorder allows three functions to be performed: (1) record a program onto tape, (2) load a CPU or peripheral from tape, and (3) verify the content of a tape. The operation of each of these functions is described below in a step-by-step manner. All logic memory is recorded on tape.

Tapes created on Series One, Series One Model E or Series One Plus PCs can be loaded into any Series One, Series One Model E, Series One Plus or Series One Plus 3.7K PC. Tapes created on the Series One Plus 3.7K PC can only be loaded into another Series One Plus 3.7K PC.

A 2.5 foot (0.75 meter) audio cable (Catalog number IC610CBL151), which is gray with a red tracer, is supplied with the programmer. This cable is used only with a tape recorder and connects it to the tape port on the programmer.

Recording A Program

1. Install the Programmer and apply AC power to the PC.
2. Turn the mode switch on the Programmer to the LOAD position.
3. Apply AC power to the tape recorder. Verify presence of the write protect tab on a cassette and insert the cassette. If the write protect tab is not in place, data entered on the tape may be inadvertently erased.
4. Adjust the tone control to its highest position.
5. Connect the Programmer (TAPE port) to the tape recorder (MIC input) with the 2.5 ft. (0.75 m) audio cable (gray with red tracer).
6. Rewind tape to the beginning or to the desired record position if multiple programs are to be placed on one tape. Programs require approximately 1.5 minutes (700 words), 4 minutes (1724 words) or 8 minutes (3.7K words), as applicable, of tape per program.
7. For identification of a program, if desired, enter a four digit number (0000-9999) on the Programmer. When tape is accessed later to load the CPU, this number can be used to identify the correct program prior to altering CPU data. If a program number is not as expected, the operator can terminate the load operation and get the correct tape without loss of existing program nor delay incurred by loading a wrong program. However, this identification number is optional.
8. Begin the tape recorder operation by depressing the RECORD button (and PLAY if required by the tape recorder).
9. Depress the WRITE key on the Programmer. The record operation will now begin.
10. If after following all instructions, reliable operation cannot be obtained, try operating the recorder with batteries.
11. When the record is complete, the Programmer will display End in the Address/Data display and the ON/OFF LED will be off. Stop the recorder and note the counter position so that the amount of tape used for that program can be determined.
12. Depress the CLR (Clear) key on the Programmer to end the record operation.
13. It is recommended that the tape be rewound to where the record began and that the Verify operation described below be performed to ensure data integrity.

Verifying A Program

1. Install the Programmer and apply AC power to the PC.
2. Turn the mode switch on the Programmer to the LOAD position.
3. Apply AC power to the tape recorder and insert the cassette containing the program to be verified.

GEK-90842

4. Adjust the tape recorder's volume control to the maximum setting. Adjust the tone control to its highest setting.
5. Connect the Programmer (TAPE port) to the tape recorder (EAR input) with the audio cable (gray with red tracer).
6. Rewind the tape to the beginning of the previously recorded program. The tape can also be on the blank area prior to the program, but not on another program. Enter the program identification number (if previously recorded).
7. Depress the CHECK key on the Programmer to select the verify operation.
8. Start the tape recorder by depressing the PLAY button. The verify operation now begins.
9. Any errors detected during the verify operation are indicated by an error code being displayed on the Programmer's Address/Data display. Error code E21 indicates that the tape has an internal parity error. E25 indicates a mismatch between the content of the tape and the CPU logic memory. E28 indicates that the play level is wrong and the verify operation should be stopped, volume adjusted, and the operation restarted (from step 6 above).
10. Setting of the volume control is critical for proper operation. The error code displayed for an incorrect (low) volume control setting is E28. Figure 4-4 illustrates the area of the volume control available for a proper setting.

pc-s1-83-0065

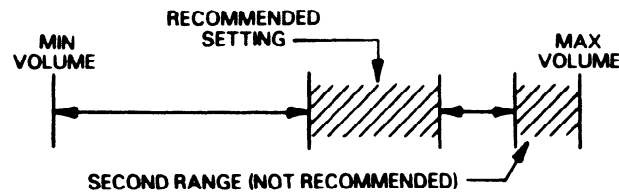

Figure 4-4. Volume Control Range Setting

With some recorders, there are two ranges where the signal level appears to be acceptable, one near the middle and one near maximum volume. The setting near maximum volume should not be used. The CPU will indicate that it is acceptable; however, an unacceptable amount of clipping distortion may occur in this area with some recorders.

11. Find the correct position for the mid-range of the acceptable volume control during the beginning or header portion of the tape. Some experimenting may be necessary. The duration of time for the header is about 12 seconds. It is important to choose the lower of the two ranges for the volume control setting if they both exist (see 10 above). For the recommended GE Fanuc Automation recorder this is at about 80% of the full maximum setting. Mark the proper setting with paint or some other method of identification.
12. If the volume control has been correctly set before the end of the header, the programmer display will be blank, and the lower right number 7 LED will turn on dimly. Before the end of the header the LED will turn off. A few seconds later, F will be displayed, indicating that the program has been found.
13. During the adjusting process in 11 above, the data from the tape may not be valid if the adjustment is not performed quickly enough. The tape loading should be repeated with the correct volume control setting. To clear the CPU to restart the loading, it is necessary to either power-down the CPU or remove the Programmer from the CPU, then reattach and depress the Clear key.

14. When the verify is complete without error, the **Programmer** will display End in the Address/Data display.
15. Stop the recorder and depress the CLR (Clear) key on the Programmer to end the **verify** operation.
16. The **verify** operation will require approximately the same time as the record operation.

Loading A Program

1. Install the Programmer and apply AC power to the PC.
2. Turn the mode switch on the Programmer to the LOAD position.
3. Apply AC power to the tape recorder and insert the cassette containing the required program.
4. Adjust the volume control to the setting determined during the verify operation. Adjust the tone control to its highest setting.
5. Connect the Programmer (TAPE port) to the tape recorder (EAR input) with the audio cable (gray with red tracer).
6. Rewind the tape to the beginning of a previously recorded program. Tape can also be on the blank area prior to the program, but not on another program. Enter the program identification number (if previously recorded).
7. Select the READ key on the Programmer to establish the load operation.
8. Start the tape recorder by depressing the PLAY key. The load operation now **begins**.

If the CPU detects a program number different than the one **entered in** step 6, the programmer will beep and the display will show PA .

9. If the wrong program has been selected, the load operation can be aborted by stopping the recorder and powering-down the CPU or remove the programmer **from** the CPU, then reattach and depress the CLR key.
10. Any errors detected during the load operation are indicated by an error code being displayed on the Programmer's Address/Data display. Error code E21 indicates the tape has an internal parity error. A steady E28 indicates the play level is wrong and the load should be stopped, volume adjusted, and the operation restarted (step 6 above).
11. When the load is complete with no errors, the Programmer will display End in the Address/Data display and the ON/OFF LED will be off. Stop the recorder and depress the CLR (Clear) key on the Programmer to end the load operation.
12. The load operation will require approximately the same time as the record operation.

Printer Interface Unit

The Printer Interface Unit (catalog number **IC610PER151**) provides an interface between a Series One or Series One Plus PC and a printer for the purpose of providing a convenient means of obtaining a hard-copy printout of the program residing in the PC's user memory. It can also be used with a Series One Junior PC. The format of the printout is switch selectable and can be either Boolean (mnemonic) or ladder diagram format. Many readily available, inexpensive printers can be used with the Printer Interface Unit.

A 6' (**2m**) Printer Interface cable and an external power supply cable are included with the Printer Interface Unit. Printer Interface Unit Specifications are listed below in table 4-3

GEK-90842

Table 4-3. Printer Interface Unit Specifications

Operating Temperature Storage Temperature Humidity (non-condensing) Required Operating Power	0° to 60° C (32° to 140° F) -10° to 70° C (14° to 158° F) 5 to 95% +5 V dc + 5%, 300 mA (minimum) (Supplied either internally from the CPU or from an external power supply)
Dimensions Weight Printer Interface Printing Capacity (maximum)	5.7" x 4.7" x 1.5" (145 x 120 x 38mm) 11.68 oz (330 g) Centronics (Parallel) Ladder Diagram Listing 13 contacts and 1 coil per line 16 lines per page Boolean Listing 200 steps per page (4 lines with 50 steps in each line). 700 steps maximum

Table 4-4 lists the requirements that a printer must meet for use with the Printer Interface Unit.

Table 4-4. Printer Requirements

<ul style="list-style-type: none"> • Must have a Centronics interface • Able to generate ASCII character code 7CH (Hexadecimal) as a '/' (slash). • Must respond to control codes: OE H (SO) - Expanded print ON OF H (SI) - Compressed print ON 12 H (DC2) - Compressed print OFF 14 H (DC4) - Expanded print OFF • Must be capable of printing 132 columns; however, if an 80 column printer can respond to the SI (OF H) control code to allow 132 or more characters per line, it can be used. This type of printer, when used with the Printer Interface Unit, will print compressed characters. Choice of normal (132 column) or compressed (80 column) print is switch selectable. • The following printers have been tested for operation and can be used with the Printer Interface Unit. <ul style="list-style-type: none"> General Electric Personal Computer Printer, model 3-8100 Epson model RP-100 Hewlett Packard Thinkjet, model HP 2225C IBM Personal Computer Graphics Printer Seiko model GP-500
--

Hardware Description

The **Printer Interface Unit** is a compact unit that attaches to the **Series One** or **Series One Plus** PC. **Electrical and physical connections to the PC** are made through a **26-pin** connector located on the back of the **Printer Interface Unit**. The **Printer Interface Unit** is attached to the PC by placing its **26-pin** connector directly over the mating connector on the PC and gently pushing down on the unit until it is securely in place.

Connection from the **Printer Interface Unit** to the selected printer is made through the **Printer Interface Cable, IC610CBL152** to a **24-pin** connector on the front of the unit. Power to the unit can be supplied directly through the rear panel connector from the CPU power supply or from an external power source

capable of supplying **+5 V dc @ 300 mA**. The power source, either internal (**INT**) or external (**EXT**) is selected by a **2-position** switch located on the rear panel. Connection to an **external** power source is made through a **3-wire** cable supplied with the Printer Interface Unit.

The sequence for operation of the Printer Interface Unit is initiated by depressing pushbutton switches on the front panel. Two indicator lights on the **front** panel provide a visual status of the Printer Interface Unit operation. There are also 2 indicators that provide operating status of the PC. Figure 4-5 is an illustration of the Printer Interface Unit showing the features mentioned above.

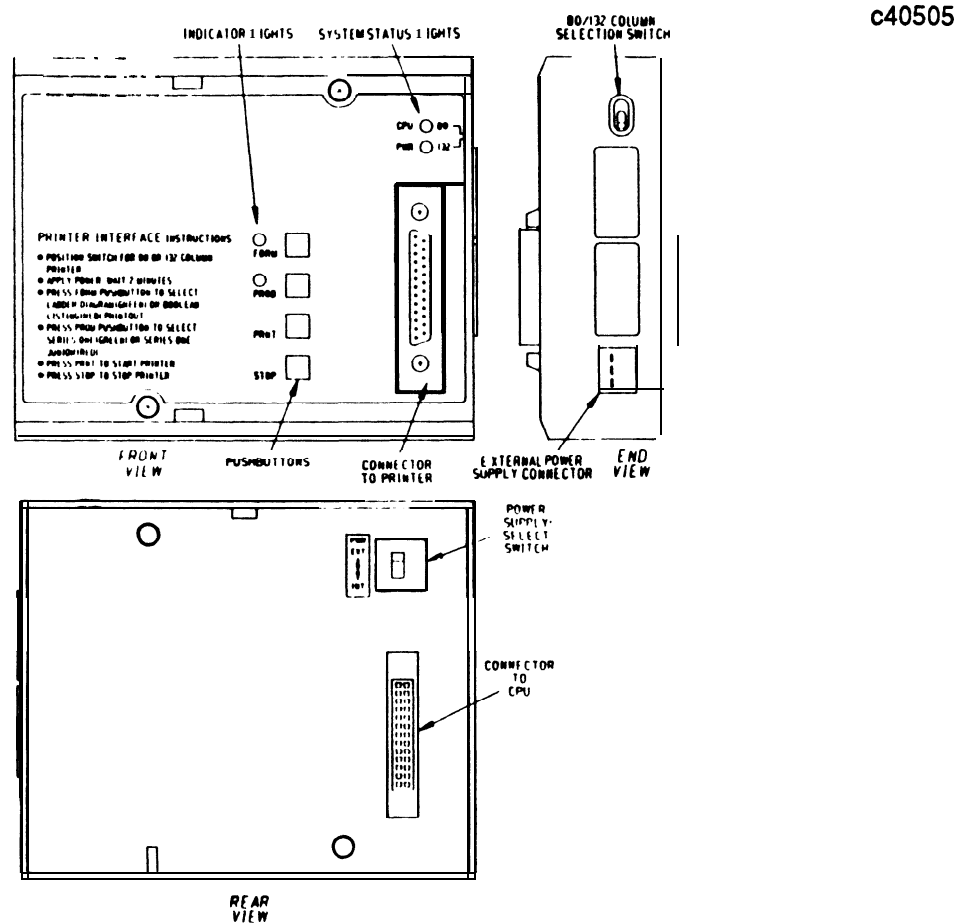

Figure 4-5. Printer Interface Unit

Hardware Features

The Printer Interface Unit front panel has two **LEDs** located in the upper right corner used for visual indication of system status. The purpose of the indicators is described below.

- | | |
|-----|--|
| CPU | The red CPU LED is an indication of the operating status of the CPU in the PC. This is identical to the CPU LED on the PC. |
| ON | CPU failure has been detected. |
| OFF | CPU operation is normal. |
| PWR | The green PWR LED is an indication of the status of dc power being supplied to the Printer Interface Unit. |
| ON | If power is being supplied by the Series One or Series One Plus internal power supply, this indicates that +5 V dc is being properly produced by the supply. If the Printer Interface Unit is being powered from an external source, the +5 V dc being supplied is within the specified tolerance. |

GEL90842

OFF 5 V dc not being supplied or not in tolerance.

The **24-pin** connector located on the lower right of the front panel, provides a connection from the Printer Interface Unit to the selected printer through the Printer **Interface** cable, **IC610CBL152**.

Immediately to the left of the connector are **4** pushbuttons used to initiate operation of the Printer Interface Unit to get a hard copy printout. There are also **2 LEDs** used as status indicators during the set-up procedure.

FORM This pushbutton is used to select the format of the printout, either a ladder diagram or Boolean listing of the user program. The pushbutton is an alternate **function** switch. Each time it is depressed, **the** selected **printout format** will change.

As the pushbutton is depressed, the color of the LED will **alternate** between green and **red**. The LED, when **green**, indicates a ladder diagram printout; when red, indicates a Boolean listing printout.

PROD This pushbutton is also an alternate function switch. Each time it is **depressed**, either a Series One Junior PC or the Series One/Series One Plus PC is alternately selected as the program listing **source**. The **selection** must agree with the PC to which the **Printer** Interface Unit is attached.

As this pushbutton is **depressed**, the color of the LED **will alternate** between **green** and **red**. The LED, when red, indicates selection of Series One Junior, when green, indicates selection of Series **One/Series One Plus**.

PRNT When depressed, this pushbutton causes the printer to begin **printing** the user program in the selected **formats**.

STOP When depressed, this pushbutton causes the **printing** operation to stop.

80/132 Column Selection Switch

On the right side-panel is a **2-position** toggle switch used for selection of either 80 column printing format (compressed print) or 132 column printing format (normal print). The 80 column compressed print format is typically used with printers designed for use with personal computers. The selected printer column format corresponding with the switch position is printed on the right edge of the front panel, either 80 (towards the top of the unit) or 132 (towards the bottom of the unit). If desired, the 80 column compressed print format can be selected for use with a 132 column printer. The unused space to the right, beyond the 80th column, could be used for adding comments.

External Power Supply Connector

A connector located on the lower right side of the unit provides the connections to an external power supply. A mating **3-pin** connector with attached wires which are **3** feet (1m) in length, is provided with the Printer Interface Unit for connection to the external supply. The color code for the external power supply cable and specifications for the power supply are as follows:

White	+5 V dc, +5% (rated at 300 mA minimum)
Black	Power supply logic ground
Green	Common system ground

Power Supply Select Switch

This is a two-position switch located on the **bottom** of the unit, **directly** above **the 26-pin** connector. This switch is used for selection of either internal or external dc power for the Printer Interface **Unit**. The top switch position is labeled **EXT** (External) and the bottom position is labeled INT (Internal). If the Printer Interface Unit is to be powered by an external **+5 V** dc power **supply**, the Power Supply Select switch must be set to EXT.

Sequence of Operation

As a convenience to the user, instructions for using the Printer Interface Unit are printed on the **front** panel of the unit. The sequence of operation is described below. If a Series One Plus program is to be printed and a password is in effect, the password must be changed to 0000 before mounting the Printer Interface Unit.

Power-up Sequence

The following power-up sequence should be followed after the Printer Interface Unit has been properly configured.

1. Power to be supplied by the internal PC supply or an external power supply.
2. Place **EXT/INT** switch in the INT or **EXT** position as required.
3. Turn off power to the PC.
4. Mount Printer Interface Unit onto the PC.
5. Attach Printer Interface cable **from** connector on front panel of unit to printer.
6. Turn on power to the PC.
7. Turn on power to the external power supply, if used.

User Program Transfer From PC To Printer Interface Unit

Immediately after the power-up sequence has been completed, the user program stored in the PC's user memory will automatically begin transferring to a buffer memory in the Printer Interface Unit. This program transfer will take about 1.5 minutes. When the program has been successfully transferred, the FORM and PROD LED indicators will turn on green. If the program transfer is not successful, the LED indicators will either flicker on and off red or neither LED will illuminate. If after 2 minutes, neither LED turns on, repeat the power-up procedure **from** the beginning of the sequence.

Selection of Printout Format and Type of PC

Select the printout format, either ladder diagram or Boolean, and the PC model, either Series One Junior or Series One/Series One Plus by depressing the FORM and PROD switches as shown in the following table.

Table 4-5. Format and PC Selection

FORM		PROD	
PRINTOUT TYPE	LED ON	PC	LED ON
Ladder	Green	series one/be Plus	Green
Ladder	Green	Series One Junior	Red
Boolean	Red	series one/one Plus	Green
Boolean	Red	Series One Junior	Red

Start Printer Operation

Depress PRNT pushbutton. The ladder diagram or Boolean program listing will begin to print and continue printing until the complete program has been listed or has been stopped by the operator.

If at any time, the program listing is to be stopped, depress the STOP switch. When this is done during a ladder diagram printout, the printout will stop. When the STOP switch is depressed during a Boolean

GEK-90842

listing printout, the **Boolean** listing printout will stop, the printer will formfeed, and the complete OUTPUTS USED TABLE will be **printed**.

Printing Of Error Messages During Ladder Diagram Listing

If any errors in the **printing** process are detected by the Printer Interface Unit during printing of a ladder diagram listing, an error message will be printed and the printing may stop, depending on the type of error. Table 4-6 lists the error messages and their definitions.

Table 4-6. Ladder Diagram Listing Error Messages and Definitions

ERROR MESSAGE	DEFINITION
ROW OVER COLUMN OVER STACK ERROR (SR) STACK ERROR (CNT) STACK OVER STACK OVER (MCS) MC ERROR PROGRAM ERROR	One rung of logic exceeds 16 lines. More than 13 circuit elements in line Clock or Reset line not proved in Shift Register logic. Reset line not programmed in Counter logic. Pushdown stack using AND STR and OR STR functions exceeds 8 levels. Levels of MCS control exceed 8. MCR functions exceed MCS functions . Any error not listed in this table.

NOTE

When the **ROW OVER** or **COLUMN OVER** error messages are printed, the printout of the ladder diagram will continue. **When any** other error messages are printed, a **PRINT STOP** message will be printed, paper will **feed** and printing will stop.

Printing Of Error Messages During Boolean Listing

If any errors in the printing process are detected by the Printer Interface Unit during printing of a Boolean program listing, an error message will be printed and the printing may stop, depending on the type of error. Table 4-7 is the Boolean listing **error** messages and their definitions.

Table 4-7. Boolean Listing Error Messages and Definitions

ERROR MESSAGE		DEFINITION
INSTRUCTION	OPERAND	
ERROR	???	Not a valid instruction Incorrect operand

Cross Reference Printout

When the ladder diagram or Boolean printout of the user program has been **completed**, the printer will **formfeed**, then begin to print a cross reference printout of all outputs. The heading of this printout is, **OUTPUTS USED TABLE**. The **outputs referenced** in the user program (real world **outputs**, internal relays, **shift** registers and timers/counters) will have an annotation **mark** to the right of the reference number.

The outputs used table will continue printing until **all** output references have been printed. This printout cannot be stopped, as can the ladder diagram and Boolean listing printouts.

Expanded Print Format

When a more complex ladder diagram, using MCS and MCR functions, is to be printed out, an **expanded** print format is used. The starting point of each MCS function is denoted by a letter, the first is A, then B, etc. The letter is carried through to the end of each page and the beginning of the next page, providing a ready reference to the continuation of the ladder logic within the bounds of each **MCS/MCR** control. As multiple MCS functions and the logic under their control are printed, each succeeding group of logic is shifted to the right. When a group of logic under **MCS/MCR** control is ended by an MCR function, **(MCR)** is printed in the last column to the right and the letter corresponding to that **MCS/MCR** logic to its right.

Printout Annotation Explanation

Several items appearing on the printouts in figures 4-6 and 4-7 **are** explained for clarification. The ladder diagram printout in figure 4-6 has a circled number (1-5) next to each annotation, which corresponds to the number preceding the explanation of each annotation. The circled number 6 appears before an annotation on the Boolean printout in **figure** 4-7. The circled numbers (1-6) are for discussion purposes only and do not normally appear on a printout.

1. The type of printout on each page appears on this line, either **LADDER DIAGRAM PRINTOUT**, **BOOLEAN PRINTOUT**, or **CROSS REFERENCE PRINTOUT**.
2. This annotation, **V X.X**, is the version of the system operating software contained in PROM memory in the Printer Interface Unit.
3. The model of PC selected by the user as the program listing source will be on this line. The annotation will be either **SERIES ONE JR/SR-10** for a Series One Junior PC or Series One, One **Plus/SR-20**, **SR-21** for a Series One or Series One Plus PC.
4. The page number of the ladder diagram printout or Boolean printout will appear here as a **4-digit** decimal number, starting with **PAGE 0001**.
5. Refers to ladder diagram printout only. This **4-digit** decimal number is the user program memory address at the start of each rung of logic. The **first** element in the rung is stored **at** that address. In the example in figure 4-6, the memory address of the start of the first rung is 0000. The first element in that rung is a normally open contact referenced as **001** (reference number is printed directly above the contact). The memory address at the start of the second rung is 0013, the first element in this rung is a normally open contact referenced as 040.
6. Refers to Boolean printout only (figure 4-7). The **#** sign immediately following a numerical value in the Boolean printout listing, **indicates that the** value is a reference assigned to an element at the end of a rung.
7. A symbol preceding a numerical value in a Boolean printout, indicates that the value is a constant.

GEK-90842

Sample Printout

A sample of each of the previously described printouts is shown in the following group of figures. For this group of printouts, a program was entered into a Series One Plus PC.

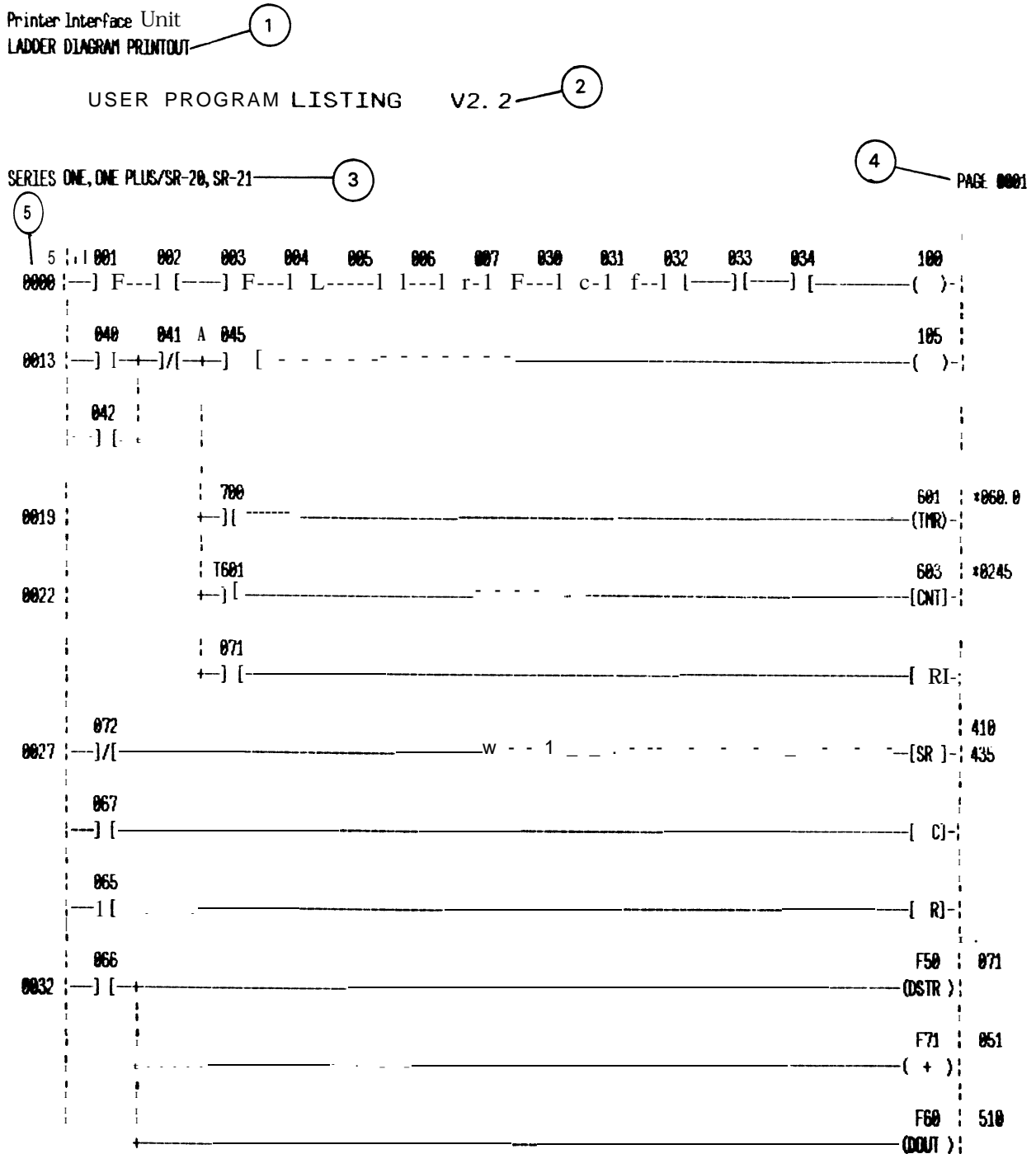

Figure 4-6. Sample Ladder Diagram Printout

Printer Interface hit
BOOLEAN PRINTOUT

USER PROGRAM LISTING

V2. 2

SERIES ONE, ONE PLUS/SR-20, SR-21

PAGE 0001

0000: STR	001	0050: -	0100: -	0150: -
0001: AND	002	0051: -	0101: -	0151: -
0002: AND	003	0052: -	0102: -	0152: -
0003: AND	004	0053: -	0103: -	0153: -
0004: AND	005	0054: -	0104: -	0154: -
0005: AND	006	0055: -	0105: -	0155: -
0006: AND	007	0056: -	0106: -	0156: -
0007: AND	030	0057: -	0107: -	0157: -
0008: AND	031	0058: -	0108: -	0158: -
0009: AND	032	0059: -	0109: -	0159: -
0010: AND	033	0060: -	0110: -	0160: -
0011: AND	034	0061: -	0111: -	0161: -
0012: OUT	1000	0062: -	0112: -	0162: -
0013: SIR	040	0063: -	0113: -	0163: -
0014: OR	042	0064: -	0114: -	0164: -
0015: AND NOT	041	0065: -	emr -	0165: -
0016: MCS		0066: -	0116: -	0166: -
0017: STR	045	0067: -	0117: -	0167: -
0018: OUT	1050	0068: -	0118: -	0168: -
0019: STR	700	0069: -	0119: -	0169: -
0020: THR	, 6010	0070: -	0120: -	0170: -
0021:	*060 0	0071: -	0121: -	0171: -
0022: SIR THR	601	0072: -	0122: -	0172: -
0023: STR	071	0073: -	0123: -	0173: -
0024: CNT	6030	0074: -	0124: -	0174: -
0025:	* 0245	0075: -	0125: -	0175: -
0026: MCR		0076: -	0126: -	0176: -
0027: STR NOT	\$72	0077: -	0127: -	0177: -
0028: STR	067	0078: -	0128: -	0178: -
0029: STR	065	0079: -	0129: -	0179: -
0030: SR	4100	0080: -	0130: -	0180: -
0031:	4350	0081: -	0131: -	0181: -
0032: STR	066	0082: -	0132: -	0182: -
0033: DSTR	(F50)	0083: -	0133: -	0183: -
0034:	071	0084: -	0134: -	0184: -
0035: +	(071)	0085: -	0135: -	0185: -
0036:	051	0086: -	0136: -	0186: -
0037: DOUT	(F00)	0087: -	0137: -	0187: -
0038:	5100	0088: -	0138: -	0188: -
0039: -		0089: -	0139: -	0189: -
0040: -		0090: -	0140: -	0190: -
0041: -		0091: -	0141: -	0191: -
0042: -		0092: -	0142: -	0192: -
0043: -		0093: -	0143: -	0193: -
0044: -		0094: -	0144: -	0194: -
0045: -		0095: -	0145: -	0195: -
0046: -		0096: -	0146: -	0196: -
0047: -		0097: -	0147: -	0197: -
0048: -		0098: -	0148: -	0198: -
0049: -		0099: -	0149: -	0199: -

Figure 4-7. Sample Boolean Printout

GEK-90842

PROM Writer Unit

The PROM Writer unit (catalog number **IC610PER154**, version B replaces version A and can be used with Series One Plus as well as Series One and Series One Junior) is a compact, easy to use device that connects directly to and mounts on a Series One or Series One Plus PC. When mounted on a PC, the PROM Writer unit is used to write the contents of user memory to a **2732A-2** PROM (Series One), or a **27256-25** for a Series One Plus, thereby providing a non-volatile means of user program storage. After being written to, the appropriate PROM can be installed in any Series One or Series One Plus PC as required. Programs stored in PROM memory will not be lost during no-power conditions.

An additional feature of PROM memory is that **different** programs can be stored on individual PROMS for use as required by various applications. Another function of the PROM Writer unit is to transfer the user memory contained in a PROM to the CMOS memory in a Series One or Series One Plus.

On a Series One or Series One Plus PC, the PROM Writer unit physically mounts on the right of the front panel, in the same manner as the programmer. A connector on the lower left rear of the PROM Writer unit attaches to the connector on the **front** panel of the Series One or Series One Plus PC. The source of power for the PROM Writer unit is switch selectable and can be **from** the internal supply of the PC or **from** an external source of 5 V dc. Figure 4-10 is an illustration of the PROM Writer showing the location of its features, which are described in the text following the illustration.

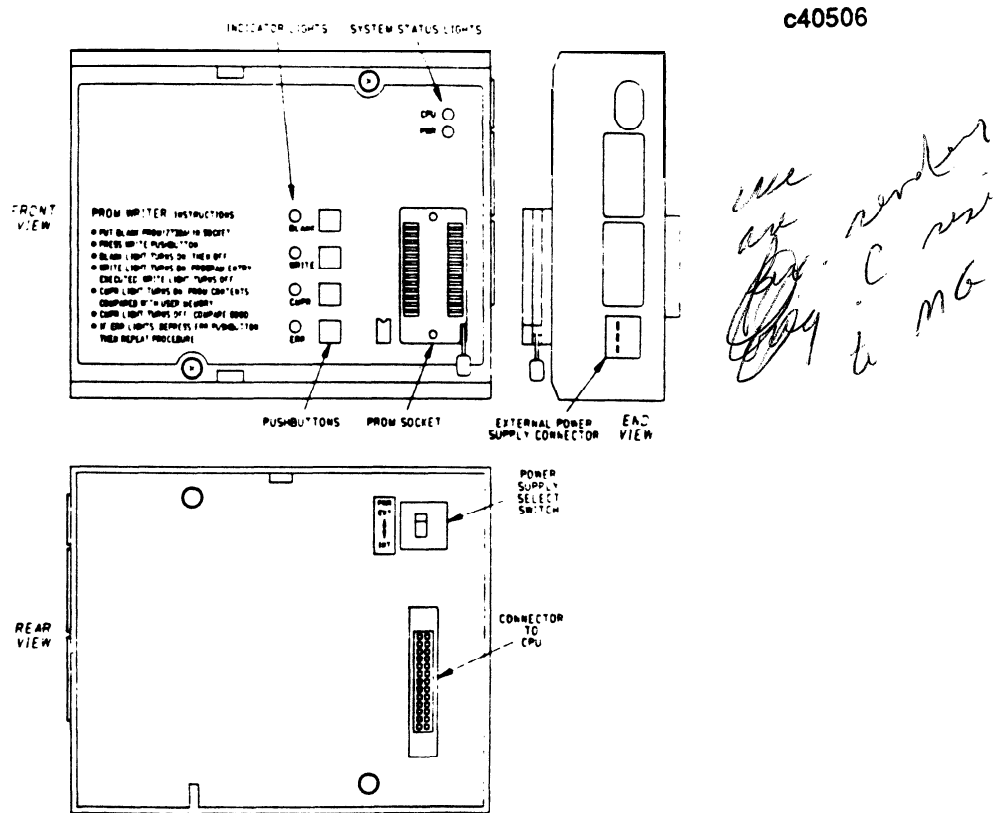

Figure 4-10. PROM Writer Unit Features

Front Panel Features

The front panel has two **LEDs** in the upper right corner which are visual indicators of system status. The purpose of each indicator is described below.

PWR	The green PWR LED monitors the status of dc power being supplied to the PROM Writer unit.
ON	If power is being supplied by the CPU rack, this indicates that +5 V dc is being produced by the supply. If the PROM Writer unit is being powered from an external source, the +5 V dc being supplied is within the specified tolerance.
OFF	5 V dc not being supplied or not in tolerance.
CPU	The red CPU LED monitors the operating status of the CPU module. Identical to the CPU LED on the Series One or Series One Plus CPU module.
ON	CPU failure has been detected.
OFF	CPU operation is normal.

The socket on the lower right of the panel is used to contain the PROM being written to. The socket is a zero insertion force socket. To insert a PROM into the socket, push the locking handle up, insert the PROM, then lock the PROM in place by moving the handle down to the horizontal position. The PROM should be placed in the socket with the notch towards the end of the socket closest to the PWR LED as indicated by the figure on the panel next to the socket. Even though the spacing of the slots in the socket allows easy insertion of a PROM, care should be taken to ensure that leads on the PROM are not damaged.

Immediately to the left of the socket are 4 pushbuttons and their associated LED indicators. These pushbuttons are used to initiate operation of the PROM Writer unit and the **LEDs** are indicators for each **part** of the operation.

BLANK	When depressed , initiates checking of the PROM inserted in the socket for verification that the PROM does not have any information written into it. To initiate a blank check, the pushbutton is depressed . The light will turn on, then off, indicating a successful blank check. If the light remains on, and the ERR light turns on, the PROM needs to be erased . The BLANK light will also turn on , then off during the normal operation of writing to a PROM as indicated by the instructions printed on the lower left of the unit .
WRITE	When depressed, the WRITE pushbutton initiates the sequence of events that causes the user program in the Series One or Series One Plus CMOS memory to be written to the PROM. When the WRITE pushbutton is depressed , the BLANK light will turn on, then off. Next, the WRITE light turns on , program entry is executed, then the WRITE light turns off. A blank check and verify are performed automatically when the WRITE pushbutton is depressed .
CMPR	During the sequence for writing to a PROM, this light will turn on while the contents of the PROM are being compared to the contents of user memory in RAM. The CMPR light turns off when the compare is completed and is good . If the compare is not good, the CMPR light will remain on and the ERR light will turn on . In addition, the contents of a PROM inserted in the PROM Writer unit socket can be compared to the contents of user memory, whenever the CMPR pushbutton is depressed.
ERR	This light is a visual indication that the PROM writing operation has not been successful . If the light turns on during any portion of the operation , an error has occurred . If this does happen, depress the ERR pushbutton and repeat the procedure .

As a convenience to the user, the PROM Writer unit instructions for writing the contents of user memory to a PROM **are** printed on the lower **left** of the **unit**.

GEK-90842

Sequence of Operation

The sequence of operation for writing the contents of user RAM memory to PROM memory is as follows:

WRITE OPERATION SEQUENCE	INDICATION
Depress WRITE pushbutton	WRITE light turn on
Blank check performed	WRITE light turns off BLANK light turns on
Write to PROM	BLANK light turns off WRITE light turns on
Verify contents of PROM with contents of RAM memory	WRITE light turns off CMPR light turns on
Write sequence successful	CMPR light turns off

The sequence of operation for transferring the contents of PROM memory to CMOS memory is as follows (the CMOS memory should be cleared first):

PROM TO RAM OPERATION SEQUENCE	INDICATION
Depress WRITE and CMPR pushbutton at the same time. Contents of PROM will be transferred to RAM memory in the PC.	WRITE light and CMPR light will turn on.
Contents of PROM and RAM memory are compared.	WRITE light turns off.
Compare good. Sequence of operation complete.	CMPR light turns off *

*If an error is detected during the compare operation, the CMPR light will remain on and the ERR light will turn on.. The error can be cleared by depressing the ERR pushbutton. **When** this is done, the ERR and CMPR lights will turn off. If an **error** is **indicated**, repeat the operation.

External Power Supply Connector

A connector located on the right side of the PROM Writer **unit** provides the connections to an external power supply. A mating **3-pin** connector with attached wires 3 feet (1m) in length, is provided with the PROM Writer unit for connection to the external supply. The color code for the external power supply cable and specifications for the power supply are as follows:

White	+5 V dc, +5% (rated at 0.5 amps)
Black	Power supply logic ground
Green	common system ground

Power Supply Select Switch

This is a two-position switch located on the bottom of the PROM Writer unit, directly above the **26-pin** connector. The switch is used for selection of either internal or external dc power for the PROM Writer unit. The top switch position is labeled EXT (External) and the bottom position is labeled **INT** (Internal). When used with a Series One or Series One Plus PC mounted in a high-capacity rack, power can be supplied internally and the Power Supply Select Switch **is** set to INT.

If erratic **operation** is observed when attempting a data transfer using the PROM Writer, it is recommended **that** an external source of **5 V** dc be used.

Timer/Counter Setpoint Unit

The Timer/Counter **Setpoint** Unit (IC609TCU100) provides an alternative method for entering a timer or counter preset value in a Series One Plus program. This unit can also be used with a Series One Junior. A Timer/Counter **Setpoint** Unit mounts on the Series One Plus rack that contains the CPU and plugs into the same connector as does the hand-held programmer. The Timer/Counter **Setpoint** Unit can also be connected remotely by using the 5 foot (1 .5m) remote programmer cable, IC610CBL102. With the unit mounted on the PC, the hand-held programmer can then be mounted on top of the Timer/Counter **Setpoint** Unit, thereby providing a convenient way to monitor the operation of timers or counters. The physical size of the unit is the same as the Data Communications Unit, Printer Interface Unit and the PROM Writer Unit.

a41 673

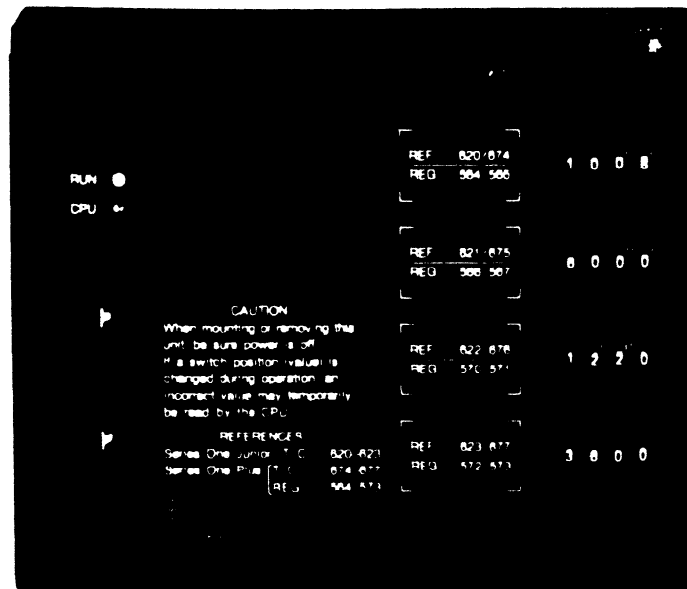

Figure 4-11. Timer/Counter **Setpoint** Unit

There are four **4-digit thumbwheel** switches on the unit, which provides a convenient way to enter a **4-digit BCD** value into each of 4 specific internal locations in the Series One Plus PC for use as Timer/Counter preset values. These values are simultaneously entered into data registers (two **8-bit** registers for each BCD digit) for use as preset values or for other data operations. When the BCD preset values have been entered into the PC, they are retained in the PC's memory as **presets**, even though power is removed **from** the PC and the unit is removed.

GEK-90842

Timer/Counter Setpoint Unit Specifications

The following table contains general specifications for the Timer/Counter **Setpoint** Unit.

Table 4-8. Timer/Counter Setpoint Specifications

Number of Circuits	4 (4 BCD digits per circuit)
Timer/Counter References	674, 675, 676, 677
Register References	564, 565 (T/C 674), 566, 567 (T/C 675) 570, 571 (T/C 676), 572, 573 (T/C 677)
Preset values	Timer: 0.1 to 999.9 seconds .01 to 99.99 seconds (Series One Plus 3.7 only)
Ambient Temperature	Counter: 1 to 9999 events
Storage Temperature	0° to 50° (32° to 122°F)
Humidity (non-condensing)	-20° to 85°C (-4° to 185°F)
Internal Power Consumption	5 V dc, 40 mA (maximum)
Units of Load	9 V dc, 5 mA (maximum)
Environment Considerations	4 units @ 5 V dc 1 unit @ 9 V dc No corrosive gases

Remote Mounting of Timer/Counter Setpoint Unit

A Unit Mounting Bracket, **IC610ACC190**, is available which allows mounting of the Timer/Counter **Setpoint** Unit on the outside of a panel or console. The Unit Mounting Bracket consists of a mounting bracket, connector clamp and a cable clamp. The Timer/Counter **Setpoint** Unit mounts on the bracket, secured by two captive screws on the unit. The unit connects to a Series One Plus PC through the round 5 foot (1.5m) remote programmer cable, **IC610CBL102**.

References for the Timer/Counter Setpoint Unit

The Timer/Counter **references** for the memory locations into which the BCD values are entered in the Series One Plus are **674, 675, 676** and **677**. Each of the references refer directly to a memory location in the CPU that accepts one **4-digit** BCD value as it is entered with each **4-position** thumbwheel switch. Each thumbwheel position represents one BCD digit, with the least significant digit being the position to the right.

Each of the register references refers to an **8-bit** data register. Two consecutive registers are **required** for each **4-digit** BCD number.

Since all four BCD values are read into the PC each scan, discretion must be exercised when changing any values when the PC is running, since undesired intermediate values could be read by the CPU and used during one or several scans. It is recommended that the following CAUTION be followed.

CAUTION

When mounting or removing the Timer/Counter Setpoint Unit, be sure that power is turned off. If a switch position (value) is changed during operation, an incorrect value may temporarily be read into the CPU.

Example of Using Thumbwheel Inputs

The following example of a ladder **diagram rung** shows how the Timer/Counter **Setpoint** Unit is used to enter a preset value into a Timer or counter, or to enter data into data **registers**.

a421 86

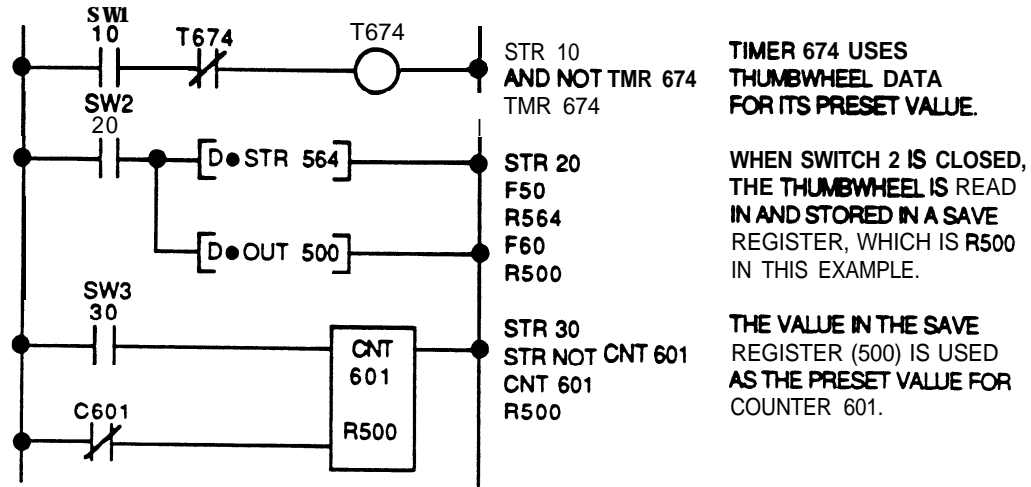

SECTION 1 Introduction to Programming

General Information

The Series **One™** and **Series One™ Plus** are easy to use small PCs with many advanced features. One of the advantages of these PCs is the ability to be programmed or tailored specifically to the needs of an application. Furthermore, if requirements change, the PC can be reprogrammed to fit the new application. This chapter provides the information a user needs to develop or modify the logic within the Series One or Series One Plus. It will discuss the basics of CPU operation necessary to develop a proper logic program, the theory behind each function, examples of how that function could be used, and step-by-step **entry** of sample programs.

Planning a PC System

When planning a **PC** system, the first step should be to **define** the system by writing a description of the **functional** requirements for that system. A description would usually consist of block diagrams and written descriptions of the various parts of the system. Input **devices** should be defined along with the process or machines to be **controlled**. The next step would be to develop the program required to control the system.

On a sheet of paper, **layout each rung of your ladder diagram and assign references to** inputs and outputs. The program can also be **written in mnemonic form (Boolean), which is how** it will be keyed into the Series One or Series One Plus when using the hand-held programmer. As an option, programs can be entered in ladder diagram Format using the Portable Programmer. This applies to both the Series One and Series One Plus. You can also enter programs with the **Workmaster®** industrial computer using **Logicmaster™1** application software. For **information** on using the **Workmaster** industrial computer for **programming**, refer to the **Logicmaster 1 Programming** manual, **GEK-96632** for Series One. For Series One Model E, Series One Plus, and Series One Plus **3.7K**, refer to GFK-0075 which is the **Logicmaster 1 Family Programming Manual**.

How to Use This Chapter

This chapter is divided into 3 sections. Section 1 is a description of the requirements for programming. Included, are lists of all of the programming functions and a table of programming references assigned to each slot for 8 point modules. The purpose and types of references are explained, including “real world” use and internal use. A basic explanation of the scanning operation of the Series One and Series One Plus PCs is given. The scanning process is the basis for operation of all PCs and the user should have a good working knowledge of this operation.

The next 2 sections are devoted to programming. Section 2 describes and gives examples of the basic ladder diagram functions. Section 3 provides the user with a description of the data operation functions for use with a Series One Plus PC. The data operations greatly extend the number and complexity of applications possible with the Series One family.

Table 5.1 lists the basic ladder diagram functions for the Series One and Series One Plus. A more detailed explanation of each instruction can be found later in this chapter. Execution times in Table 5.1 are for Series One Model E, Series One Plus, and Plus 3.7K only. Execution times for Series One are listed in Table 5.2. Note that in the table, I/O = I/O points, IR = Internal Relay, SR = Shift Register.

Table 5-1. Series One Model E/One Plus Basic Ladder Diagram Instructions

Instruction	Definition	Memory Words	Execution Time (microseconds) For Series One Plus	
			Inactive	Active
STR	START. Start rung with a N.O. (Normally Open) contact.	1	6.6 50.9	6.6 I/O,IR,SR 50.9 Sequencer
STR TMR	START TIMER. Start rung with a N.O. contact referencing a timer.	1	10.3	10.3
STR CNT	START COUNTER. Start rung with N.O. contact referencing a counter.	1	10.3	10.3
STR NOT	START NOT. Start rung with a N.C. (Normally Closed) contact.	1	9.1 61.5	9.1 I/O,IR,SR 61.5 Sequencer
STR NOT TMR	START NOT TIMER. Start rung with a N.C. timer contact.	1	12.8	12.8
STR NOT CNT	START NOT COUNTER. Start rung with a N.C. counter contact.	1	12.8	12.8
AND	Add a N.O. contact in series with the previous contact.	1	5.3 6.2	5.3 I/O,IR,SR 59.1 Sequencer
AND TMR	AND TIMER. Add a N.O. timer contact in series with the previous contact.	1	5.3	5.3
AND CNT	AND COUNTER. Add a N.O. counter contact in series with the previous contact.	1	5.3	5.3
AND NOT	Add a N.C. contact in series with the previous contact.	1	8.4	8.4 I/O,IR,SR 60.3 Sequencer
AND NOT TMR	AND NOT TIMER. Add a N.C. timer contact in series with the previous contact.	1	8.4	8.4
AND NOT CNT	AND NOT COUNTER. Add a N.C. counter contact in series with the previous contact.	1	8.4	8.4
OR	Add a N.O. contact in parallel with the previous contact.	1	6.6 6.2	6.6 I/O,IR,SR 60.3 Sequencer
OR TMR	OR TIMER. Add a N.O. timer contact in parallel with the previous contact.	1	6.6	6.6
OR CNT	OR COUNTER. Add a N.O. counter contact in parallel with the previous contact.	1	6.6	6.6
OR NOT	Add a N.C. contact in parallel with the previous contact.	1	9.1 6.2	9.1 I/O,IR,SR 62.5 Sequencer
OR NOT TMR	OR NOT TIMER. Add a N.C. timer contact in parallel with the previous.	1	9.1	9.1

GEK-90842

Table 5-1. Series One Model E/One Plus Basic Ladder Diagram Instructions - Continued

Instruction	Definition	Memory Words	Execution Time (microseconds) For Series One Plus	
			Inactive	Active
OR NOT CNT	OR NOT COUNTER. Add a N.C. counter contact in parallel with the previous contact .	1	9.1	9.1
AND STR	AND STORE. Connects a logic group in series with the logic group preceding it.	1	3.8	
OR STR	OR STORE. Connects a logic group in parallel with the logic group preceding it.	1	3.8	
MCS	MASTER CONTROL START. Begin control of a block of logic with a master control relay.	1	5.0	
MCR	MASTER CONTROL RESET. Ends control of a block of logic with a master control relay.	1	3.0	
OUT	Defines a coil for a rung of logic, either an external output or an internal coil .	1	7.5	
SET	Defines a coil as being latched , the coil will remain on until turned off by RST.	1	17.5	
SET OUT	IF ON, the coil will remain ON even under control of the Output Disabler Coil (376).	1	10.0	
RST	RESET. Causes a coil that had been latched (SET) to be unlatched (Reset).	1	9.3	
SET OUT RST	SET OUT RESET. Defines a coil as being a one-shot (ON for one scan).(One Plus Only)	1	19.3	
TMR	TIMER . Programs a Timer operation. Times up from zero to a preset value. Elapsed time stored in an accumulate register. Preset time range is 0.1 seconds to 999.9 seconds.	2	27.1	100.0 I/O,IR,SR 458.8 Register
CNT	COUNTER. Programs an up counter. Counts up from zero to a preset value which can be 1 to 9999. The current count is stored in an accumulate register. Counters are retentive. Requires 2 rungs of logic; first rung enables the counter, the second rung resets the counter.	2	27.1	106.8 I/O,IR,SR 465.6 Register
SR	SHIFT REGISTER . Programs a shift register which can be 128 steps in length or a number of shift registers of varying lengths (128 bits total). Retentive . Requires 3 rings of logic; (1) data , (2) clock , (3) reset . can be programmed to shift forward or backward .	2	53.1	64.1 +16.6 For each bit shifted

Note: I/O = I/O Points, IR = Internal Relay, SR = Shift Register

Table 5.2 is a list of execution times for the Series One functions. Execution times are given in microseconds.

Table 5-2. Series One Execution Times

Instruction	I/O Point	Int Relay	Shift Register	Timer	Sequencer	
					Counter	Inactive
AND	33.9		32.7	37.5	36.0	84.0
AND NOT	36.5		35.1	39.9	40.8	88.8
OR	36.3		34.5	43.5	36	84.0
OR NOT	38.7		36.9	45.6	40.8	88.8
STR	40.8		39.6	48.0	89.4	89.4
STR NOT	42.0		43.2	50.4	97.2	97.2
SET	38.1		42.6			
RST	38.1		42.6			

Instruction	Inactive	Active
MCS	35.2	35.2
MCR	37.8	37.8
SET OUT	49.8	49.8
OUT	43.8	43.8
TMR	69.6	115.8
CNT	80.4	103.5
SR	55.2	66.9 + 12.9/N (1)
ANDSTR	34.2	34.2
OR STR	37.8	37.8

(1) N = number of bits shifted.

Table 5.3 is a list and description of the data operations that can be programmed, with a Series One Plus, in addition to the basic ladder diagram functions listed in Table 5.1. A more detailed explanation of each instruction is provided later in this chapter.

Table 5-3. Series One Plus Data Operation Instructions

Instruction	Definition	Memory Words	Execution Time (microseconds)	
			Inactive	Active
D•STR (F50)	DATA STORE. Loads accumulator with a binary or BCD value which can be a 4 digit constant or the contents of a specified 2 byte reference.	2	6.3	321.9 I/O,IR,SR 80.7 Register 14.3 Constant
D•STR1 (F51)	DATA STORE 1. Loads the lower byte (least significant) of the accumulator with the contents of a specified 1 byte reference.	2	6.3	140.9 I/O,IR,SR 63.8 Register
D•STR2 (F52)	DATA STORE 2. Loads the lower 4 bits of the accumulator with the upper 4 bits of a specified 1 byte reference.	2	6.3	172.2 I/O,IR,SR 95.0 Register
D•STR3 (F53)	DATA STORE 3. Loads the lower 4 bits of the accumulator with the lower 4 bits of a specified 1 byte reference.	2	6.3	173.8 I/O,IR,SR 96.6 Register

GEK-90842

Table 5-3. Series One Plus Data Operation Instructions - Continued

Instruction	Definition	Memory Words	Execution Time (microseconds)	
			Inactive	Active
D•STR5 (F55)	DATA STORE 5. Loads accumulator with a binary or BCD value from the 2 byte contents of a 16 circuit (high density) Input Module.	2	63	325.0 16 Point Input Module
D•OUT (F60)	DATA OUT. The contents of the accumulator (2 bytes) are written to a specified 2 byte reference (Output, Internal Relay, Shift Register Coils, Data Register or T/C Accumulate Register).	2	63	329.4 I/O,IR,SR 52.6 Register
D•OUT1 (F61)	DATA OUT 1. The contents of the lower byte of the accumulator are written to a specified 1 byte reference (Output, Internal Relay, Shift Register or Data Register).	2	63	160.1 I/O,IR,SR 39.1 Register
D•OUT2 (F62)	DATA OUT 2. The contents of the lower 4 bits of the accumulator are written to the upper 4 bits of a specified 1 byte reference (Output, Internal Relay, Shift Register or Data Register).	2	63	116.0 I/O,IR,SR 39.8 Register
D•OUT3 (F63)	DATA OUT 3. The contents of the lower 4 bits of the accumulator are written to the lower 4 bits of a specified 1 byte reference (Output, Internal Relay, Shift Register or Data Register).	2	63	108.1 I/O, IR, SR 55.0 Register
D•OUT5 (F65)	DATA OUT 5. The contents of the accumulator (2 bytes) are written to a specified 2 byte reference. Must be a 16 circuit (high density) Output module.	2	63	365.3 16 Point Output Module
= < (F70)	COMPARE. The contents of the accumulator are compared to the contents of a specified 2 byte reference (I, IR, SR, or DR) or a 4 digit BCD constant. Internal coils turn on to reflect the result of the comparison. Acc > DataOn 772 Acc = DataOn 777 Acc < Data011 774	2	63	354.0 I/O,IR,SR 112.8 Register 57.0 constant
+ (F71)	ADDITION (BCD). The contents of the accumulator are added to a 4 digit BCD constant or the contents of a specified 2 byte reference which must be a valid BCD number (Input, Internal Relay, Shift Register or Data Registers).	2	63	698.0 I/O,IR,SR 456.8 Register 262.0 Constant
- (F72)	SUBTRACTION (BCD). The contents of a specified 2 byte reference (Input, Internal Relays, Shift Register, or Data Registers) or a 4 digit BCD constant are subtracted from the contents of the accumulator.	2	63	557.0 I/O,IR,SR 3 15.8 Register 275.0 Constant
X (F73)	MULTIPLICATION (BCD). The contents of the accumulator are multiplied by the contents of a specified 2 byte reference (Input, Internal Relays, Shift Register, or Data Registers) or a 4 digit BCD constant. The lower 4 digits of the result remain in the accumulator, the upper 4 digits are stored in registers 576 and 577 which is the auxiliary accumulator.	2	63	497 to 2851 (I/O,IR,SR) 290 to 2644 (Register) 223 to 2576 (Constant)

Table 5-3. Series One Plus Data Operation Instructions - Continued

Instruction	Definition	Memory Words	Execution Time (microseconds)	
			Inactive	Active
÷ (F74)	DIVISION (BCD). The contents of the accumulator are divided by the contents of a specified 2 byte reference (I, IR, SR, or DR) or a 4 digit BCD constant. The first 4 digits of the answer are stored in the accumulator and the remainder is stored in the remainder is stored in the auxiliary accumulator (registers 576 and 577).	2	63	1218 to 2851 (I/O, IR, SR) 742 to 2645 (Register) 720 to 2577 (Constant)
D•AND (F75)	DATA AND (Logic product). The contents of the accumulator are logically AND-ed with each corresponding bit of a specified 2 byte reference (I, IR, SR, or DR) or a 4 digit BCD constant. The result is stored in the accumulator.	2	63	345.0 I/O,IR,SR 103.7 Register 55.6 Constant
D•OR (F76)	DATA OR (Logic Sum). The contents of the accumulator are logically OR-ed with each corresponding bit of a specified 2 byte reference (I, IR, SR, or DR) or a 4 digit BCD constant. The result is stored in the accumulator.	2	63	345.0 I/O,IR,SR 103.7 Register 55.6 Constant
SHIFT RIGHT (F80)	FUNCTION 80, SHIFT RIGHT N BITS. Contents of the accumulator are shifted to the right by the specified number of bits (1-15). Positions from which bits were shifted are filled with zeros.	2	63	216 + 13.4/N of bits shifted
SHIFT LEFT (F81)	FUNCTION 81, SHIFT LEFT N BITS. Contents of the accumulator are shifted to the left by the specified number of bits (1-15). Positions from which bits were shifted are filled with zeros.	2	63	220 + 13.4/N of bits shifted
DECODE (F82)	FUNCTION 82, DECODE. Decodes the lower 4 bits of the accumulator to a decimal number from 0 to 15 and places a 1 in the bit position in the accumulator which corresponds to that decimal number.	1	63	56.3
ENCODE (F83)	FUNCTION 83, ENCODE. Encodes a bit in the accumulator to a binary code representing the position number (0 - 15) and places the binary code in the lower four bits of the accumulator.	1	63	282.0
INV (F84)	INVERT. The 16 bits of the accumulator are inverted; i.e., 1 to 0 and 0 to 1. Example: 1101 1001 0110 0111 inverted to 0010 0110 1001 1000	1	63	30.3
BIN (F85)	BINARY. Converts a BCD value in the accumulator to a binary code.	1	63	412.2
BCD (F86)	BINARY CODED DECIMAL. Converts a binary code in the accumulator to a BCD value.	1	63	746.0
EXTERNAL FAULT DIAGNOSIS (F20)	FUNCTION 20, EXTERNAL FAULT DIAGNOSIS. Allows external &vices to be monitored for unwanted conditions. If a fault occurs a preassigned 4 digit BCD number is displayed on the programmer. Multiple fault conditions can be monitored.	1	63	355.3 I/O,IR,SR 114.0 Register 722 Constant

Programming Fundamentals

This section provides a guide for entering and using each of the instructions. The instructions are presented in groups that correspond to their functionality. Table 5.4 lists the instructions grouped in this manner.

Table 5-4. Series One/One Plus Instruction Groups

BASIC INSTRUCTIONS	
	STR, STR TMR, STRCNT, STR NOT, STR NOT TMR, STR NOT CNT AND, AND TMR, AND CNT, AND NOT, AND NOT TMR, ANDNOTCNT OR, ORTMR, ORCNT, ORNOT, ORNOTTMR, ORNOTCNT ANDSTR, ORSTR MCS, MCR, OUT, SET, SET OUT, RST, SET OUT RST (ONE PLUS ONLY) TMR, CNT, SR
DATA OPERATIONS	
SERIES ONE PLUS ONLY	
MOVE	D•STR (F50), D•STR1 (F51), D•STR2 (F52) D•STR3 (F53), D•STR5 (F55) D•OUT (F60), D•OUT1 (F61), D•OUT2 (F62) D•OUT3 (F63), D•OUT5 (F65)
ARITHMETIC	>=< (F70), + (F71), - (F72), x (F73), ÷ (F74)
LOGICAL	D•AND (F75), D•OR (F76), INV (F84)
CONVERT	BIN (F85), BCD (F86), Shift Right (F80) Shift Left, (F81) Decode (F82), Encode (F83)
SPECIAL	External Fault Diagnosis (F20)

Significance of References

Whenever programs are entered into any PC, they must be accompanied by reference numbers. These references help to tell the CPU which function is specified. For example, which pushbutton controls the starting of which motor? Which timer are you referring to? Reference numbers are a vital part of programming, and in the Series One and Series One Plus are octal based; that is, they start at 0 and go up to 7, then jump to 10; at 77 the next value is 100. They look like traditional decimal numbers, except the digits 8 and 9 do not exist. Table 5.5 **summarizes** the various reference values and their **significance**.

Table 5-5. Summary of References

Octal Values	References	Decimal Quantity
000-157	I/O points (Series One)	112 total
000-157	I/O points (Series One Plus)	168 total
700-767	(Series One Plus only)	
770-777	Special Function Coils (Series One Plus only)	8
160-337	Internal Coils (Non-retentive)	112
340-373	Retentive Coils (Internal)	28 (1)
374-377	Special Functions	4 (1)
400-577	Shift Registers	128 (1)
600-677 (4)	Timers and/or Counters	64 (2) (1)(2)
400-577	Data Registers, 16-bit (Series One Plus only)	64 (3), 124 Total if T/C references used as data registers

1. Retentive upon power failure.
2. Total maximum number of Timers and/or Counters.
3. Shift register and data register references are identical however, shift registers operate on bits, while data registers (located in a different area of memory) operate on bytes.
4. T/C references 600-673 can be used as data registers, if they are not referenced as timers or counters.

Significance of Input/Output References

I/O modules can be placed in any mix desired; however, once installed the exact reference used in programming is established by their physical placement. In other words, references are assigned to each location by the operating system in the CPU, and therefore **are fixed** for each location. As shown in the example in Figure 5.1, the modules are numbered **from** zero (adjacent to CPU) towards the **left** through all racks until the last module is reached at the left of the last rack. The exact reference is obtained by appending the circuit number (**0-7**), to the module number. Circuit numbers depend upon the terminal to which the field device is wired as discussed in Chapter 6. Table 5.6 summarizes available **I/O** references for 8 circuit modules for your convenience. This table can be reproduced locally to form a part of your system documentation. Notice that whether reference 005 is an input or an output depends upon which module is inserted into the **I/O** slot adjacent to the CPU. Refer to the Series One family compatibility guide in Appendix C for additional valid **I/O** references per physical location of modules.

GEK-90842

a40797

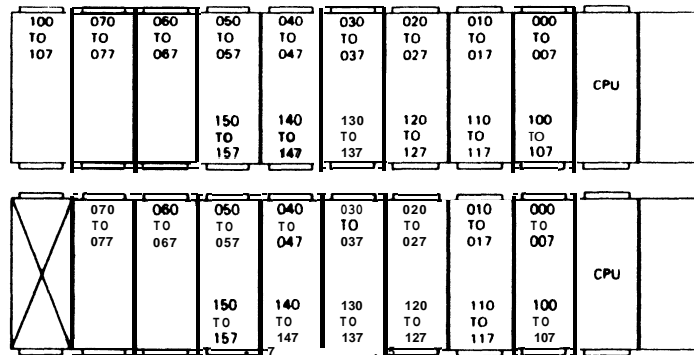

10 SLOT RACKS
EXAMPLE SERIES ONE PLUS I

pc-s1-83-0068

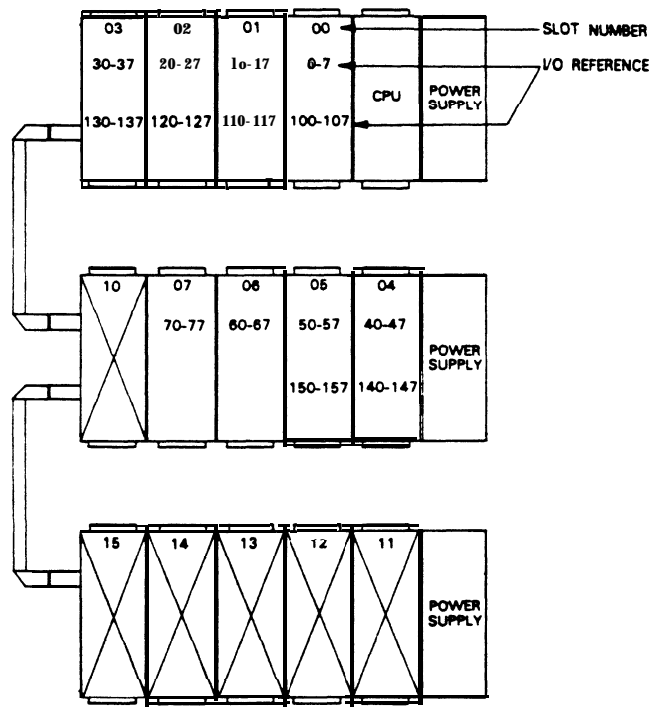

5-SLOT RACKS
(EXAMPLE-SERIES ONE)

Figure 5-1. I/O References Per Physical Placement for 5 and 10-Slot Racks

NOTE

The addressing of slot 10 in a **10-slot** rack is determined by configuration of the two bridge connectors on the rack backplane.

Table 5-6. Summary of I/O References for 8 Circuit Modules

Module No.	Circuit No.	Reference	In/Out	Device Name	Wire No.
00	0	000			
	1	001			
	2	002			
	3	003			
	4	004			
	5	005			
	6	006			
	7	007			
01	0	010			
	1	011			
	2	0i2			
	3	013			
	4	014			
	5	015			
	6	016			
	7	017			
02	0	020			
	1	021			
	2	022			
	3	023			
	4	024			
	5	025			
	6	026			
	7	027			
03	0	030			
	1	031			
	2	032			
	3	033			
	4	034			
	5	035			
	6	036			
	7	037			
04	0	040			
	1	041			
	2	042			
	3	043			
	4	044			
	5	045			
	6	046			
	7	047			
05	0	050			
	1	051			
	2	052			
	3	053			
	4	054			
	5	055			
	6	056			
	7	057			
06	0	060			
	1	061			
	2	062			
	3	063			
	4	064			
	5	065			
	6	066			
	7	067			

GEK-90842

Table 5-6. Summary of I/O References for 8 Circuit Modules - Continued

Module No.	Circuit No.	Reference	In/Out	Device Name	Wire No.
07	0	070			
	1	071			
	2	072			
	3	073			
	4	074			
	5	075			
	6	076			
	7	077			
10	0	100			
	1	101			
	2	102			
	3	103			
	4	104			
	5	105			
	6	106			
	7	107			
11	0	110			
	1	111			
	2	112			
	3	113			
	4	114			
	5	115			
	6	116			
	7	117			
12	0	120			
	1	121			
	2	122			
	3	123			
	4	124			
	5	125			
	6	126			
	7	127			
13	0	130			
	1	131			
	2	132			
	3	133			
	4	134			
	5	135			
	6	136			
14	0	140			
	1	141			
	2	142			
	3	143			
	4	144			
	5	145			
	6	146			
	7	147			
15	0	150			
	1	151			
	2	152			
	3	153			
	4	154			
	5	155			
	6	156			
	7	157			

Table 5-6. Summary of I/O References for 8 Circuit Modules - Continued

Module No.	Circuit No.	Reference	In/Out	Device Name	Wire No.
70	0	700			
	1	701			
	2	702			
	3	703			
	4	704			
	5	705			
	6	706			
	7	707			
71	0	710			
	1	711			
	2	712			
	3	713			
	4	714			
	5	715			
	6	716			
	7	717			
72	0	720			
	1	721			
	2	722			
	3	723			
	4	724			
	5	725			
	6	726			
	7	727			
73	0	730			
	1	731			
	2	732			
	3	733			
	4	734			
	5	735			
	6	736			
	7	737			
74	0	740			
	1	741			
	2	742			
	3	743			
	4	744			
	5	745			
	6	746			
	7	747			
75	0	750			
	1	751			
	2	752			
	3	753			
	4	754			
	5	755			
	6	756			
	7	757			
76	0	760			
	1	761			
	2	762			
	3	763			
	4	764			
	5	765			
	6	766			
	7	767			

Internal Coils

The internal coils are control relays that can be used to control logic in the Series One or Series One Plus user program. However, their status cannot be provided directly to the I/O section. Retentive relays are specialized internal coils that have their ON or OFF status retained during time periods that the PC is not operating such as during loss of AC power. They use dual operations (set and reset) similar to hard-wired latching relays. A switch (**S1**) on the CPU module must be set to the ON position in order for the internal coils, 340 to 377, to be retentive upon loss of power. If the switch is not set properly, these coils will function as non-retentive coils.

Use of the Special Function Coils

Internal coils 374 through 377 are special purpose coils, in that they always perform specific internal functions and also provide useful internal system status. Coil 374 is a **first** scan reset or power-up indicator. Coil 375 provides a convenient way to program a 0.1 second clock pulse. **Coil 376 can be used to inhibit all hardware outputs, that is, outputs that are connected to user devices (programmed with an OUT ~~XXX~~ instruction).** Finally, coil 377 is an indicator of the operating status of the back-up battery for the CMOS memory devices. This coil could be used as a contact to **turn** on an output connected to a light, bell, etc. as a visual warning of a low battery.

Shift Register References

A group of references (**400** to 577) are used by the shift register. A total of 128 stages are possible and they can be used as one large shift register or a group of smaller shift registers (for example, 3 @ 30 stages and 2 @ 19 stages) as long as the total number of stages does not exceed 128. Additional details on all these functions will be provided later in this chapter.

Timer and Counter References

Another group of **fixed** references (**600** to 677) are used with timers and counters. Any mix of timers or counters totaling 64 can be used in a Series One or Series One Plus PC. Counters provide an additional function, in that they can also control a sequencer with up to 1000 steps. Counters are retentive upon power failure. References 600 to 673 can be used as **16-bit** data registers if they are not used as T/C references. T/C references 674-677 are reserved for Thumbwheel Interfaces or Timer/Counter Set Point use only.

Data Registers

Data registers are available **only with** a Series One Plus PC. This is a group of sixty four **16-bit** registers which can be used for storage of numerical data. Data can be written to or read from the data registers for use by the data operation instructions. Additionally data stored in the **registers** can be used as Timer/Counter presets. The references to be assigned to these registers are 400 to 577. Note that these references are identical to the shift register references. However, shift registers operate on individual bits (**400, 401, 402**, etc.), while the data registers operate on bytes and are located in a totally **different area** of memory. A byte in the Series One Plus PC is a group of 8 consecutive bits and each register is 2 bytes in length. By using available T/C references, the total number of data registers references can be up **to 124**.

Flexibility in Using References

Although references are assigned to specific functions as shown in Table 5.5, there is some flexibility in their use. I/O references not used by the hardware I/O section (for example, no module inserted into that slot or circuit not wired up) can be used as internal coils. However, if expansion is planned for the future, sufficient references to support that expansion should be reserved and not used in the current programming. Retentive coils can also be used as internal coils if their retentive function is not **required**. However, typically the unique value of retentive relays does not justify their sacrifice for a few internal coils. The shift register references can be used as a source for additional retentive or internal coils if they are not used for shift registers or sequencers.

Operating Principles

Before discussing the details of programming and the use of references, some details on the internal operation of the CPU can be useful. The majority of Series One and Series One Plus applications can be solved and the programs developed without consideration of the internal structure of the CPU. However, some applications can be more efficiently solved if knowledge of the CPU operation is applied while the program is being developed. The basic operation of virtually all PCs is referred to as a scanning function. There are many hundreds of decisions to be performed in any program, and the CPU cannot do all of them simultaneously. Similar to any electronic processor, it performs its operations one at a time. However, the speed of performance internally, makes the external results appear to have all operations accomplished at once.

Scanning

The term scan is a method of describing how the CPU performs its assigned tasks (see Figure 5.2). It begins at the **first** function, such as a relay contact, entered into the beginning of memory (address 0000). It proceeds sequentially through all memory addresses performing all functions entered by the user (for example, relay contacts, timers, latching relays, counters, sequencers, shift registers, etc.) until it reaches either the end of memory (address 1723) or the end of the program as entered by the user.

During the scan the logic sets or resets coils, according to the instructions entered into the logic program by the user. The status of these coils is immediately available to the next logic function. At the end of the logic scan, the CPU gets input data **from** the input modules and provides new data to output modules.

Next, the programmer, if connected, is serviced by making logic changes and/or updating its display. After servicing the programmer, the CPU performs a check of its internal hardware and resets the watchdog timer. The watchdog timer is a hardware timer set at 180 **msec** (milliseconds) to ensure that **memory or internal** circuit faults do not cause the CPU to enter **an** endless loop because of hardware failure. If a scan is not completed at least once every 180 **msec** (typical maximum scan is 60 msec), **the** hardware will shut the CPU down turning outputs OFF. Finally, any forced I/O **will** be entered. With successful completion of the internal checks, the CPU goes back to the start of the scan and continues its scanning sequence with the logic function entered at address **0000**. This repetitive scanning operation is performed from the time power is applied to the CPU until it is removed.

Total scan time includes user logic solution time plus overhead. The overhead time includes monitoring functions, I/O updates and housekeeping tasks. The typical scan times listed in the specifications in Chapter 1 assume that only basic instructions have been programmed (AND, OR, STR, NOT, etc.), they do not include overhead. The **overhead** time is about the same (4 to 5 **mSec**) for Series One and Series One Plus. This time must be added to the logic solution time to obtain the total real scan time.

GEK-90842

In order to achieve the maximum scan time, the monitor function should be disabled for both Series One and Series One Plus programs, since the monitor function adds about 2 **mSec** of overhead time when it is active. Also the overhead of a Series One Plus is increased slightly when communicating through the DCM, since both the Series One Plus CPU and DCM have been designed to provide a much higher throughput than the Series One **CPU/DCM** combination. Additionally, timer and counter instructions in the Series One Plus are slower than in the Series One because of the ability to use registers for preset values.

The scanning operation is very basic to PC operation and should not be overlooked. It provides a very useful verification of the CPU's reliability. For details on troubleshooting, refer to Chapter 7. The scanning operation also provides a fixed and definable sequence of logic decisions. Functions are solved in the order programmed. The results of one function (for example, coil, timer, shift register, etc.) are immediately available internally to the next logic element. In larger complex logic programs, internal races can be eliminated. The user does not need to be concerned with the time delay relays required to **pull in** or activate nor their variations (for example, a 4 pole vs 8 pole relay).

pc-s1-83-0004

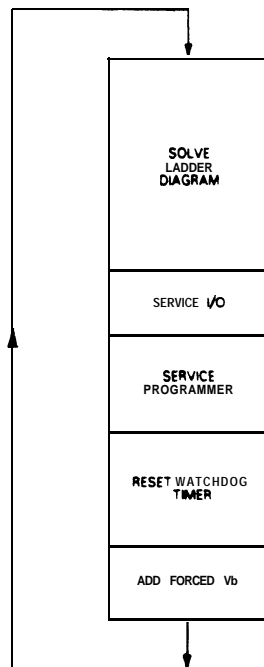

Figure 5-2. CPU Scanning Sequence

Programmer Functions

The basic programming language of the Series One and Series One Plus PCs is a simple relay ladder representation based upon standard Boolean functions (AND, OR, and NOT). Throughout the discussion of programming, examples will be used to illustrate the function described. The illustration of the Programmer (Figure 5.3) will be used as a reference for these examples and specific key sequences will

be provided so that the user can follow and demonstrate the example. A short-hand notation will also be provided that is recommended as a simple method to document your program. A complete discussion of the programmer is provided in Chapter 4. A brief overview of important keys is presented below to aid the user's understanding of the examples.

The keyboard has both upper and lower case functions similar to a typewriter. The numerical keys for most programming steps are accessed by first selecting the SHF (Shift) key to the upper right. Once depressed, the SHF LED is lit (display center right) and then the appropriate numerical digit(s) can be selected. The shift function is latched and will be released only by selection of the ENT (Enter) or CLR (Clear) key. The SHF key does not have to be held down. The display window in the upper left reflects either address or data information (not both) as the operation progresses. Typically, as keys are selected, their respective LEDs will light to display the function selected. Other important keys are as follows:

KEY	FUNCTION
AND	AND referenced status with previously entered logic (Series)
OR	OR referenced status with previously entered logic (Parallel)
STR	START new rung of a ladder diagram
NOT	NOT or invert (i.e. make normally closed) contact referenced
OUT	OUTPUT logic status to a coil, either output or internal
TMR	TIMER is selected as desired function
CNT	COUNTER is selected as desired function
SET	SET latching relay or shift register status
MCS	Master Control Start - begin control of master control relay
MCR	Master Control Reset - end control of master control relay
SR	Shift Register - establish range of shift register
RST	RESET latching relay or shift register status
F	FUNCTION - specifies a data operation (Series One Plus)
R	REGISTER - specifies a data register or group entry (Series One Plus)

a41 939

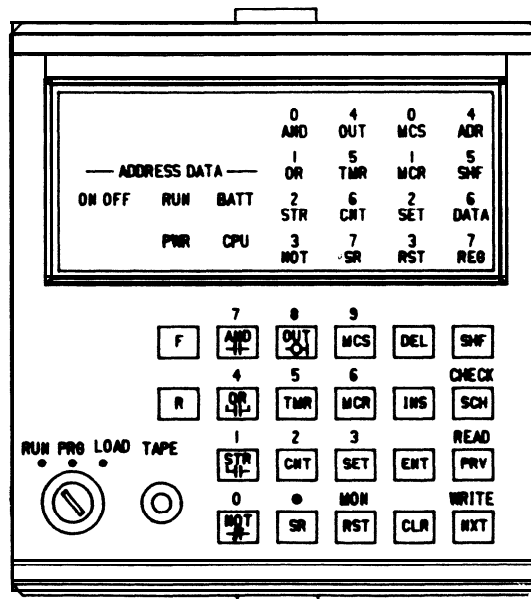

Figure 5-3. Programmer for Series One and Series One Plus

GEK-90842

Basic Ladder Diagram Format

Figure 5.4 illustrates a typical ladder diagram. Between two vertical power rails to the extreme left and right, contacts are placed in horizontal strings or lines. Adjacent lines can be connected between contacts by a vertical line to allow logic to be solved in parallel. The horizontal strings (series) of contacts **are** equivalent to **ANDs**. For example line 1 can be described as: A and B and **C** must occur before coil X is energized; any one reference can prevent the coil from energizing. Similarly vertical contacts are in parallel and programmed as **ORs**. Thus, line 2 is described as: D or **E** or F will energize coil Y. Any one reference can by itself energize coil Y.

In the Series One and Series One Plus PCs, there is no internal limit on how many contacts can be **placed in** series, nor how many in parallel. However, as a practical limit for simple programming **and** system documentation, it is recommended that a horizontal string be limited to nine contacts and one coil; and a vertical array to seven parallel lines.

a42342

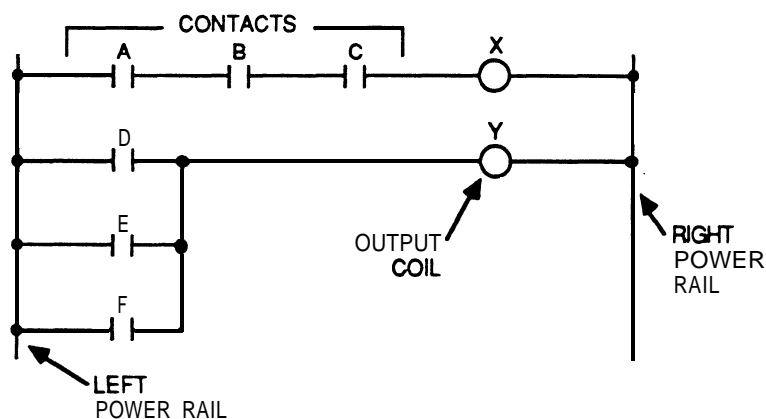

Figure 5-4. Typical Ladder Diagram

Concept of Power Flow

One key feature of PCs is power flow. This is a conceptual flow of power used to visualize the operation of coils, timers, counters etc. Referring again to Figure 5.4, the left hand power rail can be envisioned as “hot” (connected to 115 **V ac** or +24 **V dc**) and the right as its associated “neutral” (connected to 115 **V ac** or -24 **V dc**). **The coils (e.g. X and Y) will be** energized if there is a path for power flow from the left leg to the coil placing the full potential across the coil. If there is no power (electron) flow, the coil will be de-energized (OFF).

Power **always flows from** the left towards the right and will pass through normally open contacts if their references **are** energized (ON) or **normally** closed with de-energized (OFF) references. Power flow is also allowed vertically either up or down between adjacent lines where **parallel connections are programmed**. However, power can NOT flow from right to left at any time through contacts or horizontal shunts. **This** feature **simplifies programming** and prevents undesired sneak **paths**. However, if hard wired **relays are replaced** by a Series One or Series One Plus PC, it is possible some adjustments may be necessary to the logic to either simplify the **programming** or **to** add sneak paths that may be a **basis for the relays functioning**.

Unlimited References

Another difference between PC **programming** and hardwired relays is that any reference such as an input or coil can be used on relay contacts as often as necessary. Since references are merely a unique series of bits in a word of memory, they can be programmed wherever and whenever necessary. Now with PCs, there is no need to count relay contacts and try to limit individual references to four or less contacts; no need to plan to use form C relay configurations to squeeze two contacts **from** one pole. Any reference can be envisioned as a relay controlling many poles providing both normally open and normally closed contacts **that** operate without any time delay from pole 1 (closest to the coil) to pole 1000 (furthest away from coil).

 GEK-90842

SECTION 2

Basic Instructions

Basic Instructions

This group can be considered as the basic building blocks for a relay ladder diagram. The instructions reference discrete bits that are to be part of an operation, that is, a conditional contact or the end of a rung, which could be an output or an internal relay.

How to Begin Programming

The easiest way to begin feeling comfortable with **programming** a Series One or Series One Plus PC, is to enter one rung of logic with contacts in series that control a single coil. Physically connect input devices (pushbutton switches, limit switches, etc) and an output device (such as a lamp) to the corresponding terminals on an input and output module in the PC, turn the inputs on and off, and observe the result on the output device.

Entering a Rung With Series Contacts

In the following program sequence, a rung of ladder logic is shown, then the keystroke sequence required for entering the logic. Notice that when entering a numerical sequence, the SHF key must be depressed before the number or number sequence. In the example, each keystroke is separated by a comma. Numbers with more than 1 digit are grouped together for ease of interpretation.

Turn the mode keyswitch to the PROG (**programming**) position in order to enter the logic.

Enter **two** normally open contacts (1 and 2) in series controlling the state of an output coil (17). Both contacts must be closed to tum on the output.

a40347

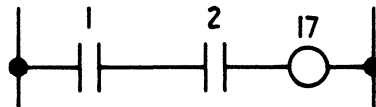

When input devices **wired** to inputs 1 and 2 are closed, output 17 will tum on. The operating state of the inputs and outputs, either ON or OFF, can be monitored by observing the **LEDs** on the Programmer's logic display that **correspond** to the input or output.

Entering the Clear all Memory Sequence

After observing the operation of the series rung, the rung can be deleted by entering the clear all memory sequence, or the rung can remain in memory, with the next rung starting **at** the next memory address. The next memory address, assuming that **the** above rung was entered at address 0000, is **0003**.

If you wish to clear tie contents of memory and start the next rung at address 0000, enter the following key sequence.

CLR, SHF, 348, DEL, NXT

When the clear all memory sequence has been successfully entered, the rung of logic that had been entered will be cleared from memory. (Remember, whenever the clear all memory sequence is entered, **the** entire contents of memory will be cleared).

NOTE

Be sure that you want to clear the complete contents of memory when using this sequence, there is no recovery.

Entering a Rung with Parallel Contacts

Continue the simple program entry by entering a normally open contact (4) in parallel with a second **normally** open contact (20) that references the output coil (20). In series with these, add a normally closed contact (5), then the output coil.

a40347

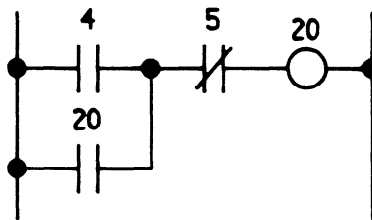

If an input device, such as a limit switch is wired to input 4, and the limit switch is closed, the output would turn on. The normally open contact referencing the output would close and become a seal contact, which would maintain the output in the on state, even if the limit switch wired to input 4 were then opened. The output could be turned off, in this example, by momentarily closing a switch connected to the closed contact, reference 5. Since this is a normally closed contact, it would open when the switch is depressed, and the output would turn off. This logic is commonly used as a motor starter.

Entering a Simple Timer Rung

Next, enter two rungs of logic, the first ending with a timer, having a preset value of 30 **seconds**. The second **rung** has an output controlled by the state of the timer coil. When input 11 is closed, the timer begins **timing** up from 0 towards the preset value of 30 seconds. When the accumulated value of the preset reaches 30, the timer coil will turn on, contact **T605** will close, and output 25 will turn on.

a40347

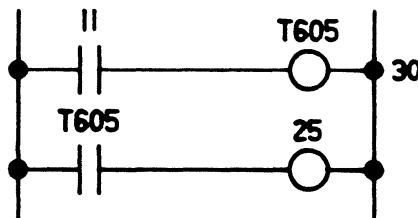

GEK-90842

Basic Relay Logic (Motor Starter)

With this background on the basics of programming a Series One and Series One Plus PC, Figure 5.5 provides a simple example to illustrate relay ladder programming. The references used were selected for illustrative purposes and can be adjusted as necessary to meet your application needs. This is a simple motor starter and seal circuit. An input module is assumed to be installed next to the CPU (005 = start pushbutton input, and 006 = stop pushbutton). Adjacent to the input module is assumed to be an output module (010 = output to motor starter). The program does not care whether these input and output modules are 115 V ac or 24 V dc. The programmer keys to be depressed to enter this logic are also shown in the figure. The start key begins a new rung of logic; this example and most that follow assume an empty memory so the example begins at address 0000.

pc-s1-83-0006

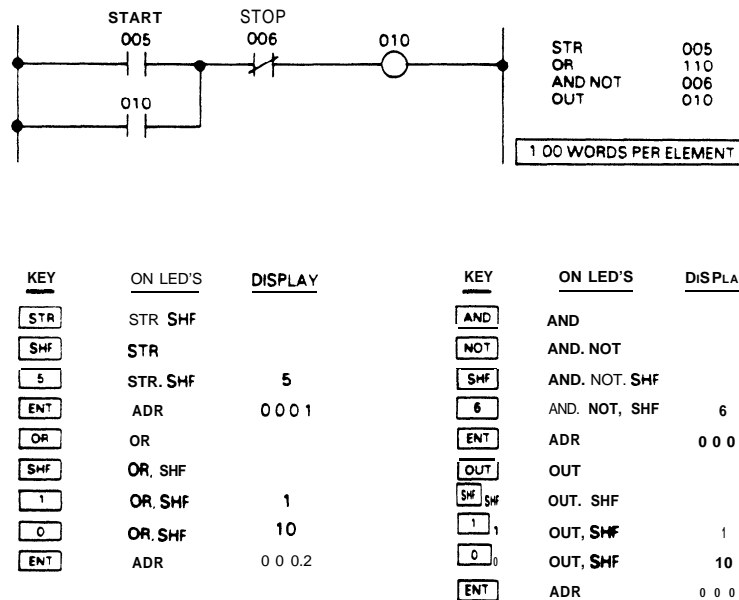

Figure 5-5. Sample Relay Logic (Motor Starter)

Motor Starter Logic Description

The first reference is entered (STR, SHF, 5, ENT) and a normally open contact is established since the NOT key was not depressed. Referring to Figure 5.5, the next function moving from the left (contact 005) to the right along the top line of the logic rung, is a parallel contact referenced as 010. Parallel logic is represented by the OR function, which is selected followed by the desired reference (10) and the Enter key to load the memory. Again moving to the right of the top line, the next contact is in series with the logic completed so far. Thus the ANTI key is selected (for series logic). Since this contact is normally closed, the NOT key is also selected followed by the reference 6 and the Enter key.

The final element of this logic is the coil or output of the rung. Selecting the Output key does not ensure a “real world” output will be generated; it also must refer to an I/O reference and have an output module inserted in the proper slot. To establish the rung output coil, the output key is selected followed by the Shift key, the reference (10) and the Enter key. Outputs can be paralleled by entering additional OUT functions immediately after the initial one.

Normally Closed Input

After completing the logic of Figure 5.5, several features of **programming** should be noticed. First, all elements of the program are entered directly into CMOS memory as the Enter (**ENT**) key is depressed. Thus, if power should be interrupted while a program is being entered or altered, it will be totally saved except possibly for the one element being worked on. Second, there is feedback on the programmer **for all** entries. Something happens (LED ON, display changes, error codes appear, etc) for each key selected. Third, the logic is set up for inputs that are **wired** normally open. If an input is wired normally closed, an adjustment must be made to the symbol (NO or NC) used for that input. Referring to Figure 5.6, inputs sense voltage at their field terminals. They can not detect if a voltage is from a normally open limit switch that is depressed or from a **normally** closed pushbutton that is not depressed. Cover up the two field devices wired to inputs 002 or 003. If you were the input module, and both applied voltage to the field terminals, could you tell which was wired normally closed and which normally open? Because of this, the programmer or system designer must compensate.

pc-s1-83-0007

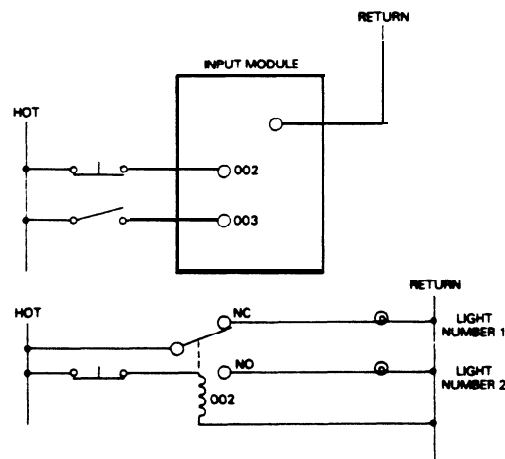

Figure 5-6. Example of Normally Closed Inputs

In a previous discussion, it was stated that inputs are like relays with many poles and you are selecting which type of pole is to be used when you program. In the lower half of Figure 5.6, coil 002 is shown in the de-energized position; however it is wired to a normally closed pushbutton. When you want power to flow if the pushbutton is **NOT** depressed, which contact type do you choose, NO or NC? The answer is normally open since coil 002 is always energized except when the pushbutton is **depressed**. **Therefore, in programming** with the Series One or Series One Plus PCs, a **normally** open contact is appropriate. If the stop button of Figure 5.6 **were wired normally closed, its internal logic** should be normally open to compensate. However, this concept does not normally cause problems for the programmer. **Since PCs are reprogrammable**, if an error is made and discovered when the system is exercised, it is easy to correct

Push-Down Stack

Two very useful functions are programmed using a **2-key** sequence, the AND STR and the OR STR. The AND STR provides a common series connection between a block of logic and the OR STR provides a common parallel connection for a block of logic. These instructions provide the connecting links not allowed with any of the previously mentioned instructions. The logic used with this type of operation is referred to as a push-down stack. The push-down stack can accommodate up to eight levels (groups) of logic. A push-down stack can be thought of as a temporary storage **area** to allow the combining of elements in series (AND) or parallel (OR) connections. **Figure 5.7** illustrates the use of these functions.

a40545

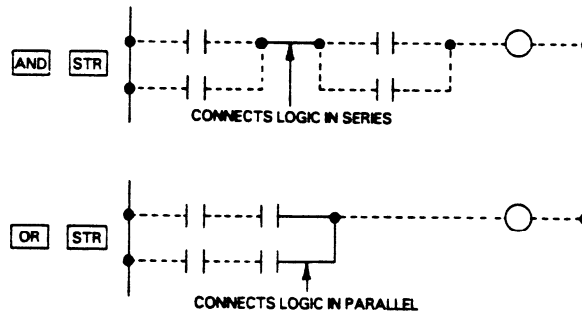

Figure 5-7. AND STR and OR STR Connections

The following pages contain a more detailed description of a pushdown stack and programming with the AND **STR/or STR** instructions.

Detailed Example of AND STR, OR STR

The push-down stack can be used for several groups of contacts, either in series or in parallel, and can be reused many times in the user's logic. As mentioned previously, the stack has eight levels or storage locations where an ON/OFF (1/0) condition is stored.

PUSH-DOWN STACK	
ON (1)	Location 1
ON (1)	Location 2
OFF (0)	Location 3
ON (1)	Location 4
OFF (0)	Location 5
OFF (0)	Location 6
ON (1)	Location 7
OFF (0)	Location 8

Figure 5-8. Push-Down Stack Storage Locations

Description of Operation

There are four basic rules that govern the operation of the push-down stack and they are explained in the following examples.

Rule Number 1: A STR X instruction pushes the contents of each position in the stack down one location. The contents of location number 1 are pushed down to location number 2, the contents of location number 2 are pushed down to location number 3, and so forth. The logical status of reference X is then moved into location number 1 of the stack.

Rule Number 2: The AND Y/OR Y instruction logically ANDs/ORs the status of reference Y (ON/OFF) with the ON/OFF status of location number 1 in the stack and writes the result back into location 1.

AND (SERIES)			OR (PARALLEL)		
	BEFORE LOCATION NUMBER 1	AFTER LOCATION NUMBER 1		BEFORE LOCATION NUMBER 1	AFTER LOCATION NUMBER 1
Y			Y		
OFF	OFF	OFF	OFF	OFF	OFF
ON	OFF	OFF	ON	OFF	ON
OFF	ON	OFF	OFF	ON	ON
ON	ON	ON	ON	ON	ON

Figure 5-9. Push-Down Stack Logical Operations

GEK-90842

Rule Number 3: The **AND STR** or **OR STR** instructions logically AND or OR location number 1 in the stack with location number 2 and writes the result into location number 1. In other words, these instructions put one group of contacts in series or parallel with another group of contacts. This instruction also moves the contents of positions **3** through **8** up one location.

Rule Number 4: An **OUT Y** instruction sets Y to reflect the status of location number 1 in the stack. If the status of location number 1 is **ON (1)**, output Y will be turned off. If the status of location number 1 is **OFF (0)**, output Y will be turned off.

pc-s1-83-0055

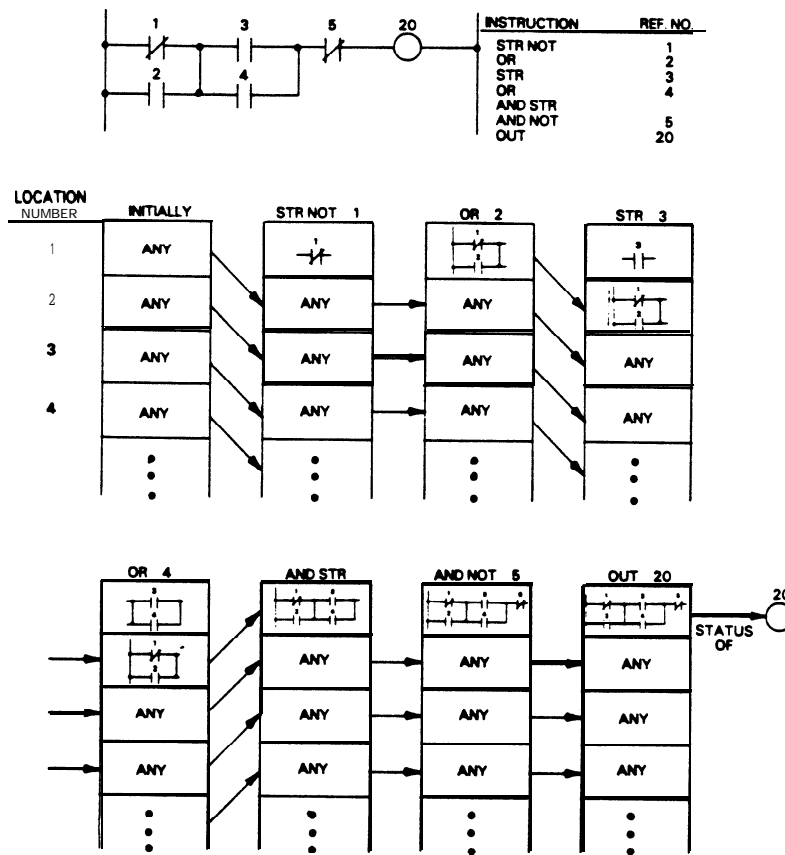

Figure 540. AND STR/OR STR Example Number 1

pc-s1-83-0056

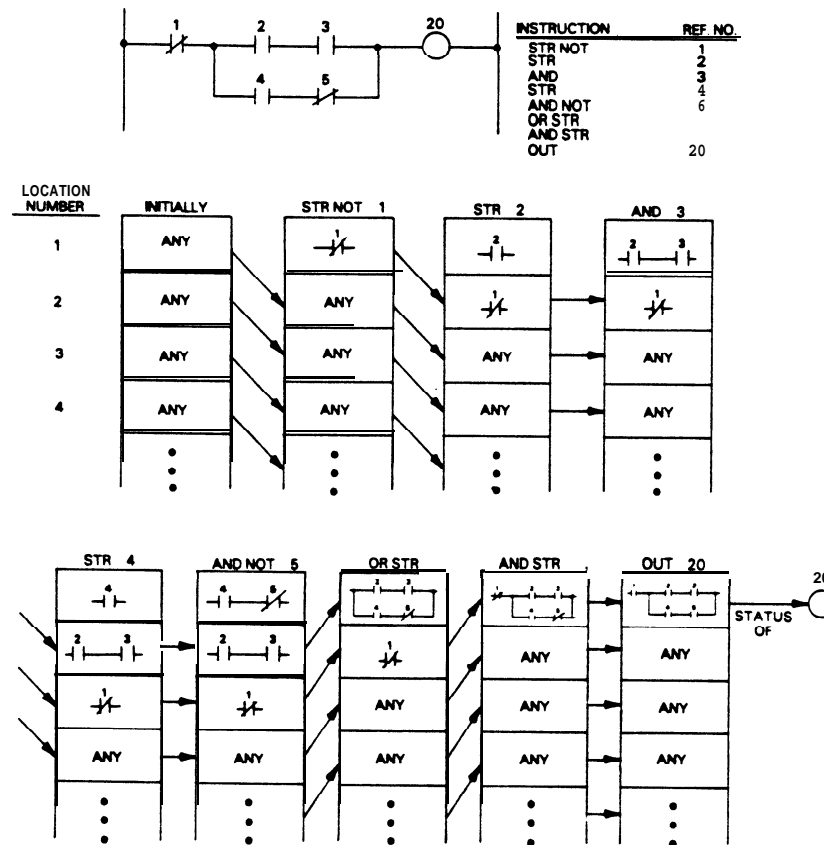

Figure 5-11. AND STR/OR STR Example Number 2

Use of Retentive Coils as Latches

All coils referenced so far have not been retentive upon power failure. Thus if a non-retentive coil is ON when power is removed **from** the CPU, it will be OFF upon reapplication of power (if Switch 1 on the CPU module is **ON**). **There are 28** special coil references (**340-373**) that **are** retained upon power failure. Thus if they were ON prior to loss of power, they will be ON when power is restored; they will be OFF while power is OFF since no scanning is being performed. In addition to these 28 references, latches can be built using shift register references (**400-577**) that are not being used to perform shift register functions. Either retentive coils (**340-373**) or shift registers (**400-577**) can be used to control contacts, both normally open and normally closed wherever required. **This** special retentive function is derived **from** their use as coils to complete or store the results of relay logic rungs.

Programming a Latched Relay

Latches require two separate functions or inputs similar to hard-wired relays, a **SET (turn ON)** and a **RESET (turn OFF)**. **These functions are commonly** referred to as latch and unlatch. If both are active, the last one in the scan will be controlling the state of the coil. To turn on a latch, the function SET

GEK-90842

followed by the retentive coil reference (for example, 340-373 or 400-577) is used instead of OUT, plus the coil number at the end of a logic rung. Once power flows to that coil, it will be energized (turned ON) and remain ON even if power flow to it should be interrupted.

To turn a latch off (de-energize) separate relay logic should be built ending in a RST (Reset) function and the [same] coil number. In many applications, it is useful to allow the system to clear (turn OFF) coils when power fails so that an orderly restart is possible when power is restored, whether that is 2 seconds or several hours, or several days later. Other applications require the control system to remember the status of key items such as part position, operations completed, elevators up or down, etc. The Series One and Series One Plus are provided with both standard and retentive coils to allow the user to tailor the program to fit their requirements.

Figure 5.12 illustrates the programming of retentive (latched) relays. Coil 340 is used only as an example. The logic to either set or reset a retentive coil can be of any convenient size similar to standard coil logic. When power flows through the top rung to the SET coil 340 function, it will be energized and remain ON even if power flow is removed. Anytime the power flows through the lower rung (regardless of path), coil 340 will be turned OFF. Since the set coil 340 is programmed before the reset, it is placed in earlier memory locations and the reset function will have overriding control if they are both energized.

pc-s1-83-0011

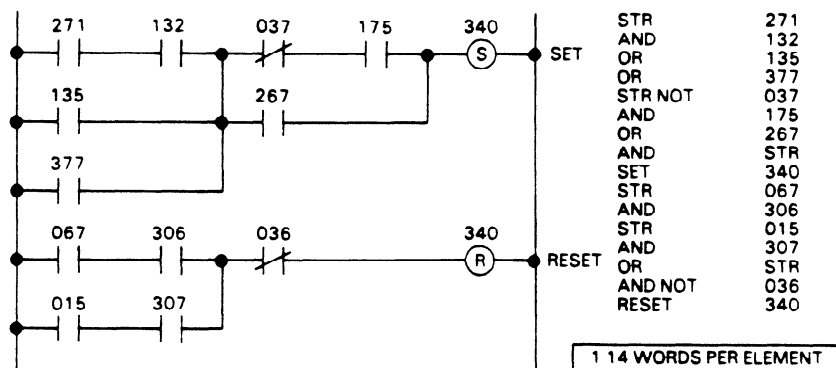

Figure 5-12. Example of Latching Logic

Master Control Relay Functional Description

To control large quantities of coils on a supervisory basis, a Master Control relay function is provided. This function allows an efficient method of programming to turn off large quantities of coils in case some major permissive is not satisfied. One approach would be to incorporate a permissive contact in each rung controlling one of the coils. This may require many contacts and inefficient use of memory. Another method is to bracket those rungs over which master control is desired; this is similar to quotation marks around a direct statement (one at each end to define exactly where the statement starts and where it ends).

The permissive logic is first built starting to the left of the ladder diagram adjacent to the “hot” power rail. Then an MCS (Master Control Start) function is entered, followed by the logic it is to control, and ending with an MCR (Master Control Reset) function. The MCS and MCR are like quotations around the logic to be controlled. When power flows to the MCS, the logic enclosed will operate normally. If

there is no power flow to MCS, the coils will be forced to the OFF state regardless of the internal logic conditions, timers will be reset to zero, and counters will stop (frozen) but not reset. The amount of logic controlled by the Master Control relay function is limited only by the memory provided.

pc-s1-83-0012

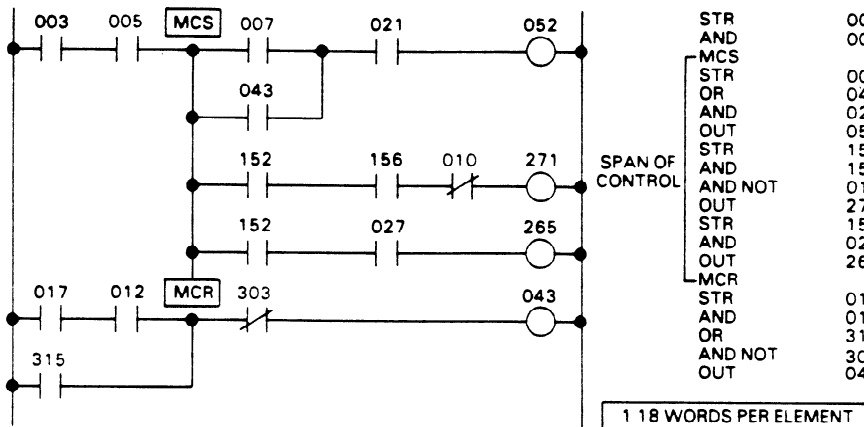

Figure 5-13. Example of Master Control Relay Logic

Programming a Master Control Relay Function

Figure 5.13 illustrates the use of one pair of MCS/MCR functions. In many cases it is convenient to view the MCS function as defining a sub-left power rail whose connection to the main power rail is dependent upon some relay logic. The conditional logic (I003 - I125 in this example) is built first using the normal relay logic. The MCS function is entered without any reference to create the beginning point of the control. Logic is built using normal functions within the control area. Note the duplication of contact 152, which cost only one memory word, there is no need to count or limit the quantity of relay contacts used in PCs. To end the master control, the MCR function is entered returning control to the next power rail to the left and conventional logic can now be built. Unless both references 003 !and^ 005 are energized (ON) in this example, coils 052, 271, and 265 will be OFF. When these contacts are passing power, coils 052, 271, and 265 will respond to their normal logic.

Multiple Master Control Relay Functions

Multiple master control functions are possible in any logic program. They can be embedded within the scope of the first MCS and the last MCR as necessary, as illustrated in Figure 5.14. The first group of coils under the Master Control of references 010 [or] 011 is 204-213 which includes two smaller groups (207-210 and 212-213). Group 207 and 210 are under the Master Control of 010 or 011 and 015, while group 212 and 213 are controlled by 010 or 011 and 022. Note the requirement for two successive MCRs to end both the group 212-213 and the larger group 204-213. To operate correctly there must be an equal number of MCS and MCR functions in your program.

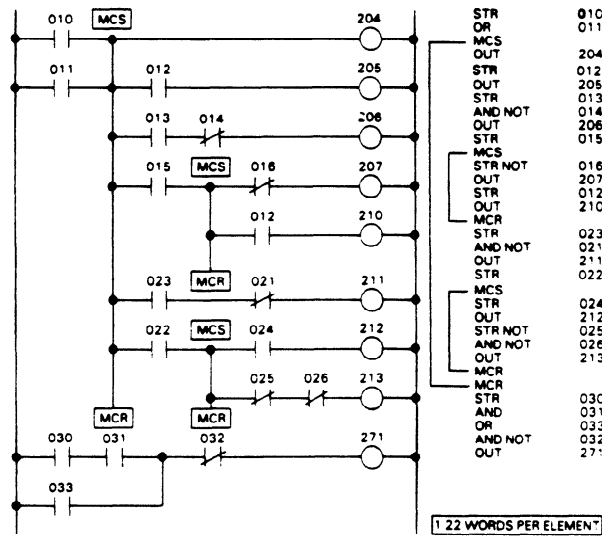

Figure 5-14. Multiple Master Control Relay Logic

Disabling of Outputs

In addition to Master Control functions, all outputs can be affected by an internal special function coil referenced as 376. When this coil is energized by user logic, all outputs in the hardware I/O structure will be turned OFF. Internal coils and statuses will still operate, but only internally. The only exception is to coils that are programmed as SET OUT functions rather than the OUT function. These will still be able to provide their normal output status (ON or OFF) to the I/O section.

Figure 5.15 illustrates the use of coil 376. In this example, when either reference 003 or 056 (inputs, outputs, or internal depending upon hardware I/O configuration) is energized, coil 376 will also be energized. This will cause all coils programmed with the OUT function, such as 010, to be turned OFF at their output module, although they will function normally internally. However, coils driven by the SET OUT function, such as 011, will not be affected by the status of coil 376. Table 5.7 summarizes the effect of coil 376 on the OUT and SET OUT functions.

NOTE

It is not recommended that the Output Disabler coil (376) be used with retentive coils (latches).

Table 5-7. Effect of Coil 376 (Output Disabler)

Internal Status	Coil 376 OFF		Coil 376 ON	
	Out	Set Out	Out	Set Out
OFF	OFF	OFF	OFF	OFF
ON	ON	ON	OFF	ON

pc-s1-83-0014

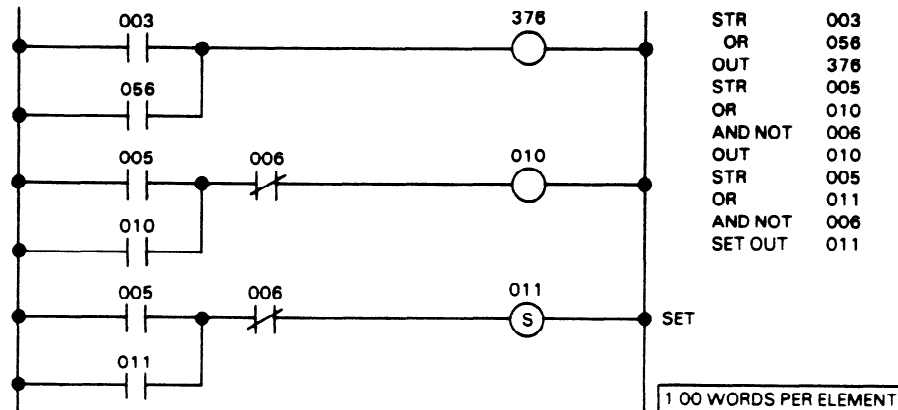

Figure 5-15. Sample Coil Disabler Logic

Timer and Counter Functional Description

In addition to relay logic, there are a wide variety of functions that are standard with the Series One and Series One Plus. Timing and Counting are two of the most commonly used non-relay functions. These functions are special coils using references 600-677. Up to 64 total timers and/or counters can be built within the Series One or Series One Plus. They end a rung of logic similar to using an OUT function for relay logic. Unlimited contacts, both normally closed (timed OFF delay) and normally open (timed ON delay) can be referenced to any timer/counter coil. A preset value is used to indicate how many seconds, tenths of seconds, or counts, the function should delay before energizing its coil. When the coil is energized, time or counts continue to be recorded. All presets can be up to four decimal digits (0001 to 9999), which allow timers to be set from 0.1 to 999.9 seconds, and counters from 1 to 9999 counts. Timers can be set from 0.01 to 99.99 seconds with the Series One Plus 3.7K PC only. Timers are set to a .01 second duration by setting output reference 770 (SET 770). Caution must be used when doing this, since reference 770 being reset in the same program would cause the timers to revert back to .1 second duration.

Special Timer/Counter References

The four references 674-677 obtain their presets from external thumbwheels via the thumbwheel interface. Additionally, a Timer/Counter Setpoint unit can be used with the Series One Plus to enter the preset values. When a preset value is selected with the Timer/Counter Setpoint unit, the values are simultaneously entered into 8-bit registers, (two registers for each 4-digit BCD value). The registers can then be used to specify the preset value for any Timer or Counter. It should be noted that only 1 Thumbwheel Interface unit or 1 Timer/Counter Setpoint unit can be used with a series One Plus PC, not both at the same time. These four references cannot use internal presets; however, they will count up to 9999 and can be used to drive sequencers without the thumbwheel interface.

Programming Timers

Timers (Figure 5.16) can be programmed in either seconds or tenths of seconds (or hundredths of seconds with a Series One Plus 3.7K PC) and require only one line of logic to control their operation. When power flows to the timer coil, it will begin recording time at the rate of one count every 0.1

GEK-90842

seconds or .01 seconds as applicable. The timer starts at 0000.0 and records time, towards the preset value. When the preset value is reached, an event will happen according to what has been programmed. Also, when the timer reaches the preset value, the timer will continue timing up, until reset by an interruption of power flow through its conditional contacts, or until it reaches its maximum value of 999.9 or 99.99, as applicable at which time it will stop. If power flow to a timer is interrupted or if the CPU should stop operating, the timer will be reset to zero. The basic clock driving all timers derives its accuracy from a crystal within the CPU, it does not depend upon the AC power line frequency.

pc-s1-83-0015

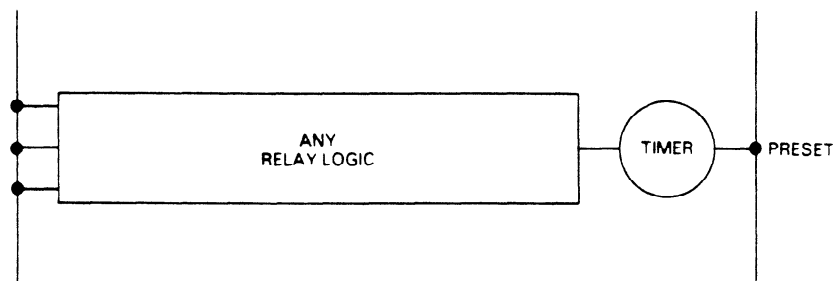

Figure 5-16. Sample of Timer Logic

A timer can be programmed to be self resetting, by programming a closed contact referencing the timer coil. If programmed in this manner, when the preset value is reached, the timer coil will turn on, the closed contact referencing the coil will open and the timer will reset to 000.0 and start timing up again.

Figure 5.17 illustrates the programming of various types of timers. The relay logic is built in the normal manner up to the coil selection. The timer (TMR) function is selected along with a timer/counter reference (600-677). Each timer or counter must have its own unique coil to operate properly. After the timer is identified, the preset is entered.

In this example, coil 41 will be OFF until 15 seconds after timer 601 is energized. It will remain ON until either the power flow to 601 is interrupted or the CPU goes through a power up operation. Coil 42 is inverted from 41 in that it stays ON until 15 seconds after power flows continuously to the timer 601, when it goes OFF. Timer 602 delays 5.5 seconds after reference 27 is energized before it turns its coil ON, also energizing coil 43.

Specifying Timer Preset Values

The Timer preset value can be either a fixed value entered after the T/C reference, the BCD value entered with the Timer/Counter Setpoint unit for the special Timer/Counter references (674-677), or the value in the registers that are assigned to the special Timer/Counter references. These registers are 564 and 565 for T/C reference 674; 566 and 567 for T/C reference 675; 570 and 571 for T/C reference 676; and 572 and 573 for T/C reference 677.

The preset value information is also valid for Counters.

a40016

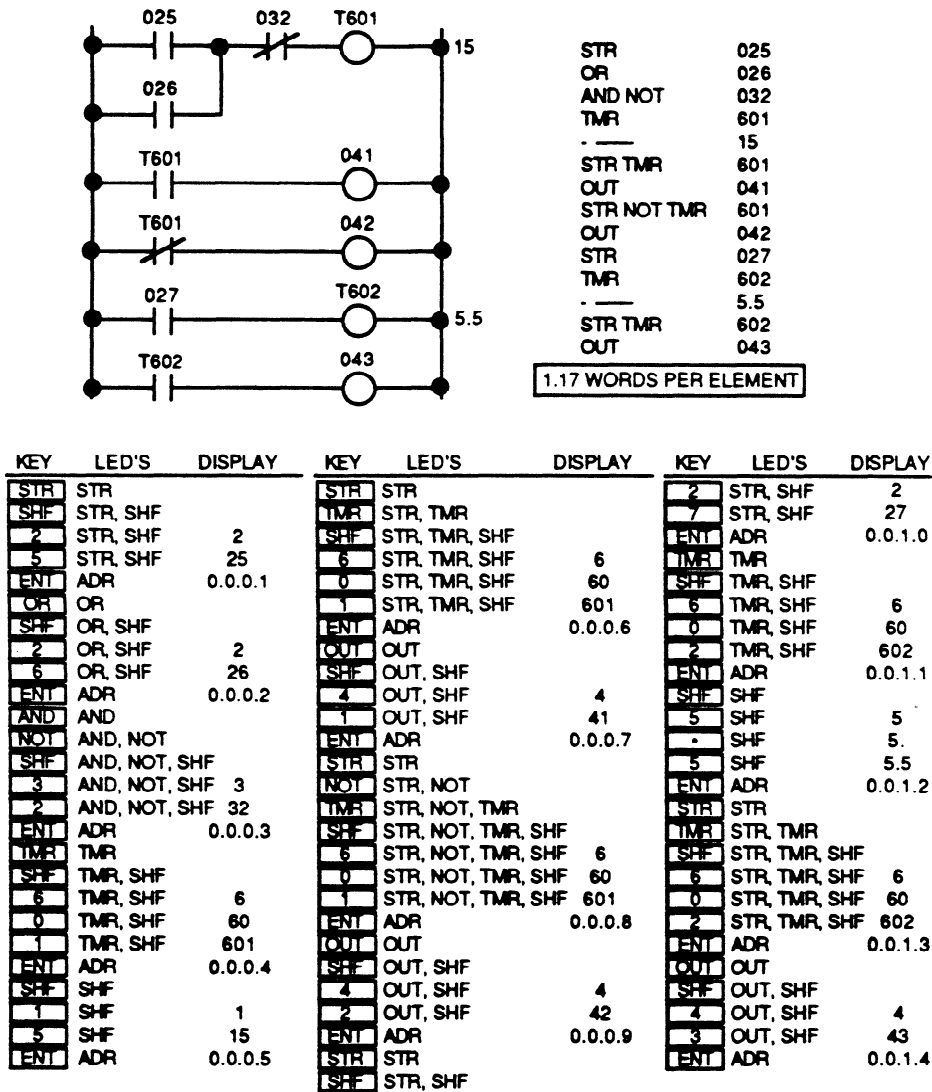

Figure 5-17. Example of Timer Logic

Programming Counters

Counters (Figure 5.18) operate similar to timers except that they require two rungs of relay logic to control their operation. The upper rung controls when the counter is incremented. When this rung goes from no power-flow to power-flow (OFF to ON), the counter is incremented by one. To cause another count to be recorded, power-flow must be interrupted and another OFF to ON transition must occur. All counters count up, starting at zero, towards a preset value. The ability to detect transitions and record counts is built into the counter function and requires no further programming by the user. The lower rung of logic (second STR function) controls the reset of the counter function. Whenever this rung supplies power flow to the counter, the counter will be reset to zero. If both rungs supply power flow, no

GEK-90842

counts are recorded and the counter is forced to zero. All counters are retentive upon loss of CPU power.

pc-s1-83-0017

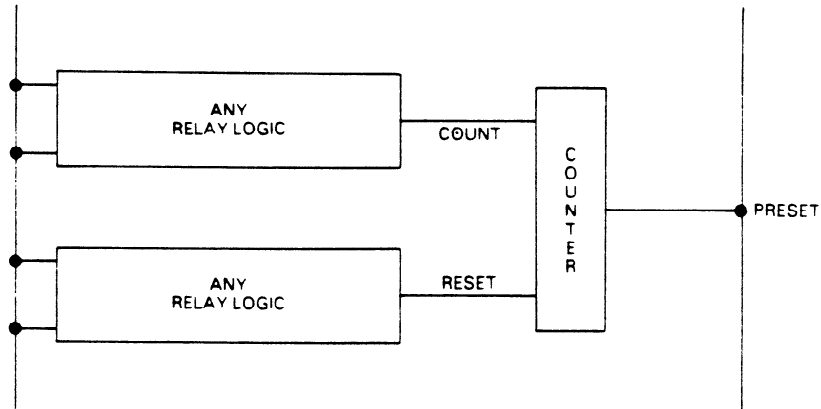
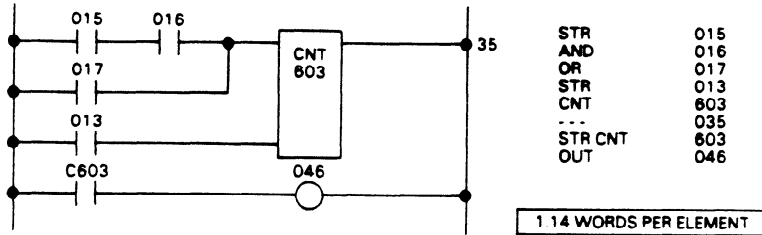

Figure 5-18. Example of Counter Logic

Figure 5.19 illustrates the operation of counters. Again, the relay logic driving the counters is built as separate rungs using normal relay programming techniques. Counter 603 will count (increment) whenever references 015 and 016 are both ON or reference 017 is ON. If one parallel path is energized while the other is also ON, no additional count is recorded. When the count reaches 35 (its preset), coil 603 is energized, also energizing coil 46. Counting will continue beyond the preset value, and will continue counting until the counter is reset. Whenever reference 013 is energized, regardless of the count or top rung status or coil state, counter 603 will be reset to zero and held at that value until reference 013 is de-energized.

pc-s1-83-0018



KEY	ON LED'S	DISPLAY	KEY	ON LED'S	DISPLAY	KEY	ON LED'S	DISPLAY
STR	STR		STR	STR		STR	STR	
SHF	STR, SHF		SHF	STR, SHF		CNT	STR, CNT	
1	STR, SHF	1	1	STR, SHF	1	SHF	STR, CNT, SHF	
5	STR, SHF	15	3	STR, SHF	13	6	STR, CNT, SHF	6
ENT	ADR	0 0 0 1	ENT	ADR	0 0 0 4	0	STR, CNT, SHF	60
AND	AND		CNT	CNT		3	STR, CNT, SHF	603
SHF	AND, SHF		SHF	CNT, SHF		ENT	ADR	0 0 0 7
1	AND, SHF	1	6	CNT, SHF	6	OUT	OUT	
6	AND, SHF	16	0	CNT, SHF	60	SHF	OUT, SHF	
ENT	ADR	0 0 0 2	3	CNT, SHF	603	4	OUT, SHF	4
OR	OR		ENT	ADR	0 0 0 5	6	OUT, SHF	46
SHF	OR, SHF		SHF	SHF		ENT	ADR	0 0 0 8
1	OR, SHF	1	3	SHF	3			
7	OR, SHF	17	5	SHF	35			
ENT	ADR	0 0 0 3	ENT	ADR	0 0 0 6			

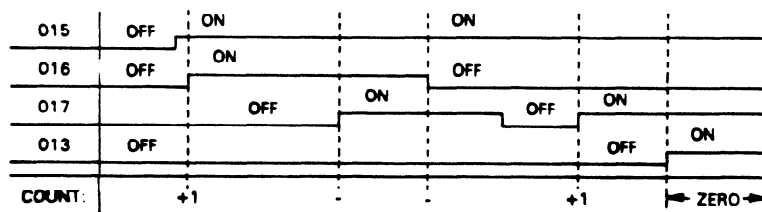

Figure 5-19. Example of Counters

Extending the Timer and Counter Range

Timers and counters can be connected in series or cascaded to extend their range beyond four digits. Figure 5.20 illustrates several techniques to extend preset ranges by utilizing multiple timer/counter

GEK-90842

functions. Timer 611 will record time as soon as references 206 and 225 are energized. After 800 seconds it energizes its coil and stops recording time. However, timer 612 starts as soon as 611 reaches its preset and continues for another 950 seconds. This is a total of 1750 seconds from the time T611 started. Whenever reference 206 or 225 is de-energized, timer 611 is reset to zero, de-energizing coil 611, and also resetting timer 612 (if necessary).

pc-s1-83-0019

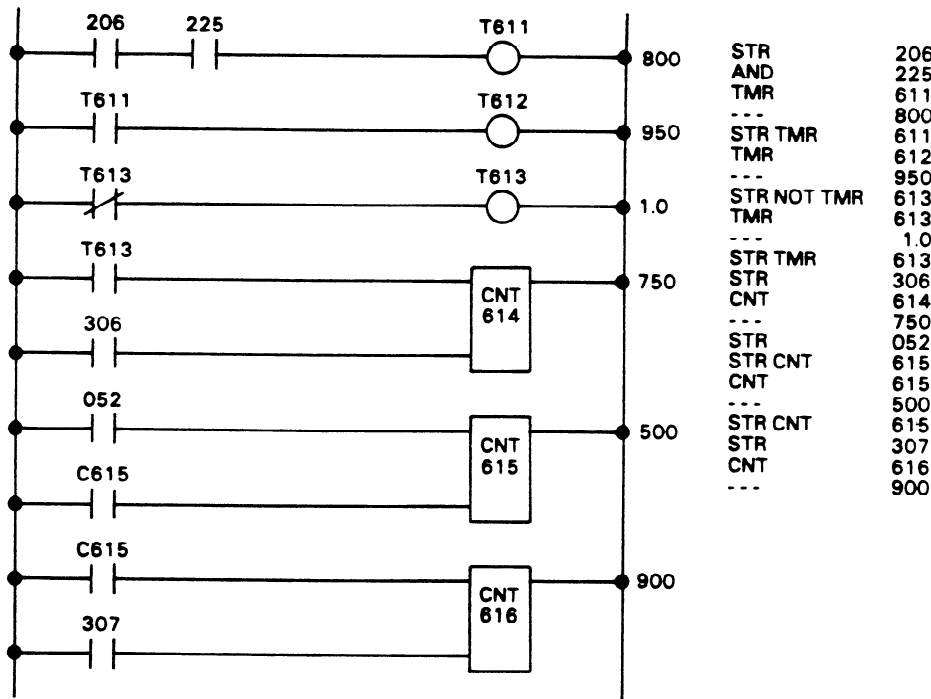

Figure 5-20. Example of Extended Counters

Another pair of functions are timer 613 and counter 614. Timer 613 is a self resetting timer with a preset of one second (10 tenths). It produces outputs each one scan long, every second from the time the CPU starts until it is turned OFF. Counter 614 counts these pulses up to 750 of them (750 seconds) until reset by reference 106. Since counters are retentive, using timer 613 to produce a one second clock that is counted by 614, results in a retentive timer. A similar result occurs if the top rung of counter 614 were referenced to internal coil 375 in lieu of 613. The third example in Figure 5.20 is counters 615 and 616. Counter 615 counts reference 52, up to 500, and then resets itself. Counter 616 records how many of these groups of 500 counts occur. Since counter 616 has a preset of 900, its coil will be energized only after 450,000 transitions of reference 52. At anytime, counter 615 has a representation of the small number of counts (0-499 or least significant portion) and counter 616 the larger values representing multiples of 500 (500-450,XXX) or most significant portion. Application techniques shown in Chapter 8 illustrate how a low order preset of 1000 can be obtained to produce a more conventional double precision counter.

Sequencer Operation

All Series One and Series One Plus counters have one other very powerful feature which is applicable to all counters. They all can be programmed to act as sequencers. Each counter can control a 1000 step sequencer, which allows any Series One or Series One Plus PC to have sixty four 1000 step sequencers, each similar to a stepping switch or drum sequencer. Figure 5.21 illustrates the operation of one of these sequencers. Each sequencer moves from one position to the next as directed by some user defined signal shown here as a pushbutton. Counters move or are incremented once each time a count is recorded. Each sequencer starts at zero or home position when the counter is reset, and progresses through its steps one at a time in numerical order. At any time the position of the sequencer can be determined by the current count value contained in its storage. Although any sequencer can have up to 1000 steps, many applications are solved with a smaller number. To limit a sequencer to less than 1000 steps, the preset on the counter is used. As usual, each step of the sequencer can control any number of contacts.

pc-s1-83-0020

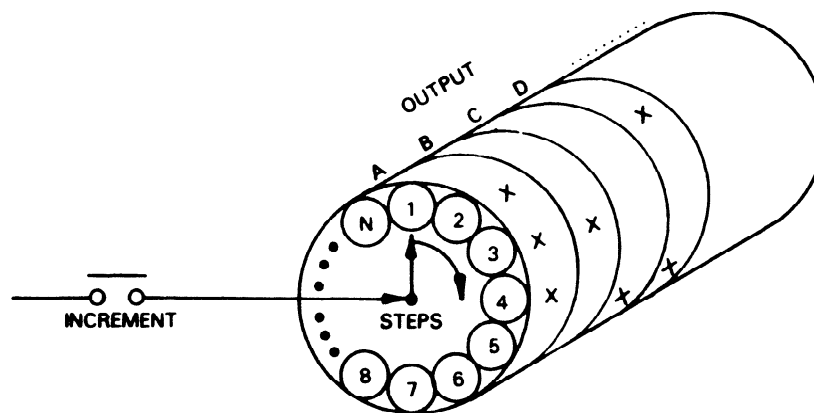

Figure 5-21. Illustration of Sequencer Operation

To illustrate the capabilities of the sequencer, refer to the example in Figure 5.22. The sequence map in this example is in the form of a timing diagram that has an overall cycle of 45 seconds. This time is subdivided into increments of 5 seconds per the requirements of this application. There are six outputs to be controlled during the sequence with the desired ON periods shown by horizontal black lines. Outputs are assigned and step numbers (starting at zero) are entered for each time period. To drive the sequencer (Figure 5.23), a timer (600) is entered to reset itself each 5 seconds. Input 030 is used to control the sequencer, which will not be incremented except when this input is energized. When energized, timer 600 will produce one pulse every 5 seconds. Counter 601 increments its count once each pulse, thus stepping the sequencer. Input 031 will reset the sequencer to home (zero) whenever it is energized, regardless of the count or position of the sequencer. The counter will go up to eight and then stop waiting for a reset signal.

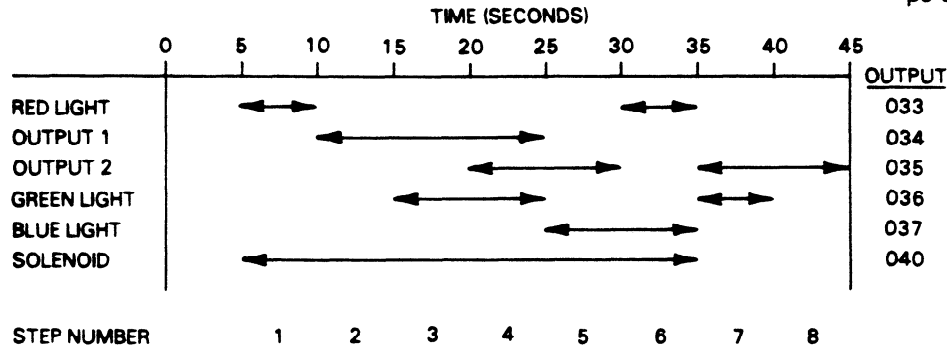

Figure 5-22. Example of Sequencer

The outputs from the sequencer are programmed using relay logic. However, the reference is first to the counter (601) controlling the sequencer and then to the current value that is going to control that contact. For example if a reference to counter 601 is desired that will pass power only when that counter has a current count of exactly one, the value 1 is entered after the reference to 601 on a normally open contact.

In this example, output 033 (red light) will be energized during 5 second intervals each for steps 0, 1, and 6. Similarly, output 034 (Output 1) will be energized at step 2, sealed and held until the beginning of step 5 (end of step 4). The other outputs are controlled using similar logic with parallel contacts or seal-in circuits.

If an output is ON for more steps than it is OFF, normally closed contacts would probably simplify your logic. Counters can also be used that are driven independently and not with a time base.

Referencing Sequencer Contacts with a Series One Plus PC

When programming a Counter or Shift Register in a Series One Plus or Series One Plus 3.7K PC that has the IC610CPU105 CPU installed, a Drum Sequencer contact reference should not be used as the first contact (with a STR or STR NOT instruction) in the COUNT or RESET rung of a counter or the DATA, CLOCK, or RESET rung of a Shift Register. If a program using the step described above was entered into a Series One PC having an IC610CPU101 CPU (this would work correctly) and written to Tape, then later transferred to a Series One Plus PC with an IC610CPU105 CPU or a Series One Plus 3.7K PC with an IC610CPU106 CPU, the program would not execute properly.

Do not reference a Drum Sequencer step as the first contact in the rungs as described above. If a Drum Sequencer step is required as the first contact reference for a rung in a Counter or Shift Register, a programming technique that would work properly is to use the required Drum Sequencer step to turn on an internal coil in a separate rung, then reference that coil as the first contact in the Counter or Shift Register rung.

Printer Interface Unit
CROSS REFERENCE PRINTOUT

OUTPUTS USED TABLE V2. 2

SERIES ONE, ONE PLUS/SR-20, SR-21

PAGE 0007

SHIFT REGISTER

400:	410: *	420: *	430: *	440:	450:	460:	470:
401:	411: *	421: *	431: *	441:	451:	461:	471:
402:	412: *	422: *	432: *	442:	452:	462:	472:
403:	413: *	423: *	433: *	443:	453:	463:	473:
404:	414: *	424: *	434: *	444:	454:	464:	474:
405:	415: *	425: *	435: *	445:	455:	465:	475:
406:	416: *	426: *	436: *	446:	456:	466:	476:
407:	417: *	427: *	437: *	447:	457:	467:	477:

500:	510:	520:	530:	540:	550:	560:	570:
501:	511:	521:	531:	541:	551:	561:	571:
502:	512:	522:	532:	542:	552:	562:	572:
503:	513:	523:	533:	543:	553:	563:	573:
504:	514:	524:	534:	544:	554:	564:	574:
505:	515:	525:	535:	545:	555:	565:	575:
506:	516:	526:	536:	546:	556:	566:	576:
507:	517:	527:	537:	547:	557:	567:	577:

TIMER/COUNTER

600:	610:	620:	630:	640:	650:	660:	670:	100:
601: *	611:	621:	631:	641:	651:	661:	671:	101:
602:	612:	622:	632:	642:	652:	662:	672:	102:
603: *	613:	623:	633:	643:	653:	663:	673:	103:
604:	614:	624:	634:	644:	654:	664:	674:	104:
605:	615:	625:	635:	645:	655:	665:	675:	105:
606:	616:	626:	636:	646:	656:	666:	676:	106:
607:	617:	627:	637:	647:	657:	667:	677:	107:

Figure 4-8. Sample Outputs Used Table Printout

Printer Interface Unit
CROSS REFERENCE PRINTOUT

OUTPUT REGISTERS USED TABLE V2. 2

SERIES ONE PLUS/SR-21

PAGE 0006

OUTPUT

000:	001:	002:	003:	004:	005:	006:	007:	010:	011:	012:
013:	014:	015:		070:	071:	072:	073:	074:	075:	076:

INTERNAL RELAY

016:	017:	020:	021:	022:	023:	024:	025:	026:	027:
030:	031:	032:	033:	034:	035:	036:	037:		

SHIFT REGISTER

040:	041:	042:	043:	044:	045:	046:	047:
050:	051:	052:	053:	054:	055:	056:	057:

DATA REGISTER

400:	410:	420:	430:	440:	450:	460:	470:
401:	411:	421:	431:	441:	451:	461:	471:
402:	412:	422:	432:	442:	452:	462:	472:
403:	413:	423:	433:	443:	453:	463:	473:
404:	414:	424:	434:	444:	454:	464:	474:
405:	415:	425:	435:	445:	455:	465:	475:
406:	416:	426:	436:	446:	456:	466:	476:
407:	417:	427:	437:	447:	457:	467:	477:
500:	510: *	520:	530:	540:	550:	560:	570:
501:	511: *	521:	531:	541:	551:	561:	571:
502:	512:	522:	532:	542:	552:	562:	572:
503:	513:	523:	533:	543:	553:	563:	573:
504:	514:	524:	534:	544:	554:	564:	574:
505:	515:	525:	535:	545:	555:	565:	575:
506:	516:	526:	536:	546:	556:	566:	576:
507:	517:	527:	537:	547:	557:	567:	577:

Figure 4-9. Sample Outputs Used Table Printout (continued)

pc-s1-83-0022

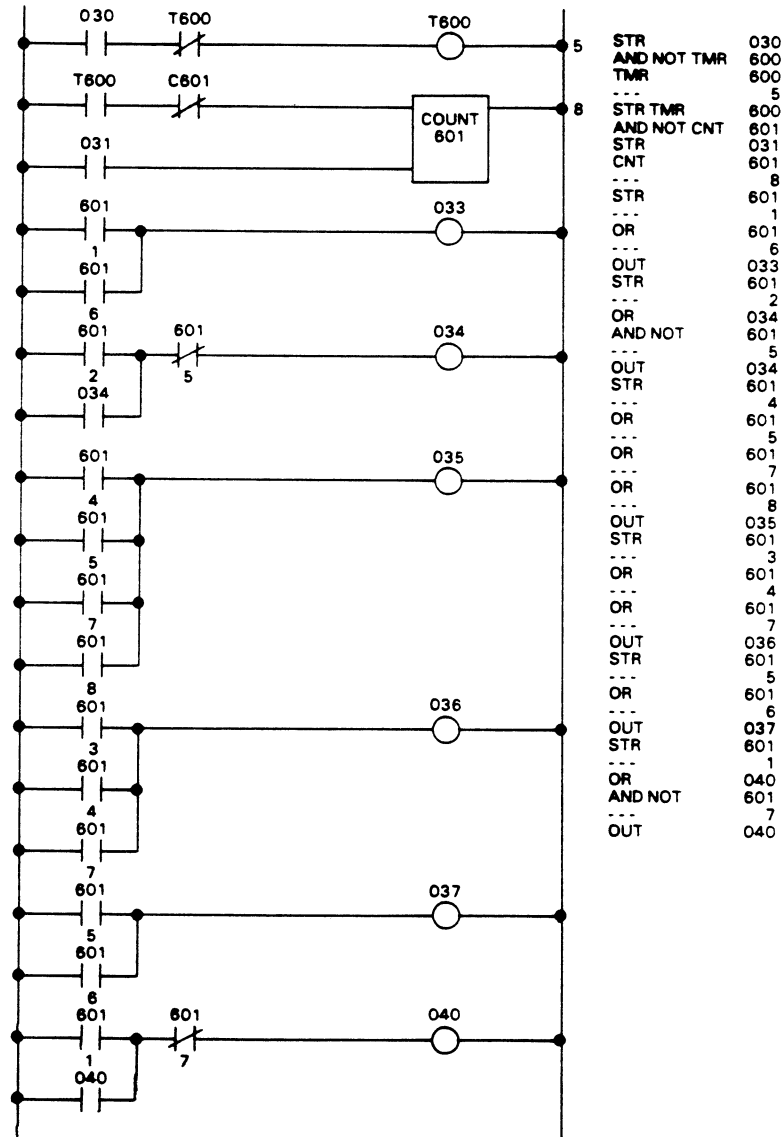

Figure 5-23. Typical Sequencer Logic

Shift Register Functional Description

Another powerful feature of all Series One and Series One Plus PCs is the ability to simulate the operation of shift registers. There are many physical devices that operate similar to shift registers such as an anchor chain, a conveyor belt, an indexing machine, a line of customers at a refund desk, etc.

GEK-90842

There are several common features that can be used to describe the generalized features of a shift register. There is movement in all examples, normally in one direction. This movement can be defined as a group of fixed increments such as one link, one box position, one operation, or one person. The 2 order 1 of activities (pulling chain in, placing boxes on conveyor, loading parts to be worked on/tested, or adding people to the line) normally remains the same - first in, first out. In case of power failure in the plant or building, it is desirable that the shift register retain its content (part position, people order, boxes on conveyor, etc). However, in many cases it is also desirable that under logic control, the shift register be cleared such as start up on Monday morning. It is much easier for the user to clear a retentive shift register than it is to restore a cleared (volatile) content.

pc-s1-83-0023

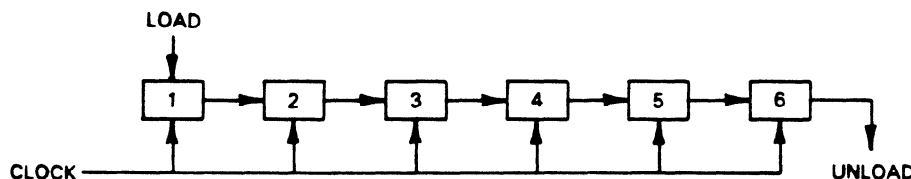

Figure 5-24. Typical Shift Register

A shift register is a group of storage locations that are synchronized by a timing or clock signal. Figure 5.24 illustrates the operation of a typical shift register with six stages. Each stage can store a single bit which can represent a good or bad part, part or no part, ON or OFF, a one or zero, etc. Data is loaded into the first stage, incremented through the shift register one position per clock pulse, and then out the other end. When the clock signal goes from OFF to ON, each stage shifts one position towards the right. The content of stage 6 is unloaded, stage 5 content moves into stage 6, stage 4 into 5, etc. until stage 1 moves into stage 2. Stage 1 is then cleared, awaiting a load signal from another logic.

Within the Series One and Series One Plus, there are 128 retentive storage locations for use with shift registers. Since the Series One family logic functions are easy to use yet provide the user with unmatched flexibility, they allow many separate shift registers to be built of various lengths as long as the total quantity of stages does not exceed 128.

Each shift register requires several pieces of information to perform its function. Since it is a serial operation, there must be a definite beginning and a similar ending. At the start of an operation parts are put into the machine or boxes are put on the conveyor. A signal is required to indicate when a part is to be placed into the shift register at stage one. Similarly, there is a signal that indicates when the shift register should increment or move one position. The third and last signal is one to indicate when the shift register (all stages) should be cleared to zero or OFF conditions.

Shift Register References

The definition of size for any shift register requires the user to define how many stages are desired, and which references are assigned to this function. The size of the shift register is usually established by the maximum size of the physical device it is controlling. For example, how many links are in the chain, how many boxes can be placed on the conveyor, how many positions has the index machine, or how many people is there space for? The references to stages of the shift registers within the Series One and Series One Plus are to the references 400 through 577. Each stage or position of any shift register should be unique. Storage locations should not be shared between different shift registers. However, multiple logic functions can be programmed to operate upon one shift register to produce bi-directional

shift registers, ring counters, First In First Out or Last In First Out stacks. Each shift register reference can control any number of relay contacts, both normally open and normally closed.

Shift Register Operation

To illustrate the operation of serial shift registers, Figure 5.25 defines a theoretical problem using a sequential assembly machine. The machine has space for a maximum of 12 parts at any one time. These parts may be cups or other storage locations physically on the machine. The operations are performed while the machine is stationary and then all storage locations (cups) are indexed rapidly one position towards the right. There are three separate operations such as part assembly, welding, clamping, nuts tightened, painting and label placement, etc. Since it would be a waste of material and machine time to operate on locations without a part in place, there is a sensor on the first location to detect when a part is present. To the right is a testing position to determine good parts and bad parts for later separation. Each position of the machine is assigned a number for later reference to the shift register. Notice that positions 3, 5, 7, 10, and 12 are only holding locations to store parts in progress and are related to the mechanical layout of the machine.

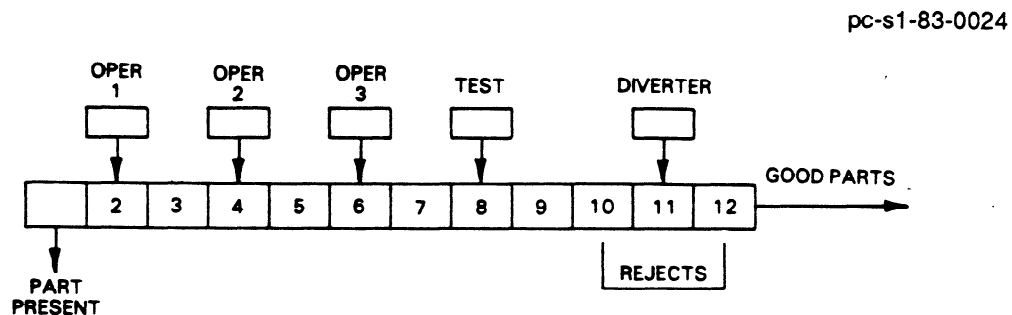

Figure 5-25. Example of Shift Register

Figure 5.26 illustrates the logic, including shift register, used to solve this problem. The following I/O references are assigned for use in this logic and can be changed as necessary to fit your application.

Part Present (Input)	045
Test OK (Input)	046
Reset/All (Input)	047
Operation 1 (Output)	130
Operation 2 (Output)	131
Operation 3 (Output)	132
Test (Output)	133
Diverter (Output)	134
Shift Permissive (Internal)	214

The timing of each operation allows the machine to index one position each 3 seconds. Thus timer 631 produces an output every 3 seconds as long as the internal permissive is satisfied. This coil (214) is developed elsewhere and indicates all operations have been completed and hardware is out of the way, allowing movement without damaging the machinery. The shift register itself has three parallel rungs each of which can be any combination of series and parallel contacts. The first is the input signal. Whenever this is supplying power flow the first stage of the shift register will turn ON and remains ON

GEK-90842

even if the input changes. The middle rung is the clock signal controlling the shifting of all stages. When this signal goes from OFF (no power flow) to ON (power flow), all stages will shift one position. This shifting is completed before other logic is solved. The bottom rung is the reset signal. Whenever this signal is supplying power flow, (all) stages of the shift register will be turned OFF (cleared).

The references used by this shift register and thus the number of stages, must be defined. The reference for the shift register itself is the location of the first stage and immediately following that is the reference for the last stage of that shift register. In our example, input 045 indicates a part present and loads the first stage (431) of the shift register.

Timer 631 (3 seconds) and coil 214 (permissive to shift) are both required before the shift occurs. Finally, input 047 is used to clear all shift register stages perhaps at the start of machine operation or otherwise under operator control. The shift register is built using references 431 through 444 (total 12 stages). The remaining relay logic merely connects the individual stages of the shift register to their output to exercise proper control. The only exception is the next to the last rung. This rung receives the test signal and resets stage 440 if the test is passed. Thus when the later stage (443) receives the data, it will not activate coil 134 to operate the diverter. Therefore, good parts are passed and the diverter operates only for bad parts, not for empty locations or good parts.

a42154

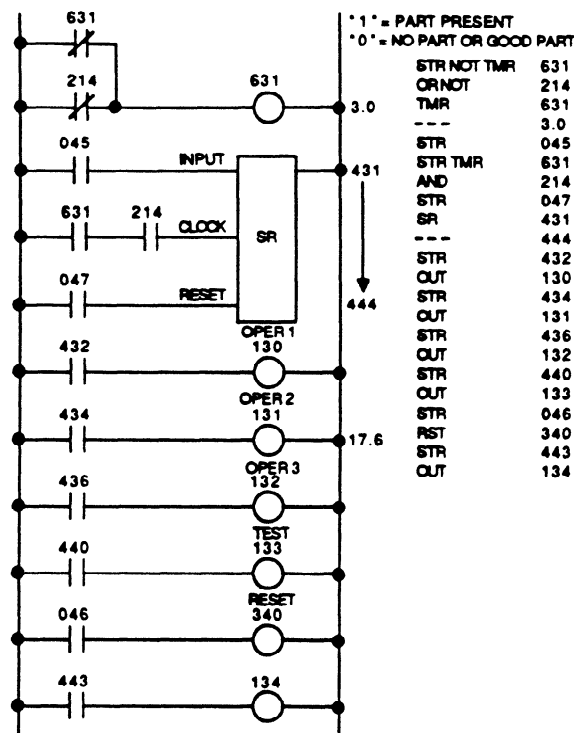

Figure 5-26. Example of Shift Register Logic

Normally many parts will be processed through this machine, continuously moving from input at position 1 to output from position 12. However, for the purpose of illustration, a single part will be examined as it moves down the machine. The part is placed in position 1, energizing input 045 and setting shift register stage 431. After three seconds, timer 631 energizes clocking the shift register causing the ON state for this part to move into stage 432. Then timer 631 will reset itself and stage 431 is cleared. When stage 432 is energized so is output 130 causing operation one to be performed on this part. An additional three seconds pass and another clock cycle causes the ON to move to stage 433. Stage 432 will be loaded from 431 which is OFF as long as additional parts are not processed. The above discussion assumes no delays are experienced with the permissive.

The above operation repeats itself as the part goes through 434 (operation 2), 435 (rest), 436 (operation 3), 437 (rest), and 440 (test) at three second intervals. While at the test position, output 133 is energized and the test OK input (046) is expected. If the part passes the test, input 046 will reset stage 440 making the remainder of the shift register act as if no part was present and allowing the part to pass straight on through. However, if the test is not passed, the ON stage moves to 441, 442, and 443 at three second intervals. At stage 443, it energizes output 134 causing the diverter to push off the defective part into the reject bin.

Other logic can be added to improve the capabilities of this program. For example, a timer could measure the delay from the manual cycle (631 energized) and receipt of the permissive (214). It would also alarm if this delay was excessive such as 5 or 8 seconds beyond the normal 3 seconds. Counters could also be installed to record both good and bad parts produced. This data can be readout and reset via the programmer whenever desired, such as each shift, day, week, etc.

Forcing I/O References

An invaluable tool in the verification of user logic and field wiring is the ability to force I/O references. The operation of the I/O forcing operation is dependent on the I/O reference being forced. Inputs connected to external devices can be forced on or off for one solution of user logic. All other I/O references can be forced on or off indefinitely, but are overridden by user logic.

The most frequent user of the I/O forcing function is for verification of field wiring of outputs. Since user logic overrides the I/O forcing function it is recommended that this operation be performed with user program memory cleared. The key sequences for forcing I/O references are as follows:

- To force a specific I/O reference ON, enter the sequence: SET, SHF, XXX (I/O) reference), ENT.
- To force a specific I/O reference OFF, enter the sequence: RST, SHF, XXX (I/O) reference), ENT.

WARNING

When forcing input points with the set or RST sequence, be aware that the physical state of the input may be overridden. If the forced set or RST occurs in the user logic program before the input is checked in the same I/O scan, the set or RST state will take precedence and would cause an output to be turned on or off at the wrong time.

GEK-90842

SECTION 3

Data Operation Instructions for the Series One Plus Programmable Controller

Data Operations

The Series One Plus PC has, in addition to the basic ladder diagram functions, a group of instructions that include data moves, math functions, logical operations, conversion, and external fault diagnosis. These instructions provide the PC with the capability of performing various data operations. This group of instructions operate on multiple bits rather than one bit at a time. These instructions are not available with a Series One PC. For programs requiring many data operations, it is recommended that the Series One Plus 3.7K PC be used.

All of these instructions require that the data to be operated on be loaded (stored) into a 16-bit register called the accumulator. The data (numerical value) is processed in the CPU as BCD (Binary Coded Decimal). Each BCD value is represented by 4 corresponding bits in the accumulator. A BCD value can be any of the digits 0 through 9. When the specified operation is performed with the contents of the accumulator, the result of the operation is stored in the accumulator. This data can then be transferred to external outputs or stored internally to be used as needed. Additionally, data can be stored in registers (sixty-four 16-bit registers) and those registers referenced when programming the data operations. Each register can contain a 4-digit BCD number. Figure 5.27 is a block diagram showing how the data operations are performed.

Registers and the accumulator may also contain binary data, however arithmetic functions cannot be performed until the binary values are converted to BCD.

a40848

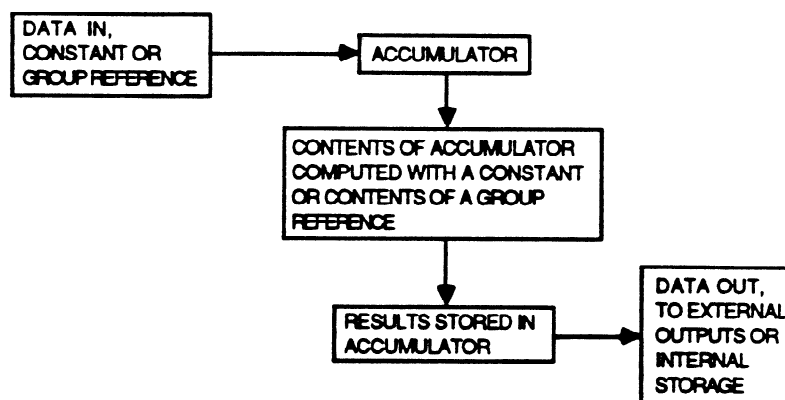

Figure 5-27. Data Operation Block Diagram

The contents of the accumulator do not change until new data is loaded into it with a D STR instruction or a computation takes place and the result is stored in the accumulator.

Using References for Data Operations

When entering an instruction for a data operation, the instruction is first specified, then the data. The data can be a constant value or a group reference that contains the data to be used.

Entering a Constant Value

a40849



Where XXXX is a 4-digit BCD number

When a constant (4-digit BCD number) is entered as the data value, the bits of the BCD numbers will be stored in the corresponding position in the accumulator, i.e., the least significant digit in the lower 4 bits of the accumulator, and the most significant digit in the upper 4 bits of the accumulator.

a40850

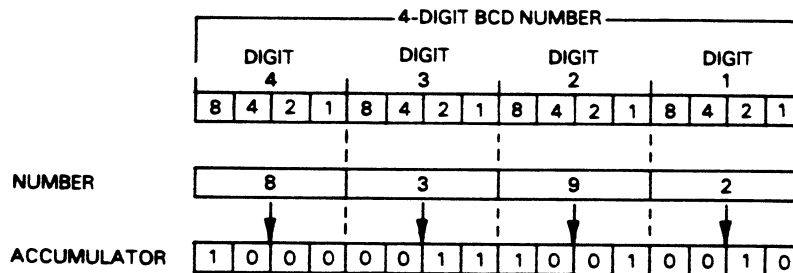

Entering a Group Reference



The I/O points, internal coils, and shift registers are treated as 8-bit registers when programming data operations. The references are then referred to as group references. By selecting the R key before a value, that value is operated on as an 8-bit or 16-bit register. For example, R 1 5 actually references 8 consecutive I/O points, 150 to 157. This is a convenient way of reading in data to the accumulator from input modules, or writing data from the accumulator to output modules for use as required by the user program. Certain instructions operate on 16 bits, in those cases the data will be read from or written to 16 consecutive references (one 16 circuit module or 2 adjacent 8 circuit modules). The group reference number for the references mentioned above can be either 1 or 2 digits.

GEK-90842

Data Register References

Data registers are referenced as 3-digit octal values with a valid range from 400 to 577. Although each individual register actually refers to one 8-bit byte, most registers are operated on as 16-bit words (2 consecutive registers). For example, if the key sequence R 4 0 2 is entered, the data operation uses data registers 402 and 403. If a 4-digit BCD value (for example 1234) were entered into the register, register 402 would contain the 2 least significant digits (34) and 403 the 2 most significant digits (12). A useful feature of the registers is that they can contain a value to be used as the preset for timers or counters. Unused T/C references 600-673 can be used as data registers. Each T/C reference operates on a 16-bit register.

Timer/Counter References

The timer/counter references are also 3-digit octal values. Each of the timer/counter references represent a 16-bit register. Valid range for the timer/counter references is 600 to 677. These registers contain the accumulated value of a timer or counter. It is important to note that the timer/counter accumulated value is not the same as the accumulator read to or written from when programming any of the data operations.

Example of Specifying a Group Reference

An example of specifying a group reference and how it relates to the accumulator is shown below. Example: Reference specified is 41.

a40851

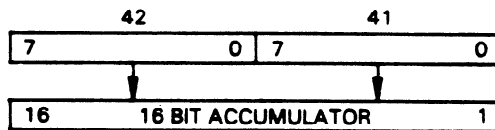

Contents of 41 and 42 (16 bits) are loaded into the accumulator

NOTE

Discrete bit 410 will be stored in the first position of the accumulator; discrete bit 427 will be stored in the last position (16) of the accumulator.

Programming the Data Operation Instructions

When a program is entered to perform any of the data operations, the first instruction must have at least one conditional contact entered immediately before it. To enter any of the data instructions, the F key must first be selected, then the Function number (F50, F63, F82, etc.) of the instruction. These numbers are assigned internally, by the CPU's operating system, to each of the data operation instructions and are listed in Table 5.8. After the F X X number has been entered, the program address will advance 1 step and the second word (data entry) should now be entered. The data entry is selected by entering SHF X X X X, for a constant value, or R X X X for a group reference.

Table 5-8. Data Operation Function Numbers

Instruction	Key Sequence	Instruction	Key Sequence
D•STR	F50	MULTIPLY	F73
D•STR1	F51	DIVIDE	F74
D•STR2	F52	D•AND	F75
D•STR3	F53	D•OR	F76
D•STR5	F55	SHIFT RIGHT	F80
D•OUT	F60	SHIFT LEFT	F81
D•OUT1	F61	DECODE	F82
D•OUT2	F62	ENCODE	F83
D•OUT3	F63	INV	F84
D•OUT5	F65	BIN (BCD TO BIN)	F85
CMPR	F70	BCD (BIB TO BCD)	F86
ADDITION	F71	EXTERNAL FAULT	
SUBTRACTION	F72	DIAGNOSIS	F20

The remainder of this chapter lists each of the data operation instructions and the information required for programming them. The format used to describe each of the instructions is as follows:

Mnemonic name for each instruction.

Function number that must be entered with the programmer (F50, F60, etc.)

Illustration of how each instruction operates in relation to the accumulator.

List of valid references (where required).

Keystrokes required to enter the instruction.

Program example to enhance the description of certain instructions.

Special Function Coils for Data Operations

A group of 6 special purpose internal coils in the Series One Plus are used as indicators of certain conditions that may occur when some of the data operations are performed. When these conditions occur, the applicable coil is turned on as a "Flag" or indicator that the condition has occurred. These coils can be included in your program as conditional contacts to turn on an output or perform some function to indicate that a Flag is on. These special purpose coils and their meanings are:

COIL REFERENCE	FLAG INDICATION
772	>, Greater Than
773	=, Equal to
774	<, Less Than
775	Carry or Borrow
776	Zero
777	Overflow

GEK-90842

D•STR (F50)

D•STR (Data Store) is a 2 word instruction which, when executed, loads the accumulator with a 4 digit BCD constant or the contents of a specified 2 byte reference.

NOTE

When loading I/O References or other data, be sure that it is in BCD Format. If not it should be converted before using the data for arithmetic functions.

a40852

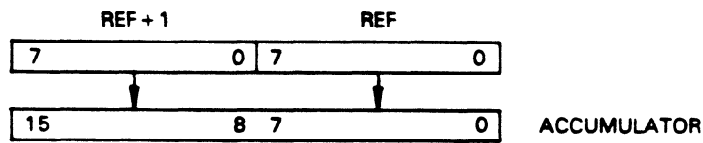

Valid Group References	
000 - 014	I/O Points
070 - 075	I/O Points
016 - 036	Internal Coils
040 - 056	Shift Register Coils
400 - 576	Data Registers (8-bit)
600 - 677	T/C Accumulated Value Registers (16-bit)
0000 - 9999	Constant (4-digit BCD)

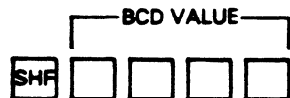
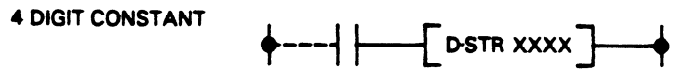
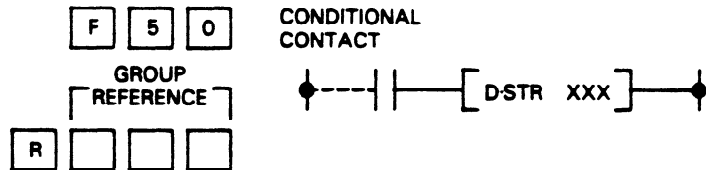

D•STR1 (F51)

This is a 2 word instruction which, when executed loads the lower 8 bits of the accumulator with the contents of a specified 1 byte reference. The upper 8 bits (8-15) will be zeros.

a40853

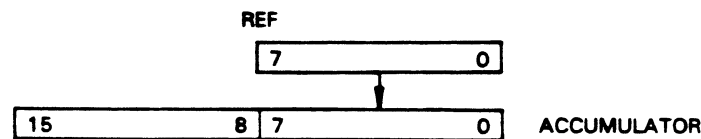

Valid Group References	
000 - 015	I/O Points
070 - 076	I/O Points
016 - 037	Internal Coils
040 - 057	Shift Register Coils
400 - 577	Data Registers (8-bit)

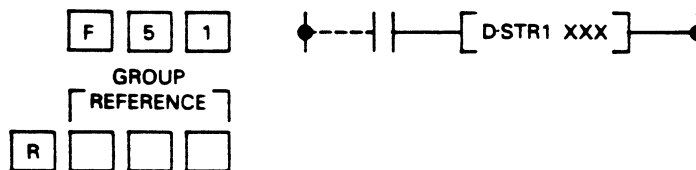

D•STR2 (F52)

This is a 2 word instruction which, when executed loads the lower 2 bits of the accumulator with the upper 4 bits of a specified 1 byte reference.

a40854

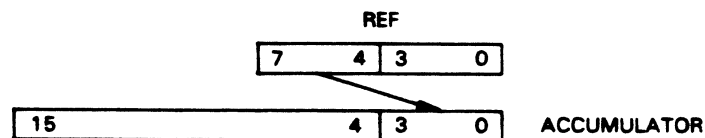

Valid Group References	
000 - 015	I/O Points
070 - 076	I/O Points
016 - 037	Internal Coils
040 - 057	Shift Register Coils
400 - 577	Data Registers (8-bit)

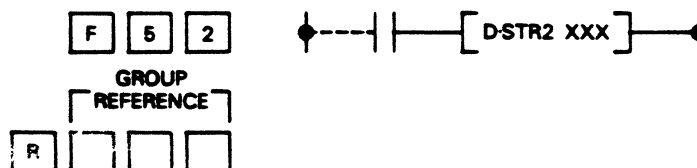

GEK-90842

D•STR3 (F53)

This is a 2 word instruction which, when executed loads the lower 4 bits of the accumulator with the lower 4 bits of a specified 1 byte reference.

a40855

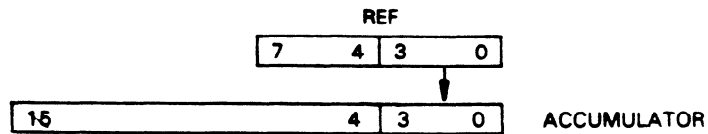

Valid Group References	
000 - 015	I/O Points
070 - 076	I/O Points
016 - 037	Internal Coils
040 - 057	Shift Register Coils
400 - 577	Data Registers (8-bit)

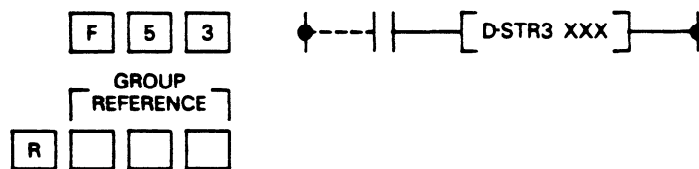

D•STR5 (F55)

This is a 2 word instruction which, when executed loads the accumulator with a BCD value from the 2 byte contents of a 16 circuit Input module.

a40856

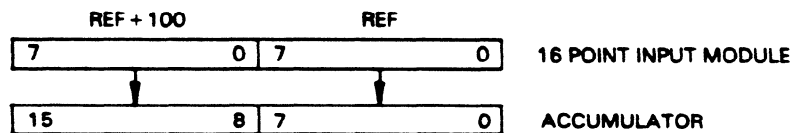

Valid Group Reference	
000 - 005	16 Point Input Module

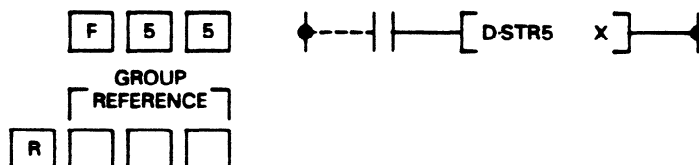

D•OUT (F60)

D•OUT (Data Out) is a 2 word instruction, which when executed transfers the contents of the accumulator (16 bits) to a specified 2 byte (group) reference (Output, Internal Relay, Shift Register coils, Data Registers or Timer/Counter accumulate value register).

a40857

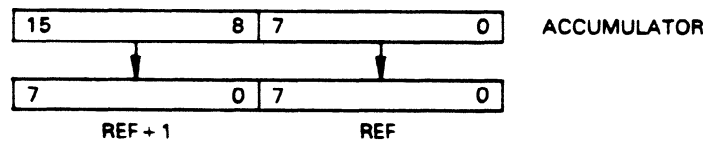

Valid Group References	
000 - 014	I/O Points
070 - 075	I/O Points
016 - 036	Internal Coils
040 - 056	Shift Register Coils
400 - 576	Data Registers (8-bit)
600 - 677	T/C Accumulated Value Registers (16-bit)

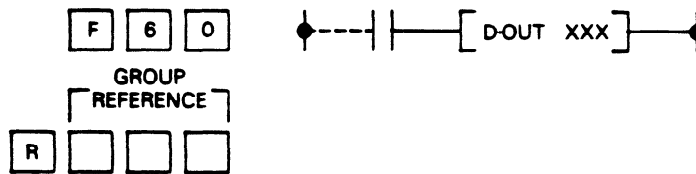

D•OUT1 (F61)

D•OUT1 is a 2 word instruction which, when executed will write the contents of the first 8 bits (0-7) of the accumulator to a specified reference.

a40858

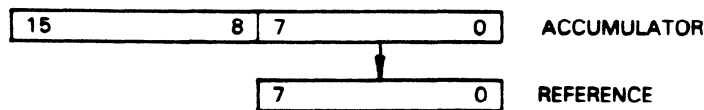

Valid Group References	
000 - 015	I/O Points
070 - 076	I/O Points
016 - 037	Internal Coils
040 - 057	Shift Register Coils
400 - 577	Data Registers (8-bit)

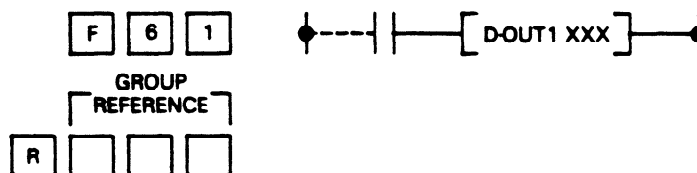

GEK-90842

D•OUT2 (F62)

D•OUT2 is a 2 word instruction which, when executed will write the contents of the lower (first) 4 bits of the accumulator to the upper 4 bits of a specified reference.

a40859

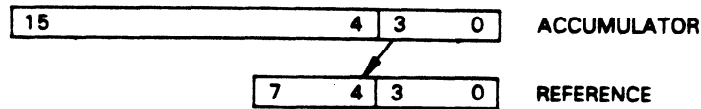

Valid Group References	
000 - 015	I/O Points
070 - 076	I/O Points
016 - 037	Internal Coils
040 - 057	Shift Register Coils
400 - 577	Data Registers (8-bit)

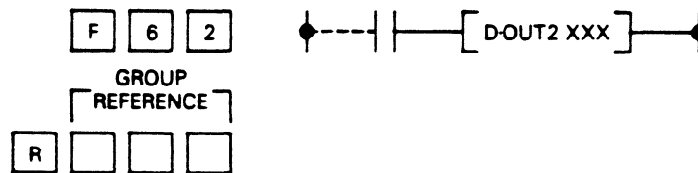

D•OUT3 (F63)

D•OUT3 is a 2 word instruction, which when executed will write the contents of the lower 4 bits of the accumulator to the lower 4 bits of a specified reference.

a40860

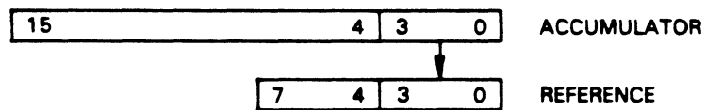

Valid Group References	
000 - 015	I/O Points
070 - 076	I/O Points
016 - 037	Internal Coils
040 - 057	Shift Register Coils
400 - 577	Data Registers (8-bit)

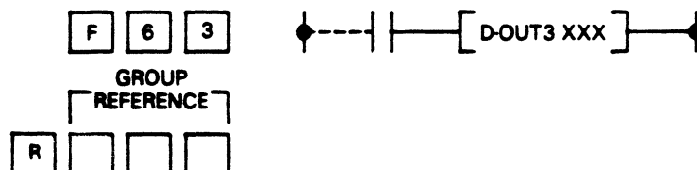

D•OUT5 (F65)

D•OUT5 is a 2 word instruction, which when executed will write the contents of the accumulator to a 2 byte reference which must be a 16 circuit Output module.

a40861

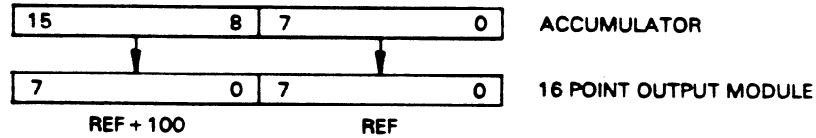

Valid Group Reference	
000 - 005	16 Point Output Module

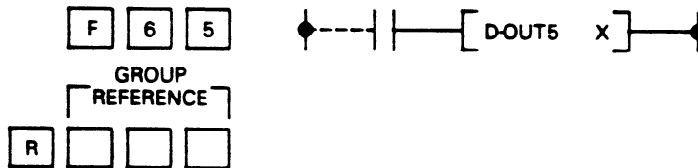

CMPR (F70)

The contents of a specified 2 group reference or a 4 digit BCD constant are compared to the contents of the accumulator. The result of the comparison will cause one of three special purpose internal coils to turn on, depending on whether the accumulator value is greater than (>), equal to (=) or less than (<) the value specified by the reference or constant.

a40862

Valid Group References	
000 - 014	I/O Points
070 - 075	I/O Points
016 - 036	Internal Coils
040 - 056	Shift Register Coils
500 - 576	Data Registers (8-bit)
600 - 677	T/C Accumulated Value Registers (16-bit)
0000 - 9999	Constant (4-digit BCD)

FLAGS		
>	=	<
772	773	774

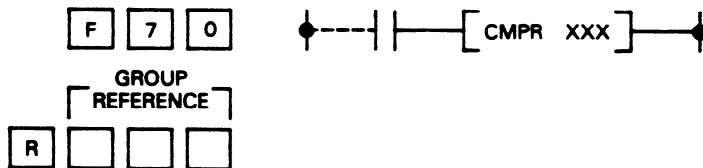

4 DIGIT CONSTANT

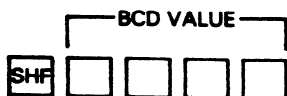

GEK-90842

• Compare sequence

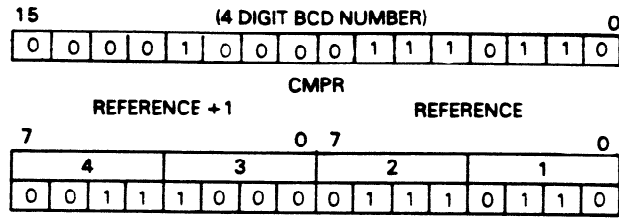

a40863

ACCUMULATOR CONTENTS

2 GROUP REFERENCE OR 4 DIGIT CONSTANT

- If Accumulator > Reference, then 772 turns ON.
- If Accumulator = Reference, then 773 turns ON.
- If Accumulator < Reference, then 774 turns ON.

• Programming example, Compare

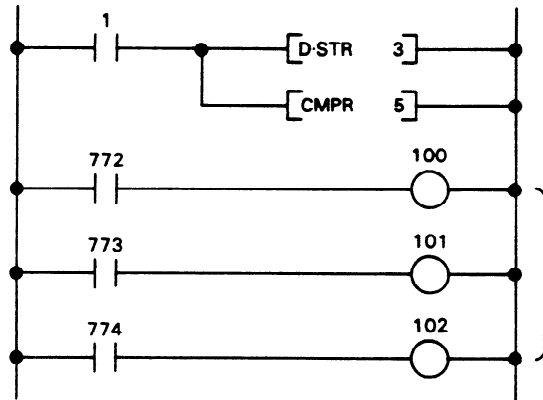

Addition (+), BCD 4 Digit (F71)

The contents of a 4 digit constant or a specified 2 group reference are added to the contents of the accumulator. The result of the addition is stored in the accumulator as a 4 digit BCD number. If the answer is >9999, the carry flag (Internal coil, 775) will turn on. If the answer is zero, the zero flag (776) will turn on. The flag coils can be used in a program as references for contacts to turn on an output connected to a light or other device to provide an indicator of the flag conditions.

a40864

Valid Group References	
000 - 014	I/O Points
070 - 075	I/O Points
016 - 036	Internal Coils
040 - 056	Shift Register Coils
400 - 576	Data Registers (8-bit)
600 - 677	T/C Accumulated Value Registers (16-bit)
0000 - 9999	Constant (4-digit BCD)

FLAGS	
CARRY OR BORROW	ZERO
775	776

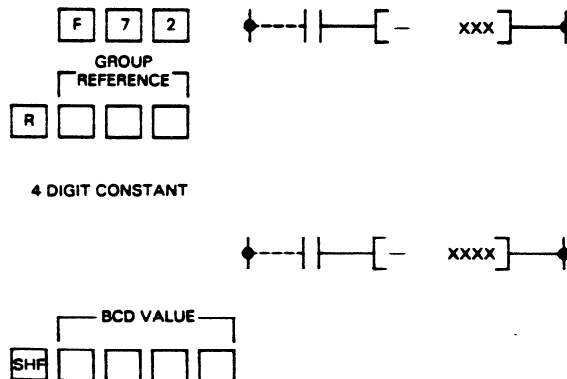

• Addition sequence

a40865

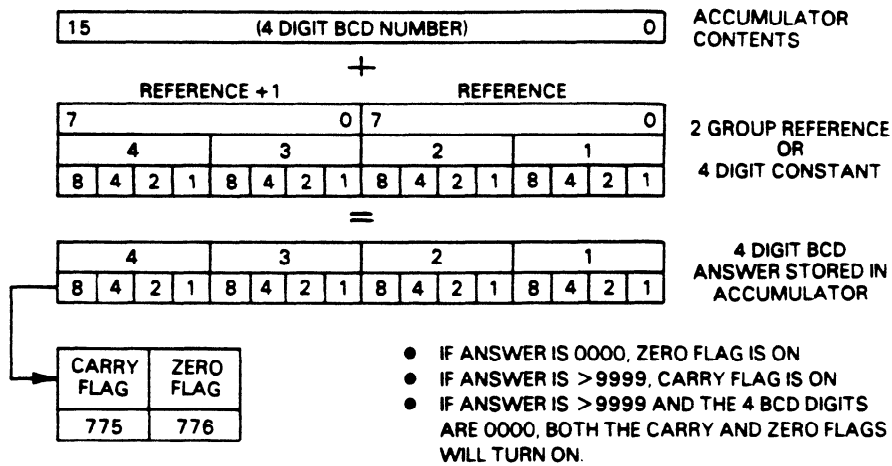

EXAMPLE:

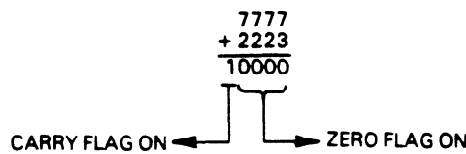

• Addition Programming Example

Example 1

4 BCD digits are loaded in accumulator from Inputs 0030-0047.

a40866

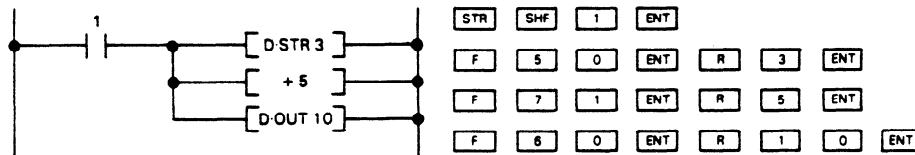

- The contents of the accumulator are added to data from Inputs 0050-0067.
- The answer is stored in the accumulator and also written to Outputs 0100 - 0117. If D OUT is specified as a Data Register, Internal coil, etc.; the answer would be stored at that location for further use in the program.

GEK-90842

Example 2

This example shows more than one constant value entered in the program. By closing the respective contact, a different number can be selected to be added to the contents of the accumulator.

a40867

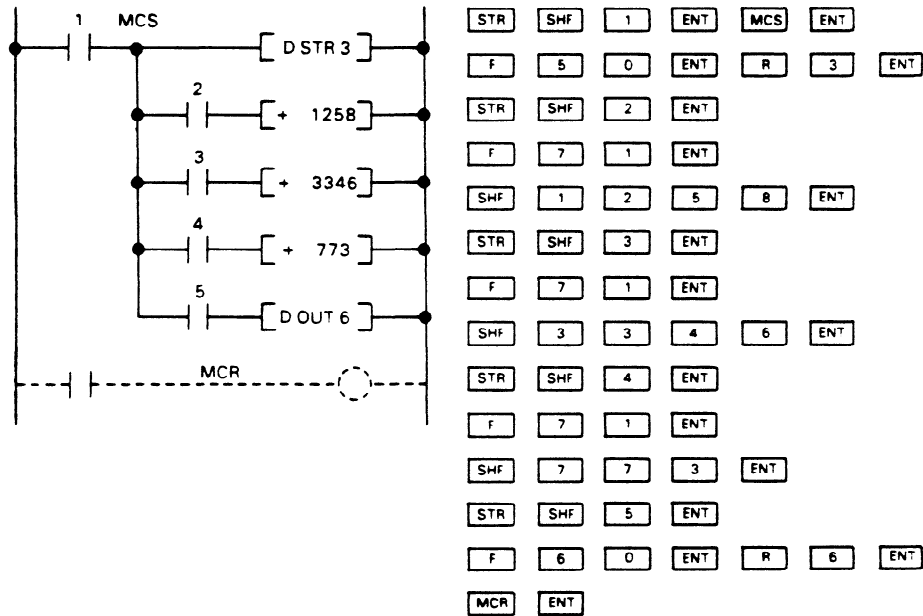

When I1 is closed, MCS is energized and does not control the logic following it. The number selected by closing one of the contacts, I2, I3, or I4 is added to the contents of the accumulator (read from Inputs 0030-0047). When I5 is closed, the answer will be written to Outputs 0060-0077.

Subtraction (-), BCD 4 Digit (F72)

The contents of a specified 2 group reference or a 4 digit BCD constant value are subtracted from the contents (BCD) of the accumulator. If the answer after the subtraction is positive, it is written directly to the accumulator. If the answer is negative, the Borrow Flag (775) turns ON, the absolute value is subtracted from 10000 and the resulting value is written to the accumulator. If the answer after subtraction is zero, the Zero flag (776) turns ON.

a40868

Valid Group References	
000 - 014	I/O Points
070 - 075	I/O Points
016 - 036	Internal Coils
040 - 056	Shift Register Coils
400 - 576	Data Registers (8-bit)
600 - 677	T/C Accumulated Value Registers (16-bit)
0000 - 9999	Constant (4-digit BCD)

FLAGS	
CARRY	ZERO
775	776

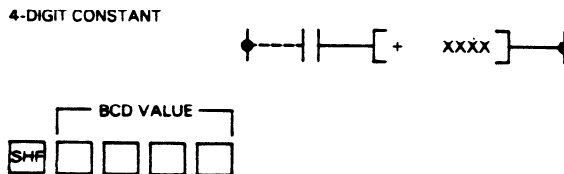
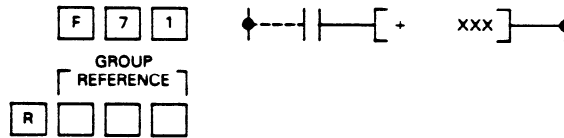

GEK-90842

• Subtraction sequence

a40869

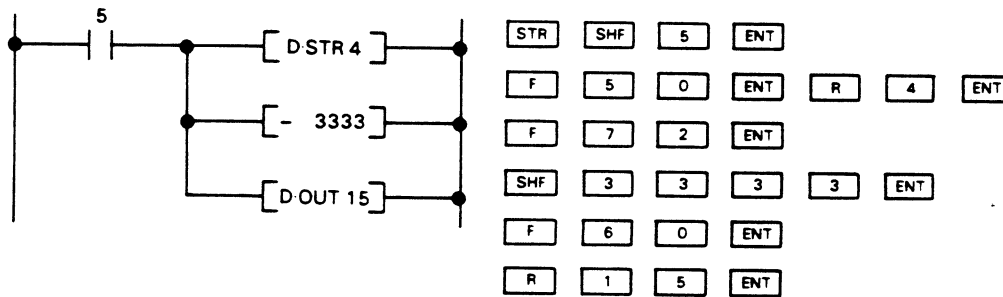
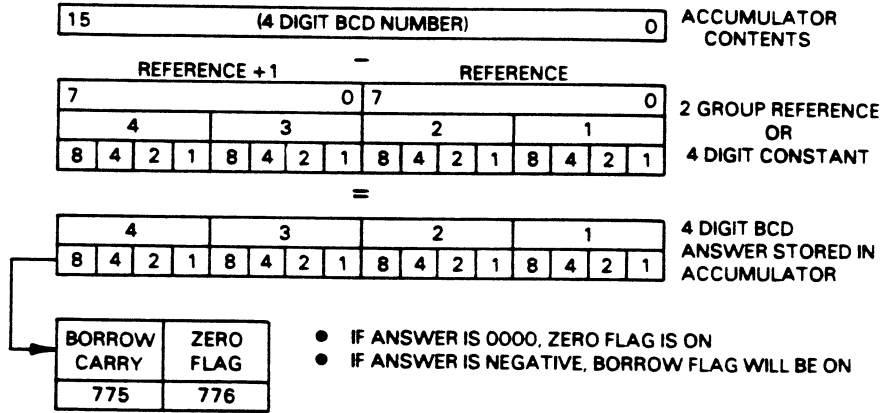

• Subtraction programming example

- Data is entered into the accumulator from Inputs 0040 - 0057.
- A constant value (3333) is subtracted from the contents of the accumulator.
- The answer is stored in the accumulator and is written to outputs 0150 - 0167.

Multiplication (X), BCD 4 Digit (F73)

The contents of the accumulator are multiplied by the contents of a specified 2 group reference or a 4 digit BCD constant. The answer can be from 1 to 8 digits. The lower 4 digits of the answer are stored in the accumulator and digits 5-8 are stored in data registers 576 and 577, which are the auxiliary accumulator. If the answer is zero, the Zero flag (776) will turn ON.

a40870

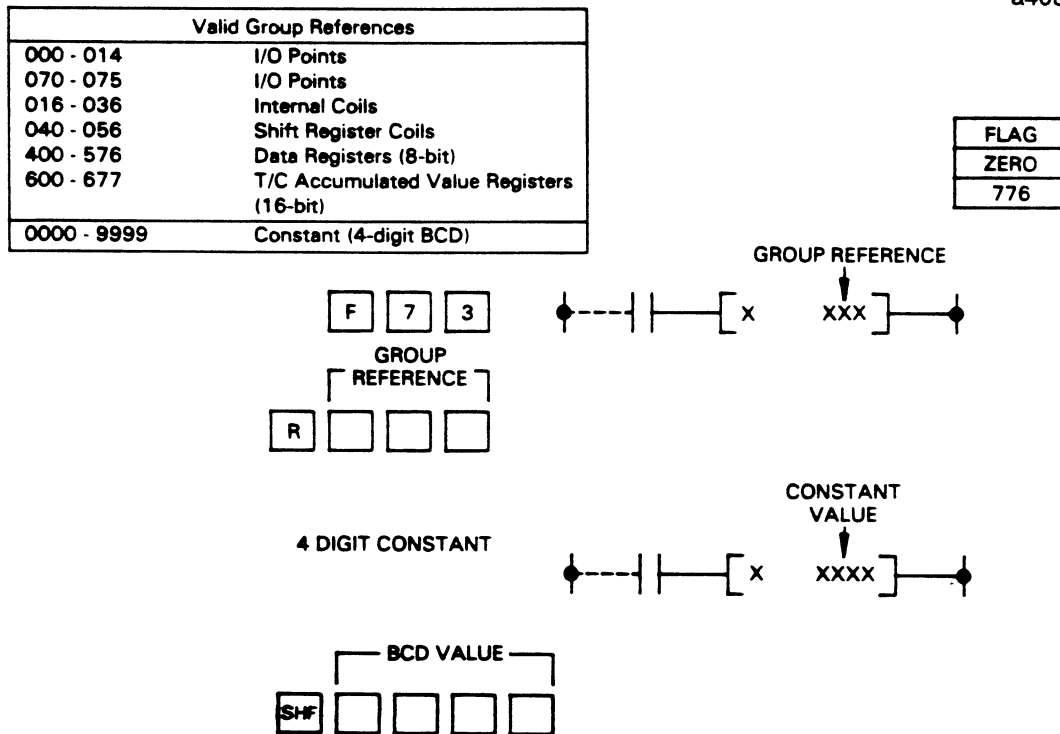

• **Multiplication sequence**

a40871

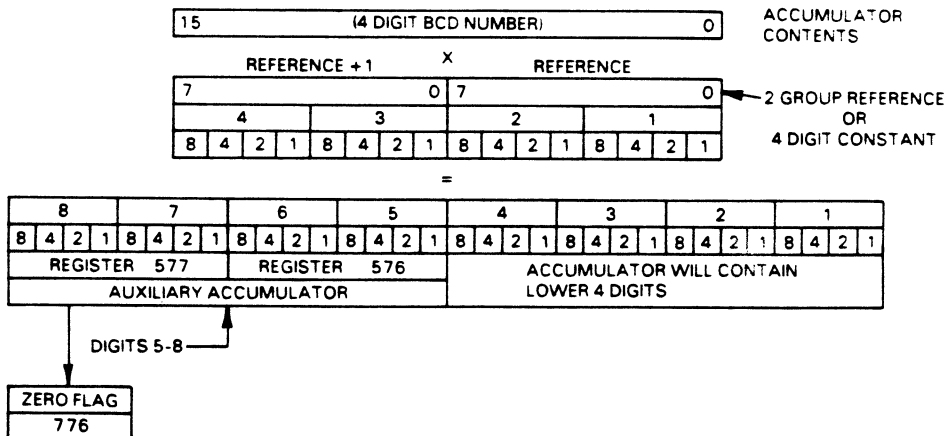

- The lower 4 digits (1, 2, 3, 4) of the answer will be stored in the accumulator. The upper 4 digits (5, 6, 7, 8) will be stored in the auxiliary accumulator (Data Registers 576 and 577).
- If the answer is 00000000, the Zero flag (776) is ON.

GEK-90842

• Multiplication programming example

Multiplying 4 digits by 4 digits with an answer containing 8 digits.

a40872

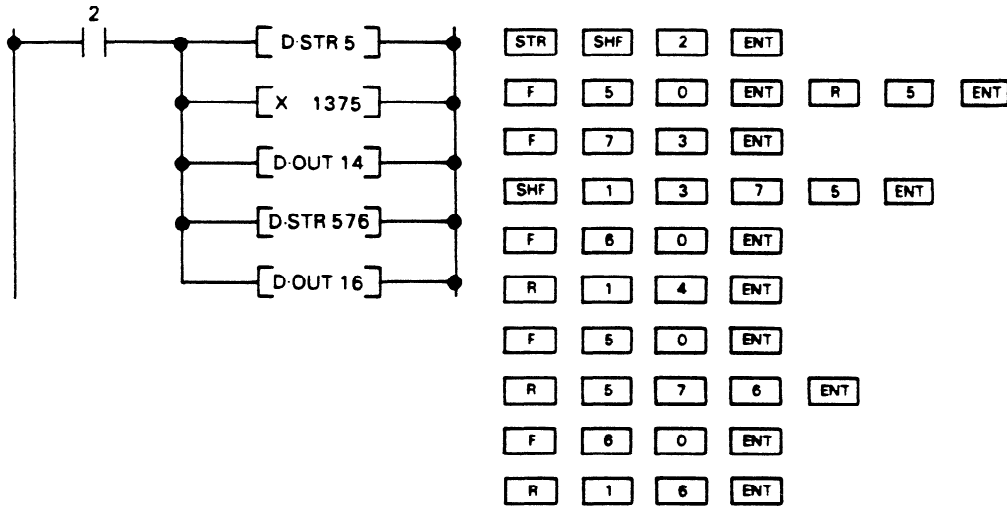

- A 4 digit BCD value is entered into the accumulator from Inputs 0050-0067.
- A constant value (1375) is entered as the multiplier.
- Assume that the answer is an 8 digit BCD number. The lower 4 digits are stored in the accumulator and transferred to Outputs 0140-0157. The upper 4 digits are stored in the auxiliary accumulator (Data Registers 576, 577) and transferred to Outputs 0160-0177.

Division (÷), BCD 4 Digit (F74)

The contents of the accumulator are divided by the contents of a specified 2 group reference or a 4 digit BCD constant. The 4 digits of the quotient are stored in the accumulator and the 4 digits of the remainder are stored in the auxiliary accumulator (Data Registers 576, 577). If either the dividend or divisor are zero, the Zero flag (776) will turn ON. If the divisor is zero, the Overflow flag (777) will also turn ON.

a40873

Valid Group References	
000 - 014	I/O Points
070 - 075	I/O Points
016 - 036	Internal Coils
040 - 056	Shift Register Coils
400 - 576	Data Registers (8-bit)
600 - 677	T/C Accumulated Value Registers
0000 - 9999	Constant (4-digit BCD)

FLAGS	
ZERO	OVERFLOW
776	777

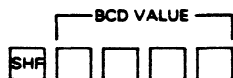
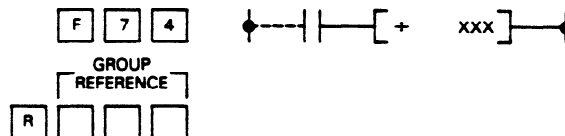

• Division sequence

a40874

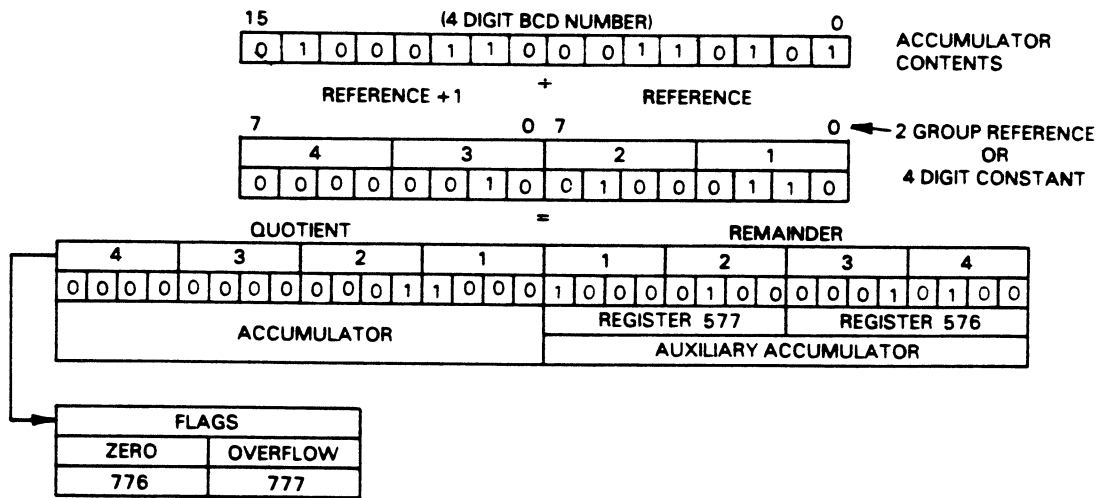

• The quotient (0 - 4 digits) will be stored in the accumulator as shown. the remainder (0 - 4 digits) will be stored in the auxiliary accumulator (Data Registers 577, 576) as shown.

• Division programming example

Division of a 4 digit number by another 4 digit number showing how the quotient and remainder can be written to Outputs.

a40875

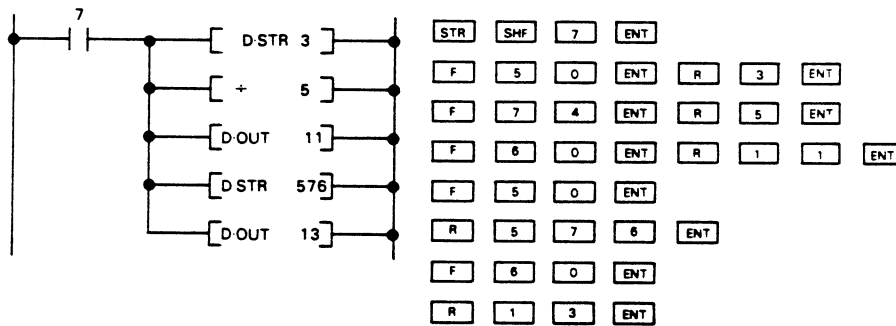

- A 4 digit number is entered into the accumulator from Inputs 0030 - 0047.
- That number is divided by a number specified by Inputs 0050 - 0067.
- The 4 digits of the quotient are stored in the accumulator and are also written to Outputs 0110 - 0127.
- The 4 digits of the remainder are stored in the auxiliary accumulator (Data Registers 577, 576) and are written to Outputs 0130 - 0147.

GEK-90842

D•AND (DATA AND) (F75)

The contents of the accumulator are logically bit AND-ed with the contents of a specified 2 group reference or a 4 digit BCD constant. The result is stored in the accumulator. If the answer is 0000, the Zero flag (776) will turn ON.

a40876

Valid Group References	
000 - 014	I/O Points
070 - 075	I/O Points
016 - 036	Internal Coils
040 - 056	Shift Register Coils
400 - 576	Data Registers (8-bit)
600 - 677	T/C Accumulated Value Registers (16-bit)
0000 - 9999	Constant (4-digit BCD)

FLAG
ZERO
776

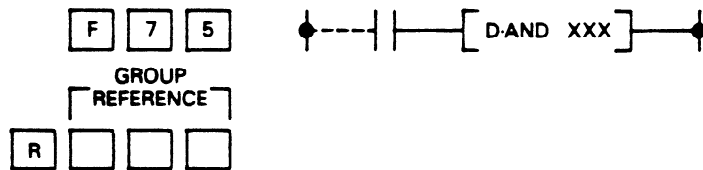

4 DIGIT CONSTANT

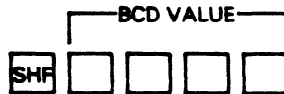
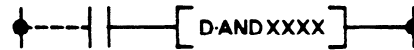

D•AND Sequence

a40877

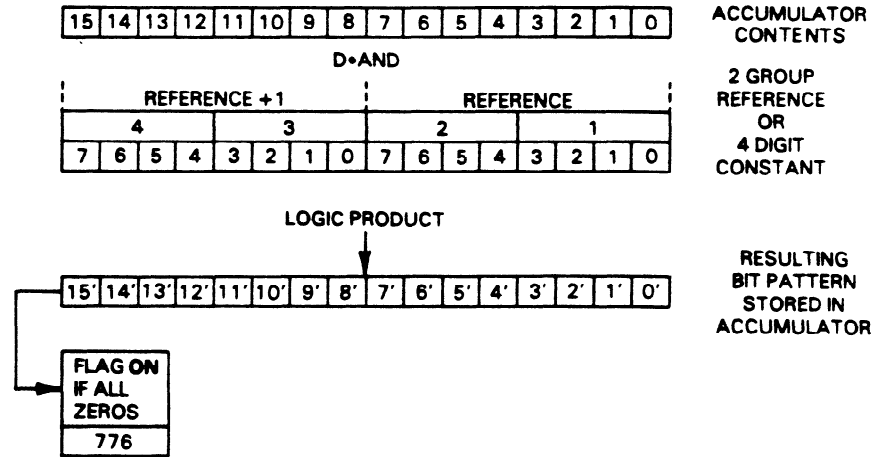

- Truth table for D•AND operation.
 A = Accumulator contents
 D = Contents of reference or constant

A	D	RESULT
0	0	0
0	1	0
1	0	0
1	1	1

• Programming example, D•AND

a40878

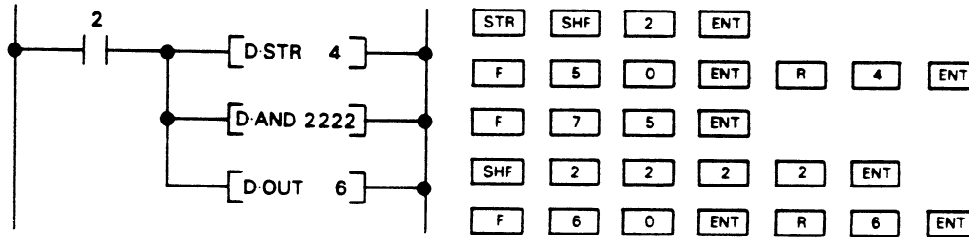

- Assume the data entered into the accumulator from Inputs 0040 - 0057 = 1234
- Is logically AND-ed with 2222
- The resulting answer stored in the accumulator would be 0220
- 0220 is written to Outputs 0060 - 0077
- Accumulator and reference contents for above operation are shown below

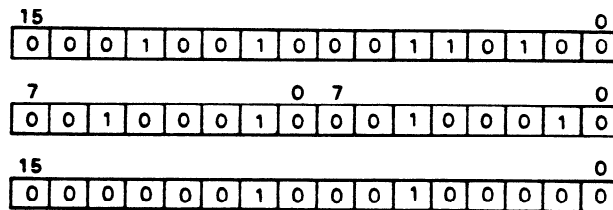

GEK-90842

D•OR (DATA OR) (F76)

The contents of the accumulator are logically bit OR-ed with the contents of a specified 2 group reference or a 4 digit BCD constant. The result is stored in the accumulator. If the answer is 0000, the Zero flag (776) will turn ON.

Valid Group References	
000 - 014	I/O Points
070 - 075	I/O Points
016 - 036	Internal Coils
040 - 056	Shift Register Coils
400 - 576	Data Registers (8-bit)
600 - 677	T/C Accumulated Value Registers (16-bit)
0000 - 9999	Constant (4-digit BCD)

a40879

FLAG
ZERO
776

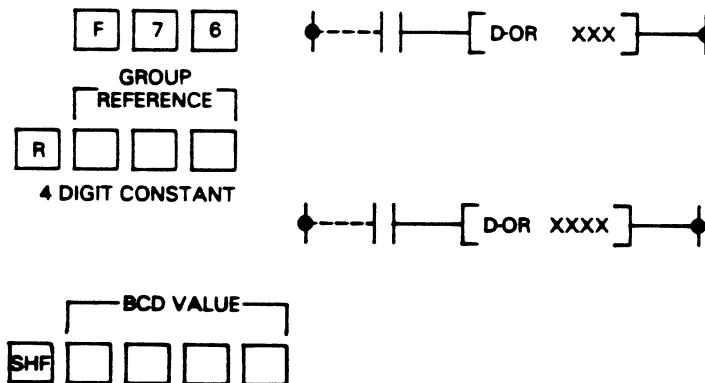

D•OR Sequence

a40880

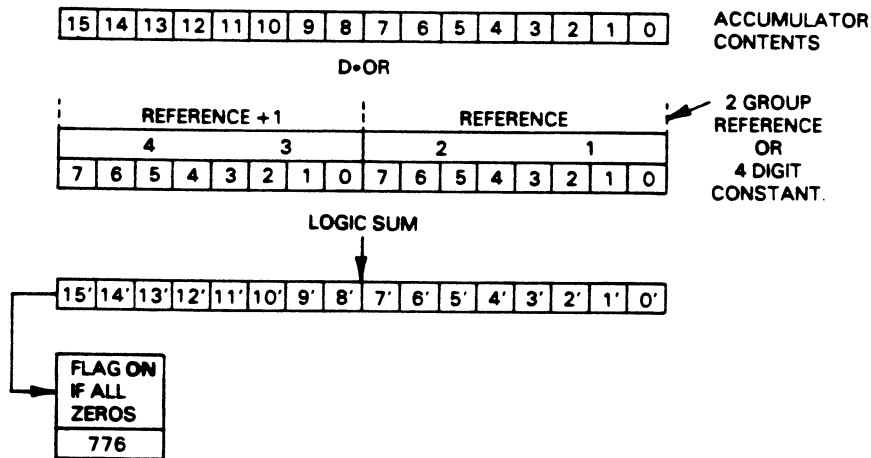

- Truth table for D•OR operation.
 A = Accumulator contents
 D = Contents of reference or constant

A	D	RESULT
0	0	0
0	1	1
1	0	1
1	1	1

- Programming example, D•OR

a40881

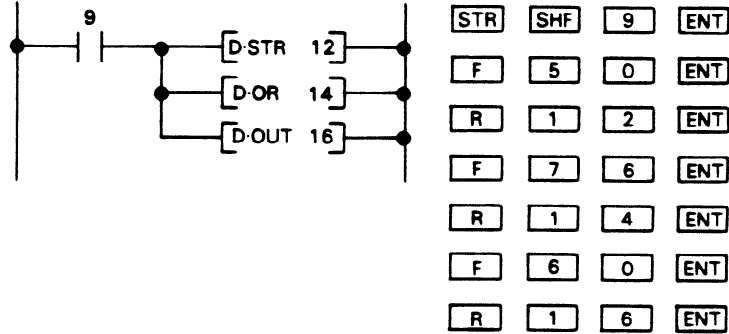

- Assume data entered into the accumulator from Inputs 0120 - 0137 = 3210
- Is logically OR-ed with data from Inputs 0140 - 0157 = 7531
- The resulting answer stored in the accumulator will be 7731
- 7731 is written to Outputs 0160 - 0177
- Accumulator and reference contents for above operation are shown below

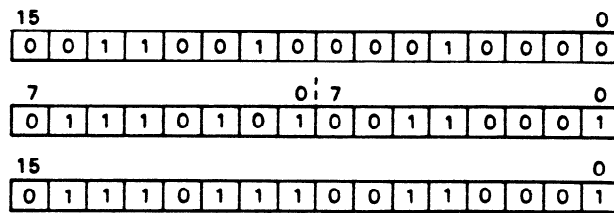

GEK-90842

Shift Right (F80)

The contents of the accumulator are shifted to the right by the number of shifts (bits) specified by the instruction. The number of bits shifted can be from 1 to 15. The bit positions of bits shifted from the left are filled with zeros. If a '1' is shifted out of the accumulator as a result of the shift, the Carry flag (775) will turn on. If after the shift, the accumulator contains only zeros, the Zero flag (776) will turn on.

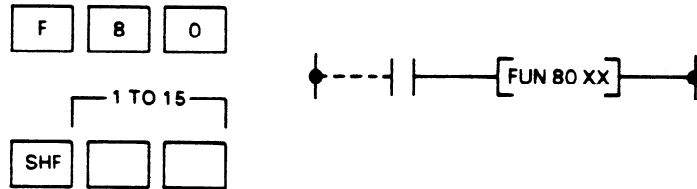

a40882

• FUN 80, Shift Right sequence (6 shifts in example)

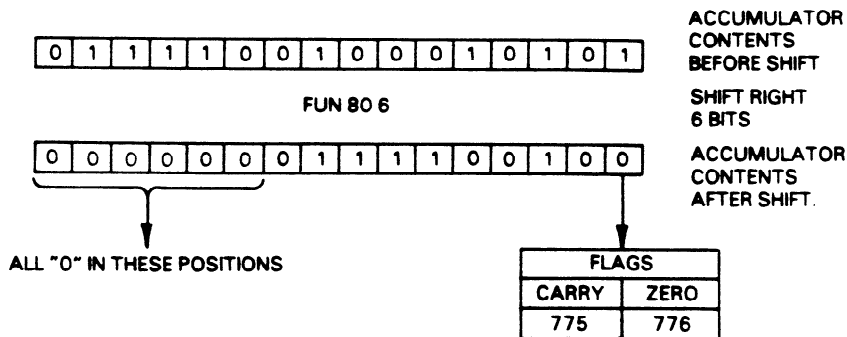

Shift Left (F81)

The contents of the accumulator are shifted to the left by the number of shifts (bits) specified by the instruction. The number of bits shifted can be from 1 to 15. The bit positions of bits shifted from the right are filled with zeros. If a '1' is shifted out of the accumulator as a result of the shift, the Carry flag (775) will turn on. If after the shift, the accumulator contains only zeros, the Zero flag (776) will turn on.

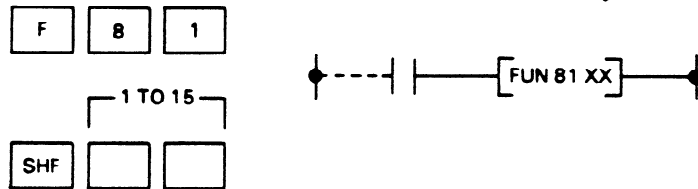

a40883

• FUN 81, Shift left sequence (4 shifts in example)

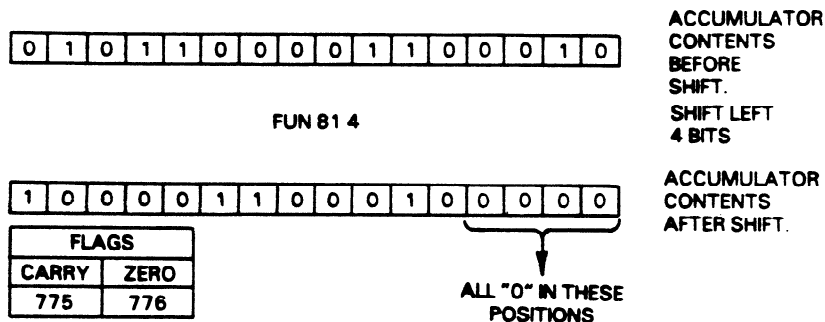

• Programming example using FUN 80 and FUN 81

This example shows a technique that can be used for deleting unnecessary data after it has been entered into the accumulator. In the example the fourth BCD digit will be deleted.

a40884

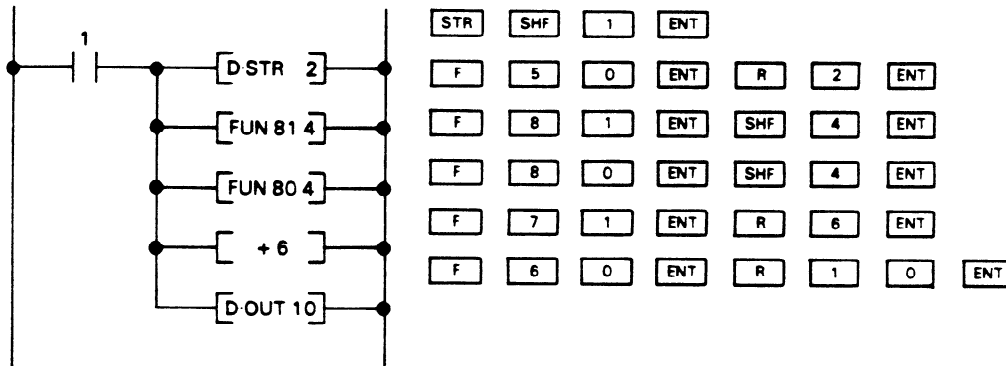

• Data entered into accumulator from Inputs 0020 - 0037.

•

• Shifted left, 4 bits.

•

• Shifted right, 4 bits.

•

• The fourth digit (5) has been deleted.

•

• The remaining value is added to the contents of Inputs 0060 - 0077. The result is stored in the accumulator and written to Outputs 0100 - 0117.

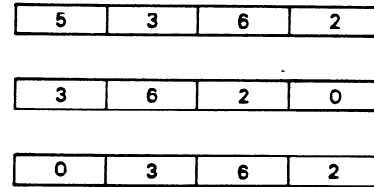

GEK-90842

Decode (F82)

The lower 4 bits (least significant) of the accumulator are decoded to a decimal number from 0 to 15. A "1" is placed in the bit position in the accumulator that corresponds to the decoded decimal number. The upper 12 bits of the accumulator are disregarded for this operation.

a40885



• FUN 82 Decode sequence

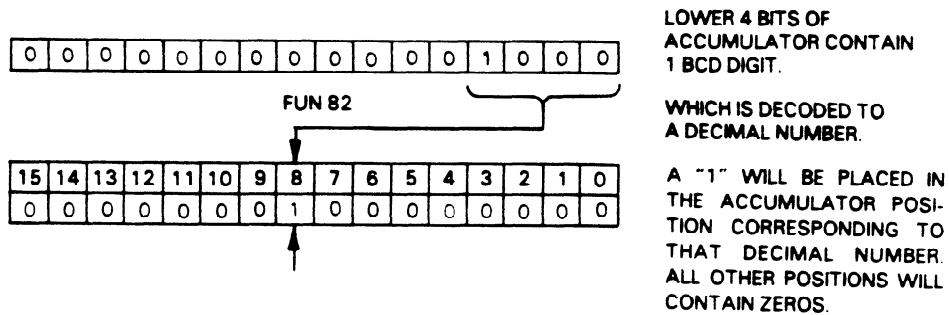

• If the BCD digit to be decoded is an 8, A "1" will be placed in the accumulator at that position as shown.

• Programming example, FUN 82

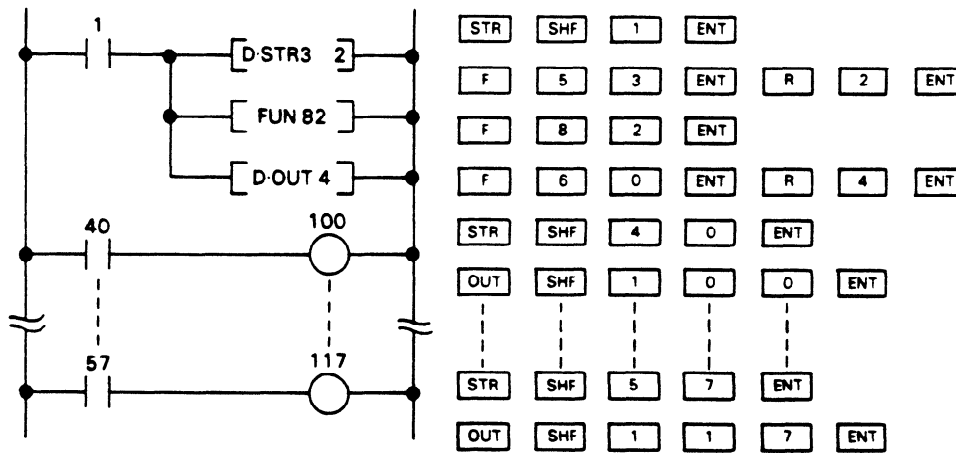

a40886

- A BCD digit (for example: 6) is loaded into the accumulator (lower 4 bits) from the lower 4 bits of the reference, Inputs 20, 21, 22, and 23. The bit pattern loaded in the accumulator would be 0 1 1 0.
- The BCD digit is decoded to a decimal number between 0 - 15 (in this example 6).
- That number is stored in the corresponding bit position in the accumulator.
- Outputs 0040 to 0057 correspond to the 16 bits of the accumulator. One of the outputs will be enabled when the accumulator position has a "1" placed in it. When the contact corresponding to the output reference is closed, a coil 100 - 117 will turn on.

Encode (F83)

A bit in a position in the accumulator is encoded to a 4-bit code representing the position number (0-15) in the accumulator. The resulting 4-bit code is placed in the lower four bits of the accumulator.

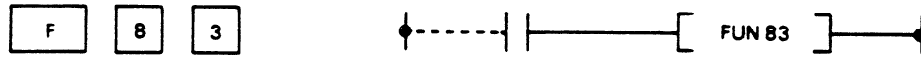

a40887

• FUN 83 Encode sequence (example)

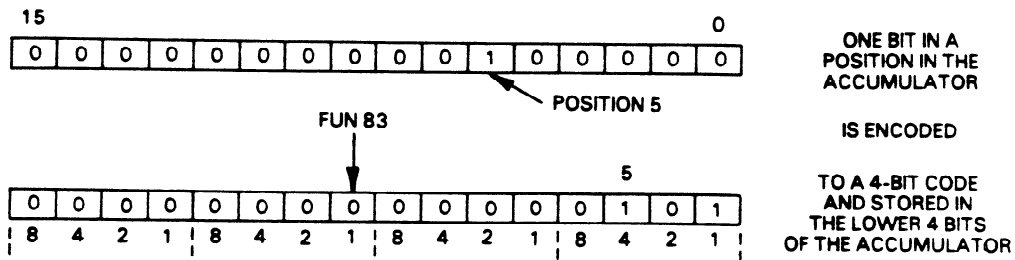

- The upper 12 bits of the accumulator will contain zeros after the FUN 83 has been executed.

INV (F84)

The 16 bits stored in the accumulator are logically inverted; i.e., 1 to 0 and 0 to 1.

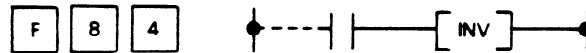

a40888

• Invert sequence

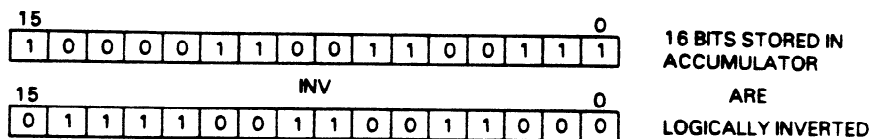

• Programming example, INV

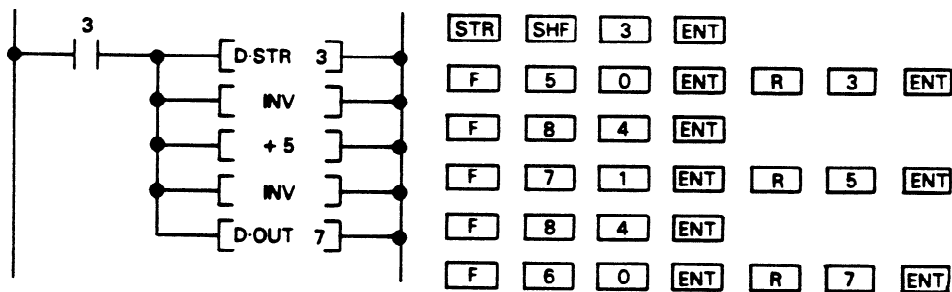

- Data entered into the accumulator from Inputs 0030 - 0047 is inverted.
- The inverted data is added to data from Inputs 0050 - 0067. The answer is stored in the accumulator, then inverted again.
- Data is written to Outputs 0070 - 0107

GEK-90842

BIN (BCD to Binary) (F85)

The BCD value stored in the accumulator is converted to a binary code corresponding to that value.

a40889

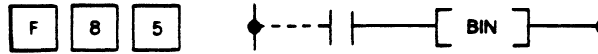

- Binary conversion sequence

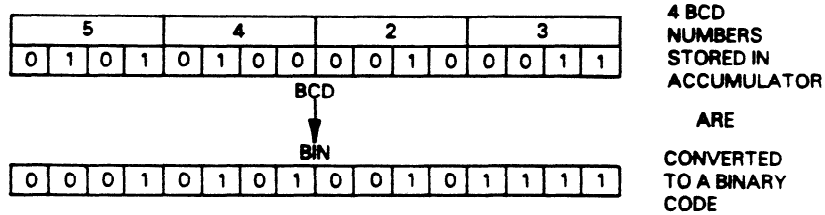

- Programming example, BIN

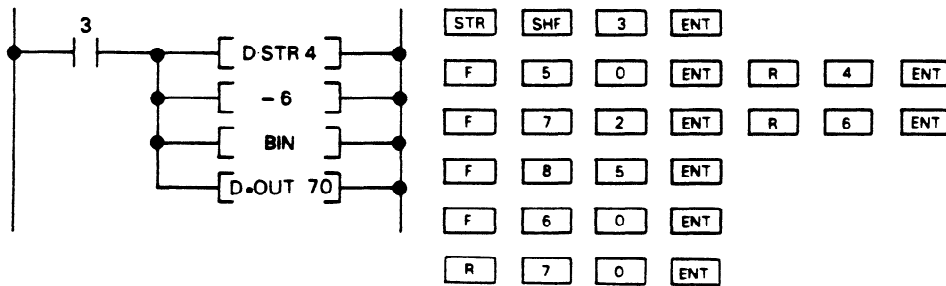

- Data is stored in the accumulator from Inputs 0040 - 0057.
- Data entered from Inputs 0060 - 0077 is subtracted from the value in the accumulator.
- The resulting answer is stored in the accumulator, where it is converted to a binary code.
- The binary code is written to Outputs 0700 - 0717.

BCD (Binary to BCD) (F86)

A binary code stored in the accumulator is converted to a 4 digit BCD value. If the resulting BCD value is >9999, the overflow flag (777) will turn on. The flag coil can be used to turn on an output device as an indication of the overflow.

a40890

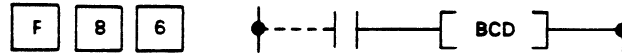

• BCD conversion sequence

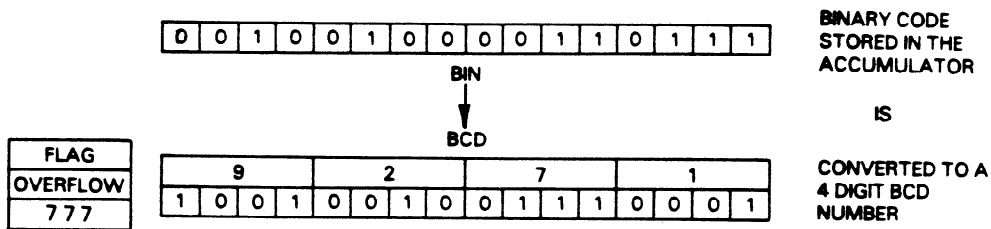

• Programming example, BCD

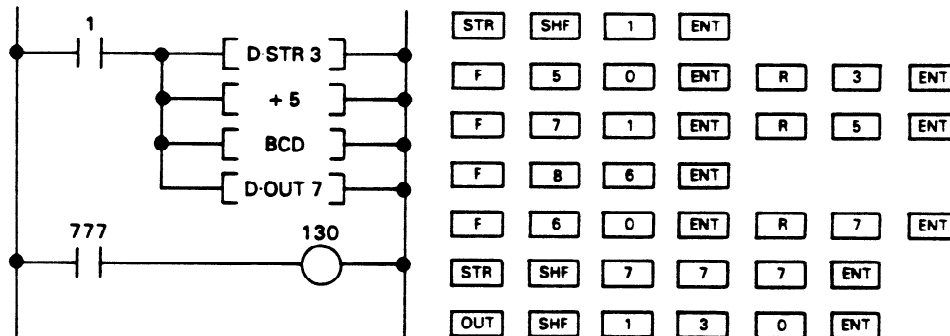

- Data is stored in the accumulator from Inputs 0030 - 0047.
- Data from Inputs 0050 - 0067 is added to the value in the accumulator.
- The resulting answer is stored in the accumulator, where it is converted to a 4 digit BCD number.
- The BCD number is written to Outputs 0070 - 0107.
- If an overflow occurs, the overflow Flag 777 will turn on Output 130.

GEK-90842

External Fault Diagnosis (F20)

This instruction provides a method of monitoring external devices for unwanted conditions such as switches that should not be on at the same time. When the instruction is programmed, a 4 digit BCD number is specified as a fault indication number. If the unwanted condition occurs, the 4 digit number will be displayed on the programmer data display. The 4 digit number can be a constant value or read from a group reference.

a40891

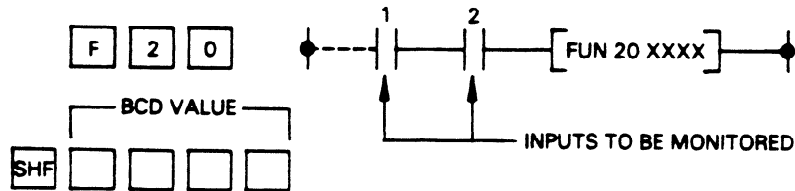

More than one FUN 20 instruction can be used in a program for detection of multiple fault conditions. Each condition to be monitored is assigned a different 4 digit number. If multiple faults occur simultaneously, the number displayed will be the one assigned by the last FUN 20 in the program. Data Registers 574 and 575 will contain the fault indicator number. When a fault number is displayed on the programmer, the fault number can be cleared from the display by depressing the CLR key. However, it is recommended that the actual fault be fixed before clearing the display.

• Programming example, FUN 20

a40892

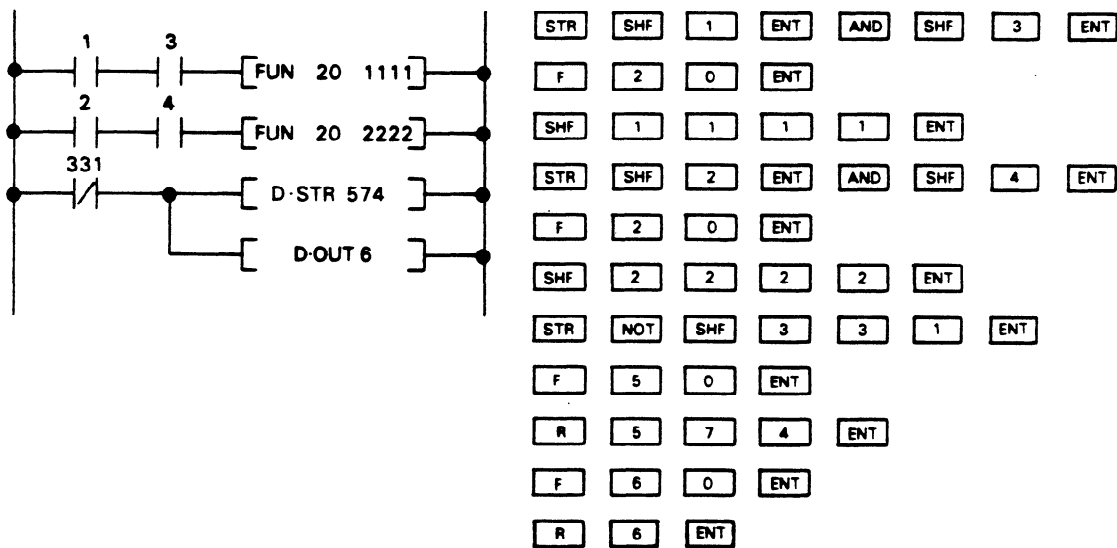

- If devices connected to I1 and I3 are made at the same time, FUN 20 will be active, 1111 will be displayed on the data display on the programmer.
- If devices connected to I2 and I4 are made at the same time the data display will display 2222.
- The indicator number will be stored in 574 and 575 and that number will be written to Outputs 0060-0077.
- Fault indicator number display



- The physical fault should be cleared. Then clear the programmer display with the CLR key.

GEK-90842

I/O System Introduction

The Input/Output (I/O) of the Series One and Series One Plus PCs is provided on modules (figure 6-1) each typically with 4, 8, or 16 input circuits or 4, 8, or 16 output circuits. These modules are inserted into slots in the racks. Up to 4 modules in a 5-slot rack or 9 modules in a 10-slot rack of any I/O mix can be placed in the first rack with the CPU. Up to 5 modules in a 5-slot rack or 10 modules in a 10-slot rack, again of any I/O mix can be placed in each of the expansion racks.

The I/O references are assigned to each slot by its physical position (see table 5-5). The only address switches that need to be set are associated with the racks. In the 5-slot rack, a 2 position switch must be set which specifies whether the rack is a CPU or expansion rack. Series One Plus 10-slot racks have 2 bridge connectors, on the backplane, which must be set to specify whether the rack is a CPU or expansion rack and the I/O addressing configuration for slot 10 of the CPU rack and all slots in the expansion rack. Installation and wiring of these modules is discussed in Chapter 3, Installation. This chapter will discuss the capabilities of these I/O modules, to allow the user to properly design wiring diagrams and apply these modules.

Field Wiring to I/O Modules

Each of the 8 circuit I/O modules, has a terminal block attached to it with 10 screw terminals. The 16 point I/O modules, with screw terminals, have a removable socket type terminal board on the front of the module. The terminal board can be easily removed, which allows modules to be readily removed or changed without removing the field wiring to the module. Each of these terminals are capable of accommodating one AWG No. 12 or two AWG No. 14 stranded wires. A clear plastic cover snaps over the terminals as a safety precaution. An insert is included with the covers to record circuit identification.

Some of the 16 point I/O modules are connected to field wiring through a connector mounted on the faceplate. A description of these modules is on the following page.

The rest of this chapter provides specifications, wiring diagrams, typical schematics, and sample reference numbers for each module type. The typical schematics are to provide details for interfacing and not for maintenance or repair of these modules.

The sample reference numbers should be adjusted by the user to the actual slot in which the modules will be installed. Every slot is provided with eight references. Those modules that provide eight circuits still consume 8 I/O references. When 4 circuit modules are used, the four references not used to interface to "real world" I/O, are available for use as internal references for the user's logic program. A 16 circuit I/O module uses 2 groups of 8 I/O references.

GEK-90842

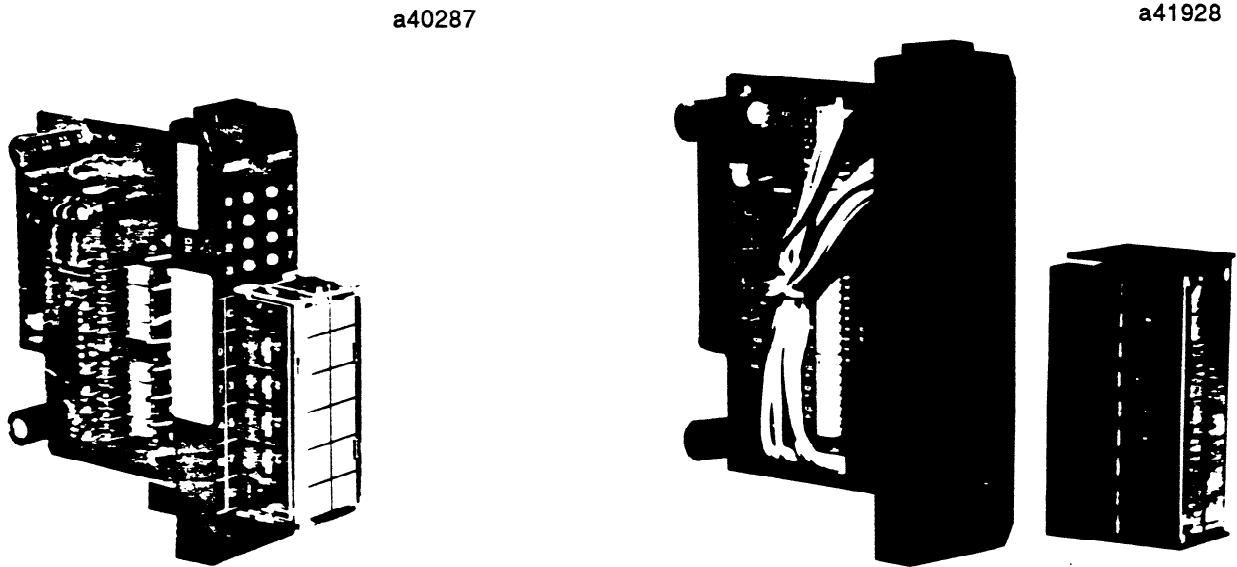

Figure 6-1. A. Typical I/O Module B. High Density Module With Removable Connector

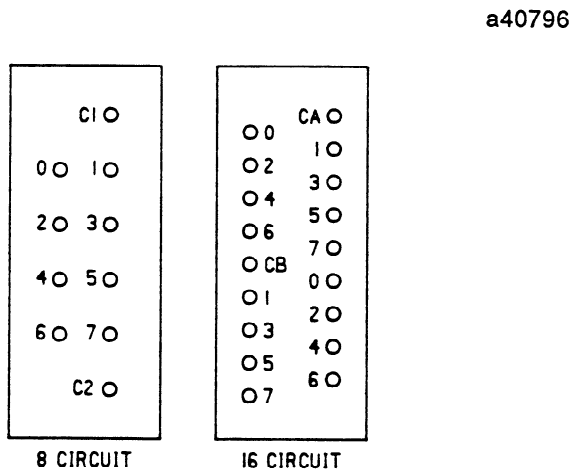

Figure 6-2. Typical I/O Terminal Configuration

16 Circuit I/O Modules with Connectors

Some of the I/O modules providing 16 input or 16 output circuits have a 24-pin connector on the faceplate. These modules are connected to user supplied input devices or user supplied loads through an I/O Interface cable which is 10 feet (3m) in length (Catalog Number IC610CBL105). One end of this cable has a 24-pin female connector which mates with a 24-pin male connector mounted on the faceplate of the I/O module. The wires on the opposite end of the cable are stripped and tinned for connection to user devices. Each of the wires is color coded for easy identification. Figure 6-3 is a wiring list for the I/O Interface cable.

a42155

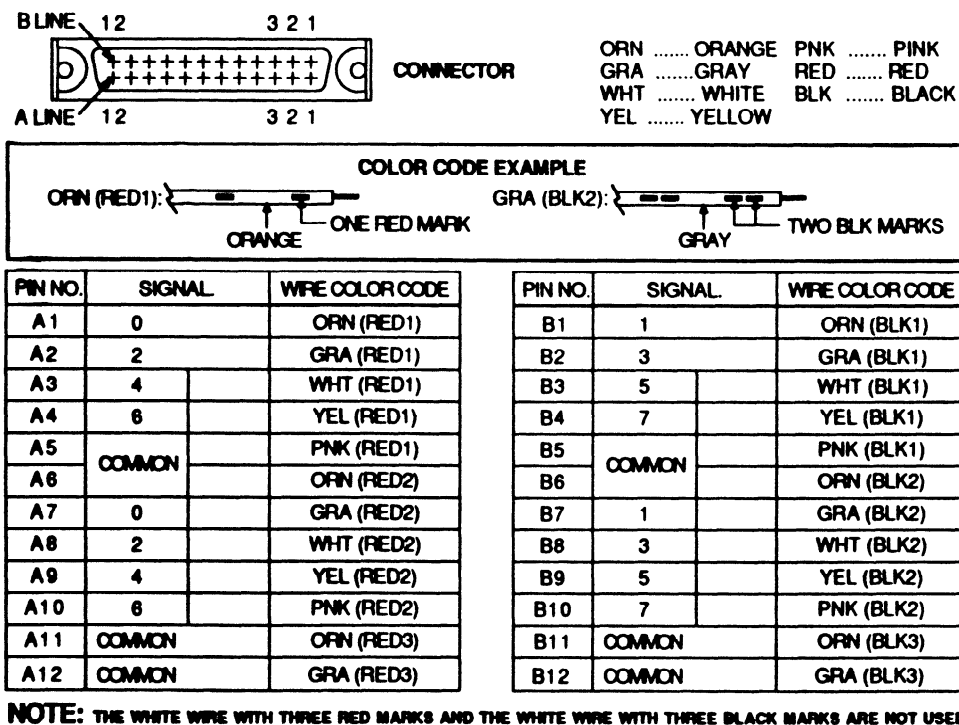

Figure 6-3. I/O Interface Cable Wiring List

I/O References for 16 Circuit Modules

When using a 16 circuit I/O module, addresses are borrowed from future slots. The illustration in figure 6-4 is used as an example of this concept. For instance, if a 16 circuit module is installed in slot 02, the I/O references for that module will be 020-027 and 120-127. Slot 12 is then no longer available for use since its references have been used (borrowed) by the module in slot 02. Additional examples of I/O addressing can be found in Appendix B.

GEK-90842

pc-s1-83-0068

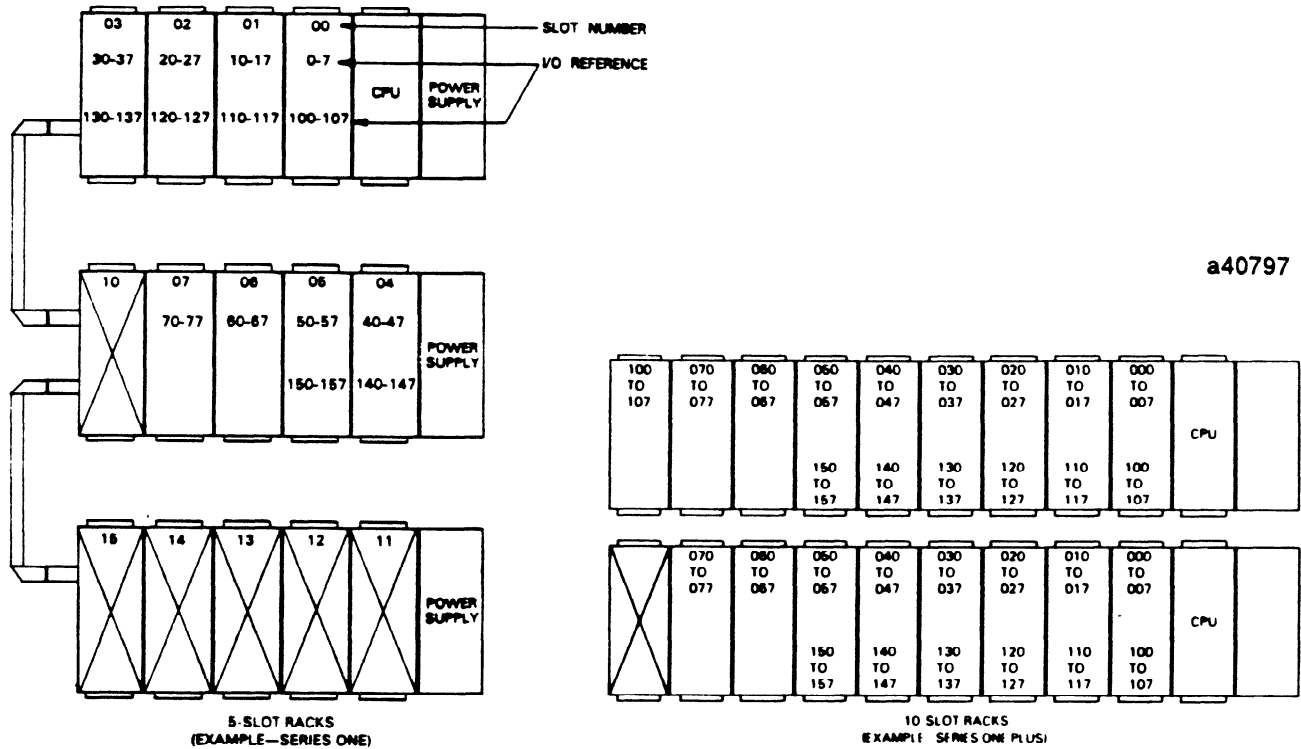

Figure 6-4. Example of 16 Circuit I/O References

NOTE

When using the maximum number of 16 point I/O modules possible, the slots marked with an X are no longer available for system use.

I/O Interface Cable Cross Reference List

The following list provides a reference to the available I/O Interface cables and the module or modules with which they may be used.

Cable Description

IC610CBL105
24 Pin Connector
10' (3 meters)

IC610CBL107
32 Pin Connector
10' (3 meters)

Module Description

IC610MDL105 Thumbwheel Interface
IC610MDL106 High Density Input
IC610MDL156 High Density Output
IC610MDL110 High Speed Counter

I/O Module Catalog Numbers

Table 6-1 is a list of catalog numbers for Series One/Series One Plus I/O modules.

Table 6-1. I/O Module Catalog Numbers

DESCRIPTION	CATALOG NUMBER
<u>I/O Modules - Input</u>	
115 V ac Input, 8 Circuits	IC610MDL125
230 V ac Input, 8 Circuits	IC610MDL127
115 V ac Isolated Input, 4 Circuits	IC610MDL126
24 V dc Sink Input, 8 Circuits	IC610MDL101
24 V dc Sink Input, 16 Circuits	IC610MDL106 (2)
24 V dc Sink Load Input, 16 Circuits	IC610MDL107 (1)
24 V ac/dc Source Input, 8 Circuits	IC610MDL111
24 V ac/dc Source Input, 16 Circuits	IC610MDL112 (1) (3)
Analog Input, 4 Channels	IC610MDL116
<u>I/O Modules - Output</u>	
115/230 V ac Output, 8 Circuits	IC610MDL175
115/230 V ac Isolated Output, 4 Circuits	IC610MDL176
24 V dc Sink Output, 8 Circuits	IC610MDL151
24 V dc Sink Output, 16 Circuits	IC610MDL156 (2)
24 V dc Sink Output, 16 Circuits	IC610MDL157 (1)
24 V dc 2 Amp Sink Output, 4 Circuits	IC610MDL153
24 V dc 2 Amp Sink/Source Output, 4 Circuits	IC610MDL154
24 V dc Source Output, 8 Circuits	IC610MDL155
24 V dc Source Output, 16 Circuits	IC610MDL158 (1)
Relay Output, 8 Circuits	IC610MDL180
Relay Output, 16 Circuits	IC610MDL182 (1)
Analog Output, 2 Channels	IC610MDL166
<u>I/O Modules - Special</u>	
24 V dc Input/Output, 4 In/4 Out	IC610MDL103
24 V dc Sink Input/Relay Output, 4 In/4 Out	IC610MDL104
Thumbwheel Interface	IC610MDL105 (2)
High Speed Counter	IC610MDL110 (4)
Fast Response I/O, 4 In/2 Out	IC610MDL115
I/O Simulator, 8 Input Circuits	IC610MDL124
<u>I/O Modules - UL Listed</u>	
115 V ac Input, 6 Circuits	IC610MDL135
Relay Output, 5 Circuits	IC610MDL181
115 V ac Output, 6 Circuits	IC610MDL185

1. Removable terminal board for I/O Wiring.
2. Connects to I/O through 24 pin connector on faceplate.
3. This module can also be used as a sink input. The user must provide the power source to operate the field devices.
4. Connects to I/O through a 32 pin connector on faceplate.

GEK-90842

I/O Module Specifications and Wiring

The remainder of this chapter describes the available I/O modules for the Series One and Series One Plus PCs.

115 V ac Input IC610MDL125

This module provides 8 circuits each designed to receive a single discrete (ON/OFF) signal from user supplied devices. Typical input devices include limit switches, pushbuttons, selector switches, and relay contacts. The 8 circuits are divided into two groups of 4 circuits each. Each group can be supplied from a separate power source. Power to operate the field devices must also be supplied by the user. Figure 6-5 provides wiring information for this module. Following are specifications for each of the 8 circuits.

Input Points	8
Operating Voltage	97-132 V ac
AC Frequency	47-63 Hz
Input Current	15 mA @ 60 Hz 11.5 mA @ 50 Hz
Input Impedance	9.5K ohms
ON Level	Above 80 V ac
OFF Level	Below 20 V ac
OFF to ON Response	10-30 ms
ON to OFF Response	10-60 ms
Circuit Indicator	Field Side
Internal Power Consumption	10 mA @ 9 V dc
Units of Load	1 Unit @ 9 V dc
Weight	5 oz (140 g)

pc-s1-83-0037

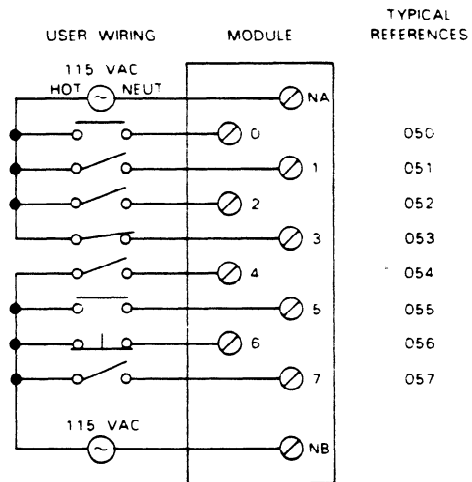

- TYPICAL REFERENCES
- 050
 - 051
 - 052
 - 053
 - 054
 - 055
 - 056
 - 057

WIRING DIAGRAM

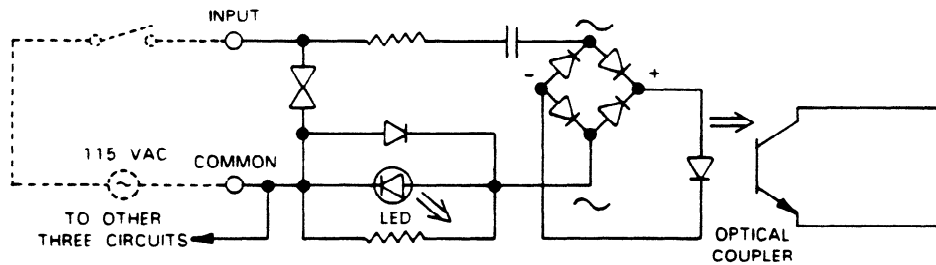

SAMPLE INPUT CIRCUIT

Figure 6-5. Wiring for 115 V ac Inputs

**230 V ac Input
IC610MDL127**

This module provides 8 circuits, each designed to receive a single discrete (ON/OFF) signal from user supplied devices. Typical input devices include limit switches, pushbuttons, selector switches, and relay contacts. The 8 circuits are divided into two groups of 4 circuits each. Each of the 2 groups can be supplied from a separate power source. Power to operate the field devices must also be supplied by the user. Following are specifications for each of these 8 circuits.

Input Points	8
Operating Voltage	180-265 V ac
AC Frequency	47-63 Hz
Input Current	18 mA (265V, 60 Hz), Max.
	11 mA, Typical
Input Impedance	18 K ohms @ 60 Hz
ON Voltage	Above 180 V ac
OFF Voltage	Below 40 V ac
OFF Current	< 2 mA
OFF to ON Response	5-50 ms
ON to OFF Response	5-60 ms
Circuit Indicators	Field Side
Internal Power Consumption	10 mA, 9 V dc
Units of Load	1 Unit @ 9 V dc
Weight	5 oz (140 g)

pc-s1-84-0024

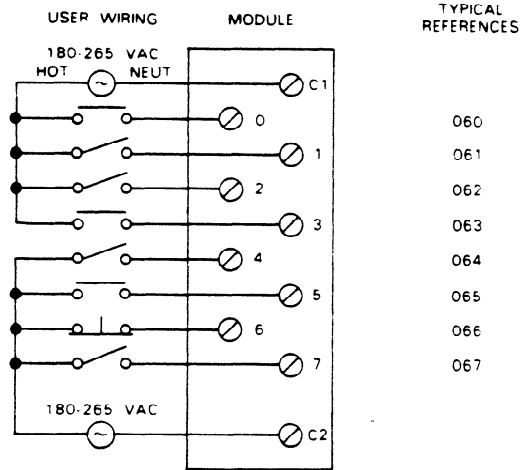

WIRING DIAGRAM

Field connections are made to screw terminals on a terminal block mounted on the faceplate. Each terminal will accept up to one No. 12 AWG wire or two No. 14 wires. The C1 and C2 common terminals are isolated from each other.

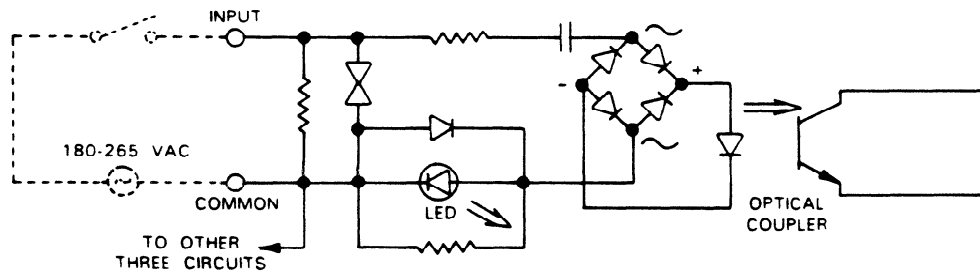

SAMPLE INPUT CIRCUIT

Figure 6-6. Wiring for 230 V ac Inputs

GEK-90842

115 V ac Isolated Input IC610MDL126

This module provides 4 circuits, each designed to receive a single discrete (ON/OFF) signal from user supplied devices. Typical input devices include limit switches, pushbuttons, selector switches, and relay contacts. Each of these circuits is isolated from the other circuits on this module relative to AC power source. The term isolation is not relative to optical-coupler noise and fault isolation which all I/O modules have. Each input is provided with 2 field terminals allowing separate AC power sources (that is, different phases) for each of the four inputs. The sources of AC power must be supplied by the user. Figure 6-7 provides wiring information for this modules.

Although this module consumes 8 discrete references assigned to the I/O slot into which it is inserted, only 4 are actually used. The other 4 can be used internally as coils, but they cannot be provided to hardware I/O modules. Following are specifications for each of the 4 circuits:

Input Points	4
Operating Voltage	97-132 V ac
AC Frequency	47-63 Hz
Input Current	15 ma @ 60 Hz
Input Impedance	10K ohms @ 60 Hz 12K ohms @ 50 Hz
ON Level	Above 80 V ac
OFF Level	Below 20 V ac
OFF to ON Response	10-30 ms
ON to OFF Response	10-60 ms
Circuit Indicator	Field Side
Internal Power Consumption	10 mA @ 9 V dc
Units of Load	1 @ 9 V dc
Weight	4.2 oz (120 g)

pc-s1-83-0032

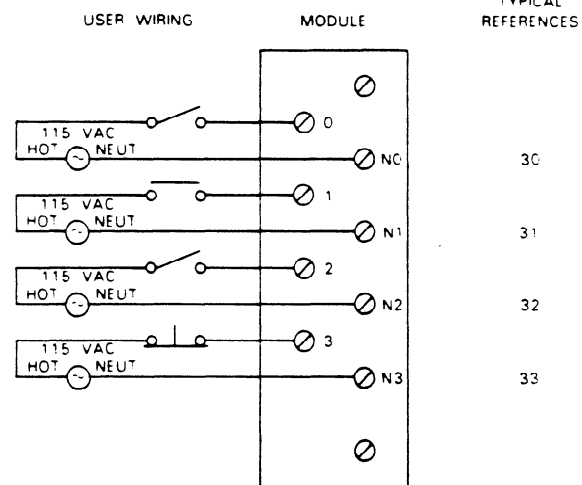

WIRING DIAGRAM

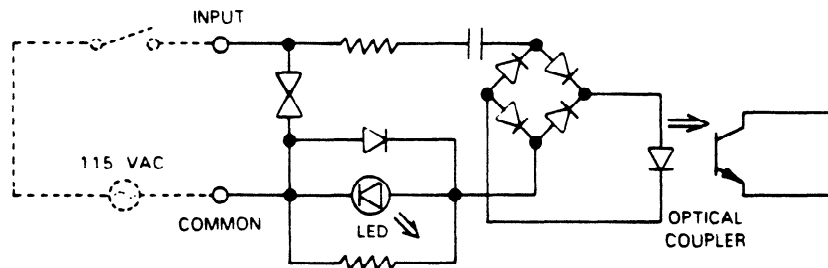

SAMPLE INPUT CIRCUIT

Figure 6-7. Wiring for 115 V ac Isolated Inputs

**24 V dc Sink Input (8 Circuits)
IC610MDL101**

This module provides 8 circuits each designed to receive a single discrete (ON/OFF) signal from user supplied devices. Typical input devices include limit switches, pushbuttons, selector switches, and relay contacts. Power (24 V dc) to sense the state of these inputs is provided by the rack power supply. No external power source is required with this module. All 8 circuits are powered from this one source. Figure 6-8 provides wiring information for this module. Following are specifications for each of the 8 circuits:

Input Points	8
Maximum Voltage (Open Circuit)	36 V dc
Input Current	18 mA
Input Impedance	1.8 K ohms
ON Level*	< 3 V dc
OFF Level*	> 3 V dc
OFF to ON Response	4 to 15 ms
ON to OFF Response	4 to 15 ms
Circuit Indicator	Field Side
Maximum OFF Leakage	3 mA
Minimum ON Current	7 mA
Internal Power Consumption	14 mA for each ON Circuit @ 24 V dc 10 mA @ 9 V dc
Units of Load	1 @ 9 V dc 10 @ 24 V dc
Weight	4.2 oz (120 g)

* Voltage levels measured between common and input terminals (across input device).

pc-s1-83-0034

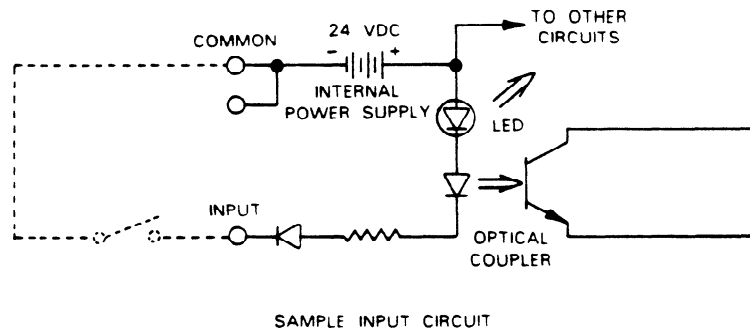
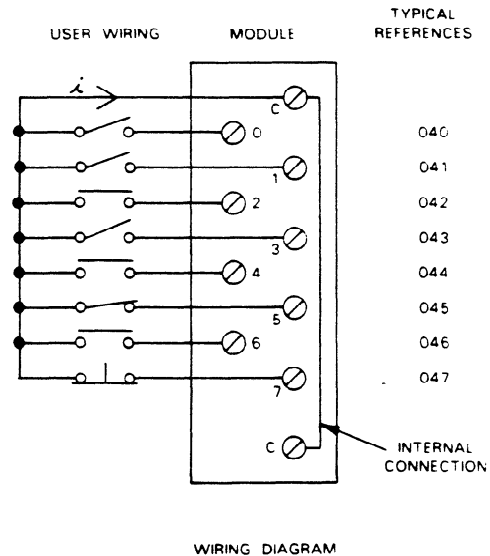

Figure 6-8. Wiring for 24 V ac Sink Inputs

GEK-90842

**24 V dc Sink Input (16 Circuits)
IC610MDL106**

This module provides 16 circuits, each designed to receive a single discrete (ON/OFF) signal from user supplied devices. This module has 16 LED status indicators to reflect the ON or OFF status of each of the 16 circuits. Typical input devices include limit switches, pushbuttons, selector switches, and relay contacts. 24 V dc power to sense the state of these inputs is provided by the rack power supply; therefore, no external power source is required for this module. All 16 circuits are powered from this one source.

Figure 6-10 provides wiring information for this module. The 16 input circuits are connected to user devices through a 24-pin connector. An optional I/O Interface cable, catalog number IC610CBL105, is available for use with this module. Following are specifications for each of the 16 circuits:

Input Points	16
Maximum Voltage (Open Circuit)	36 V dc
Input Current	16 mA
ON Level	0 to 3 V dc
OFF Level	18 to 36 V dc
OFF to ON Response	4 to 15 ms
ON to OFF Response	4 to 15 ms
Maximum OFF Leakage	2 mA
Minimum ON Current	5 mA
Circuit Indicator	Field side
Internal Power Consumption	24 mA @ 9 V dc, Max. (16 circuits ON) 210 mA @ 24 V dc, Max. (16 circuits ON)
Units of Load	3 units @ 9 V dc 21 units @ 24 V dc
Weight	4.2 oz (120 g)

a40566

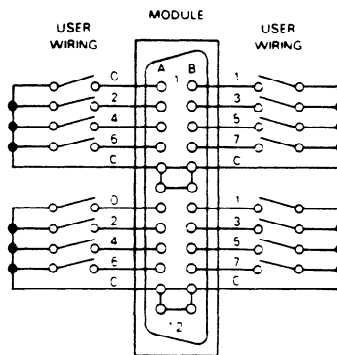

TYPICAL REFERENCES

A	B
030	031
032	033
034	035
036	037
130	131
132	133
134	135
136	137

WIRING DIAGRAM

a40548

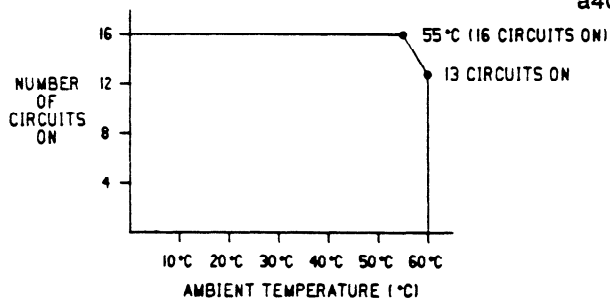
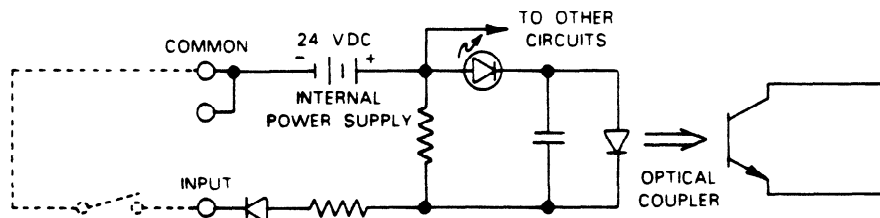

Figure 6-9. I/O Points VS Temperature



SAMPLE INPUT CIRCUIT

Figure 6-10. Wiring for 16 CIRCUIT, 25 V dc Sink Input Module

**24 V dc Sink Load Input (16 Circuits)
With Removable Terminal Board
IC610MDL107**

This module provides 16 circuits, each designed to receive a single discrete (ON/OFF) signal from user supplied devices. This module has 16 LED status indicators to reflect the ON or OFF status of each of the 16 circuits. Typical input devices include limit switches, pushbuttons, selector switches, and relay contacts. 24 V dc power to sense the state of these inputs is provided by the rack power supply; therefore, no external power source is required for this module. The 16 circuits are divided into 2 groups, with each group having its own common terminal. The 2 common terminals are tied together internally.

Figure 6-12 provides wiring information for this module. The 16 input circuits are connected to user devices through a removable socket type terminal board.

Input Points	16
Maximum Voltage (Open Circuit)	36 V dc
Input Current	17 mA
ON Level *	0 to 3 V dc
OFF Level *	19 to 24 V dc
OFF to ON Response	3 to 15 ms
ON to OFF Response	4 to 15 ms
Maximum OFF Leakage	1 mA
Minimum ON Current	5 mA
Circuit Indicator	Field Side
Internal Power Consumption	25 mA @ 9 V dc, Maximum (16 circuits ON) 14 mA for each ON circuit @ 24 V dc
Units of Load	3 units @ 9 V dc 23 units @ 24 V dc
Weight	6.0 oz (170 g)

a40799

*Voltage levels measured between common and input terminals (across input device).

a40798

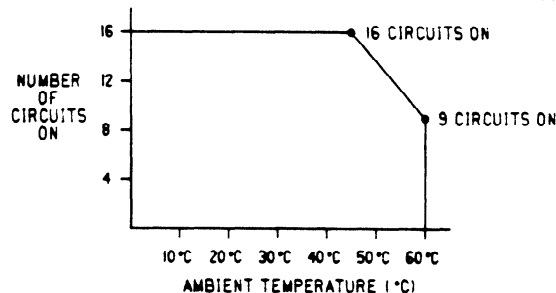

Figure 6-11. I/O Points VS Temperature

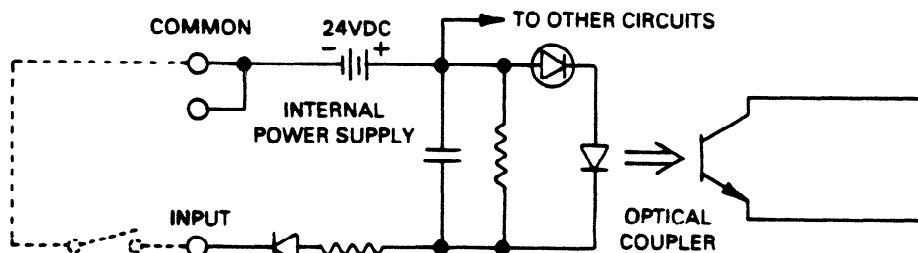
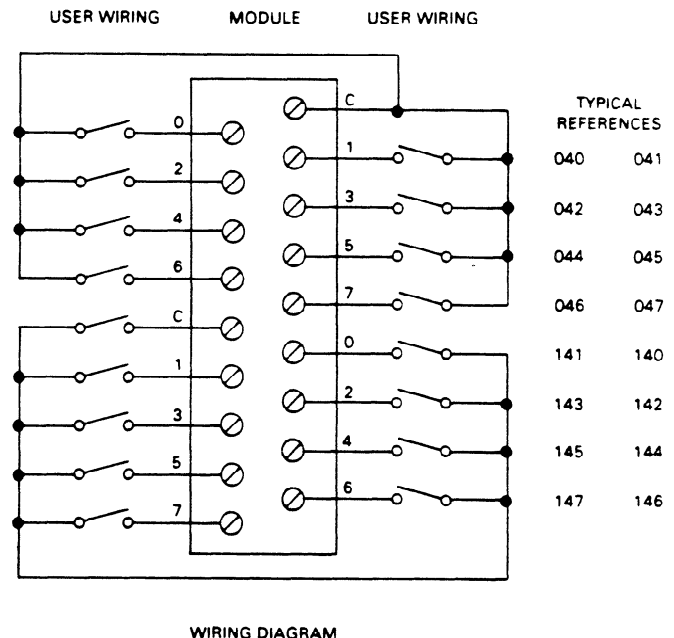

Figure 6-12. Wiring for 16 Circuit, 24 V dc Sink Load Inputs

GEK-90842

**24 V ac/dc Source Input
IC610MDL111**

This module provides 8 input circuits, each designed to receive a single discrete (ON/OFF) signal from user supplied devices. Typical input devices include pushbuttons, limit switches, selector switches and relay contacts. These input circuits can interface to either 24 V ac signals or 24 V dc source-type signals, thereby allowing the module to interface to input devices that provide their own voltage. Following are specifications for each of the 8 circuits.

	AC INPUT	DC INPUT
Input Voltage	20 to 28 V ac, 50-60 Hz	20-28 V dc (Source)
Input Current	19 mA (maximum) 13 mA Typical	19 mA (maximum) 13 mA Typical
ON Level	20 to 28 V ac	20 to 28 V dc
OFF Level	0 to 6 V ac	0 to 6 V dc
OFF to ON Response	5 to 50 ms	6 to 30 ms
ON to OFF Response	5 to 60 ms	5 to 60 ms
Circuit Indicator	Field Side	Field Side
Internal Power Consumption		9 V dc, 10 mA (supplied by rack power supply)
Units of Load		1 @ 9 V dc
Weight		5 oz (140 g)

a42681

User devices are connected to screw terminals on the faceplate of this module. Each screw terminal will accept up to one No. 12 AWG wire or two No. 14 AWG wires. The ON/OFF state of each circuit is indicated by an LED located in the field side of each circuit. The 8 circuits are divided into 2 groups of 4, each with its own common. The two commons, CA and CB are isolated from each other internally. Each input can accept either an AC input or a DC input.

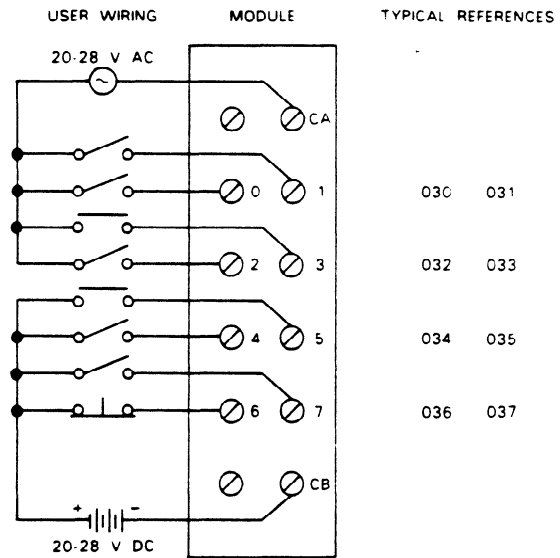

a42682

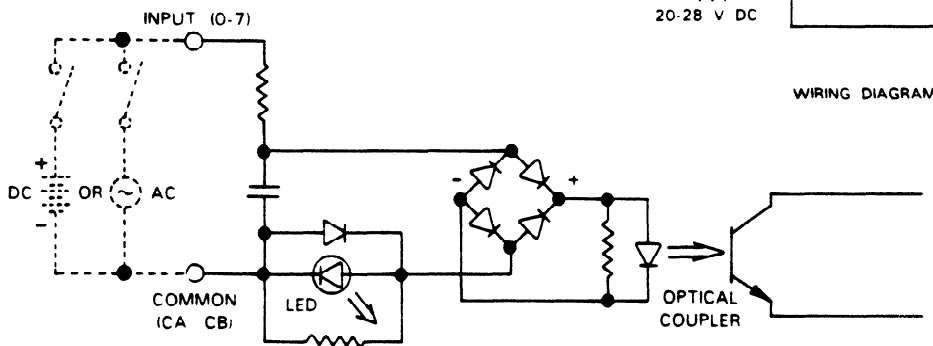

Figure 6-13. Wiring for 24 V ac/dc Inputs

**24 V ac/dc Source Input (16 Circuits)
With Removable Terminal Board
IC610MDL112**

This module provides 16 input circuits, with LED indicators, each designed to receive a single discrete (ON/OFF) signal from user supplied devices. Typical input devices include pushbuttons, limit switches, selector switches and relay contacts. These input circuits can interface to either 24 V ac signals or 24 V dc source-type signals, thereby allowing the module to interface to input devices that provide their own voltage. In addition, the module can be connected as a sink input. When using the sink configuration, the user must supply the source of power for the input devices, as when used in the source input configuration. Following are specifications for each of the 16 circuits.

	AC INPUT	DC INPUT
Input Voltage (Source or Sink)	14 to 30 V ac, 50-60 Hz	20-28 V dc
Input Current	12 mA @ 24 V ac	12 mA @ 24 dc
ON Level	14 to 30 V ac	14 to 30 V dc
OFF Level	0 to 3 V ac	0 to 3 V dc
OFF to ON Response	5 to 30 ms	5 to 25 ms
ON to OFF Response	5 to 30 ms	5 to 25 ms
Circuit Indicator	Logic Side	Logic Side
Internal Power Consumption		9 V dc, 130 mA (maximum) Typical, 25 mA + 4.5 mA for each ON circuit
Units of Load		13
Weight		6 oz (170 g)

a40800

User devices are connected to screw terminals on the removable connector mounted on the faceplate of this module. Each screw terminal will accept up to one No. 12 AWG wire or two No. 14 AWG wires. The On/OFF state of each circuit is indicated by an LED located in the logic side of each circuit. The 16 circuits are divided into 2 groups of 8, each with its own common. The two commons, CA and CB are isolated from each other internally. Each input can accept either an AC input or a DC input.

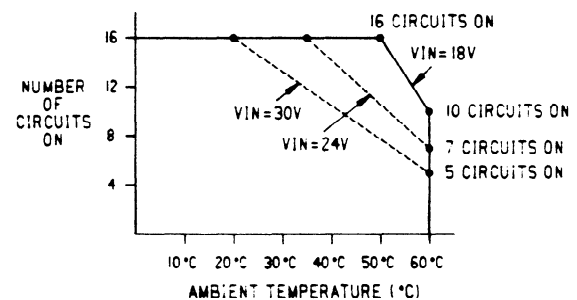
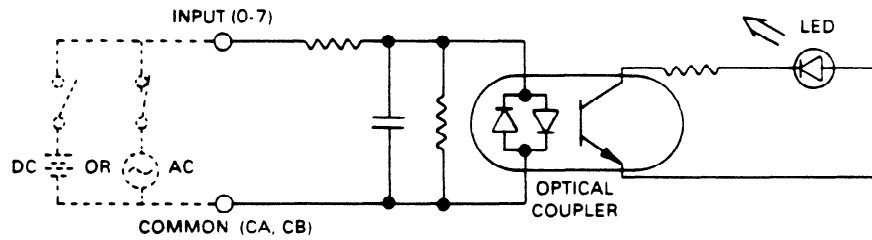
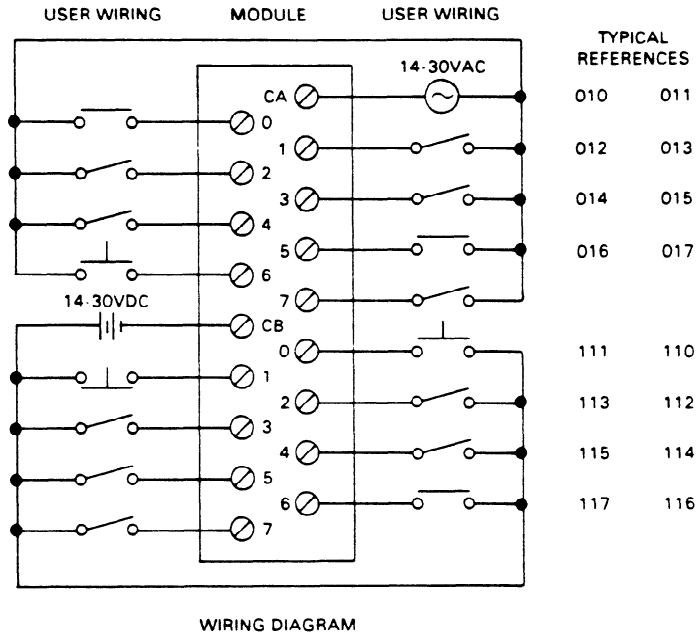

Figure 6-14. I/O Points vs Temperature Chart

a40801



SAMPLE INPUT CIRCUIT
 FIGURE 6 15 WIRING FOR 16 CIRCUIT 24 VAC /DC SOURCE
 LOAD INPUTS

Figure 6-15. Wiring for 16 Circuit 24 V ac/dc Source Load Inputs

**115/230 V ac Output
IC610MDL175**

This module provides 8 circuits each capable of controlling user supplied discrete (ON/OFF) loads. Typical loads include relay coils, motor starters (up to No. 3), solenoid valves and indicator lights. The 8 circuits are divided into 2 groups of 4 circuits each. Each group can be supplied from a separate power source. Power to operate the field devices must also be supplied by the user. Figure 6-17 provides wiring information for this module. Following are specifications for each of the 8 circuits:

CAUTION

If this module is wired incorrectly or the listed specifications are exceeded, any damage incurred by the module or user devices connected to the module may not be covered by warranty.

Output Points	8
Operating Voltage	97-265 V ac
AC Frequency	47-63 Hz
Maximum Current*	1 amp
Maximum Leakage Current	1.2 mA @ 220V, 60 Hz 0.5 mA @ 110V, 60 Hz
ON Voltage Drop	0.9V @ 1 amp 0.8V @ 0.5 amp
Smallest Recommended Load	25 mA
Maximum Inrush	10 amps for 16 ms 5 amps for 100 ms
OFF to ON Response	1 ms
ON to OFF Response	8-10 ms (1/2 cycle)
Circuit Indicator	Logic Side
Fuses (Internal, Soldered)	(2) 5 amp fast blow (one on each group of 4)
Internal Power Consumption	20 mA for each ON Circuit @ 9 V dc
Units of Load	16 @ 9 V dc
Weight	6.4 oz (180 g)

*Maximum load current is dependent upon ambient temperature as shown on the chart in figure 6-16.

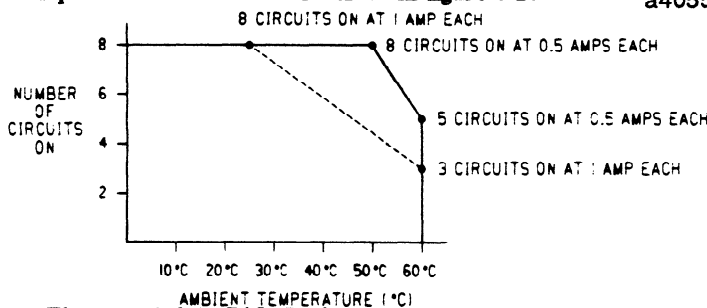
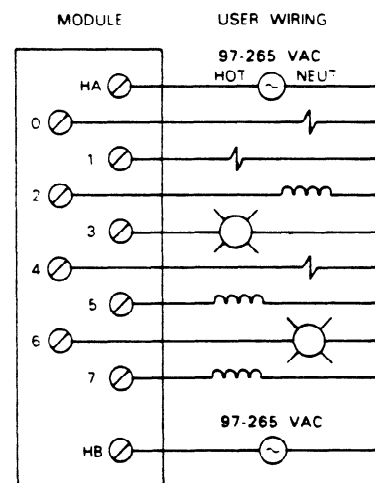

Figure 6-16. I/O Points vs Temperature

pc-s1-83-0033

TYPICAL REFERENCES



WIRING DIAGRAM

a40555

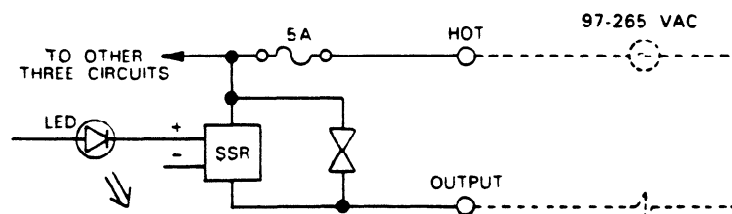

Figure 6-17. Wiring for 115/230 V ac Outputs

GEK-90842

**115/230 V ac Isolated Output
IC610MDL176**

This module provides 4 circuits each capable of controlling user supplied discrete (ON/OFF) loads. Typical loads include relay coils, motor starters (up to No. 4), solenoid valves, and indicator lights. Each of these circuits is isolated from the other circuits on this module relative to AC power source. The term isolation is not relative to optical-coupler noise and fault isolation which all I/O modules have. Each output is provided with 2 field terminals allowing separate AC power sources (that is, different phases) for each of the 4 outputs. These power sources must be supplied by the user. Figure 6-19 provides wiring information for this module. Although this module consumes 8 discrete references assigned to the slot into which it is placed, only 4 are actually used. The other 4 can be used internally as coils, but they cannot be provided to hardware I/O modules. Following are specifications for each of the four circuits:

Outputs	4
Operating Voltage	97-265 V ac
AC Frequency	47-63 Hz
Maximum Current*	2 amps
Maximum Leakage Current	7 mA @ 220V, 60 Hz 3.5 mA @ 110V
Maximum Inrush	20 amps for 16 ms
ON Voltage Drop	.8V @ 2 amps
Smallest Recommended Load	25 mA
OFF to ON Response	1.0 ms
ON to OFF Response	8-10 ms (1/2 Cycle)
Circuit Indicator	Logic Side
Fuses (Internal)	(4) 3 amp fast blow
(each circuit, Replaceable)	
Internal Power Consumption	12 mA @ 9 V dc
Units of Load	8 units @ 9 V dc
Weight	5 oz (140 g)

* Maximum load current is dependent upon ambient temperature as shown on the chart in figure 6-18.

a40549

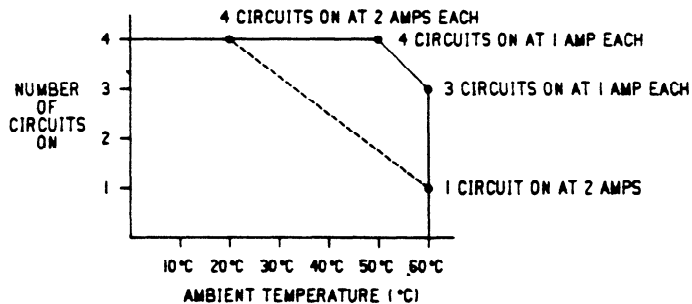
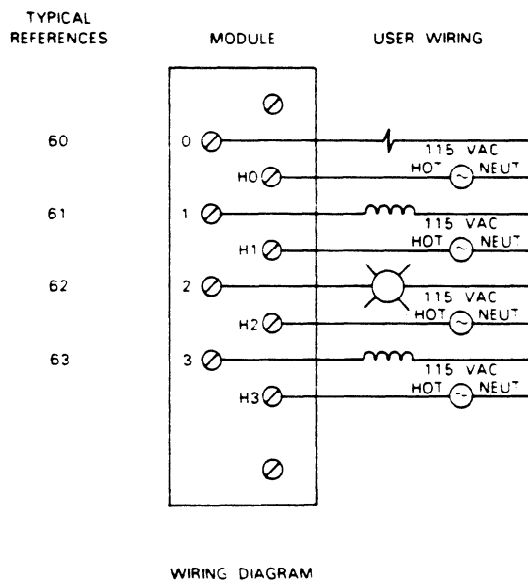

Figure 6-18. I/O Points vs Temperature Chart

pc-s1-83-0038



WIRING DIAGRAM

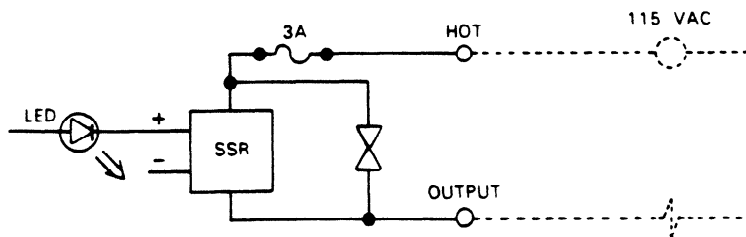

Figure 6-19. Wiring for 15 V ac Isolated Outputs

**24 V dc Sink Output (8 Circuits)
IC610MDL151**

This module provides 8 circuits each capable of controlling user supplied discrete (ON/OFF) loads. Typical loads include relay coils, motor starters, solenoid valves, and indicator lights. The 8 circuits are provided referenced to a single DC power source, that must be supplied by the user. Figure 6-21 provides wiring information for this module. Since current flows from the load into the field terminal for each circuit when the output is energized, these circuits are referred to as sink DC outputs. Following are specifications for each of the 8 circuits:

Output Points	8
Operating Voltage	5-24 V dc
Peak Voltage	45 V dc
Maximum Current*	0.5 amp
Max. Leakage Current	0.1 mA @ 40 V dc
ON Voltage Drop	0.8V @ 0.5 amp 0.65V @ 0.1 amp
Smallest Recommended Load	1 mA
Maximum Inrush	3 amp for 20 ms 1 amp for 100 ms
OFF to ON Response	100 msec
ON to OFF Response	100 msec
Circuit Indicator	Logic Side
Fuses (Internal)	(2) 3 amp (one on each group of 4)
Internal Power Consumption	20 mA @ 9 V dc. 3 mA for each ON Circuit @ 24 V dc
Units of Load	2 units @ 9 V dc 3 units @ 24 V dc
Weight	4.2 oz (120 g)

pc-s1-83-0035

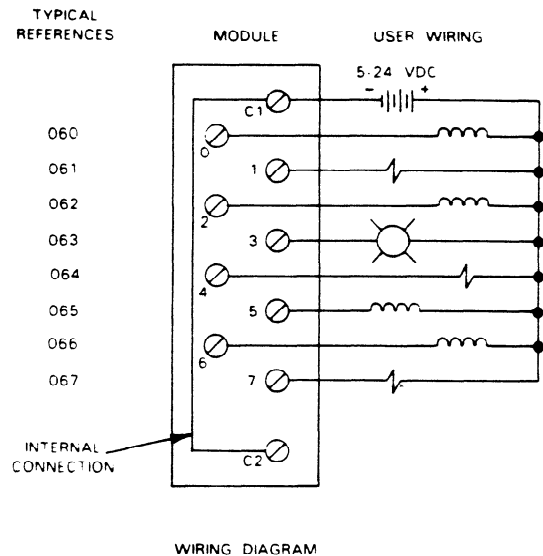

* Max. load current is dependent upon ambient temperatures as shown in fig. 6-20.

a40550

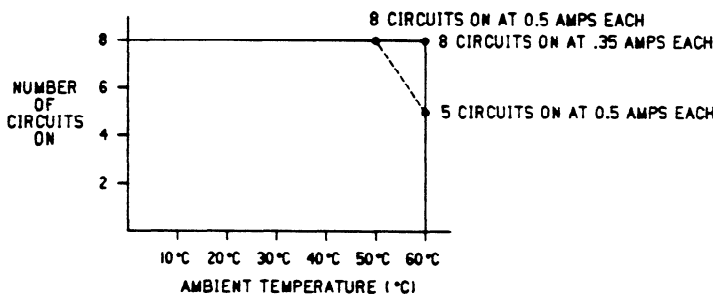

Figure 6-20. I/O Points vs Temperature Chart

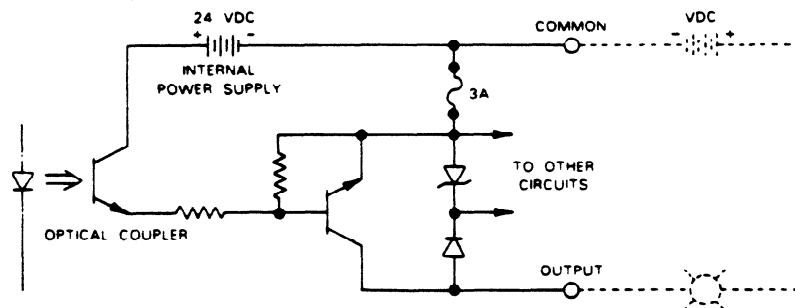

Figure 6-21. Wiring for 24 V dc Sink Outputs

GEK-90842

**24 V dc Sink Output (16 Circuits)
IC610MDL156**

This module provides 16 circuits, each designed to be capable of controlling user supplied discrete (ON/OFF) loads. There are 16 LEDs on the faceplate, which are status indicators to reflect the ON or OFF status of each of the circuits. Typical loads include relay coils, motor starters, solenoid valves, and indicator lights. The 16 circuits are referenced to a single DC power source that must be supplied by the user. Output switching capacity of this module is 0.5 A at 24 V dc. The output switching circuitry is arranged in 4 groups with 4 circuits in each group. Each group is protected by a 3 amp fuse.

The 16 circuits are connected to user loads through an optional I/O Interface cable, Catalog number IC610CBL105, which connects to a 24-pin connector mounted on the module faceplate. Figure 6-23 provides wiring information for this module. Following are specifications for each of the 16 circuits.

Output Points	16
Operating Voltage	5-24 V dc
Peak Voltage	40 V dc
ON Voltage Drop, Typical	0.9 V dc @ 0.5 amp
ON Voltage Drop, Maximum	1.5 V dc @ 0.5 amp
Maximum Current*	0.5 amp
Maximum Leakage Current	0.1 mA @ 40 V dc
Maximum Inrush	3 amp for 20 ms 1 amp for 100 ms
OFF to ON Response	0.1 ms
ON to OFF Response	0.1 ms
Fuse (Internal)	3 amp (In Output Common Line, one for each group of 4).
Internal Power Consumption	40 mA @ 9 V dc, Maximum (16 outputs ON) 96 mA @ 24 V dc, Maximum (16 outputs ON)
Units of Load	4 units @ 9 V dc 10 units @ 24 V dc
Weight	3.9 oz (110 g)

*Maximum load current is dependent upon ambient temperature as shown in figure 6-22.

a40552

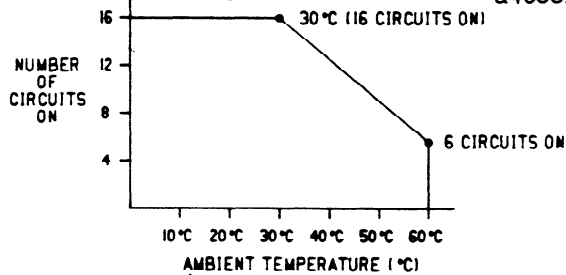
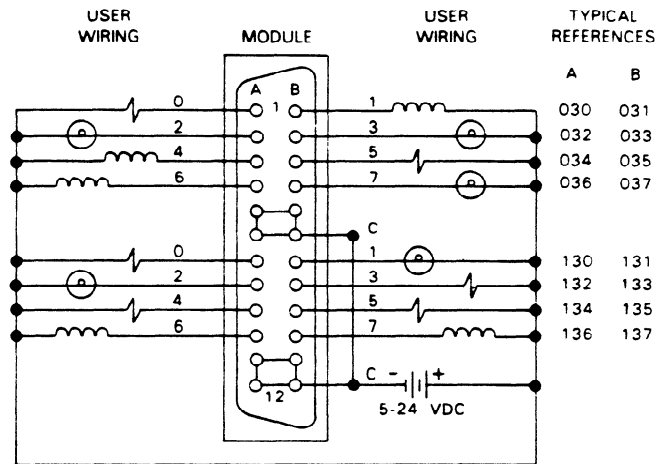

Figure 6-22. I/O Points vs Temperature Chart

pc-s1-83-0070



WIRING DIAGRAM

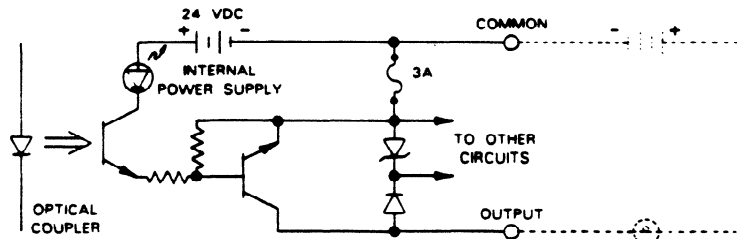

Figure 6-23. Wiring for 16 Circuit 24 V dc Sink Outputs

**24 V dc Sink Output (16 Circuits)
With Removable Terminal Board
IC610MDL157**

This module provides 16 circuits, each designed to be capable of controlling user supplied discrete (ON/OFF) loads. There are 16 LEDs on the faceplate, which are status indicators to reflect the ON or OFF status of each of the circuits. Typical loads include relay coils, motor starters, solenoid valves, and indicator lights. The 16 circuits are referenced to a single DC power source that must be supplied by the user. Output switching capacity of this module is 0.5 A at 24 V dc. The output switching circuitry is arranged in 2 groups with 8 circuits in each group. Each group is protected by a 3 amp fuse.

The 16 circuits are connected to user loads through a removable socket type terminal board. Figure 6.25 provides wiring information for this module. Following are specifications for each of the 16 circuits:

Output Points	16
Operating Voltage	5-24 V dc
Peak Voltage	40 V dc
ON Voltage Drop, Typical	1.0 V dc @ 0.5 amp
ON Voltage Drop, Maximum	2.0 V dc @ 0.5 amp
Maximum Current*	0.5 amp
Maximum Leakage Current	0.11 mA @ 40 V dc
Maximum Inrush	3 amp for 20 ms 1 amp for 100 ms
OFF to ON Response	0.1 ms
ON to OFF Response	0.1 ms
Fuse (Internal)	3 amp (In Output Common Line, one for each group of 8)
Internal Power Consumption	9 V dc: 3 mA + 2.3 mA for each ON circuit 24 V dc: 6mA for each ON circuit
Units of Load	4 units @ 9 V dc 10 units @ 24 V dc
Weight	5.6 oz (160 g)

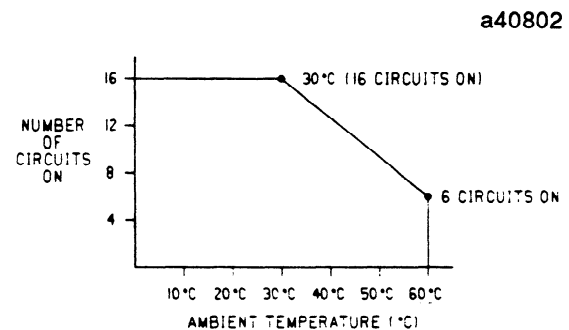
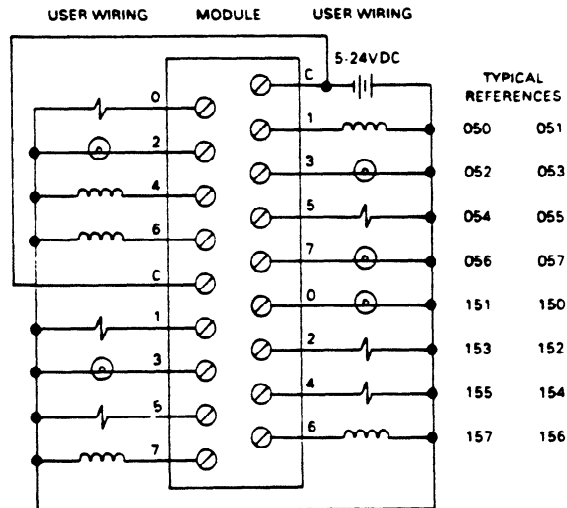

Figure 6-24. I/O Points vs Temperature Chart

* Maximum load current is dependent upon ambient temperature as shown in figure 6.24.

GEK-90842

a40803



The following rules should be used when applying this module.

1. Each group of 8 outputs is limited to 2A total current.
2. The maximum current for each array of 4 outputs (0-3), (4-7) is:

1 point on - .7 amps,
3 points on - .4 amps each,

2 points on - .5 amps each
4 points on - .35 amps each

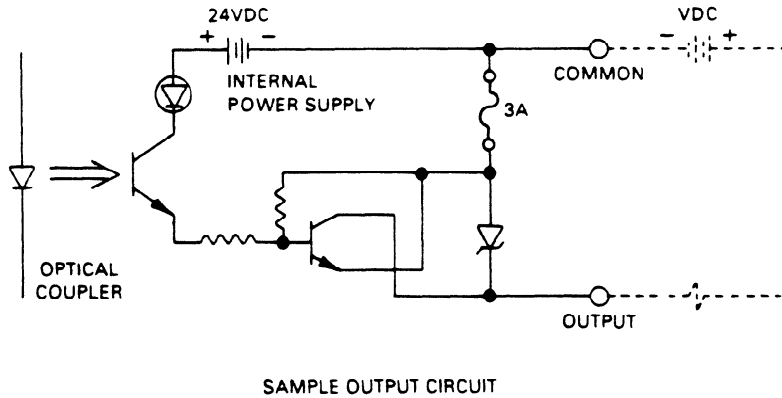

Figure 6-25. Wiring for 16 Circuit 24 V dc Sink Outputs

**24 V dc 2 Amp Sink Output
IC610MDL153**

This module provides 4 fused 24 V dc sink output circuits each capable of controlling user supplied discrete (ON/OFF) loads. Each circuit is rated at 2 amps continuous current. Typical loads include motor starters, relay coils, solenoid valves, and indicator lights. The circuits on this module are referred to as sink outputs since current flows from the load into the field terminal for each circuit when the output is energized. Field connections are made to screw terminals on a terminal block mounted on the faceplate. Each terminal will accept up to one No. 12 AWG wire or two No. 14 AWG wires. The ON/OFF state of each circuit is indicated by a corresponding LED. This module, although having only 4 output circuits, will consume 8 consecutive discrete references. The 4 references not available as "real world" outputs can be used as internal coils. Following are specifications for each of the four output circuits.

Output Points	4
Operating Voltage	5 to 24 V dc
Peak Voltage	45 V dc
ON Voltage Drop	.15 V dc @ 1 amp .6 V dc @ 4 amp
Maximum Current*	2 amps
Maximum Leakage Current	< .4 mA @ 40 V dc
OFF to ON Response	.1 ms
ON to OFF Response	.1 ms
Circuit Indicator	Logic Side
Fuses, Internal	5 amp (1 for each circuit) Replaceable
Internal Power Consumption	5 mA @ 24 V dc 12 mA @ 9 V dc
Units of Load	1 unit @ 24 V dc 2 units @ 9 V dc
Weight	4.2 oz (120 g)

a40551

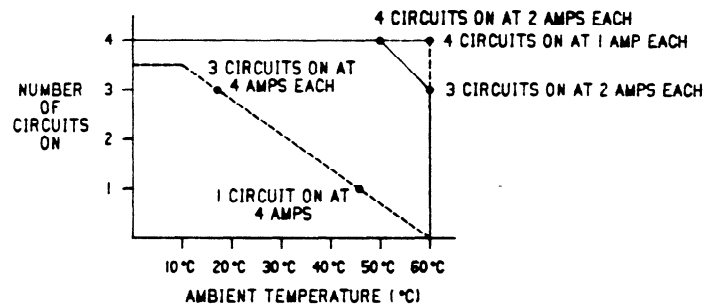

Figure 6-26. I/O Points vs Temperature Chart

*Maximum load current is dependent on ambient temperature as shown in figure 6.26.

pc-s1-84-0022

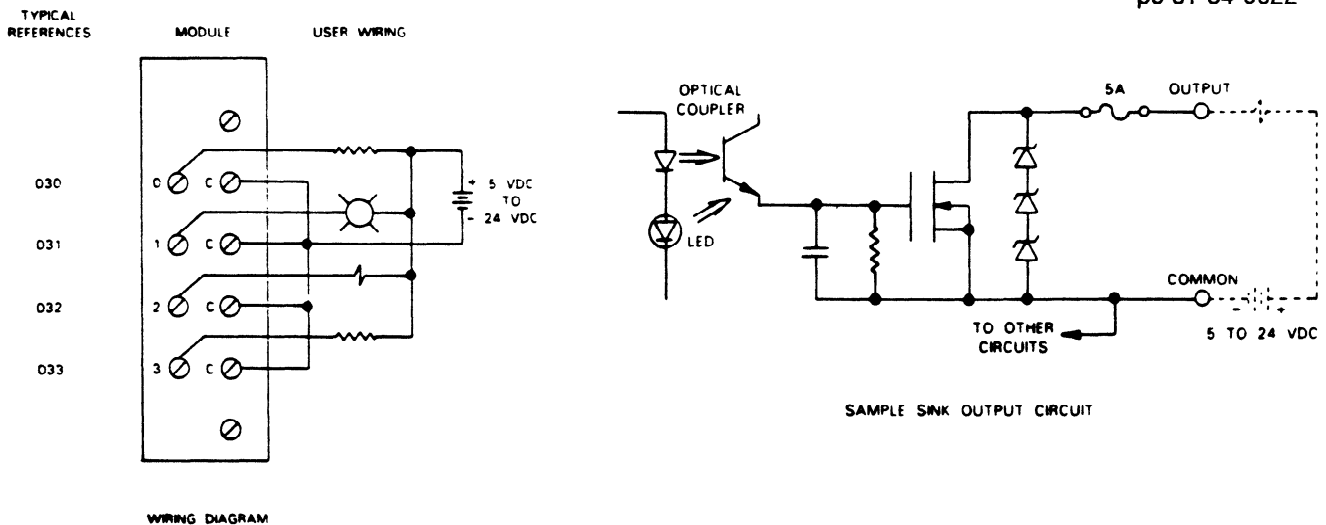

Figure 6-27. Wiring for 24 V dc 2 Amp Sink Outputs

GEK-90842

**24 V dc 2 Amp Sink/Source Output
IC610MDL154**

This module provides 4 isolated, fused 24 V dc sink or source output circuits each capable of controlling user supplied discrete (ON/OFF) loads. Each circuit is rated at 2 amps continuous current. Outputs can be connected in parallel to increase output current capacity. Types of loads that can be controlled by this module would include motor starters, relay coils solenoid valves, and indicator lights. All 4 circuits can be referenced to a separate DC source of power. The circuits on this module can be used as either source outputs or sink outputs, depending on how the load is wired in relation to the load power supply.

Field connections are made to screw terminals on a terminal block mounted on the faceplate. Each terminal will accept up to one No. 12 AWG wire or two No. 14 AWG wires. The ON/OFF state of each circuit is indicated by a corresponding LED on the logic side. This module will consume 8 consecutive discrete references. The 4 references not used as "real world" outputs can be used as internal coils in your program. Following are specifications for each of the four circuits.

Output Points	4
Operating Voltage	5 to 24 V dc
Peak Voltage	45 V dc
Maximum Current*	2 amps Continuous 8 amps Maximum Peak
Maximum Leakage Current	< .4 mA @ 40 V dc
ON Voltage Drop	1 V dc @ 6 amps .6 V dc @ 4 amps .3 V dc @ 2 amps .15 V dc @ 1 amp
OFF to ON Response	.1 ms
ON to OFF Response	.1 ms
Circuit Indicator	Logic Side
Fuses, Internal	5 amp (1 for each circuit) Replaceable
Internal Power Consumed	12 mA @ 9 V dc 30 mA @ 24 V dc
Units of Load	2 units @ 9 V dc 3 units @ 24 V dc

Lamp load should be .8 amps or less.
*Load current (max.) is dependent on ambient temperature as shown below.

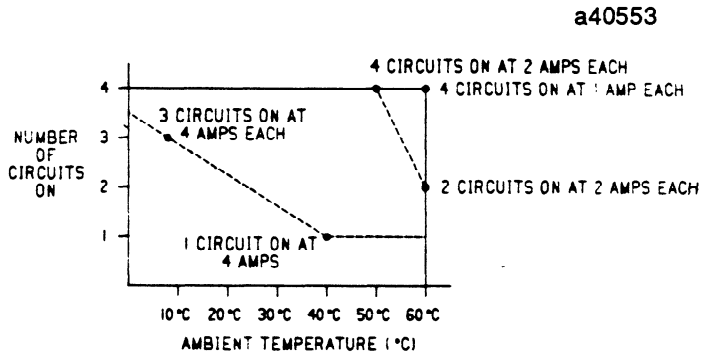
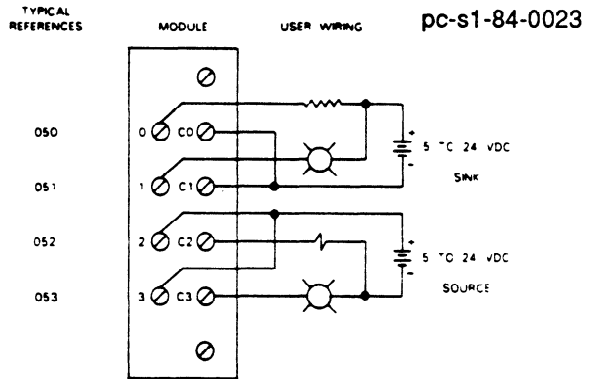

Figure 6-28. I/O Points vs Temperature



Although not shown as such, the 4 circuits are isolated from each other and can be connected to separate power sources.

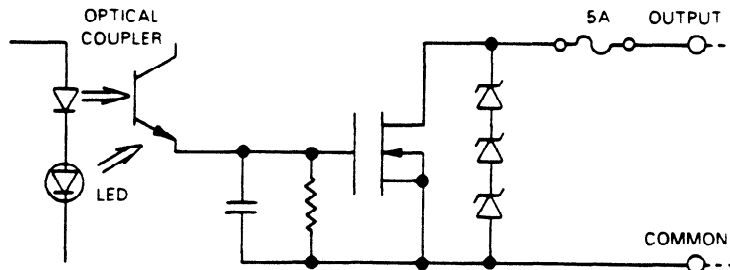

Figure 6-29. Wiring of 24 V dc 2 Amp Sink/Source Output

24 V dc Source Output IC610MDL155

This module provides eight 24 V dc source output circuits, each capable of controlling user supplied discrete (ON/OFF) loads. Each circuit is rated at 0.5 amps continuous current. Typical loads that can be controlled by this module are motor starters, relay coils, solenoid valves, and indicator lights. The output switching circuits on the module are arranged in 2 groups with 4 circuits in each group. Each group of 4 output circuits is protected by a 3 amp fuse. All 8 circuits should be referenced to a single source of dc power. Field connections are made to screw terminals on a terminal block mounted on the module's faceplate. Each terminal will accept up to one No. 12 AWG wire or two No. 14 AWG wires. The operating state, either ON or OFF, is indicated by a corresponding LED viewed on the module's faceplate. Following are specifications for each of the 8 circuits.

Output Points	8
Operating Voltage	5 to 24 V dc
Peak Voltage	40 V dc
ON Voltage Drop	1.0 V @ 0.5 amp 0.75 V @ 0.1 amp
Maximum Current*	0.5 amps
Maximum Leakage Current	0.1 mA at 24 V dc
Smallest Recommended Load	1.0 mA
OFF to ON Response	100 μ sec
ON to OFF Response	100 μ secs
Circuit Indicator	Logic Side
Fuses (Internal)	(2) 3 amp (in output common line, one for each group of 4 circuits)
Internal Power Consumption	30 mA maximum @ 9 V dc, Supplied by rack power supply
Units of Load	3 Units @ 9 V dc
Weight	4.2 oz (120 g)

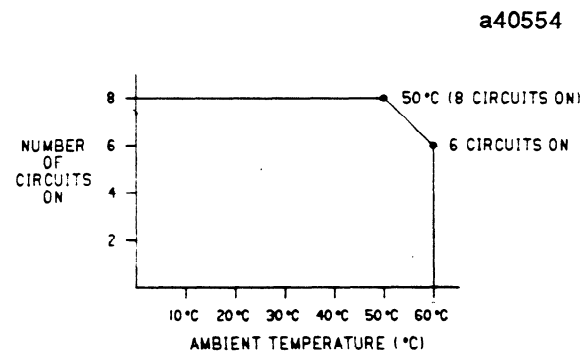

Figure 6-30. I/O Points vs Temperature Chart

*Maximum load current is dependent on ambient temperature as shown in figure 6.30.

a40626

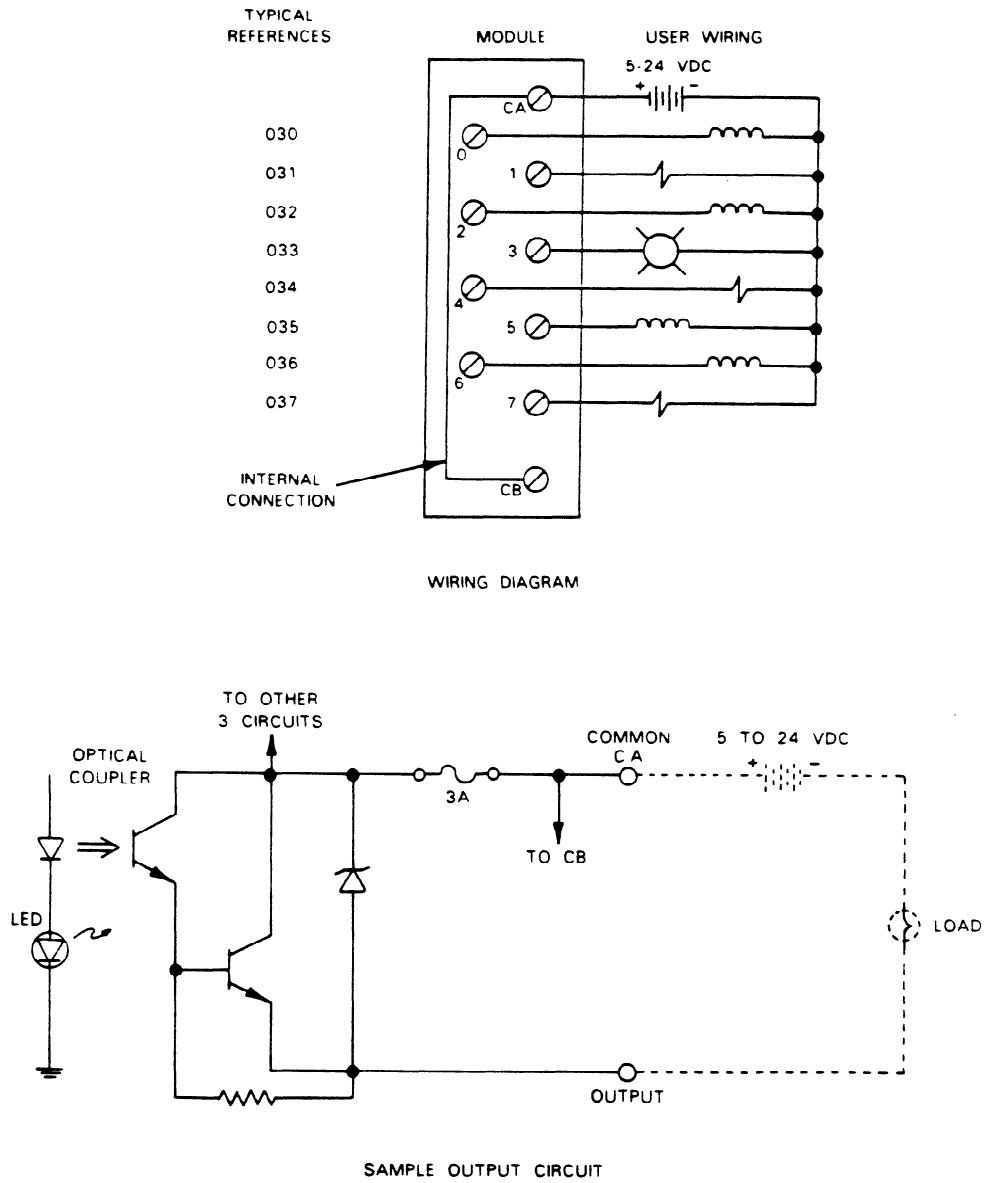

Figure 6-31. Wiring for 24 V dc Source Outputs

**24 V dc Source Output (16 Circuits)
With Removable Terminal Board
IC610MDL158**

This module provides sixteen 24 V dc source output circuits, each capable of controlling user supplied discrete (ON/OFF) loads. The output switching capacity of this module is 0.5 amps at 24 V dc. Typical loads that can be controlled by this module are motor starters, relay coils, solenoid valves, and indicator lights. The output switching circuits on the module are arranged in 2 groups with 8 circuits in each group. Each group of 8 output circuits is protected by a 5 amp fuse. All 16 circuits can be referenced to a single source of dc power or each group of 8 can be referenced to a separate source of power. Field connections are made to screw terminals on a removable terminal board mounted on the module's faceplate. Each terminal will accept up to one No. 12 AWG wire or two No. 14 AWG wires. The operating state, either ON or OFF, is indicated by a corresponding LED viewed on the module's faceplate. Following are specifications for each of the 16 circuits.

a40805

Output Points	16
Operating Voltage	5 to 24 V dc
Peak Voltage	40 V dc
ON Voltage Drop	Maximum 1.5 V dc 0.8 V dc @ 0.5 amp (Typical) 0.7 V dc @ 0.1 amp (Typical)
Maximum Current*	0.5 amps
Maximum Leakage Current	10 mA @ 40 V dc
OFF to ON Response	0.1 ms (Resistive)
ON to OFF Response	1.0 ms (Resistive)
Circuit Indicator	Logic Side
Fuses (Internal)	(2) 5 amp (in output common line, one for each group of 8 circuits)
Internal Power Consumption	12 mA for each ON circuit
Units of Load	20 Units @ 9 V dc
Weight	7.1 oz (200 g)

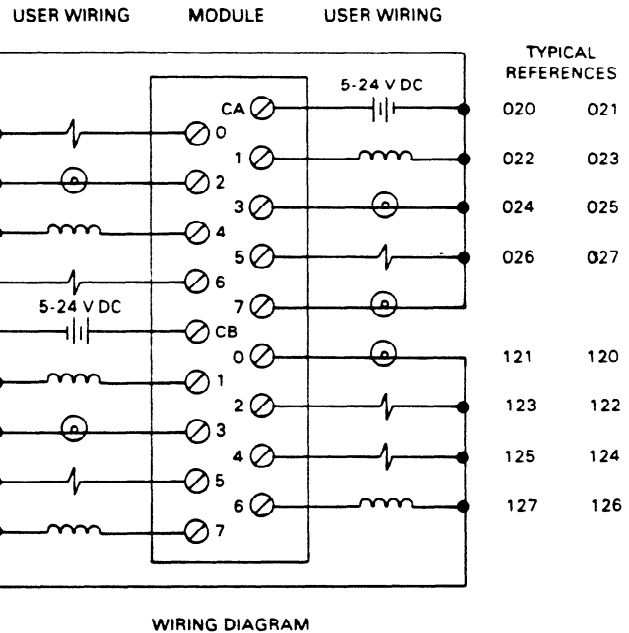

*Maximum load current is dependent on ambient temperature as shown in figure 6.32.

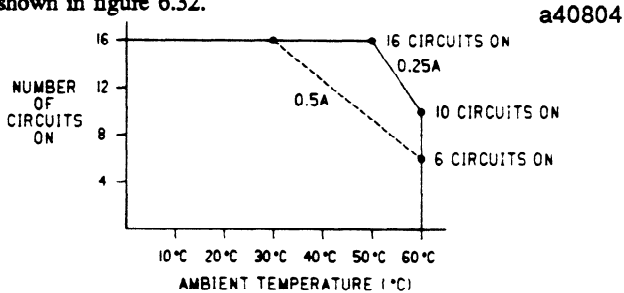

Figure 6-32. I/O Points vs Temperature

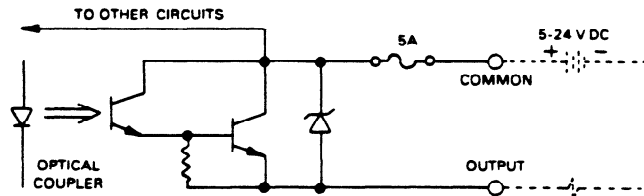

Figure 6-33. Wiring for 24 V dc Source Outputs

GEK-90842

**Relay Output (8 Circuits)
IC610MDL180**

This module provides 8 circuits each capable of controlling user supplied discrete (ON/OFF) loads. Typical loads include relay coils, motor starters, solenoid valves, and indicator lights. Since this module is not designed for a specific current type such as 115 V ac or 24 V dc, it can be used with a wide variety of loads and signal types. The 8 circuits are divided into two groups of 4 circuits each. Each group can be supplied from a separate power source. Power to operate the field devices must also be supplied by the user. Following are specifications for each of the eight circuits:

Outputs	8
Operating Voltage	5 to 265 V ac/dc
AC Frequency	47-63 Hz
Maximum Current*	4 amp (resistive)
Maximum Leakage Current (Across Contacts)	1 mA
Smallest Recommended Load	5 mA
Maximum Inrush	5 amps
OFF to ON Response	5 ms
ON to OFF Response	5 ms
Circuit Indicator	Logic Side
Fuses (Internal)	(2) 10 amp (Replaceable) (one for each group of 4)
Internal Power Consumption	45 mA for each ON Circuit @ 9 V dc
Units of Load	34 units @ 9 V dc
Weight	7 oz (200 g)

*Since non-solid state devices are used as the power switching devices, the following limitations must be observed for reliable operation:

Table 6-2. Maximum Current vs Load Type for Relay Outputs

OPERATING VOLTAGE	MAXIMUM CURRENT FOR LOAD TYPE			TYPICAL LIFE (OPERATIONS)
	RESISTIVE	LAMP	SOLENOID	
220 V ac	4.0 Amp	0.5 Amp	0.5 Amp	100,000
220 V ac		.05 Amp	.05 Amp	800,000
110 V ac	4.0 Amp	0.5 Amp	0.5 Amp	150,000
110 V ac		0.1 Amp	0.1 Amp	650,000
24 V dc	5.0 Amp	0.5 Amp	0.5 Amp	100,000
50 V dc		1.0 Amp	0.1 Amp	100,000
100 V dc	0.5 Amp	.05 Amp	.05 Amp	100,000
250 V dc		0.3 Amp	.03 Amp	100,000

NOTE

Lamp loads are defined as a X10 inrush with a power factor (PF) of 1.00 and when turned OFF represent a PF of 1.00. Solenoids are defined with a X10 inrush, a PF of 0.65, and when turned OFF represent a PF of 0.35.

pc-s1-83-0036

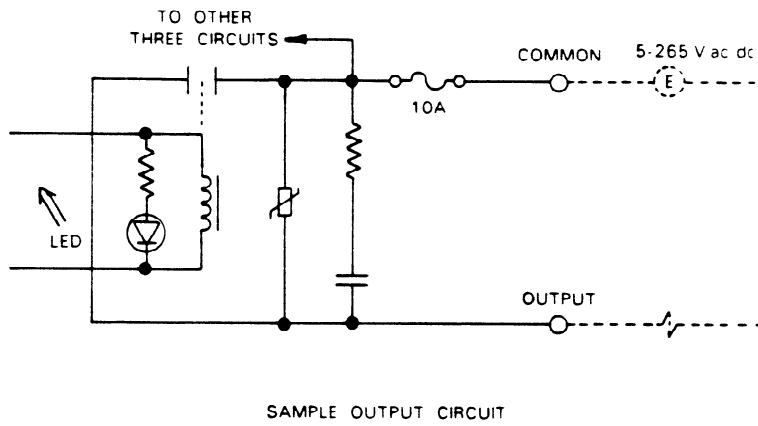
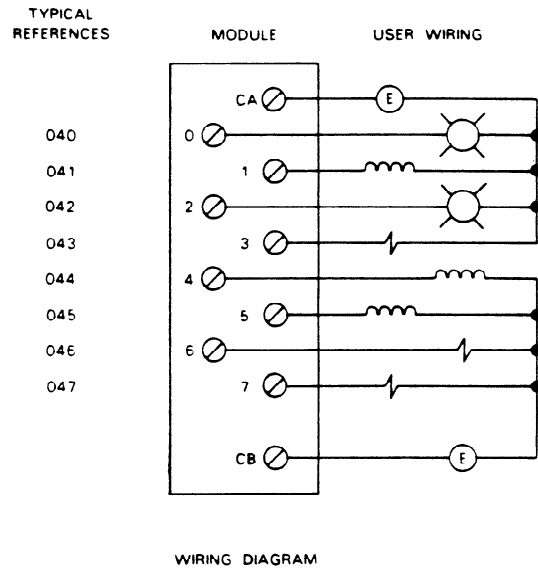

Figure 6-34. Wiring for 8 Circuit Relay Outputs

GEK-90842

**Relay Output (16 Circuits)
With Removable Terminal Board
IC610MDL182**

This module provides 16 circuits each capable of controlling user supplied discrete (ON/OFF) loads. Typical loads include relay coils, motor starters, solenoid valves, and indicator lights. Since this module is not designed for a specific current type such as 115 V ac or 24 V dc, it can be used with a wide variety of loads and signal types. The 16 circuits are divided into two groups with 8 circuits each. Each group can be supplied from a separate power source. Power to operate the field devices must also be supplied by the user. The ON/OFF status of each circuit is indicated by an LED, which is located on the logic side of the circuitry. The 16 output circuits are connected to user loads through a removable socket type terminal board. Following are specifications for each of the 16 circuits:

Outputs	16
Operating Voltage	5 to 220 V ac 5 to 30 V dc
AC Frequency	47-63 Hz
Maximum Current*	2 amps (Resistive) 8 amps per Common (maximum)
Maximum Leakage Current (Across Contacts)	0.1 mA
Smallest Recommended Load	5 mA
Maximum Inrush	2 amps
OFF to ON Response	10 ms
ON to OFF Response	10 ms
Circuit Indicator	Logic Side
Fuses (Recommended, External)	2 amp in series with load
Internal Power Consumption	30 mA for each ON Circuit @ 9 V dc
Units of Load	48 units
Weight	8.5 oz (240 g)

*Since non-solid state devices are used as the power switching devices, the following limitations must be observed for reliable operation:

Table 6-3. Maximum Current vs Load Type for Relay Outputs

OPERATING VOLTAGE	MAXIMUM CURRENT FOR LOAD TYPE			TYPICAL LIFE (OPERATIONS)
	RESISTIVE	LAMP	SOLENOID	
220 V ac	2 Amp	0.25 Amp	0.25 Amp	100,000
220 V ac		0.03 Amp	0.03 Amp	800,000
110 V ac	2 Amp	0.25 Amp	0.25 Amp	100,000
110 V ac		0.05 Amp	0.05 Amp	650,000
24 V ac	2 Amp	0.25 Amp	0.25 Amp	100,000

NOTE

Lamp loads are defined as a X10 inrush with a power factor (PF) of 1.00 and when turned OFF represent a PF of 1.00. Solenoids are defined with a X10 inrush, a PF of 0.65, and when turned OFF represent a PF of 0.35

a40806

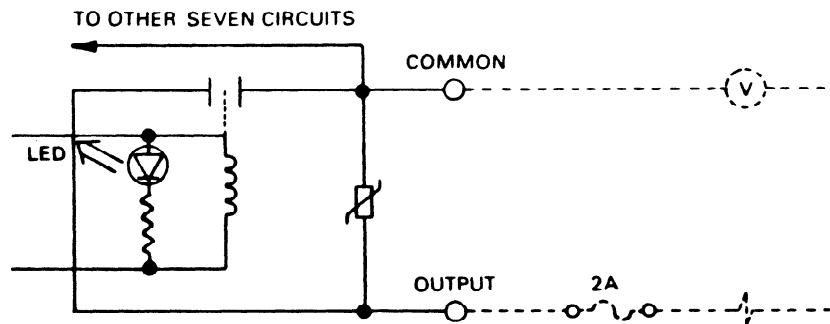
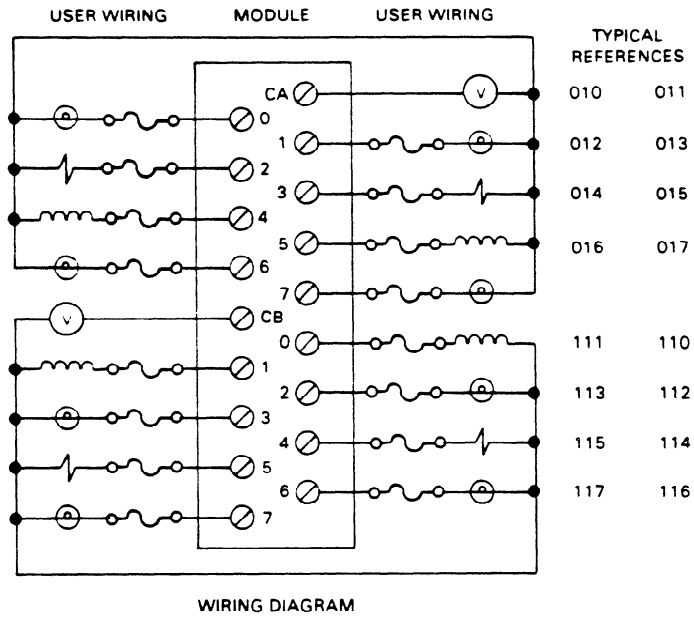

Figure 6-35. Wiring for 16 Circuit Relay Outputs

GEK-90842

**24 V dc Input/Output (4 In/4 Out)
IC610MDL103**

This module provides a dual function since it provides 4 input circuits each designed to receive a single discrete (ON/OFF) signal from user supplied devices and 4 output circuits each capable of controlling user supplied discrete (ON/OFF) loads. Typical input devices include limit switches, pushbuttons, selector switches, and relay contacts. Typical loads include relay coils, motor starters, solenoid valves, and indicator lights.

24 V dc power to sense the state of the inputs is provided by the rack power supply. The 4 output circuits are referenced, through their respective loads, to a single DC power source. The ON/OFF state of each input and output circuit is indicated by an LED. Figure 6.36 provides wiring information for this module. Following are specifications for each of the 4 input and 4 output circuits:

INPUT CIRCUITS	
Input Points	4
Maximum Voltage (Open Circuit)	36 V dc
Input Current	18 mA
ON Level	0-3 V dc
OFF Level	18-36 V dc
OFF to ON Response	4-15 ms
ON to OFF Response	4-15 ms
Maximum OFF Leakage	3 mA
Minimum ON Current	7 mA
OUTPUT CIRCUITS	
Output Points	4
Operating Voltage	5-24 V dc
Peak Voltage	45 V dc
Maximum Current	0.5 amp
Maximum Leakage Current	0.1 mA @ 40 V dc
ON Voltage Drop (Typical)	0.8 V dc @ 0.5 amp 0.65 V dc @ .1 amp
ON Voltage Drop (Max)	1.5 V dc @ 0.5 amp
OFF to ON Response	0.1 ms
ON to OFF Response	0.1 ms
Fuse (Internal)	3 amp (In Output common line)
Internal Power Consumption	20 mA @ 9 V dc
Inputs	14 mA for each On Circuit
Outputs	3 mA for each On Circuit
Units of Load	2 units @ 9 V dc
7 units @ 24 V dc	
Weight	4.6 oz (130 g)

pc-s1-83-0071

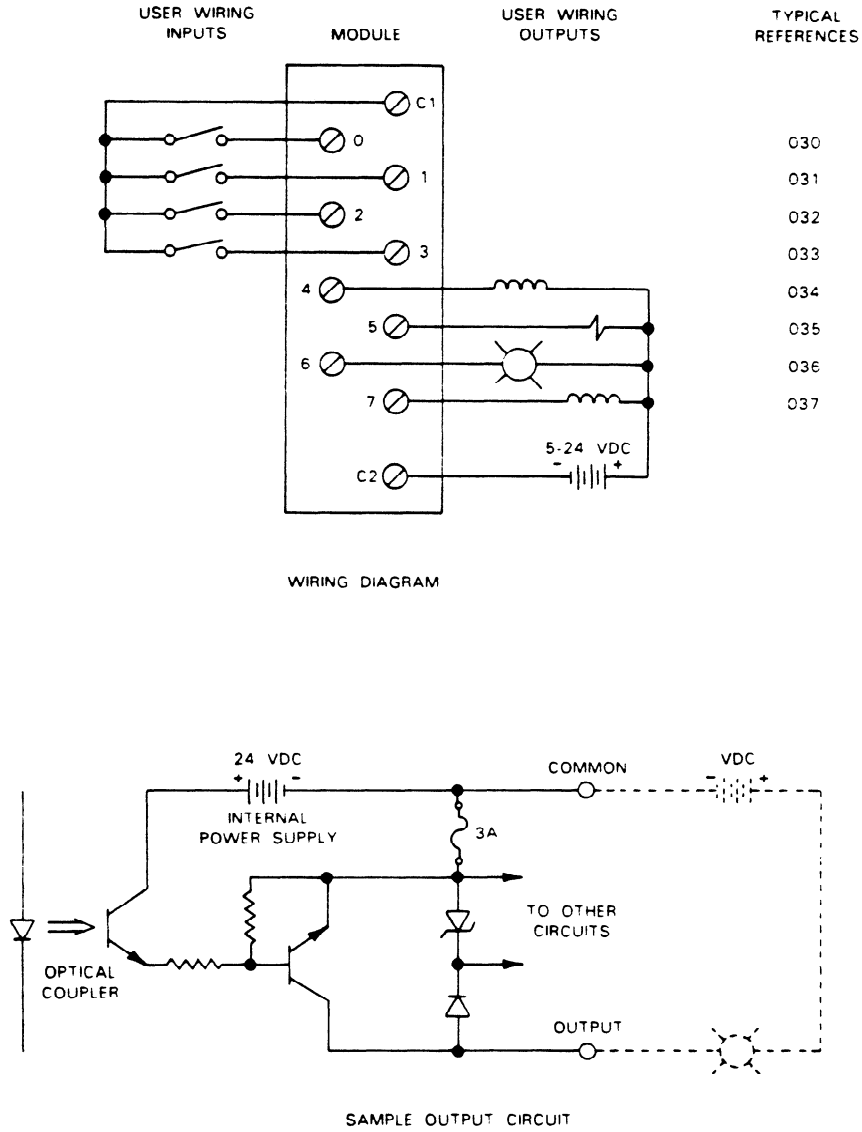

Figure 6-36. Wiring for 24 V dc Inputs/Outputs

GEK-90842

24 V dc Input/Relay Output (4 In/4 Out)
IC610MDL104

This module provides 4 dc input circuits and 4 relay output circuits. The 4 input circuits are each designed to receive a single discrete (ON/OFF) signal from user supplied devices such as limit switches, pushbuttons, and relay contacts. The 4 relay output circuits are each capable of controlling user supplied discrete (ON/OFF) loads. Typical loads include relay coils, motor starters, and indicator lights. Since the relay output circuits were not designed for a specific current type, such as 24 V dc or 115 V ac, they can be used for a wide variety of loads and signal types. The ON or OFF state of each input and output circuit is indicated by an LED. Figures 6.37 and 6.38 provide wiring information for this module. Following are specifications for each input and output circuit.

DC INPUT CIRCUITS	
Input Points	4
Maximum Voltage	36 V dc
Input Current	18 mA (max)
ON Level	0-3 V dc
OFF Level	18-36 V dc
OFF to ON Response	4-15 ms
ON to OFF Response	4-15 ms
Maximum OFF Leakage	3 mA
Minimum ON Current	7 mA
RELAY OUTPUT CIRCUITS	
Outputs	4
Operating Voltage	5 to 265 V ac/dc
AC Frequency	47-63 Hz
Maximum Current*	4 amp (resistive)
Maximum Leakage Current (Across Contacts)	1 mA
Smallest Recommended Load	5 mA
Maximum Inrush	5 amps
OFF to ON Response	5 ms
ON to OFF Response	5 ms
Circuit Indicator	Logic Side
Fuse (In Output Common Line, Replaceable)	10 amp
Internal Power Consumption	45 mA for each ON Circuit @ 9 V dc
Units of Load	20 units @ 9 V dc
6 units @ 24 V dc	

*Since non-solid state devices are used as the power switching devices, the limitations listed in table 6-4 must be observed for reliable operation:

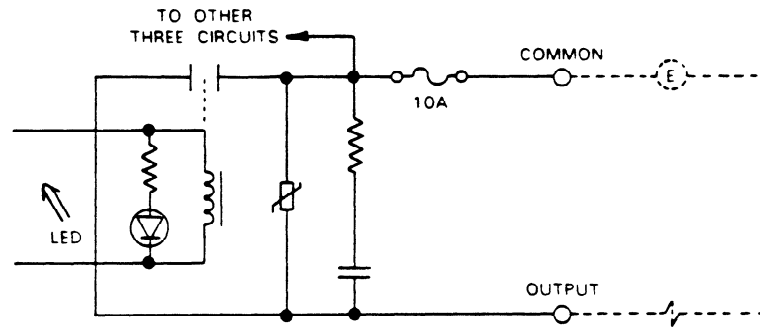

SAMPLE RELAY OUTPUT CIRCUIT

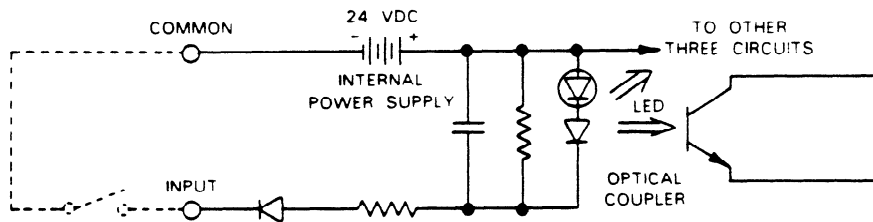

SAMPLE INPUT CIRCUIT

Figure 6-38. Sample 24 V dc INPUT/RELAY OUTPUT Circuits

Thumbwheel Interface IC610MDL105

This module provides an interface between the Series One or Series One Plus PCs and up to four sets of user supplied thumbwheels. Each set of thumbwheels will allow the operator to control the preset on a timer or counter. In fact, these timer/counters (references 674 to 677) will not function without this interface module. The power (24 V dc) to sense the state of these thumbwheels is provided by the power supply in the CPU base unit. This interface module must be installed in the same base unit as the CPU and can only be located in slots 2 through 5. Only one interface module is allowed per system. The thumbwheels and their associated wiring must be supplied by the user. The thumbwheels are standard BCD coded and diode isolated, a standard option available with most thumbwheels. The following is the required setting for each digit of the thumbwheel:

Digit Value	Internal	Switch	Closure	(X=Closed)
	8	4	2	1
0				
1				X
2			X	
3			X	X
4		X		
5		X		X
6		X	X	
7		X	X	X
8	X			
9	X			X

Whenever the interface is installed in the CPU base unit, eight discrete references are assigned to this module slot. These references have no significance relative to the operation of the interface. They can be used as internal coils, but not as status to other hardware I/O. All four presets are read into the Series One or Series One Plus PC each scan. Figure 6.39 illustrates the wiring for the 20 terminals on the interface module. No special terminations are required for circuits that are not being used.

One thumbwheel is read into the CPU every scan assuring rapid response to new values. Care should be used when changing the value on the thumbwheels, since intermediate values can be brought in and used during a scan or for several scans. For example, if the thumbwheel is set for the value 095 and the new value 105 is desired, altering the hundreds digit first results in 195 being detected and used by the CPU, until the tens digit is changed from 9 to 0. Normally, higher values are more acceptable than lower values and the natural tendency to enter new values from the left or high order digit will result in larger values. However, if the tens digit is changed first, the value 005 could be read prior to the 105 being set. The exact results depend upon the application and the specific logic entered.

Internal Power Consumption

90 mA @ 24 V dc (9 units of load)
10 mA @ 9 V dc (1 unit of load)

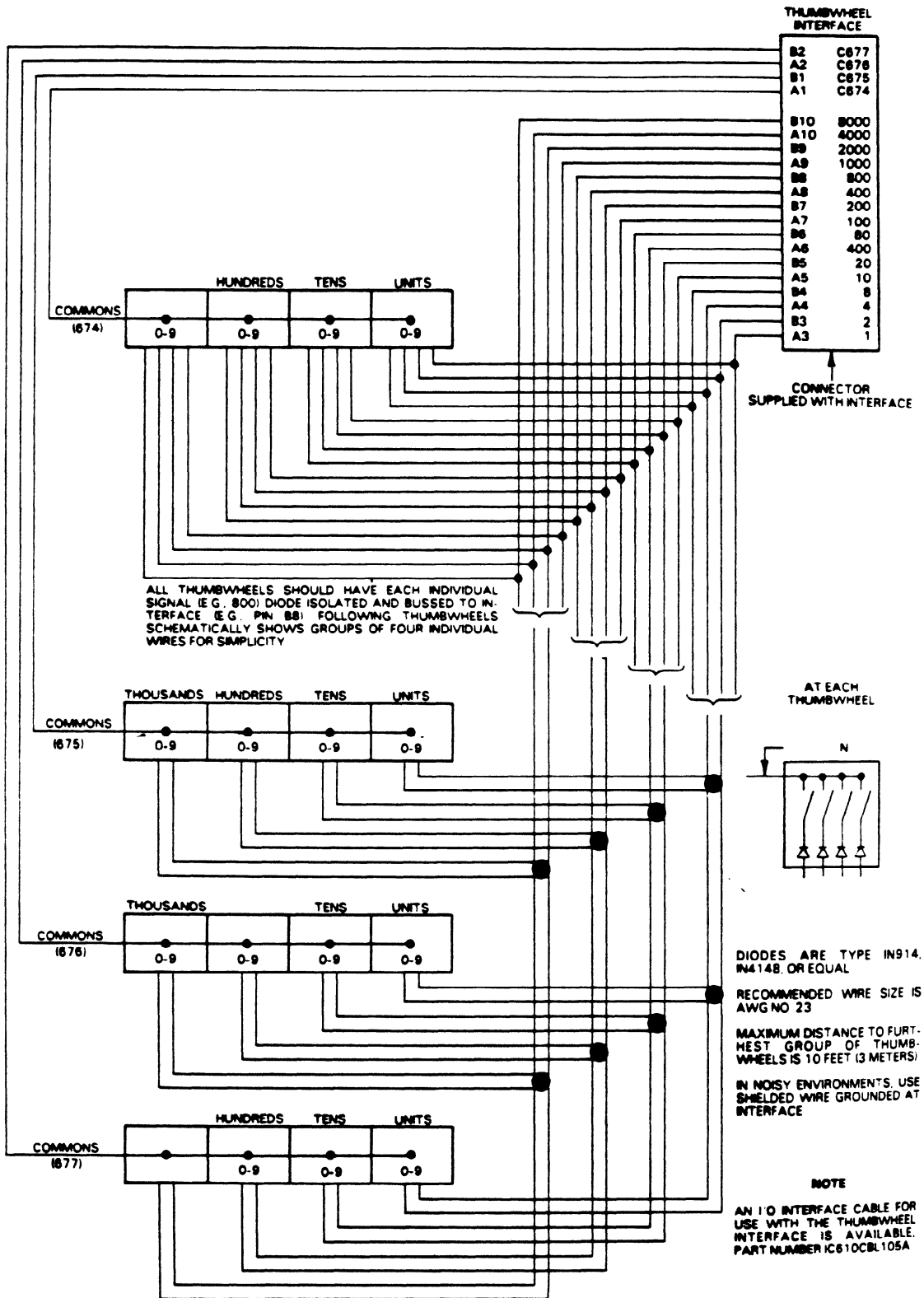

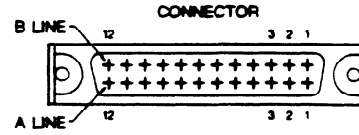

Figure 6-39. Wiring for Thumbwheel Interface

pc-s1-83-0067

 **GEJ-7000**
Thumbwheel Interface Cable
Wire List and Installation Diagram



Pin No	Signal	Wire color code
A1	674 Thumbwheel switch common	ORN (RED1)
A2	676 Thumbwheel switch common	GRA (RED1)
A3	units digit	1 WHT (RED1)
A4		4 YEL (RED1)
A5	tens digit	1 PNK (RED1)
A6		4 ORN (RED2)
A7	hundreds digit	1 GRA (RED2)
A8		4 WHT (RED2)
A9	thousands digit	1 YEL (RED2)
A10		4 PNK (RED2)
A11	not connected*	ORN (RED3)
A12	not connected*	GRA (RED3)

Pin No.	Signal	Wire color code
B1	675 Thumbwheel switch common	ORN (BLK1)
B2	677 Thumbwheel switch common	GRA (BLK1)
B3	units digit	2 WHT (BLK1)
B4		8 YEL (BLK1)
B5	tens digit	2 PNK (BLK1)
B6		8 ORN (BLK2)
B7	hundreds digit	2 GRA (BLK2)
B8		8 WHT (BLK2)
B9	thousands digit	2 YEL (BLK2)
B10		8 PNK (BLK2)
B11	not connected*	ORN (BLK3)
B12	not connected*	GRA (BLK3)

Color Code Example

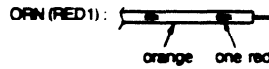

ORNorange
GRAgray
WHTwhite
YELyellow
PNKpink
REDred
BLKblack

The white wire with three red marks and the white wire with three black marks are not used.

* If solid state BCD input is used, connect to BCD input device common.

Figure 6-40. Thumbwheel Interface Cable Wire List

GEK-90842

**High Speed Counter
IC610MDL110**

The High Speed Counter module (HSC) allows a Series One or Series One Plus PC to monitor and control a number of process variables (position, velocity, flow rate) that the CPU cannot control due to timing constraints. A logical relationship between the counters seven inputs, the preset, and current value determines the status of its own two external outputs as well as others through CPU user logic. Figure 6.41 illustrates this concept.

The module can be installed in any of the first 4 I/O slots adjacent to the CPU, and uses 8 I/O and 2 counter references to interface with user logic. Indicators on the front face of the module give output and count status.

General Specifications	
Up/Down Counter Inputs	Increment (Up) Count Decrement (Down) Count Reset/Marker Preset Value (0 - 9999) Current Value (0 - 9999)
Up/Down Counter Outputs	Two Discrete DC (5 - 24 V) Current Value (BCD)
Reaction Time	< 100 Microseconds Between Pulse Received and Transition of Output
Environmental	
Operating Temperature	0 to 60° C
Humidity, Non-Condensing	5 to 95 %
Power Consumption from Internal Supply	70 mA @ 9 V dc
Pulse Rate	Without Filter < 10 kHz With Filter < 500 Hz (Filter selection by three dip switches on module, see page 6-69)
Range	0 to 9999 Binary Coded Decimal(BCD)
Minimum Pulse Width	25 mS

a00807

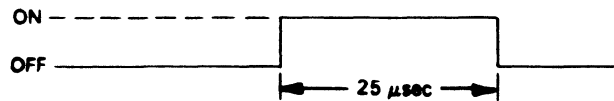

GEK-90842

Module Location

The High Speed counter module (HSC) can be installed in any one of the four I/O slots adjacent to the CPU slot in the CPU chassis. In figure 6.42, these slots are shown (A, B, C and D) for a 5-slot rack. In a 10-slot rack, the HSC must also occupy 1 of the 4 slots adjacent to the CPU. Also shown in this figure are the I/O references used by the HSC to interface with user logic. Note how an HSC located in Slot A uses I/O references associated with both Slot A (0-3) and Slot A' (100-103).

Since each slot in a Series One or Series One Plus PC I/O system corresponds to a special group of eight I/O references, an HSC in Slot A eliminates Slot A' from the I/O system. Likewise an HSC located in Slot B eliminates Slot B' from the I/O system. In summary, an HSC physically occupies one I/O slot, but requires two slots worth of I/O references to interface with user logic (Refer to table 6.5).

pc-s1-84-0001

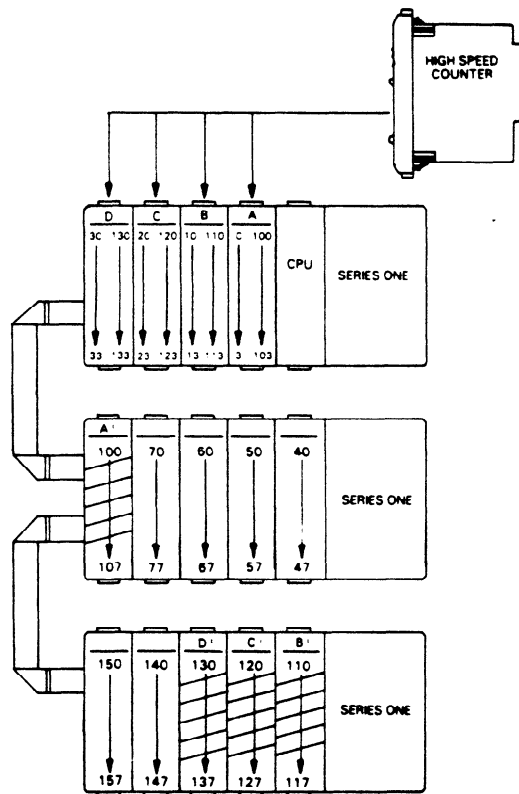

Figure 6-42. HSC Location in 5-Slot Rack

Table 6-5. Number of HSCs vs Discrete I/O Capacity

NUMBER OF HIGH SPEED COUNTER MODULES IN SYSTEM	REMAINING DISCRETE I/O CAPACITY	
	Series One	Series One Plus
0	112	168
1	96	152
2	80	136
3	64	120
4	48	104

Interface to Field Devices

A 32 PIN Connector (Refer to figure 6.43) on the faceplate of the HSC is the interface between the module and its associated field devices which include:

1. Counting mechanism which controls the Up/Down counter (typically a bi-directional incremental encoder).
2. Four digit binary coded decimal (BCD) display of counters current value.
3. Two 5 to -24 V dc loads under control of two counter outputs.

pc-s1-84-0003

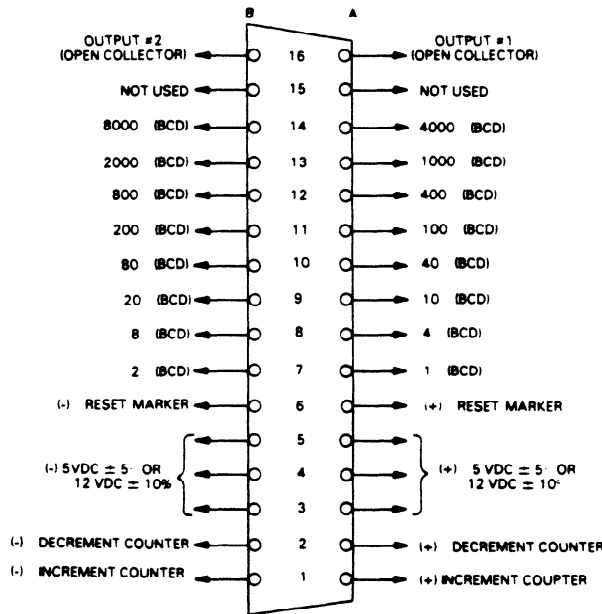

Figure 6-43. HSC Connector Pin Definition

In the interest of clarity the specifications for each field device are addressed separately.

GEK-90842

Up/Down Counter Inputs

SPECIFICATIONS		
ITEM	UP/DOWN INPUT	RESET INPUT
Minimum Input Pulse Width	25 nSec	100 nSec
Supply Voltage	+12 V dc, 10%	+12 V dc, 10%
On Current	< 3 mA	10 to 15 mA
Off Current	10 to 15 mA	< 3 mA
On Voltage	< 3 V dc	> 7 V dc
Off Voltage	> 7 V dc	< 3 V dc

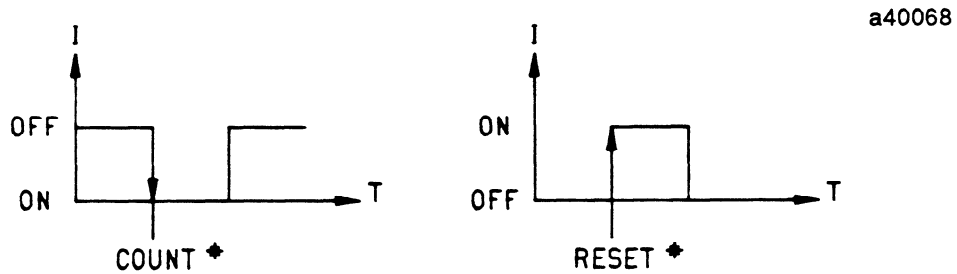

Figure 6-44. Signal Direction

The conditions necessary to increment/decrement, or reset the counter are described below. This is of particular interest when counting in one direction only.

DESIRED ACTION	CONDITION
Increment Current Count	Increment Input: (Disabled) -- (Enabled) Decrement Input: Disabled Reset Input: Disabled
Decrement Current Count	Decrement Input: (Disabled) -- (Enabled) Increment Input: Disabled Reset Input: Disabled
Reset Current Count	Reset Input: (Disabled) -- (Enabled) Increment Input: Disabled or Enabled Decrement Input: Disabled or Enabled
Increment Input:	Disabled, > 10 V dc Between Pins B1 and A1 Enabled, < 2 V dc Between Pins B1 and A1
Decrement Input:	Disabled, > 10 V dc Between Pins B2 and A2 Enabled, < 2 V dc Between Pins B2 and A2
Reset Input:	Disabled, < 2 V dc Between Pins B6 and A6 Enabled, > 10 V dc Between Pins B6 and A6

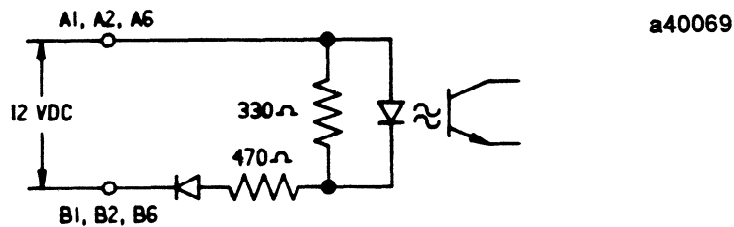

Figure 6-45. UP/DOWN/RESET Input Circuit

Encoder Interface 1

Typically an incremental encoder controls the counter through the Up/Down, and Reset Inputs. To comply with HSC circuitry, the encoder should represent clockwise and counterclockwise movement of its shaft with two separate pulse trains that increment and decrement the counter. Figures 6.46, 6.47, and 6.48 illustrate sample connections.

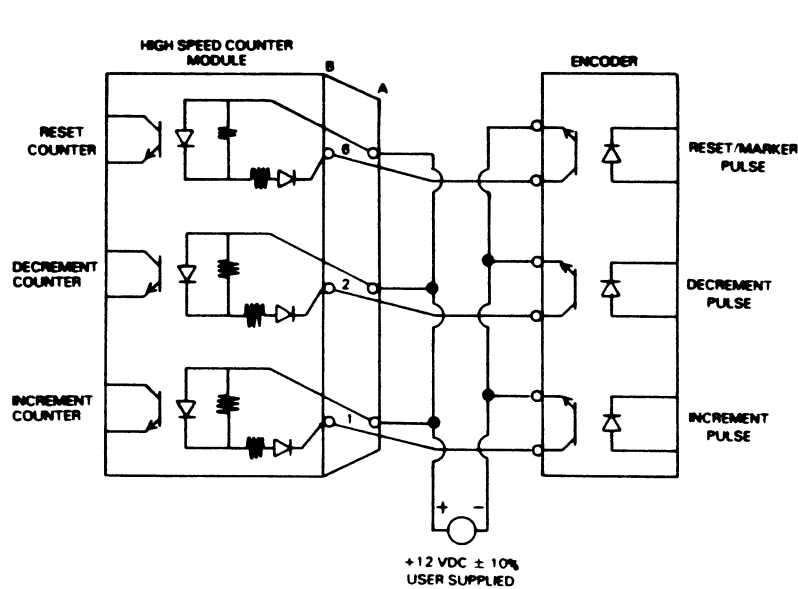

Figure 6-46. Encoder with RESET/MARKER Option Resetting Counter Once per Revolution of Encoder Shaft

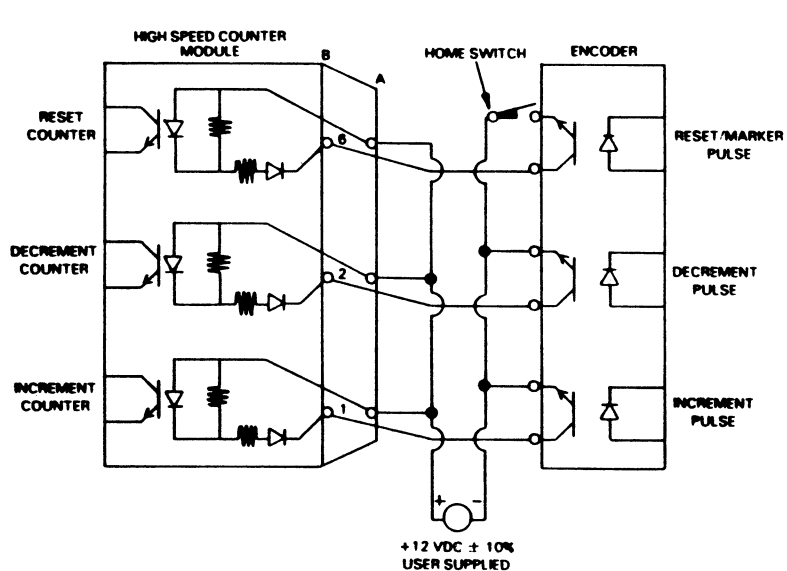

Figure 6-47. Encoder with RESET Option in Series with Home Limit Switch Such That Counter is Reset When Both Home Limit Switch and RESET/MARKER Pulse are Enabled

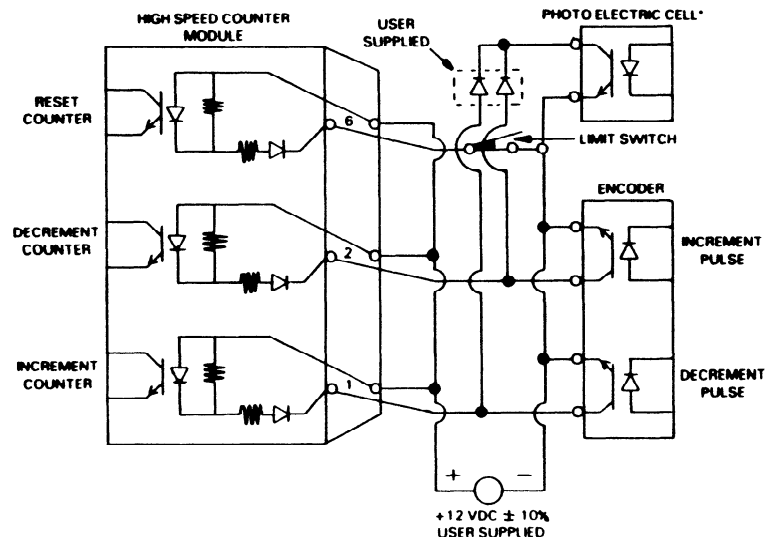

Figure 6-48. Encoder With Limit Switch Resetting Counter and Photoelectric Cell Inhibiting the Counter Operation

GEK-90842

Figure 6.50 illustrates the connections necessary to use an external BCD Display. For a source type output the 5 V or 12 V supply is required.

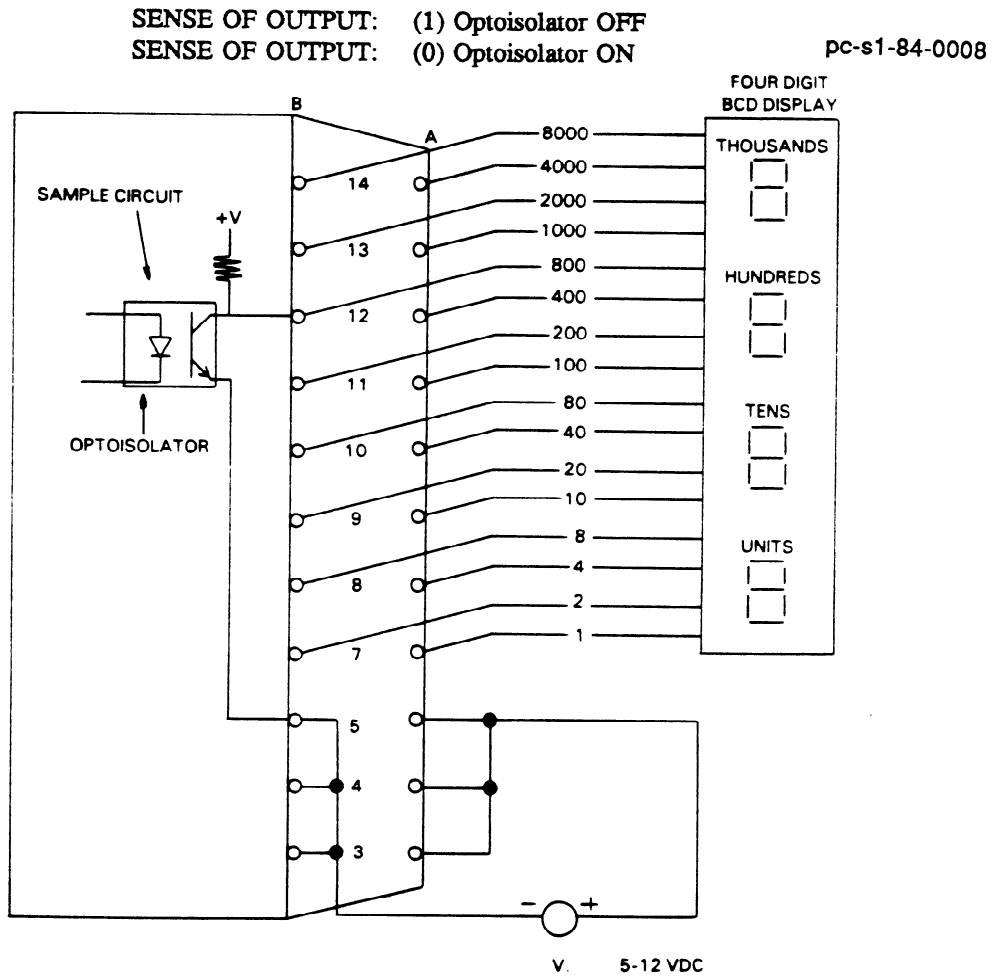

Figure 6-50. BCD Output Wiring Diagram

Counter Output

The HSC has two discrete outputs that can be controlled from ladder logic or by the relationship (\geq or \leq) between the present and current value of the counter.

SPECIFICATIONS	
ITEM	RATING
Type	NPN Transistor, open collector, sinking
Voltage Range	5 to 24 V dc
Peak Voltage	< 45 V dc
Current Range	> 0.3 A

A typical wiring schematic to field devices and a sample circuit are shown in figure 6.51.

pc-s1-84-0009

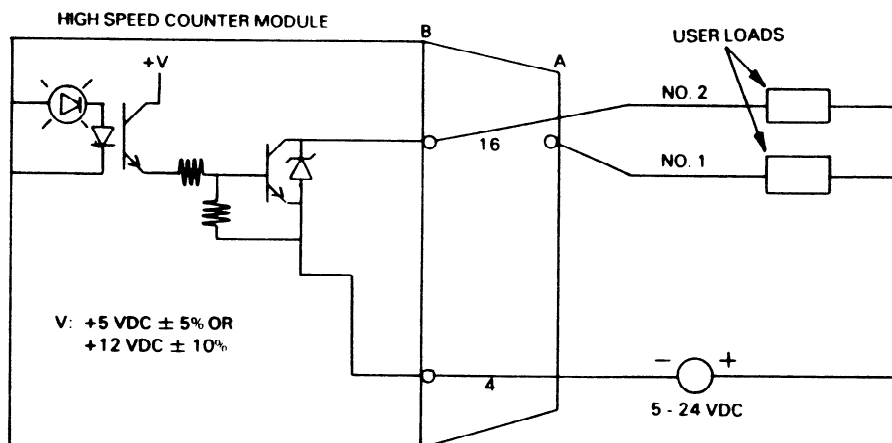

Figure 6-51. User Load Wiring Diagram

GEK-90842

Interface to User Logic

Eight I/O and two counter functions interface the HSC to user logic. The specific references associated with these functions depend upon the location of the module in the CPU rack. Figure 6.52 illustrates how these references correspond to the modules location.

pc-s1-84-0011

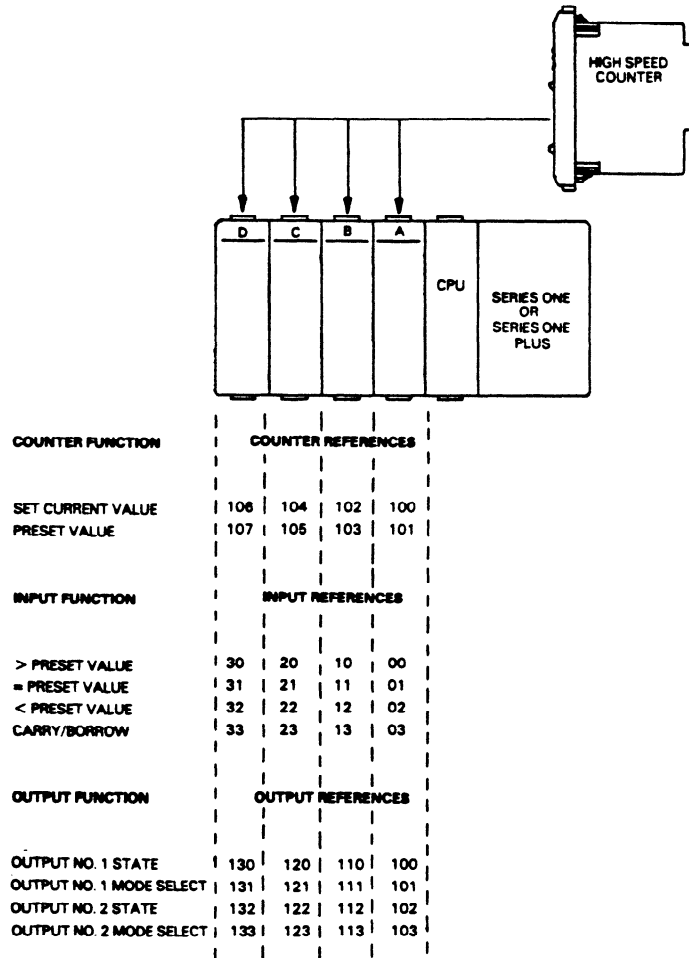

Figure 6-52. I/O and Counter Function Reference Chart

Interface Function Definition

Shown below is the definition and user logic symbol for each interface function.

a42645

COUNTER FUNCTIONS

SET CURRENT VALUE

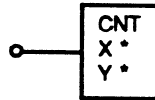
USER LOGIC SYMBOL

X: 100, 102, 104, 106
Y: 0 - 9999

DEFINITION

WHEN COUNTER X IS ENABLED,
CURRENT COUNT IS SET TO A
VALUE OF Y

PRESET VALUE

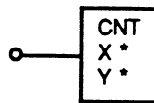

X: 101, 103, 105, 107
Y: 0 - 9999

WHEN COUNTER X IS ENABLED,
PRESET VALUE OF COUNTER
IS SET TO Y

- * X = Counter Reference
- * Y = Valid Range

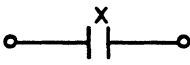
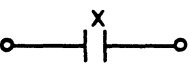
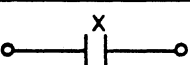
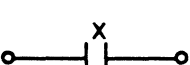
INPUT FUNCTIONS	USER LOGIC SYMBOL	DEFINITION
> PRESET VALUE* *	 <p data-bbox="682 470 855 495">X: 00, 10, 20, 30</p>	ENABLED WHEN CURRENT VALUE OF COUNTER IS GREATER THAN ITS PRESET VALUE
= PRESET VALUE* *	 <p data-bbox="682 608 855 634">X: 01, 11, 21, 31</p>	ENABLED WHEN CURRENT VALUE OF COUNTER IS EQUAL TO ITS PRESET VALUE
< PRESET VALUE* *	 <p data-bbox="682 742 855 768">X: 02, 12, 22, 32</p>	ENABLED WHEN CURRENT VALUE OF COUNTER IS LESS THAN ITS PRESET VALUE
CARRY / BORROW	 <p data-bbox="682 880 855 906">X: 03, 13, 23, 33</p>	*

* Enabled when current value of the counter undergoes one of the six sequences described below :

1. 0001 - 0000 - 9999 (Decrement Rollover)
2. 9999 - 0000 - 0001 (Increment Rollover)
3. 0001 - 0000 - 0001
4. 9998 - 9999 - 9998
5. (Increment Current Count) - (Externally Reset Counter) - (Decrement Current Count)
6. (Decrement Current Count) - (Externally Reset Counter) - (Increment or Decrement Current Count)

* * The status of these input functions is given to the CPU once per scan. Therefore, if a particular condition is true for less than the scan time of the user logic, its associated input function would not be enabled in the user program.

a42647

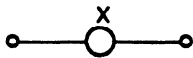
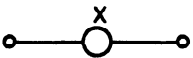
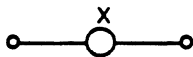
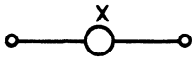
<u>OUTPUT FUNCTIONS</u>	<u>USER LOGIC SYMBOL</u>	<u>DEFINITION *</u>
OUTPUT NO. 1 MODE SELECT	 <p>X: 101, 111, 121, 131</p>	<ul style="list-style-type: none"> • IF DISABLED OUTPUT NO. 1 IS IN MANUAL MODE • IF ENABLED OUTPUT NO. 1 IS IN COUNTER MODE
OUTPUT NO. 1 STATE	 <p>X: 100, 110, 120, 130</p>	<ul style="list-style-type: none"> • IN MANUAL MODE OPERATES OUTPUT NO. 1 AS NORMAL OUTPUT • IN COUNTER MODE DETERMINES IF OUTPUT NO. 1 IS ENABLED BEFORE OR AFTER PRESET IS REACHED
OUTPUT NO. 2 MODE SELECT	 <p>X: 103, 113, 123, 133</p>	<ul style="list-style-type: none"> • IF DISABLED OUTPUT NO. 2 IS IN MANUAL MODE • IF ENABLED OUTPUT NO. 2 IS IN COUNTER MODE.
OUTPUT NO. 2 STATE	 <p>X: 102, 112, 122, 132</p>	<ul style="list-style-type: none"> • IN MANUAL MODE OPERATES OUTPUT NO. 2 AS NORMAL OUTPUT • IN COUNTER MODE DETERMINES IF OUTPUT NO. 2 IS ENABLED BEFORE OR AFTER PRESET IS REACHED

* For further description on the operation of outputs, refer to Output Logic Section.

GEK-90842

Output Logic

Each of the two HSC outputs operate in either the manual or counter mode. The operating mode of each output is determined by the state of its mode select function (refer to output function section). The logic of each mode will be covered separately.

If Mode Select Function Disabled (0): Manual Mode, Enabled (1): Counter Mode.

Manual Mode

The state of an output in the manual mode corresponds to the status of its associated Output State Function as shown below in the manual mode output truth table.

Table 6-6. Manual Mode Output Logic Truth Table

OUTPUT MODE SELECT	OUTPUT STATE	OUTPUT
0	0	0
0	1	1

Counter Mode

In the counter mode of operation outputs can react immediately when the current count reaches specific preset values. In this mode each output is controlled by a combination of three factors.

1. Initial relationship between preset and current count.
2. Real time relationship between preset and current count.
3. Status of Output State function.

When the HSC receives a preset value from user logic (via preset counter function), it is initially compared to the current value of the counter. If the preset is greater than the current count in this initial comparison the real time comparison*²between the preset and current count is "true" when the current count is greater than or equal to the preset. In other words when the current count reaches the preset moving in the POSITIVE direction the real time comparison becomes "true". This concept is shown below in table 6.7.

Table 6-7. Real Time Comparison Table for Preset Initially > Current Count

	CURRENT COUNT < PRESET	CURRENT COUNT ≥ PRESET
REAL TIME COMPARISON STATUS	FALSE	TRUE

*Real Time Comparison = continuous comparison between preset value and current value of counter.

Conversely, if the preset is initially less than the current count, the real time comparison is “true” when the current count is less than or equal to the preset. In other words, when the current count reaches the preset moving in the negative direction the real time comparison becomes “true”. This concept is shown below in table 6.8.

Table 6-8. Real Time Comparison Table for Preset Initially < Current Count

	CURRENT COUNT > PRESET	CURRENT COUNT < PRESET
REAL TIME COMPARISON STATUS	FALSE	TRUE

Once the status of the real time comparison between the preset and current count has been determined, the status of the output is easily obtained. If the outputs associated output state function is disabled its status corresponds directly to the real time comparison status. If the output state function is enabled the output’s status is the inverse of the real time comparison status. This concept is shown in table 6.9.

Table 6-9. Output State vs Real Time Comparison Status in Counter Mode

OUTPUT STATE FUNCTION	REAL TIME COMPARISON IS FALSE	REAL TIME COMPARISON IS TRUE
DISABLED	0	1
ENABLED	1	0
1: OUTPUT ENABLED 0: OUTPUT DISABLED		

Table 6.10 summarizes the logic associated with an output in the counter mode of operation.

GEK-90842

Table 6-10. Output Logic in Counter Mode

INITIALLY PRESET > CURRENT COUNT		
OUTPUT STATE FUNCTION	CURRENT COUNT < PRESET	CURRENT COUNT ≥ PRESET
0	0	1
1	1	0
INITIALLY PRESET < CURRENT COUNT		
OUTPUT STATE FUNCTION	CURRENT COUNT > PRESET	CURRENT COUNT < PRESET
0	0	1
1	1	0

Filter Selection

In some electrical noisy environments it may be necessary to filter out noise through filters available on the module. The HSC provides this capability on the incremental count, decremental count, and reset/marker inputs. The location of these switches on the module is shown in figure 6.53.

Sense of switch: OPEN - Filter Disabled (< 10 Khz)
 CLOSED - Filter Enabled (< 500 Hz)

pc-s1-84-0004

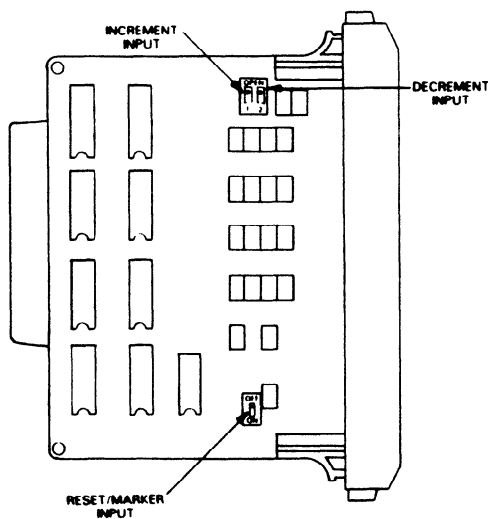

Figure 6-53. Filter Selection with Dip Switch

Fast Response I/O IC610MDL115

The Fast Response I/O module allows a Series One or Series One Plus PC to respond quickly to an input and/or monitor very short input pulses. The module's four 24 V dc inputs and two relay outputs use 8 I/O references to interface with user logic. Each of the 2 outputs can operate in a manual or fast response mode. An output in manual mode is controlled from user logic similar to any other discrete output. An output in the fast response mode can be controlled independent of CPU scan time by its 2 associated inputs, with one input enabling it, and the other disabling it. Up to 14 Fast Response I/O modules can be included in a Series One or Series One Plus PC system, thereby providing 28 fast response outputs and 56 inputs total. Following are specifications for each of the input and output circuits.

DC INPUT CIRCUITS	
Number of Circuits	4
Maximum Voltage (Open Circuit)	36 V dc
Input Current	16 mA (maximum)
ON Level	0 - 3 V dc
OFF Level	18 - 36 V dc
OFF to ON Response	0.3 to 1 ms
ON to OFF Response	50 to 150 ms
Maximum OFF Current	3 mA
Minimum ON Current	7 mA
Input Pulse Width	1 ms (minimum)
Circuit Indicator	Field Side

NOTE

Input Switching Voltage Provided by Module

RELAY OUTPUT CIRCUITS	
Number of Circuits	2
Operating Voltage	5-265 V ac/dc
Ac Frequency Range	47-63 Hz
Maximum Current*	4 amp (resistive) 0.5 amp (inductive)
Maximum Leakage Current	1 mA
Smallest Recommended Load	10 mA
Maximum Inrush	5 amps
OFF To ON Response	5 ms (maximum)
ON To OFF Response	5 to 10 ms
Circuit Indicator	Field Side
Circuit Indicator	Field Side
Fuse (In Output Common Line)	3 amp
Internal Power Consumption	50 mA + 53 mA/Output ON Circuit at 9 V dc, 15 mA/Input @ 24 V dc Units of Load: 16 (9 V dc) 6 (24 V dc)

Since non-solid state relays are used as the power switching devices, the limitations as shown in table below must be observed for reliable operation.

GEK-90842

Table 6-11. Maximum Current vs. Load Type for Relay Outputs

OPERATING VOLTAGE	MAXIMUM CURRENT FOR LOAD TYPE			TYPICAL LIFE (OPERATIONS)
	RESISTIVE	LAMP	SOLENOID	
220 V ac	4 Amp	0.5 Amp	0.5 Amp	100,000
220 V ac		0.05 Amp	0.05 Amp	800,000
110 V ac	4 Amp	0.5 Amp	0.5 Amp	150,000
110 V ac		0.1 Amp	0.1 Amp	650,000
24 V dc	5 Amp	0.5 Amp	0.5 Amp	100,000
50 V dc	1 Amp	0.1 Amp	0.1 Amp	100,000
100 V dc	0.5 Amp	0.05 Amp	0.05 Amp	100,000
250 V dc	0.3 Amp	0.03 Amp	0.03 Amp	100,000

NOTE

Lamp loads are defined as a X10 inrush with a power factor (PF) of 1.00 and when turned OFF represent a PF of 1.00. Solenoids are defined with a X10 inrush, a PF of 0.65, and when turned OFF represent a PF of 0.35.

b40556

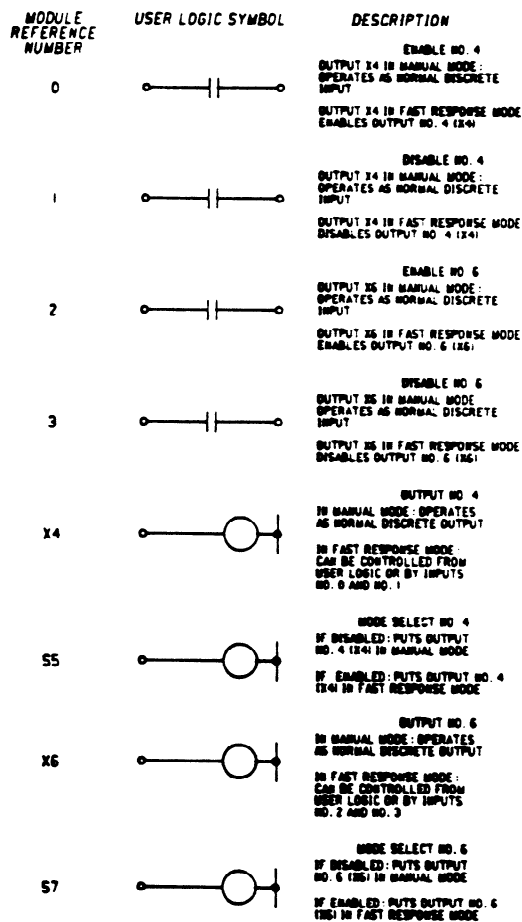

Figure 6-54. Module Reference NUMBER/LOGIC Symbol Definition

Mode Selection

The Operating Mode Selection of outputs X4 and X6 is determined by the status of their mode select references S5 and S7 as shown in table 6.12.

Table 6-12. Operating Mode Selection

MODE SELECT	OUTPUT
(S5 and S7) Disabled (0) Enabled (1)	(X4 and X6) Manual Mode Fast Response Mode

Output Logic - Manual Mode

An output operating in the manual mode is controlled through user logic similar to any other discrete output. Its associated inputs on the fast response module do not affect it any way.

Output Logic - Fast Response Mode

In the fast response mode of operation, a combination of three factors determines the status of the output.

- State of Associated Enable Input (Reference number 0 or 2)
- State of Associated Disable Input (Reference number 1 or 3)
- User Logic

The truth table (following) shows how the output can be controlled from user logic or with its enable and disable inputs.

**Table 6-13. Truth Table for Output in Fast Response Mode
(S5 or S7 Have Been Enabled)**

ENABLE INPUT No. 0 or 2	DISABLE INPUT No. 1 or 3	USER LOGIC X4 or X6	OUTPUT
1	0	0	1
0	0	1	1
1	0	1	1
1	1	1	0
1	1	0	0
0	1	0	0
0	0	0	0

0: Disabled 1: Enabled

It can be seen from the first three rows in the truth table that the output can be enabled from its enable input or from user logic. The last four rows of this truth table show the various conditions that disable the outputs.

The logic diagram shown below in figure 6.55 summarizes the operation of this module.

a40547

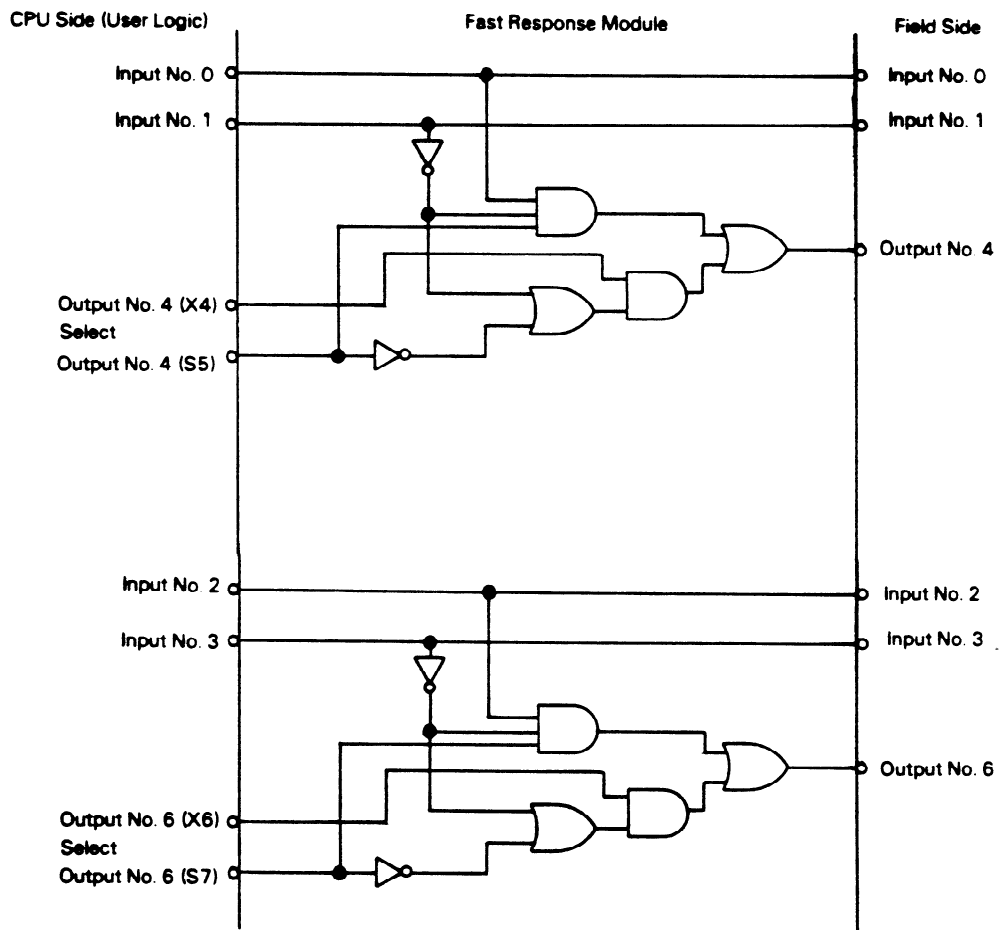
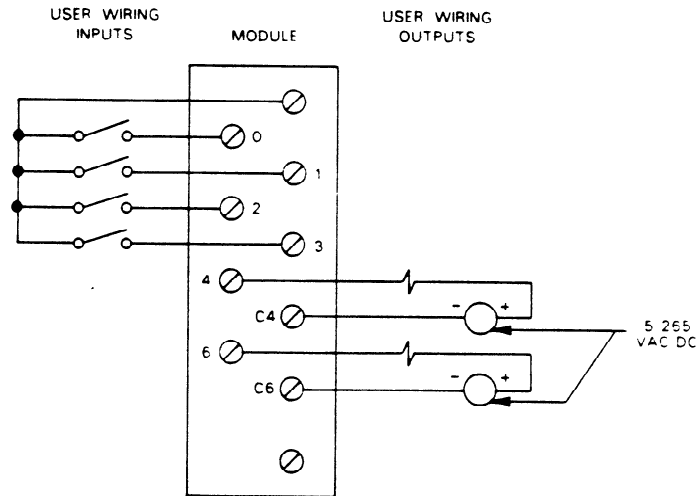

Figure 6-55. Fast Response Module Logic Diagram

pc-s1-84-0020



USER WIRING DIAGRAM

pc-s1-84-0016

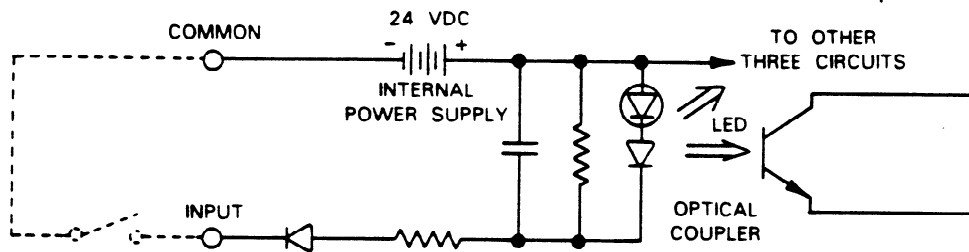

pc-s1-84-0015

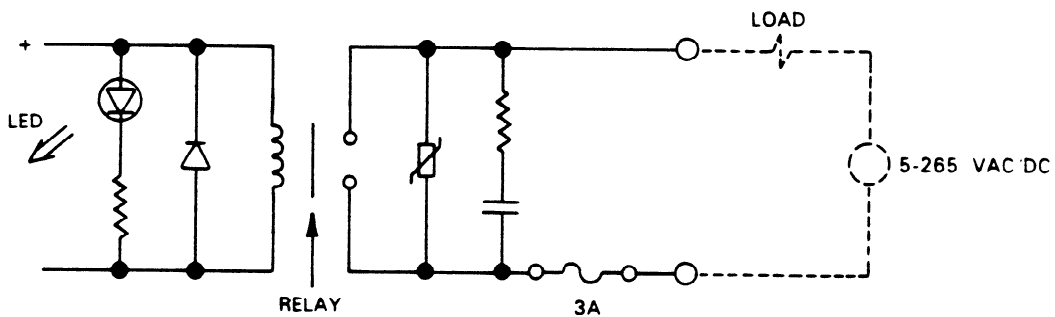

SAMPLE OUTPUT CIRCUIT

Figure 6-56. Wiring for Fast Response I/O Module

GEK-90842

**I/O Simulator
IC610MDL124**

The I/O simulator module has 8 two-position (ON or OFF) switches, each having an associated LED, that is, if switch 1 is turned ON, LED 1 will light. An I/O simulator module uses one I/O slot and the 8 I/O references assigned to that slot. Each of the switches can be programmed as a discrete input device. This module requires no field connections since its function is controlled by programming. An I/O simulator module is a valuable tool in program development and troubleshooting. An I/O simulator module could also be programmed to be used as conditional input contacts for control of output devices. Specifications for this module are as follows:

ON to OFF Response	4 to 15 ms
OFF to ON Response	4 to 15 ms
Internal Power Consumption	10 mA @ 9 V dc 14 mA/Circuit ON @ 24 V dc
Units of Load	1 unit @ 9 V dc 11 units @ 24 V dc
Weight	3.2 oz (90 g)

a40215

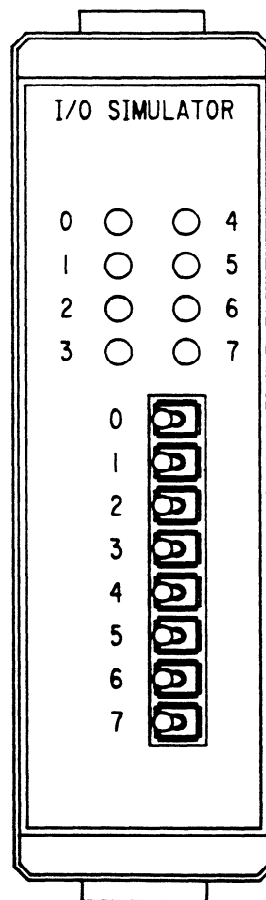

Figure 6-57. I/O Simulator Module Faceplate

Analog Input IC610MDL116

Introduction

The Analog Input module provides four independent input channels capable of converting an analog input signal to a digital signal for processing by the programmable controller. This module can be used with Series One and Series One Plus programmable controllers. However, the input can only be provided in binary form with a Series One PC. The Series One Plus, in addition to the basic functions, provides data operations (including math functions), which allows other types of operations to be performed when using the analog input module. Each Analog Input module requires 16 I/O references for addressing.

Hardware Features

The user can select, by jumper placement, to use either voltage inputs (1 to 5 V dc) or current inputs (4 to 20 mA). The factory setting is for voltage input operation. Resolution is 8 bits, which allows a maximum digital value of 255 to be converted. Eight LEDs on the faceplate provide an 8-bit binary display of the input. The channel to be displayed is selected by depressing a pushbutton on the faceplate. Each time the pushbutton is depressed, the next channel in sequence is selected, i.e., channel 1, 2, 3, 4, 1, etc.

User field wiring is made to a removable terminal board on the module's faceplate. A hinged plastic terminal cover on the terminal board protects the terminals. The terminal cover has a removable label that can be used to record circuit information.

The maximum conversion time is 2 milliseconds and does not add to the scan time of the CPU. The four channels are converted one at a time, with one channel being converted each scan. Each successive scan converts the next channel in turn.

Power Requirements

This module requires an external 24 V dc power supply. The 24 V dc supply in Series One racks can be used, however the current provided by the rack is limited to 100 mA, which is sufficient current for one Analog Input module, since the module requires up to 65 mA for operation.

General and Electrical Specifications

Specifications for this module are provided in the following table.

GEK-90842

Table 6-14. Analog Input Module Specifications

Number of Channels	4 (Independent)
Input Ranges	+1 to +5 V dc or 4 to 20 mA (jumper selectable for each channel)
Resolution	8-bit binary (1 in 256)
Digital Outputs	8 bits, binary data output 4 bits, channel status
I/O Points Required	16 consecutive (per slot assignments for 16 points, 0 to 7 and 100 to 117, etc.)
LED Display (16 LEDs)	8 bits: Data being read into the selected channel 4 bits: Channel selected for Data Display 4 bits: Channels being scanned
Operating Temperature	0 to 60° C (32 to 140° F)
Relative Humidity	5% to 95% (non-condensing)
Input Types	Differential
Input Impedance	> 1 MΩ (Voltage put) 250 Ω (Current put)
Absolute Maximum ratings	Voltage Input, 0 to +10 V dc Current Input, 0 to 30 mA
Conversion Method	Successive Approximation Method
Conversion Time	2 msec, maximum
Linearity Error	±0.8%, maximum
Accuracy	±1% at 25° C, maximum
Accuracy vs. Temperature	±50 ppm (parts per million) per 1°C
External Power Source	+25 V dc, 65 mA (maximum)
9 V dc Power Consumption	55 mA (Supplied by rack power supply)

I/O Reference Definitions

The Analog Input module uses 16 consecutive I/O points, beginning with the first I/O reference assigned to the I/O slot selected for the module. In the table, it is assumed that the Analog Input module is placed in slot 3 of a properly configured 5 or 10-slot CPU rack (references 10 to 17 and 110 to 117). These references are used for the example only, other valid references for I/O slots that allow 16 references can be used. The following table defines the use of each of the I/O points.

Table 6-15. I/O Point Definition

I/O POINT	DEFINITION	WEIGHT	I/O TYPE
10	Data Bit - Binary	1	Input
11	Data Bit - Binary	2	Input
12	Data Bit - Binary	4	Input
13	Data Bit - Binary	8	Input
14	Data Bit - Binary	16	Input
15	Data Bit - Binary	32	Input
16	Data Bit - Binary	64	Input
17	Data Bit - Binary	128	Input
110	Channel 1 This bit is used in ladder logic to sense when the data received at the inputs is for this channel.		Input
111	Channel 2 Sense bit		Input
112	Channel 3 Sense bit		Input

Table 6-15. I/O Point Definition - Continued

I/O POINT	DEFINITION	WEIGHT	I/O TYPE
113	Channel 4 Sense bit		Input
114	This output combined with the following output can be set to selectively scan only 1 channel, instead of all 4. These outputs are ignored if the scan selection output is on. The desired channel is selected by setting these two outputs in the ladder logic to the state, as shown below, for that channel.		Output
115			Output
OUTPUT 114	OUTPUT 115		CHANNEL
0	0		1
1	0		2
0	1		3
1	1		4
116	Not used		
117	Scan selection output. This bit must be set for the module to read data input, unless the selected channel scan outputs are used. This output is set in the ladder logic program		Output

Sample Ladder Logic

Sample ladder diagrams are provided below using the same I/O referencing as is used in defining the I/O points in Table 6.15 on the previous page. These are examples of programming the Series One Plus.

Example 1. If all channels are to be scanned, output 117 must be on.

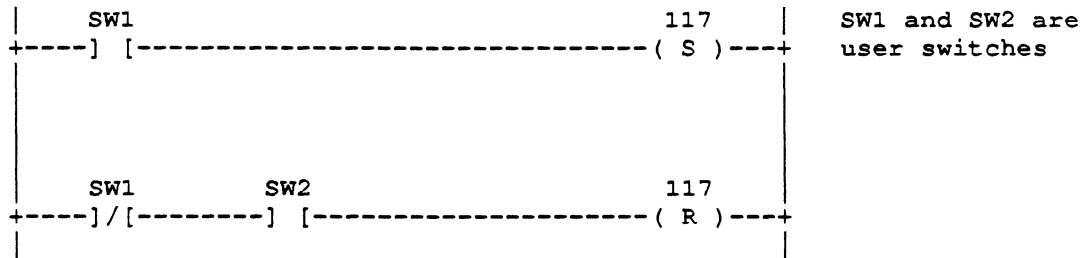

GEK-90842

Example 2. This example of ladder logic allows you to select the channel to be scanned.

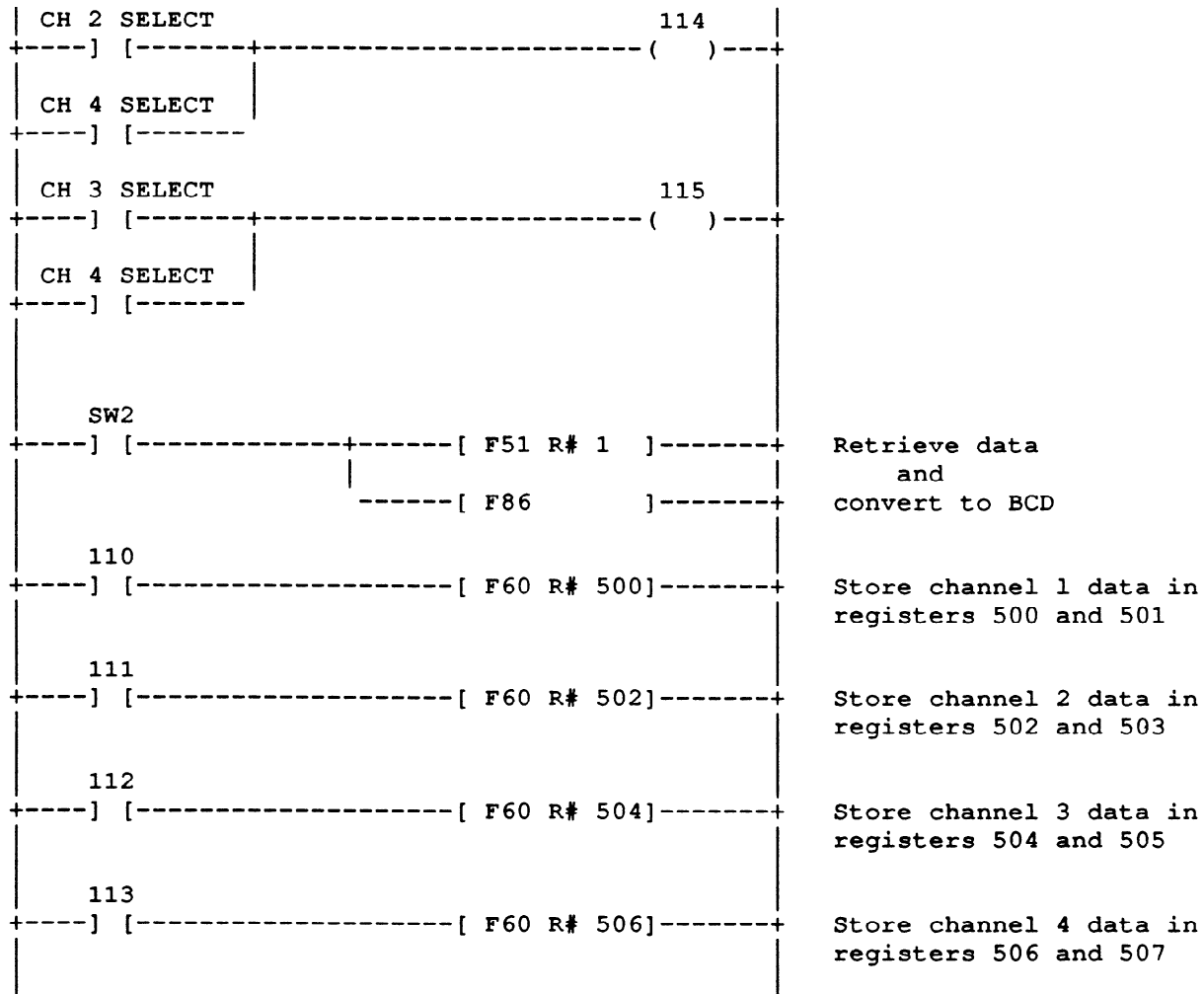

The Function codes used in the above example are as follows:

F51 = D STR1 (Data Store 1), F86 = BIN to BCD, F60 = D OUT (Data Out)

Analog Input Module Features

Figure 6.58 is an illustration of the faceplate for the Analog Input module, showing its features and user wiring connections.

a41896

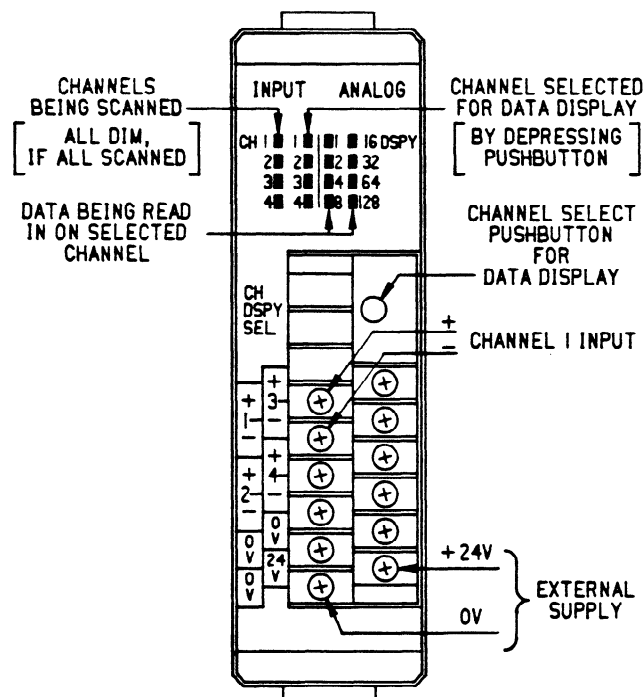

Figure 6-58. Analog Input Module Faceplate

Selection Of Operating Mode

The mode of operation, either 1 to 5 V or 4 to 20 mA is determined by the absence or presence of jumper plugs on pins that are located on the side of the bottom circuit board. There are four sets of pins (2 pins in each set), with one set for each channel. The first set of pins is labeled CH1 and the last set of pins is labeled CH4. The factory default setting is for 1 to 5 V operation, which is no jumper present. To select the 4 to 20 mA mode of operation for any channel, place a jumper on the two pins for the channel or channels and push the jumper firmly onto the pins.

GEK-90842

Analog Output IC610MDL166

Introduction

The Analog Output module provides two independent output channels, each capable of converting 8 bits of binary data to an analog output. This module can be used with any of the Series One family of programmable controllers. The Series One Plus, in addition to the basic functions, provides data operations (including math functions), which allows other types of operations to be performed when using the analog output module. Each Analog Output module requires 16 I/O references for addressing.

Although this module can be used with the Series One and Series One Junior, in addition to the Series One Plus, certain programming techniques will make better use of the capabilities of the Analog Output module with these PCs. An APPLICATION NOTE will be issued explaining those techniques in detail.

Hardware Features

Each channel can provide either a voltage output (0 to +10 V dc) or current output (4 to 20 mA source). Voltage or current selection for each channel is user selected by how the field wiring is connected on the screw terminals on the faceplate. Resolution is 8 bits, which allows a maximum digital value of 255 to be converted. Eight LEDs for each channel on the faceplate provide an 8-bit binary display of the data output for each channel.

User field wiring is made to a removable terminal board on the module's faceplate. A hinged plastic terminal cover on the terminal board protects the terminals. The terminal cover has a removable label that can be used to record circuit information.

The maximum conversion time is 10 microseconds and does not add to the scan time of the CPU. Both channels are converted with each scan.

Power Requirements

This module requires an external 24 V dc power supply. The 24 V dc supply in Series One racks can be used, however the current provided by the rack is 100 mA, which is sufficient current for one Analog Output channel, since the module requires up to 85 mA for operation. The maximum load for both channels is 170 mA.

General and Electrical Specifications

Specifications for this module are provided in the following table.

Table 6-16. Analog Output Module Specifications

Number of Channels	2 (Independent)
Analog Output Ranges	0 to +10 V dc or 4 to 20 mA (selectable for each channel on faceplate terminals)
Resolution	8-bit binary (1 in 256)
Digital Input Data	8 bits, binary from the CPU
I/O Points Required	16 consecutive (per slot assignments for 16 points, 0 to 7 and 100 to 117, etc.)
LED Display (16 LEDs) 8 LEDs for each channel	8-bit binary data display of output data for each channel
Operating Temperature	0 to 60° C (32 to 140° F)
Relative Humidity	5% to 95% (non-condensing)
Output Impedance	< 0.5L (Voltage Output)
Output Current	10 mA, maximum (Voltage Output)
External Resistor	550L, maximum (Current Output)
Conversion Start	At start of CPU's scan
Conversion Time	10 msec, maximum
Accuracy	0.2% at 25°C
Accuracy vs. Temperature	30 ppm (parts per million) per 1°C
External Power Source	+24 V dc, 85 mA (maximum)
9 V dc Power Consumption	55 mA (Supplied by rack power supply)

I/O Reference Definitions

The Analog Output module uses 16 consecutive I/O points, beginning with the first I/O reference assigned to the I/O slot selected for the module. In the table, it is assumed that the Analog Output module is placed in slot 2 of a properly configured 5 or 10-slot CPU rack (references 0 to 10 and 100 to 110). *These references are used for the example only, other valid references for I/O slots that allow 16 references can be used.* The following table defines the use of each of the I/O points.

Table 6-17. I/O Point Definition

I/O POINT	DEFINITION	WEIGHT	I/O TYPE
CHANNEL	DATA	WEIGHT	
0	Channel 1 - Data Bit 1	1	Output
1	Channel 1 - Data Bit 2	2	Output
2	Channel 1 - Data Bit 3	4	Output
3	Channel 1 - Data Bit 4	8	Output
4	Channel 1 - Data Bit 5	16	Output
5	Channel 1 - Data Bit 6	32	Output
6	Channel 1 - Data Bit 7	64	Output
7	Channel 1 - Data Bit 8	128	Output
100	Channel 2 - Data Bit 1	1	Output
101	Channel 2 - Data Bit 2	2	Output
102	Channel 2 - Data Bit 3	4	Output
103	Channel 2 - Data Bit 4	8	Output
104	Channel 2 - Data Bit 5	16	Output
105	Channel 2 - Data Bit 6	32	Output
106	Channel 2 - Data Bit 7	64	Output
107	Channel 2 - Data Bit 8	128	Output

GEK-90842

Sample Ladder Logic

A sample ladder diagram is provided below showing a method of how to move output data to Channels 1 and 2. This is an example of programming the Series One Plus for using the Analog Output module.

Example. Move output data to Channels 1 and 2, using the same I/O references as are used in previous table; i.e., 0 to 7 for Channel 1 and 100 to 107 for Channel 2.

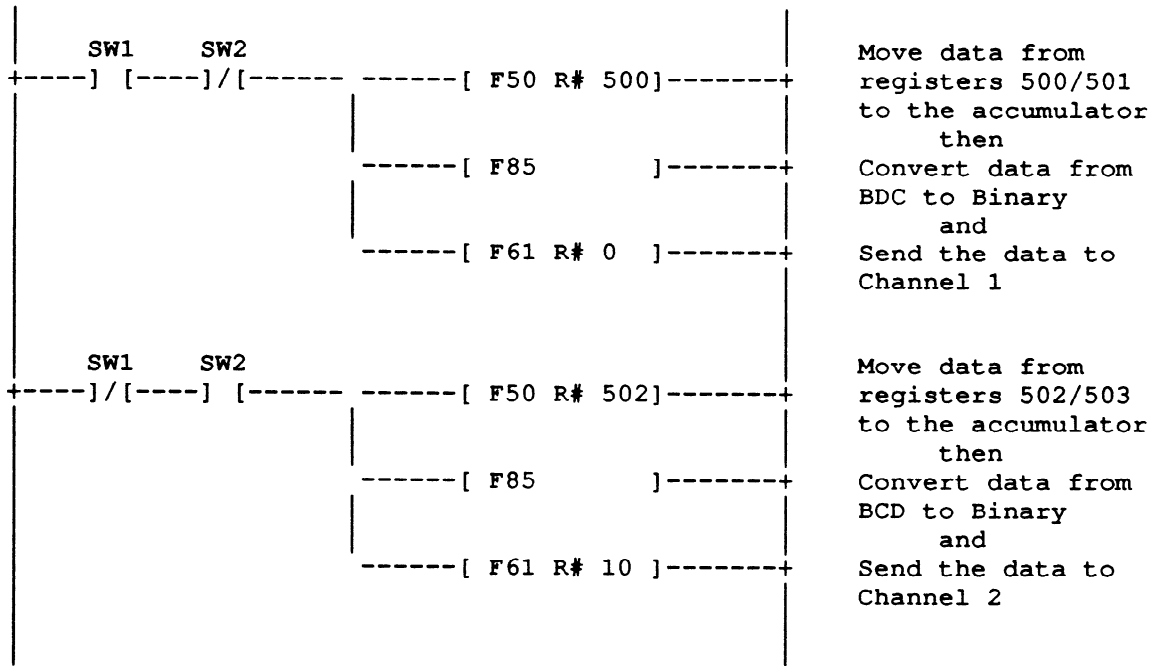

The Function codes used in the above example are as follows:
 F50 = D STR (Data Store)
 F85 = BCD to BIN
 F61 = D OUT1 (Data Out 1)

Analog Output Module Features

Figure 6.59 is an illustration of the faceplate for the Analog Output module, showing its features and user wiring connections.

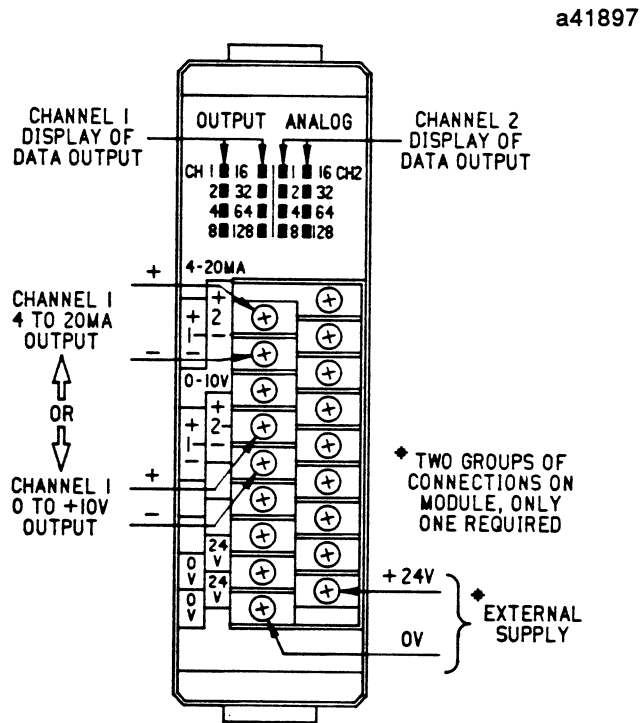

Figure 6-59. Analog Output Module Faceplate

GEK-90842

UL Listed Products

The Series One products that have obtained UL approval or are UL pending are described in the following pages. These products are listed below. As with all products that have obtained UL approval, each listed item has an attached UL label.

- IC610CPU101 Series One CPU. Version C of the CPU is UL Listed. The functionality of the CPU has not changed, all specifications are the same as the previous version.
- IC610CHS111 Series One 5-slot rack. 115 V ac source of input power required.
- IC610MDL135 Series One 115 V ac Input module, 6 circuits.
- IC610MDL181 Series One Relay Output module, 5 circuits.
- IC610MDL185 Series One 115 V ac Output module, 6 circuits.

The following pages contain the technical specifications and wiring information required to implement the Series One UL listed products.

**5-Slot Rack, UL Listed
IC610CHS111**

The 5-slot UL Listed rack is similar to the existing 5-slot rack, IC610CHS110, in that it has a power supply to the right and slots to contain up to 5 modules. *The power supply for this UL rack requires an input power source of 115 V ac.* This rack does not accept 230 V ac input.

As with existing 5-slot rack, a terminal board is provided for field wiring connections, refer to the following figure. The two top terminals are for the 115 V ac HOT (H) and NEUTRAL (N) connections. The next two terminals are for connecting an external device to the RUN relay, the next two contacts (+ and -) provide a 24 V dc output voltage at 100 mA for connection to an external sensor, and the bottom terminal is the common (C) connection to an expansion rack.

When used as the first rack in an installation, it must contain the CPU which is placed in the slot next to the power supply. The rack can also be used as the second or third rack in a system if more I/O is required than can be contained in the first rack. A two-position switch on the inside, left of the rack, must be set determined by location of the rack in the system. For a UL approved installation, do not mix UL approved and non UL racks or modules. Specifications for this rack are as follows:

AC power Required:	115 V ac, 15%
Frequency:	47 to 63 Hz
Maximum Load:	0.8 A, max.
Output Current:	1.4 A, at 5 V dc 0.8 A, at 9 V dc 0.5 A, at 24 V dc

b41930

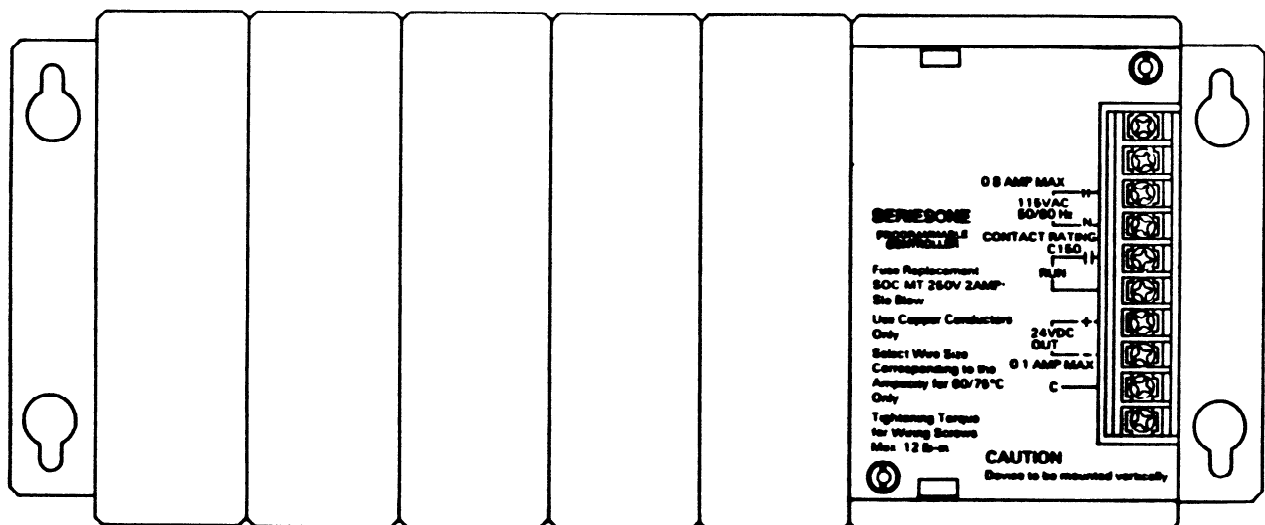

Figure 6-60. UL Listed 5-Slot Rack

GEK-90842

**115 V ac Input Module, UL Listed
IC610MDL135**

This UL listed module provides 6 circuits, each designed to receive a single discrete (ON or OFF) signal from user supplied devices. Examples of these devices include limit switches, pushbuttons, selector switches, and relay contacts. The 6 circuits are grouped together and share a single common terminal. Power to operate the field devices must be supplied by the user. An LED, viewed on the faceplate, provides a visible indication of the ON or OFF state of each circuit. Specifications for each of the 6 circuits are provided below:

Input Points	6
Operating Voltage	97 to 132 V ac
AC Frequency	47 to 63 Hz
Input Current	7 mA per point maximum
Input Impedance	9.5 K ohms
ON Level	> 80 V ac
OFF Level	< 20 V ac
OFF to ON Response	10 to 30 ms
ON to OFF Response	10 to 60 ms
Circuit Indicator	Field Side
Internal Power Consumption	10 mA at 9 V dc
Units of Load	1 unit (9 V dc)

a41924

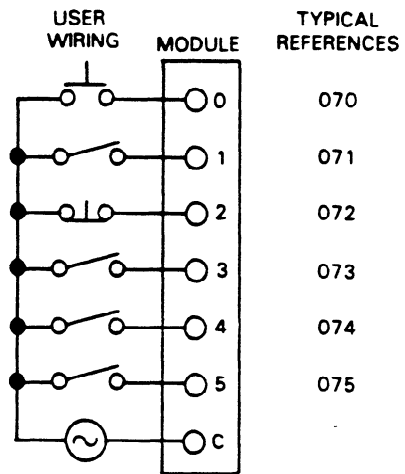

a41687

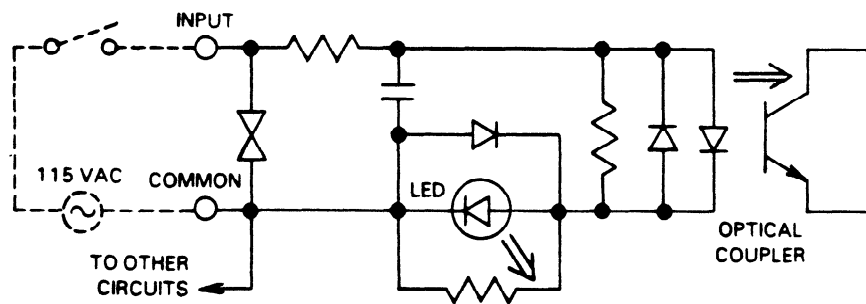

Figure 6-61. Wiring for UL Listed 115 V ac Input Module

**Relay Output Module, UL Listed
IC610MDL181**

This UL listed module provides 5 circuits, each capable of controlling user supplied discrete (ON or OFF) loads. These loads typically include relay coils, motor starters, solenoid valves, annunciation devices and indicator lights. Since this module is not designed to operate with a specific current type such as 115 V ac or 24 V dc. It can be used to control a wide variety of loads and signal types. The relay contact rating for this module is C150.

The 5 circuits are arranged in one group, with 2 common connections, which are tied together internally. Power to operate the field devices must be supplied by the user. An LED, viewed on the faceplate, provides a visible indication of the ON or OFF state of each circuit.

Outputs	5
Operating Voltage	5 to 132 V ac/dc
AC Frequency	47 to 63 Hz
Contact Rating	C150
Current, Continuous	2.5 Amps
Current, Make, 120 V	15 Amps
Current, Break, 120 V	1.5 Amps
Maximum Leakage Current (across contacts)	1 mA
Smallest Recommended Load	5 mA
Maximum Inrush	5 amps
OFF to ON Response	5 ms
ON to OFF Response	4 ms
Circuit Indicator	Logic Side
Fuses (Internal)	(1) 10 amp, replaceable
Internal Power Consumption	45 mA for each ON circuit at 9 V dc
Units of Load	23 Units at 9 V dc

a41925

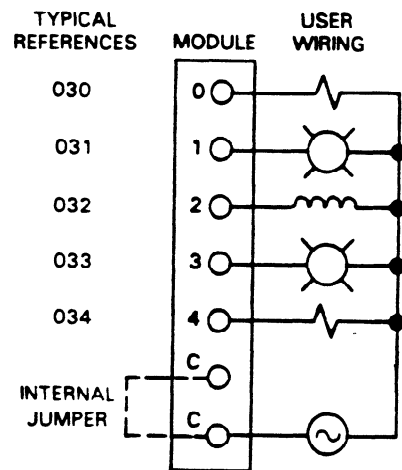

a41689

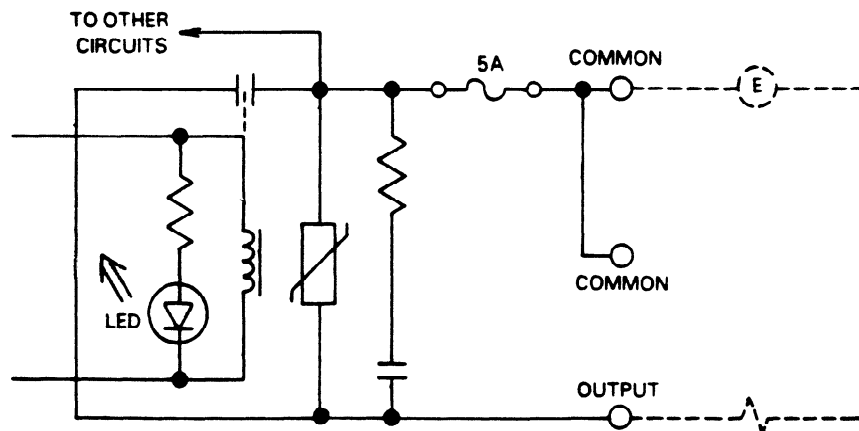

Figure 6-62. Wiring for UL Listed Relay Output Module

GEK-90842

**115 V ac Output Module, UL Listed
IC610MDL185**

This UL listed module provides 6 circuits, each capable of controlling user supplied discrete (ON or OFF) loads. These loads typically include relay coils, motor starters, solenoid valves, annunciation devices and indicator lights. The 6 circuits are arranged in two groups, with a single common connection for all circuits. Power to operate the field devices must be supplied by the user. An LED, viewed on the faceplate, provides a visible indication of the ON or OFF state of each circuit.

CAUTION

If this module is wired incorrectly or the listed specifications are exceeded, any damage incurred by the module may not be covered by warranty.

Outputs	6
Operating Voltage	97 to 132 V ac
AC Frequency	47 to 63 Hz
Maximum Current	0.5 amp (per point)
Maximum Leakage Current	0.5 mA at 110 V ac, 60 Hz
ON Voltage Drop	0.8 V dc at 0.5 amp
Smallest Recommended Load	25 mA
Maximum Inrush	10 amps for 16 ms 5 amps for 100 ms
OFF to ON Response	1 ms
ON to OFF Response	8 to 10 ms (1/2 cycle)
Circuit Indicator	Logic Side
Fuses (Internal, soldered)	(2) 5 amp (one for each group of three circuits)
Internal Power Consumption	20 mA for each ON circuit at 9 V dc
Units of Load	12 Units at 9 V dc

a41926

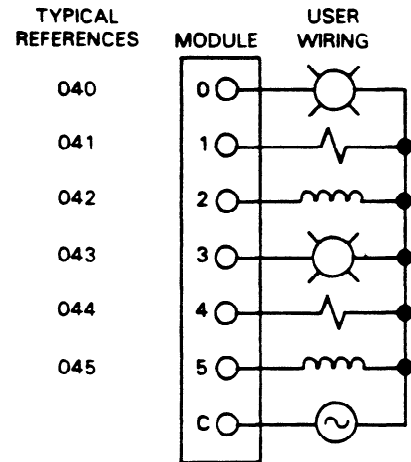

a41688

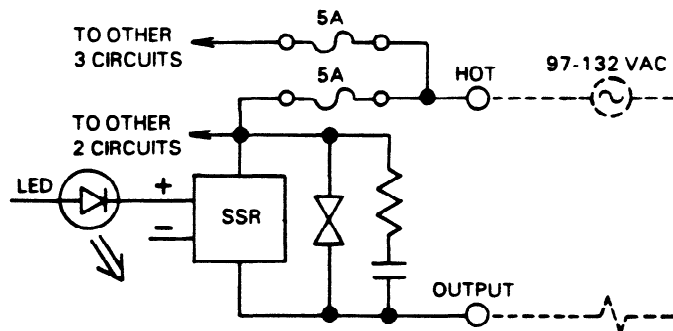

Figure 6-63. Wiring for UL Listed 115V ac Output Module

**115 V ac Input Module (16 Circuits
With Removable Terminal Board
IC610MDL129**

This module provides 16 circuits each designed to receive a single discrete (ON/OFF) signal from user supplied devices. Typical input devices include limit switches, pushbuttons, selector switches, and relay contacts. The 16 circuits are divided into two groups of 8 circuits each. Each group can be supplied from a separate power source. Power to operate the field devices must also be supplied by the user. Figure 6-64 provides wiring information for this module. Following are specifications for each of the 16 circuits.

a42493

Input Points	16
Operating Voltage	80-132 V ac
AC Frequency	47-63 Hz
Input Current	14.5ma @ 60 Hz
Interconnection	2 groups of 8 circuits each
ON Level	Above 80 V
OFF Level	Below 15 V
OFF to ON Response	5-50 ms
ON to OFF Response	5-60 ms
Circuit Indicator	Logic Side
Internal Power Consumption	64 mA @ 9 V dc (Typ)
Units of Load	10 Units @ 9 V dc
Weight	6.4 oz (180 g)

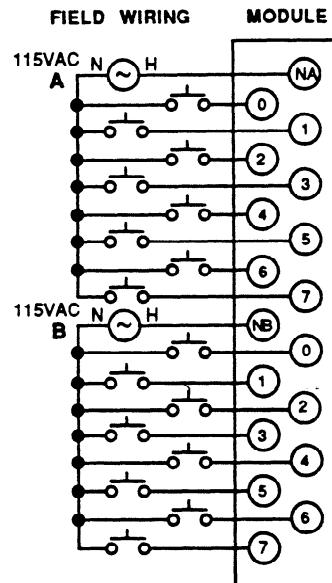

a42308

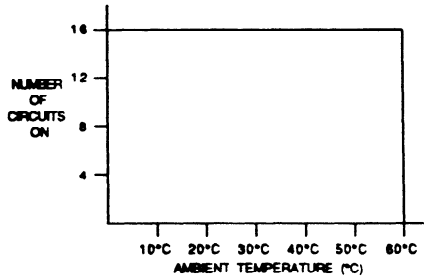

Figure 6-64. I/O Points vs Temperature Chart

a42362

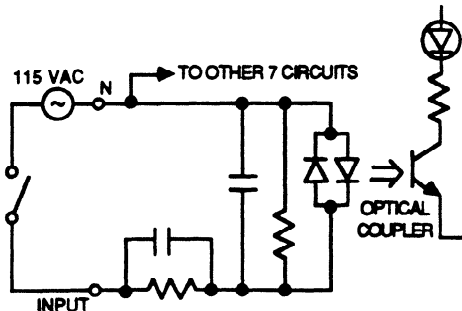

Figure 6-65. Wiring for 115 V ac Inputs with Removable Terminal Board

GEK-90842

**115/230 V ac Output Module (8 Circuits)
with Removable Terminal Board
IC610MDL179**

This module provides 8 circuits each capable of controlling user supplied discrete (ON/OFF) loads. Typical loads include relay coils, motor starters (up to No. 3), solenoid valves and indicator lights. The 8 circuits are divided into 2 groups of 4 circuits each. Each group can be supplied from a separate power source. Power to operate the field devices must also be supplied by the user. Figure 6-65 provides wiring information for this module. Following are specifications for each of the 8 circuits:

Output Points	8
Operating Voltage	80-264 V ac
AC Frequency	47-63 Hz
Maximum Current	1 amp
Maximum Leakage Current	1.2 mA @ 230V, 60 Hz
ON Voltage Drop	1.5V @ 1 amp
Smallest Recommended Load	25 mA
Maximum Inrush	10 amps for 17 ms
OFF to ON Response	1 ms
ON to OFF Response	9 ms
Circuit Indicator	Logic Side
Fuses (Internal, Soldered)	(2) 5 amp (one on each group of 4)
Internal Power Consumption	12 mA for each ON Circuit @ 9 V dc
Units of Load	16 @ 9 V dc
Weight	7.4 oz (210 g)

a42492

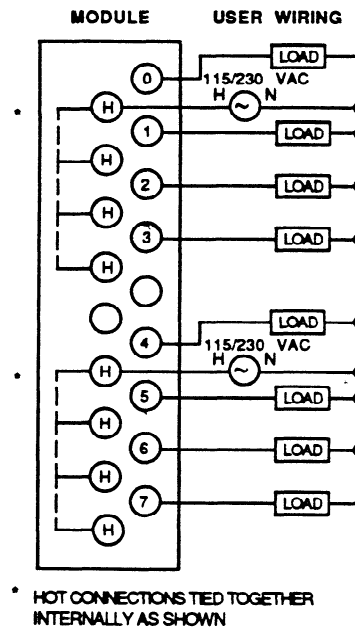

a42367

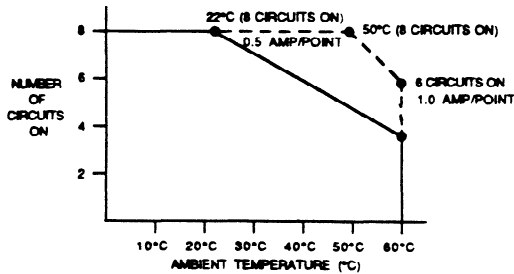

Figure 6-66. I/O Points vs Temperature Chart

a42366

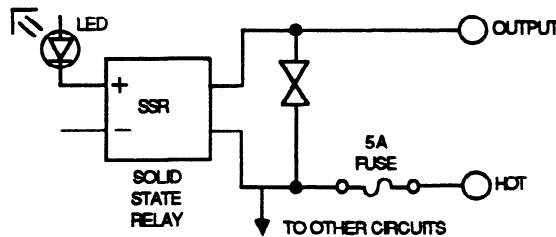

Figure 6-67. Wiring for 115/230 V ac Output with Removable Terminal Board

GEK-90842

Introduction to Maintenance Procedures

The Series One and Series One Plus PCs are designed to provide trouble-free operation. However, occasionally situations requiring corrective action do occur and it is important to be able to quickly identify the source of such situations and correct them. Many times the need for corrective action originates outside of the PC.

Troubleshooting Aids

The advantages provided by the Series One and Series One Plus PC design are indicators and built-in aids to troubleshooting not only the PC, but also the overall control system. The main diagnostic tool is the programmer that can be easily attached to the PC. The programmer provides great insight to the status of the overall control system. When troubleshooting a Series One or Series One Plus PC based control system, make a habit of having a programmer with you.

Basic Troubleshooting Procedure

The following questions should be asked and appropriate action taken to negative answers. At the end of the list of questions are step by step procedures to be followed to replace various modules in a Series One or Series One Plus PC. All major corrective action can be accomplished by replacing modules. No special hand tools are required except for a screw driver and voltmeter. There is no requirement for an oscilloscope, highly accurate voltage measurements (digital voltmeters), or specialized test programs. Refer to figure 7.1 for location of the referenced indicators.

1. Is PWR (Power) light ON? If not, measure power at the input voltage terminals (98-126 V ac or 195-252 V ac as appropriate) on racks using an AC source of power. For racks requiring a DC power source, measure the DC voltage between the +24 and 0 V terminals. If the appropriate AC or DC power is not present, locate the source of the problem external to Series One or Series One Plus PC. If the AC or DC power levels are correct but the PWR light is off, fuses should be checked, then replacement of the CPU rack if necessary.
2. Is CPU light OFF? If ON, check which error code is displayed, refer to table 4.1 for error code definitions and take appropriate action.
3. Is RUN light ON? If not, check for the cause such as the programmer in the PRG or LOAD position or programming errors. If RUN light is OFF and a programmer is not connected, or the programmer in the RUN mode without an error code being displayed, replace the CPU module.
4. Is the BATT light ON? If yes, replace the battery. Since the BATT light is only a warning level, the program may be unaltered even if the battery is low. After replacing the battery, examine the program or test the PC operation. If a fault is located reload the program from tape recorded at the completion of initial system programming.
5. In multiple rack systems if the CPU is operating, the RUN relay can be very useful in verifying operation of the other power supplies. If the RUN relay is not closed (high resistance) check the AC or DC power supply as in step 1 above. Adequate AC or DC power and an open relay requires replacement of the rack.

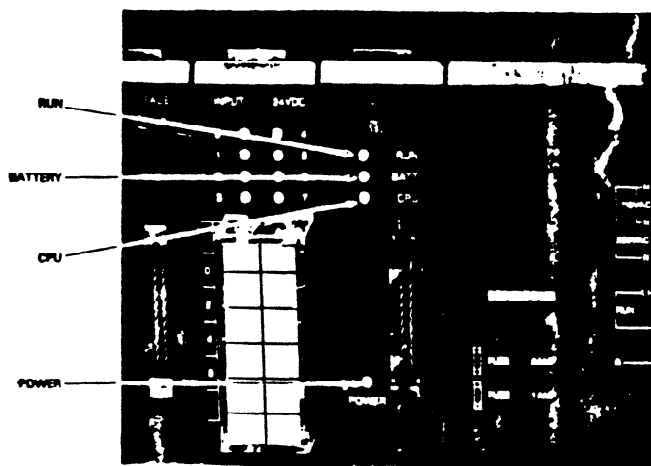

Figure 7-1. Troubleshooting Indicators

General Troubleshooting Procedure

Additional procedures depend upon knowledge of the logic installed by the user. The following steps are more general in nature and should be modified or adjusted as necessary to meet your specific application. There are no better troubleshooting tools than common sense and experience. First plug in the programmer and place it in the RUN mode, then follow these steps:

1. If the Series One or Series One Plus PC has stopped with some outputs energized or basically in mid-stream, locate the signal (input, timer, coil, sequencer, etc.) that should cause the next operation to occur. The programmer will display ON or OFF condition of that signal.
2. If the signal is an input, compare the programmer state with the LED on the input module. If they are different, replace the input module. If multiple modules in an expansion rack appear to require replacement, verify the I/O cable and its connection before replacing any modules.
3. If input state and LED on the input module agree, compare the LED status and the input device (pushbutton, limit switch, etc.). If they are different, measure the voltage at the input module (refer to Chapter 6 for typical I/O wiring). If the voltage indicates a problem, replace the I/O device, field wiring, or power source; otherwise; replace the input module.
4. If the signal is a coil wired to a field device, compare its status to the LED on the output module. If they are different, verify the source of field power to ensure excitation voltage is available. If field power is not present, examine the power source and its wiring. If the proper field power is available, but the status is wrong at the I/O module's output terminal, replace the output module or verify that the rack is providing the proper power to the module.
5. If the signal is a coil and either there is no output module or the output is the same as the coil state, examine the logic driving the output with the programmer and a hard copy of the program. Proceeding from right towards left, locate first contact that is not passing power that is otherwise available to it from immediate left. Troubleshoot that signal per steps 2 and 3 above if it is an input, or 4 and 5 if it is a coil. Ensure that Master Control Relays are not affecting operation of the logic.

GEK-90842

6. If the signal is a timer that has stopped at a value below 9999, other than 0000, replace the CPU module.
7. If the signal is the control over a counter, examine the logic controlling the reset first and then the count signal. Follow steps 2 through 5 above.

Replacement of Components

The following procedures provide details on procedures to be followed when replacing components of a Series One or Series One Plus PC system.

Replacing a Rack

1. Turn OFF power and remove the programmer (if installed).
2. Remove the plastic cover and disconnect power wiring from the terminal board on the lower right side of the rack.
3. Remove all I/O modules. I/O wiring does not have to be disturbed if service loop was provided during the original installation. Note the position of each module in the rack for proper reinstallation.
4. Remove CPU module (if installed) and any filler modules. Place them aside in a safe location for later reinstallation.
5. Remove bottom two bolts holding the rack in place. Loosen but do not remove the top bolts.
6. Slide base unit up and then pull forward to clear the top mounting bolts. Set the rack aside.
7. Reinstall the new rack onto the top mounting bolts.
8. Insert bottom bolts and tighten all four mounting bolts.
9. Install the I/O modules in the same slots from which they were removed.

WARNING

Placing a module in the wrong slot can cause incorrect and dangerous operation of the control system.

10. Install the CPU and any filler modules that were removed.
11. Reconnect power wiring to the terminals on the right side of the rack. Reinstall the plastic cover over the power terminals.
12. Verify proper power wiring and then turn power ON. Carefully check operation of the entire system to ensure that all I/O modules are in their proper locations and the program is not altered.

Replacing a CPU Module

1. Turn OFF power and remove the programmer (if installed).
2. Squeeze the CPU module at the front, top and bottom to release securing tabs.
3. Pull the module straight out from its slot.
4. If PROM memory had been installed in the CPU, remove the PROM and install it in the new CPU.

5. Insert the new CPU module by first aligning the printed circuit boards into the bottom board guide.
6. Rotate the module upwards slightly to engage the top board guide.
7. Push the CPU module into the rack until both tabs snap into place.
8. Reinstall the programmer and reapply power.
9. Reload the program from tape recorded after initial system programming. Check operation of entire system.

Replacing I/O Modules

1. Turn OFF power from both the rack and the I/O system.
2. Remove the plastic cover from over the terminals on the I/O module to be replaced. Only field wiring on the defective module needs to be removed.
3. Disconnect field wiring from I/O terminals, detach the removable connector, or remove the connector to the I/O Interface cable, as applicable according to the type of module. Label each wire or note installed wire marking for future reconnection.
4. Squeeze the I/O module at the front, top and bottom to release securing tabs.
5. Pull the I/O module straight out.
6. Insert the new I/O module, aligning printed circuit boards first into the bottom board guide.
7. Rotate the module slightly upwards to engage the top board guide.
8. Push the module into the rack until both tabs snap into place.
9. Reconnect all field wiring, replace the removable connector board or replace the connector, then replace the plastic cover.
10. Reapply power to the CPU, then to the I/O system. Check operation of the system, especially the I/O module that was replaced.

Replacing the Battery

If the CMOS memory back-up battery requires replacement, refer to the following procedures. Figure 7.2 shows the battery location on the CPU, location of the battery connector and the battery tie-down straps.

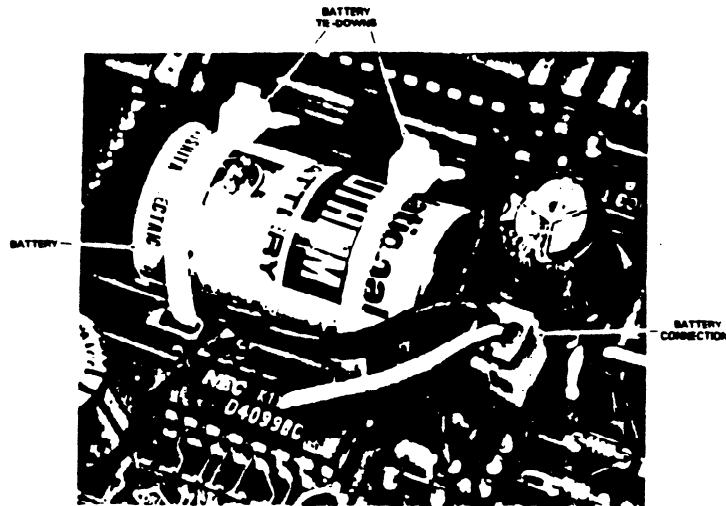

Figure 7-2. Battery Location and Connection

1. Remove the CPU following the previous instructions.
2. Cut the plastic tie down straps that secure the battery to the board.
3. Disconnect the battery. There is sufficient capacitance in the system to retain the CMOS memory contents even without the battery for about 20 minutes.

WARNING

The lithium battery should be handled with care. **DO NOT** discard the battery in fire. **DO NOT** attempt to recharge the battery. **DO NOT** short the battery. If these precautions are not followed, the battery may burst, burn or release hazardous materials.

4. Connect the new battery (catalog no. IC610ACC150) and place it in its proper position on the printed circuit board.
5. Secure with new tie downs or insulated wire.
6. Reinstall the CPU module.
7. Verify that the BATT light is OFF. If necessary, reload the CPU from a tape made after initial system programming. Then, check operation of the entire system.
8. If the two printed circuit boards that make up the CPU are separated, ensure that they are reconnected, installed in a rack, and powered up. Otherwise, logic may lock into a high current drain mode and prematurely drain the battery.

Adding Memory

The following procedure should be followed when adding memory to a Series One or Series One Plus PC. Either CMOS RAM memory can be added to increase memory capacity from 700 words to 1724 words or non-volatile PROM memory can be installed that contains a program previously entered into the PROM.

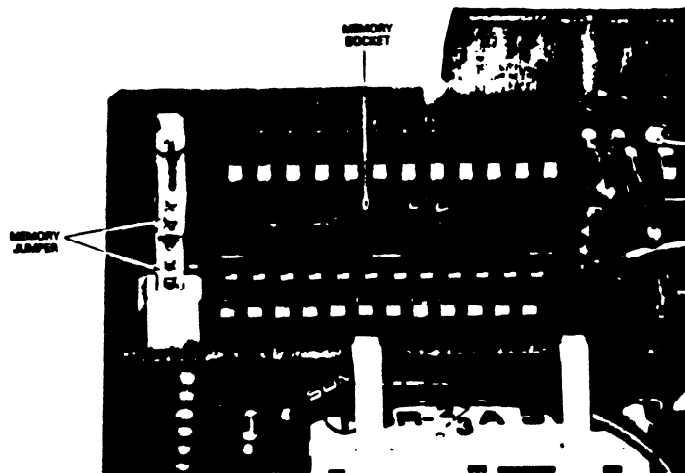

Figure 7-3. Location of Extra Memory Socket

1. Before installing additional memory, it is recommended that any program currently in memory be recorded on tape. If this is not done, the program will be lost after memory is added and a Clear All Memory operation is performed.
2. Remove the CPU following previous instructions.
3. Locate spare memory socket at the rear of the larger printed circuit board in the CPU.
4. Obtain the required memory IC either type 6116LP for Series One or 6264LP-15 for a Series One Plus, 2K x 8 bit CMOS RAM (or equivalent). If adding PROM memory, obtain an Intel type 2732A-2 for Series One or a 27256-25 for a Series One Plus (or equivalent PROMs). Ensure that the CMOS RAM or PROM is correct for your PC.

CAUTION

When handling CMOS memory ICs, always handle by the case and not leads. Static electricity on leads can damage internal circuits. This damage may not be apparent for several days or weeks of operation.

5. Orient the IC so that the notch at one end matches the notch in the memory socket.
6. For clearance when installing memory ICs, it may be necessary to lift the smaller printed circuit board 1/8" (3mm). Do not separate the boards. After the memory IC is installed, reseal the smaller board.
7. Insert the IC into the socket carefully and evenly so as not to bend any leads. Visually inspect to ensure that all leads are in place and then push down to firmly seat the IC. If necessary, readjust the jumpers and/or switch 2 as shown in table 3.2.
8. If the two printed circuit boards that make up the CPU are separated ensure that they are reconnected, installed in a base unit, and powered up. Otherwise, logic may lock into a high current drain mode and prematurely drain the battery.
9. Reinstall the CPU module following previous instructions.

GEK-90842

10. Power-up the CPU, place the mode switch in the PRG position and perform a Clear All Memory operation (CLRSHF348DELNXT). The entire memory will now be entirely clear of data. Any program previously recorded on tape can now be loaded into the CPU from tape or a new program can be entered.

Spare Parts and Components

To support the Series One or Series One Plus PC, an Accessory Kit is available (IC610ACC120). This kit includes commonly needed components that may get damaged or lost in the normal course of operation. For a complete list of accessories for the Series One Family of programmable controllers, refer to GEP-762. Rather than attempting to place orders for plastic covers, fuses, audio cables, screws, etc., this kit can be ordered and provides sufficient material to support 3-5 CPUs depending upon their I/O count. Included in the kit are the following items:

ITEM	QTY.	ITEM	QTY.
Cable, Programmer to Tape Recorder	1	Fuses, 2A SB (Spiral Element)	3
Cable, Programmer to Peripheral	1	Fuses, 3A FB	5
Cover, CPU Connector	1	Fuses, 3A SB	5
Cover (large), DCU, PROM Writer, Printer Interface	2	Fuses, 4A SB	3
Cover (small), DCU, PROM Writer, Printer Interface	1	Fuses, 5A FB	3
Cover, I/O Terminal	4	Fuses, 10A SB	5
Cover, Power Supply Terminal	2	Key, Hand-Held Programmer	1
Cover, Rack Dust	1	Screws, PH (M3x5)	10
Fuses, 1A SB	5	Screws, PH (M3x7)	10
Fuses, 2A SB	3	Screws, PH (M3x16)	10
		Spacer	3

When supporting a Series One or Series One Plus installation, it is recommended that spare modules be available on site. These are in addition to the Accessory Kit previously discussed. As a guide to your requirements, the following percentages are presented. As a minimum, one each of all modules is recommended. Depending upon a number of application related conditions (location, average weekly hours of operation, cost of downtime, etc.) more units may be justified.

UNIT	% SPARES
Base with Power Supply	15
CPUs	15
Input Modules (each type)	10
Output Modules (each type)	15
Programmeters	10
Cables	10
Peripheral Devices	10



Figure 7-4. Accessory Kit for Series One/One Plus

Fuse List

Table 7.1 is a list of fuses used in Series One I/O modules.

Table 7-1. I/O Module Fuse List

I/O MODULE CATALOG NUMBER	CURRENT RATING (AMPS)	QUANTITY	CIRCUIT CONNECTION	TYPE OF FUSE
IC610MDL103	3 Amps	1	soldered	pico fb
IC610MDL104	10 Amps	1	fuse clip	miniature sb
IC610MDL115	3 Amps	2	fuse clips	miniature sb
IC610MDL151	3 Amps	2	soldered	pico
IC610MDL153	5 Amps	4	fuse clips	miniature fb
IC610MDL154	5 Amps	4	fuse clips	miniature fb
IC610MDL155	3 Amps	2	soldered	pico
IC610MDL156	3 Amps	4	soldered	pico
IC610MDL157	3 Amps	2	soldered	pico
IC610MDL158	5 Amps	2	soldered	pico
IC610MDL175	5 Amps	2	soldered	pico fb
IC610MDL176	3 Amps	4	fuse clips	miniature fb
IC610MDL180	10 Amps	2	fuse clips	miniature sb
IC610MDL181	5 Amps	1	fuse clip	miniature
IC610MDL182	2 Amps	2	fuse clip	miniature sb
IC610MDL185	5 Amps	2	soldered	pico

GEK-90842

Application 1 - One-Shots

This application is particularly useful when applied with a Series One PC, since with a Series One Plus PC, a one-shot can be programmed simply by entering the key sequence SET OUT RESET. In many applications, a signal is required that is valid for a very short time period. These signals are called one-shots and are generated by transitions (OFF to ON, or ON to OFF) of a control signal. They are valid for exactly one scan, which is the shortest signal available within the Series One and Series One Plus PCs. Timing for typical One-Shots is as follows:

pc-s1-83-0040

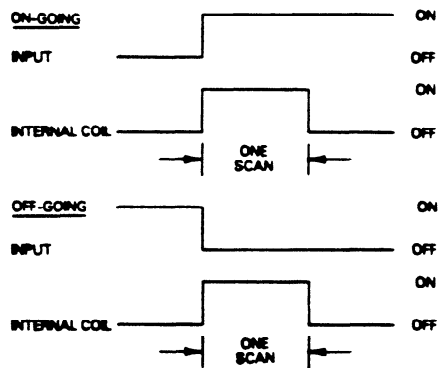

Figure 8-1. Typical One-Shot Timing

In this example, input 01 is the control signal and coil 160 the resulting one shot. Logic for these one-shots is shown below.

pc-s1-83-0041

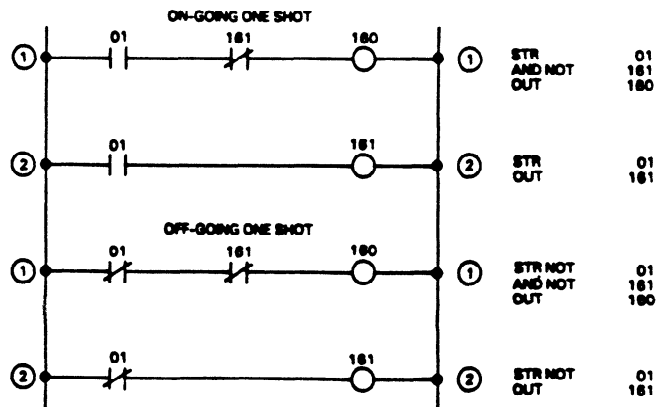

Figure 8-2. Typical One-Shot Logic

Application 2 - Flip Flop

This logic reverses states (ON/OFF/ON/OFF, etc.) each time a control signal is energized. In this example, the Flip/Flop changes state on the OFF to ON transition of the control signal. A typical timing diagram is as follows:

pc-s1-83-0042

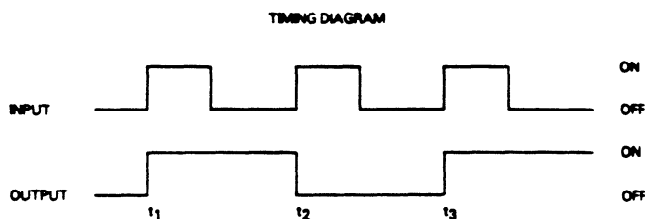

Figure 8-3. Typical Flip-Flop Timing Diagram

In the following typical logic, input 01 is the control signal and output 20 is the flip/flop.

pc-s1-83-0043

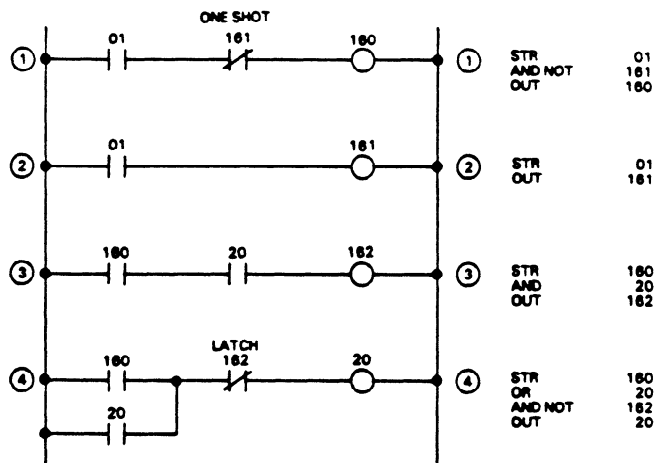

Figure 8-4. Typical Flip-Flop Logic

GEK-90842

Application 3 - Event/Time Drum

Many control requirements can be defined as a sequence of established states for each output. The decision to shift from one step to another can be based upon time or specific input states. To illustrate this concept, the following 6 step example is provided. The control on incrementing the step is a confirmation of both events (for example, input 11) and a time value (for example, timer 601).

Step Number	Input	Time	20	21	22	23	24	25	26	27
1	10	T600	0	1	1	0	1	1	1	0
2	11	T601	0	0	0	0	1	0	0	1
3	12	T602	0	1	1	1	0	1	1	0
4	13	T603	1	1	1	0	0	0	1	0
5	14	T604	1	0	1	1	1	1	1	1

Each step can have different output states and more or less control can be implemented as the application requires. The ladder diagram required to implement this function is as follows:

pc-s1-83-0046

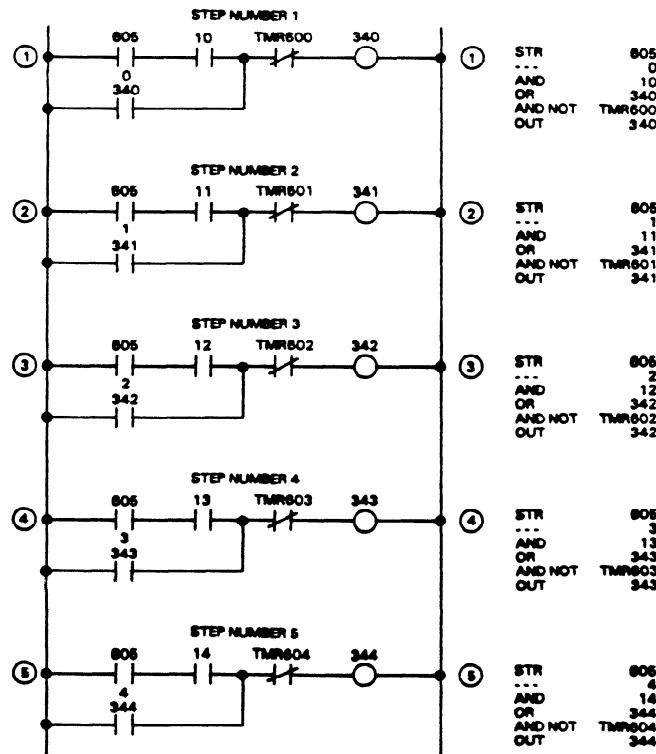

Figure 8-5. Event/Time Drum Logic

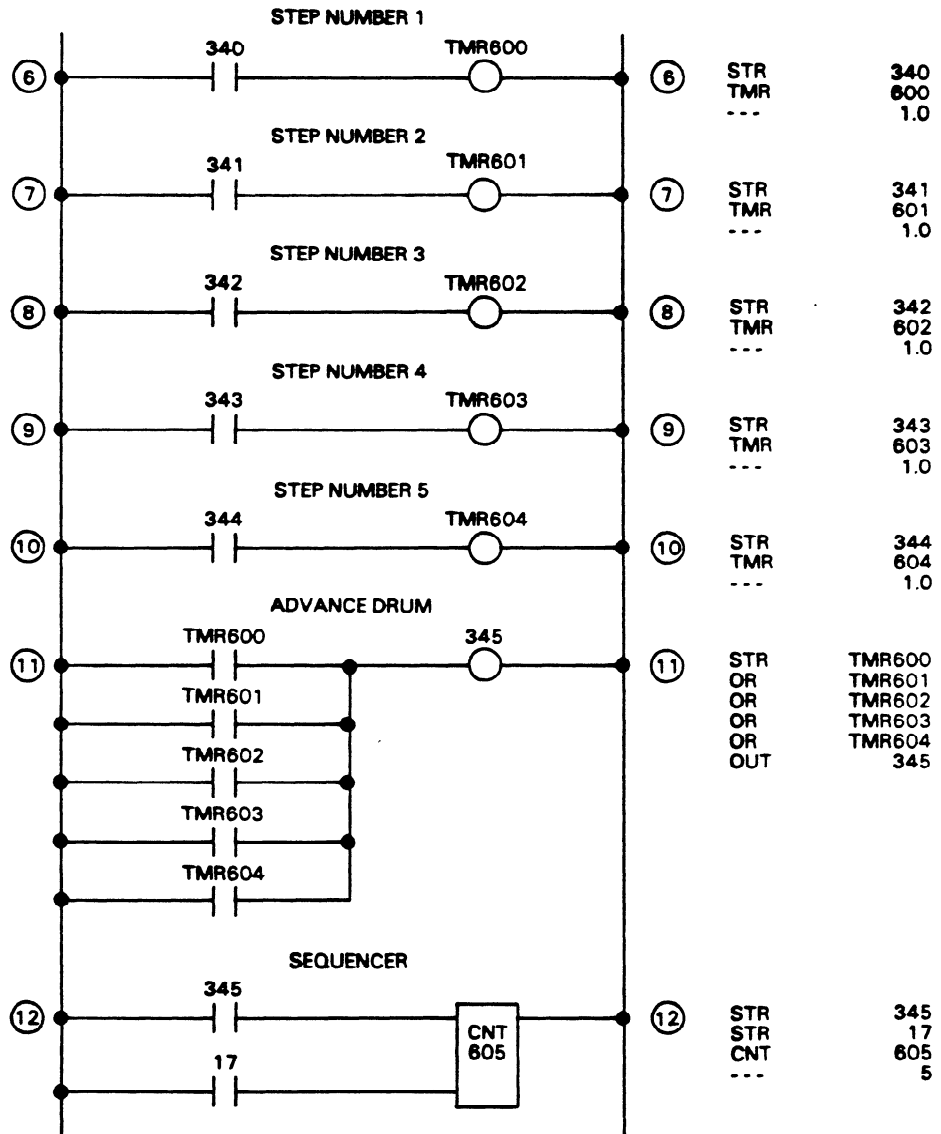

Figure 8-5. Event/Time Drum Logic (Continued)

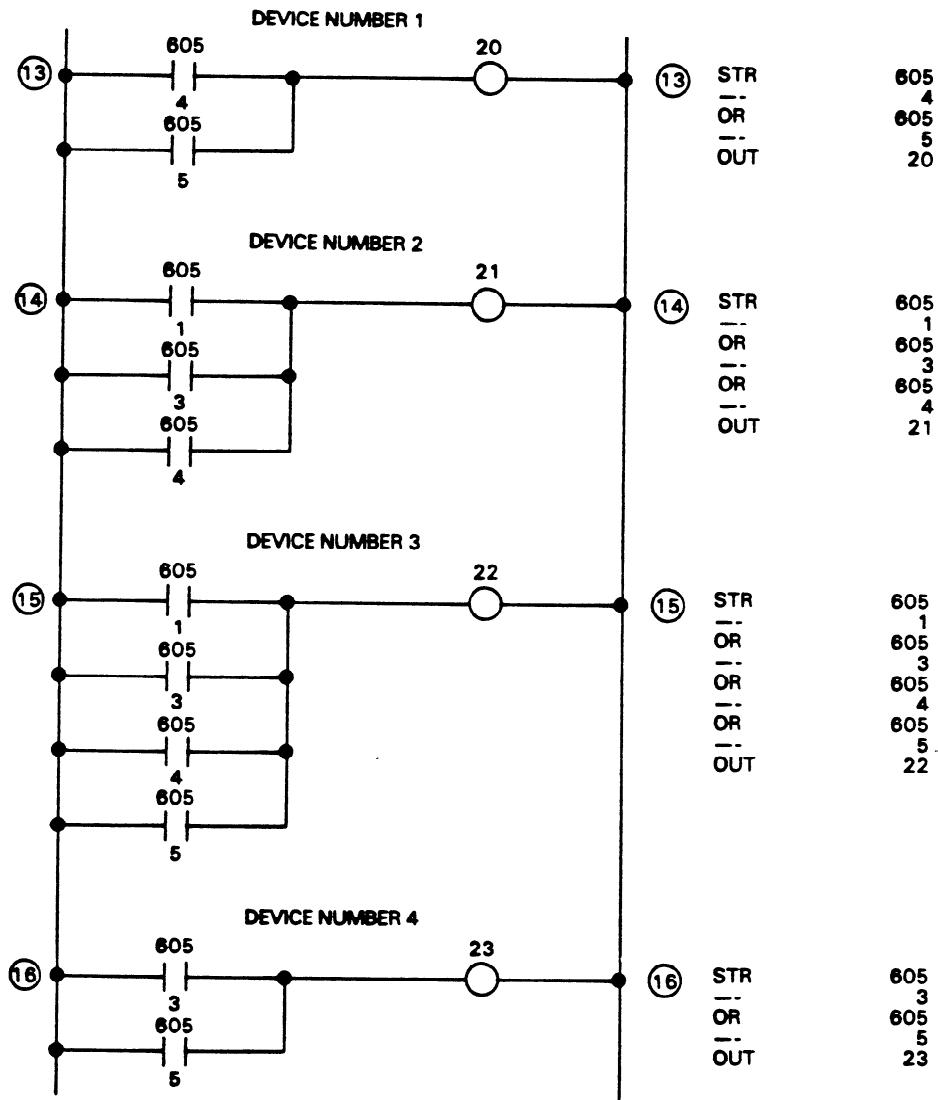

Figure 8-5. Event/Time Drum Logic (Continued)

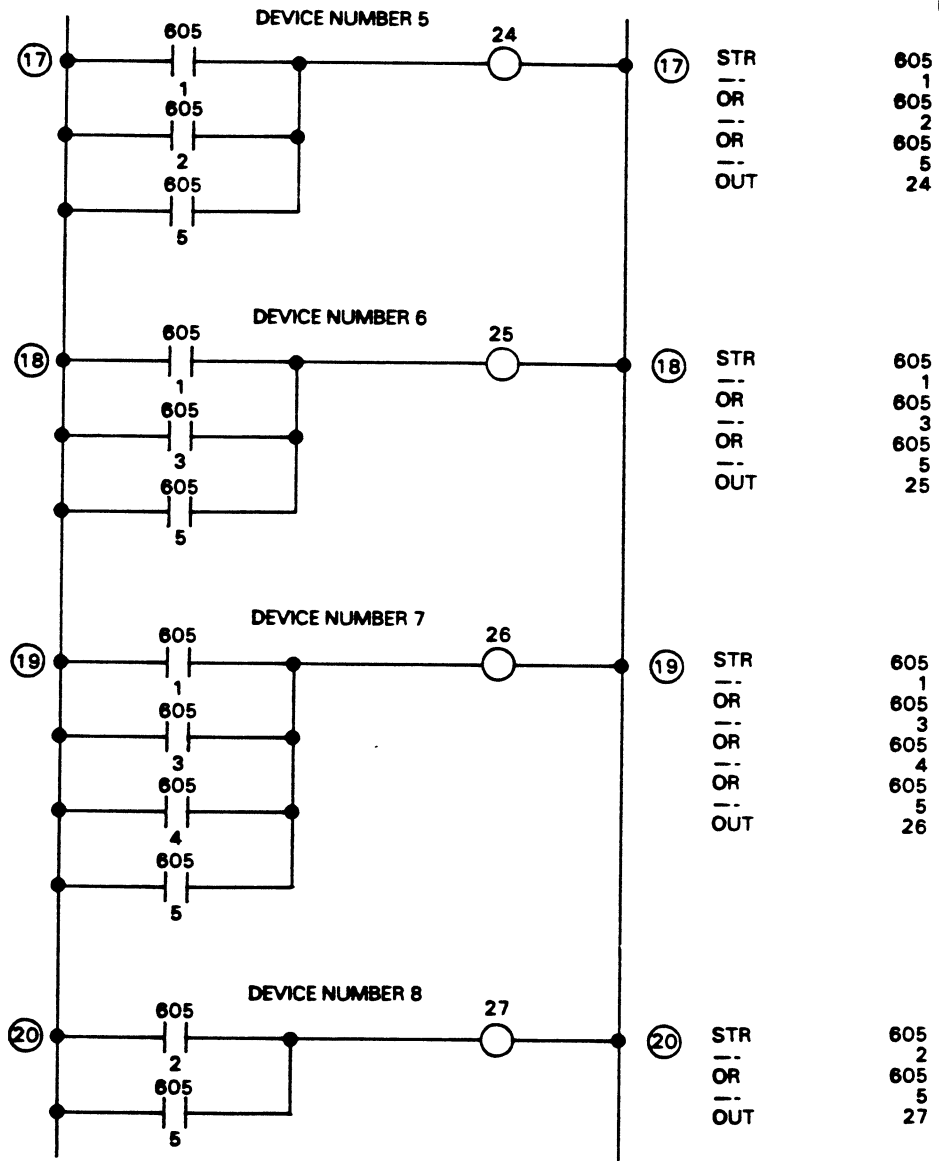

Figure 8-5. Event/Time Drum Logic (Continued)

GEK-90842

Application 4 - Cascaded Counters

If an application requires a counter with presets greater than 9999, multiple counters can be assigned to that function. Two counters can record values up to 99,999,999 and three up to 999,999,999,999 etc. Additional logic is incorporated to generate a reset signal at 10,000 counts instead of the normal 9999.

The following logic uses two counters to record up to 99,999,999 events. Counter 601 records the low order values (thousands, hundreds, tens, and units) and counter 602 the high order values (tens of millions, millions, hundreds of thousands, tens of thousands).

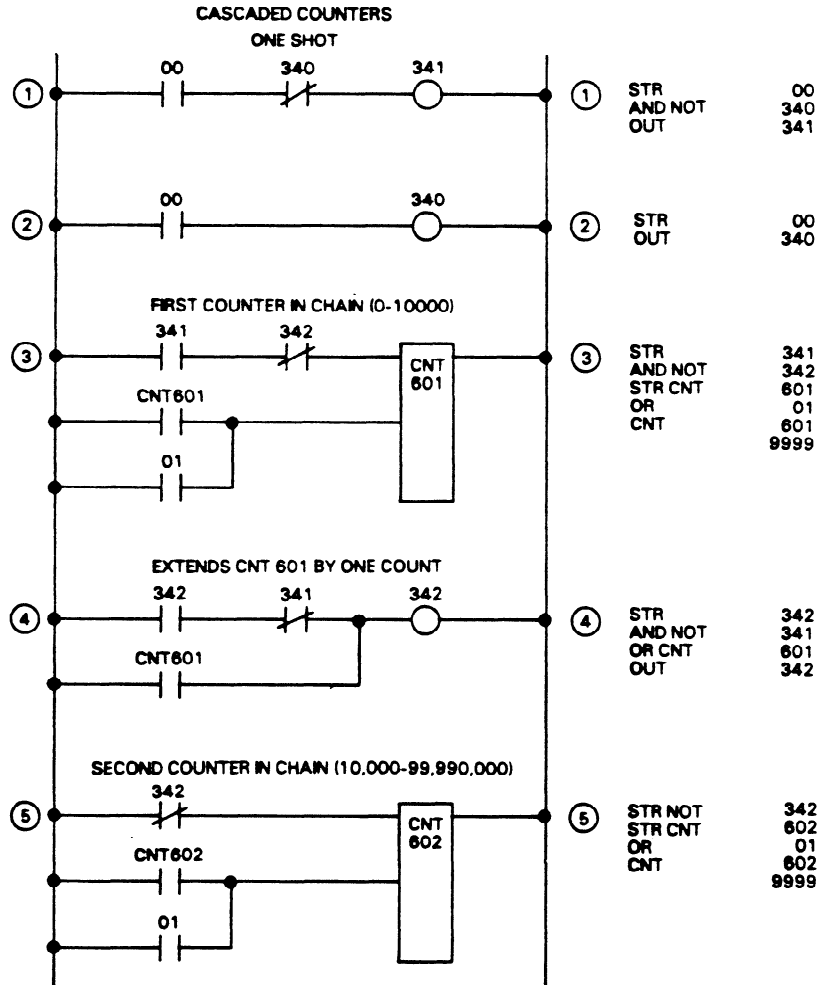

Figure 8-6. Sample Cascaded Counter Logic

Application 5 - Coil 374, Power-Up One-Shot

In industry, power loss to machines and process equipment is a frequent event. When such an event occurs it creates havoc with automatically controlled equipment and processes. The moment power returns it may be desirable to place the machine or process in a "hold" state until verification or critical limits, position of moving parts, and support equipment interfaces are confirmed to be correct by authorized personnel.

Description of Operation

The Series One and Series One Plus PCs have a special function reference (internal coil 374) that provides a pulse during the first scan only after powering up the CPU (or going from program to run mode). Using this pulse in the ladder logic, as shown below, will place the machine or process in the desired hold state.

The instant power returns to an automatic machine or process, certain phases (for instance, activating a cylinder, starting a motor etc.) of the automatic cycle need to be inhibited until a correct state is determined allowing the continuation of the cycle. The following program scheme will inhibit those critical outputs from activating field devices until a reset pushbutton is depressed, thereby, releasing all inhibited outputs and allowing the cycle to continue.

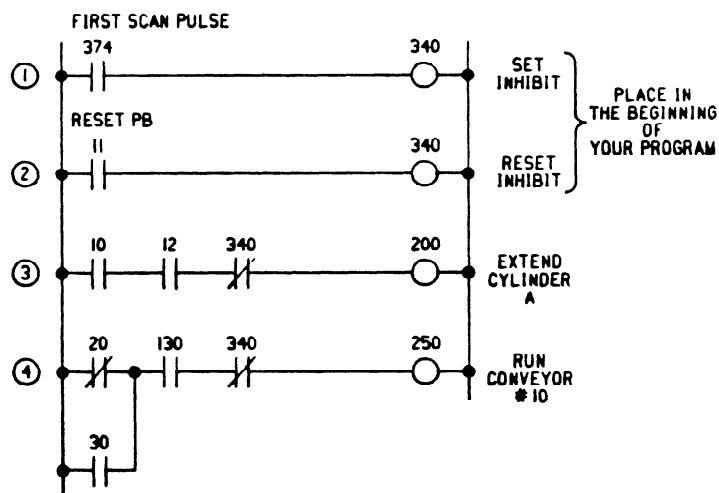

Figure 8-7. Typical Machine or Process Power-Up Inhibit Logic

The program logic in the above figure is an example you can use to inhibit certain phases of a cycle. In this example, when power returns to the process, 374 will be on during the first scan of the CPU, latching coil 340 on. The referenced NC contact of coil 340 is placed in series with the logic that actuates output coils 200 and 250. Even if the program logic is calling for coils 200 and 250 to turn on, they will not until 340 is unlatched. The only way to unlatch 340 is to depress the reset pushbutton (I100), allowing outputs 200 and 250 to be turned on.

GEK-90842

Application 6 - Coil 375, 10Hz Clock

The Series One and Series One Plus PCs have a special function reference that continuously provides a pulse every tenth of a second. The following two examples use the function of this reference (10 Hz Internal Coil 375) to create a cumulative timer and a time of day clock.

Example 1: - Cumulative Timer

In this example, when reference 01 is on, time (in tenths of a second) would be accumulated by counter 600. If the time to be measured is anticipated to be larger than 999.9 seconds, cascading another counter will increase the range to 9,999,999.9 seconds. This technique allows you to measure the duration of an intermittent event that would otherwise reset the standard timer when changing state.

pc-s1-83-0078

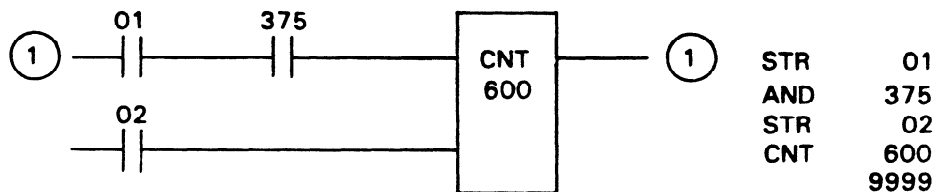

Figure 8-8. Cumulative Timer

Example 2: - Time of Day Clock

In this example, the 10HZ clock (Internal Coil 375) is used to program a time of day clock with reset capabilities. This is a 24-hour time clock, with the time format being XX:YY, where XX = hours (0-23) and YY = minutes (0-59). The 10HZ clock provides the 0.1 second pulse to counter 603 which in turn produces one pulse every second. The remaining three counters, 600, 601 and 602 keep track of seconds, minutes and hours that have elapsed. If power goes off and the clock needs resetting, the combined use of a 3 position switch and a pushbutton, as shown in Figure 8.10, will allow you to set the correct time. The lower portion of Figure 8.10 is the ladder logic which resets the clock. An I/O Simulator module, IC610MDL124, could also be used and programmed to reset the clock).

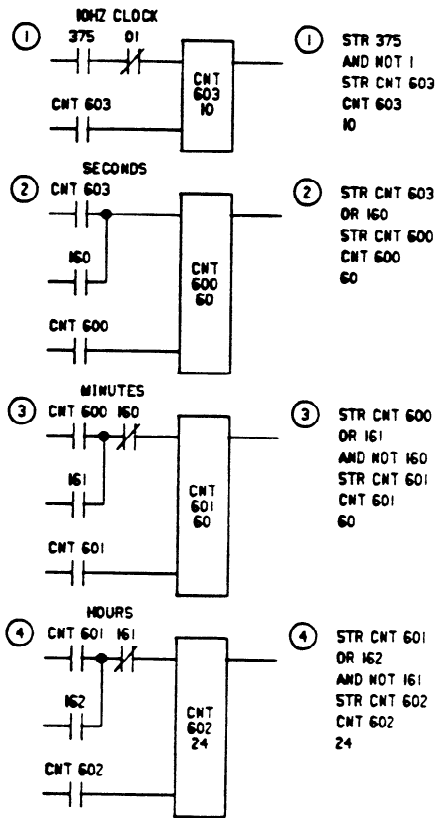

Figure 8-9. Sample 24 Hour Time Clock Logic

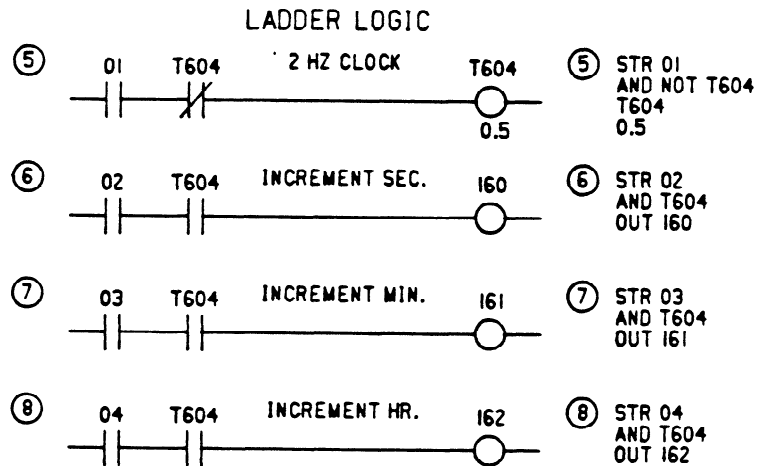
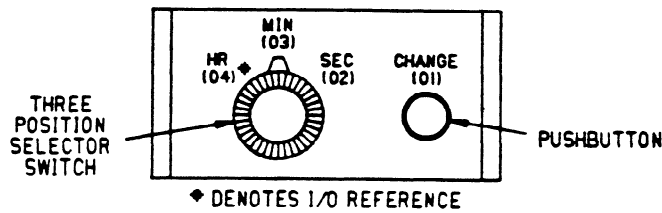

Figure 8-10. Time Clock Resetting

To reset the time, use the following procedure.

1. Select hours, minutes or seconds with the 3 position selector switch.

2. Monitor the appropriate counter.

CNT 600: Seconds

CNT 601: Minutes

CNT 602: Hours

Keystroke sequence is SHF, 6XX, MON

3. Depress the change button until the proper value (time) is displayed on the programmer.

Application 7 - Start/Stop Circuit

A simple but informative application for the Fast Response module is the Start/Stop circuit. In this example, Output 4 is in the Fast Response mode and is controlled by Inputs 0 and No. 1. The timing diagram shows worst case response times.

pc-s1-84-0018

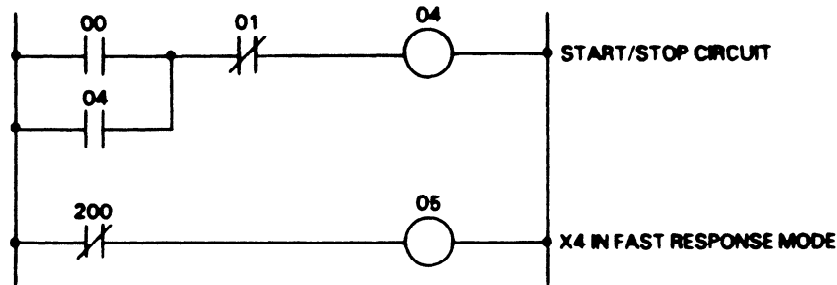

Figure 8-11. Fast Response Start/Stop Logic

I/O REFERENCE	DEFINITION
00	Enable output, X4 in fast response mode
01	Disable output X4 in fast response mode
04	Output X4 tied to field device being controlled
05	Mode select for output X4 DISABLED: manual mode ENABLED: fast response mode
200	Dummy contact to put output X4 in fast response mode

pc-s1-84-0019

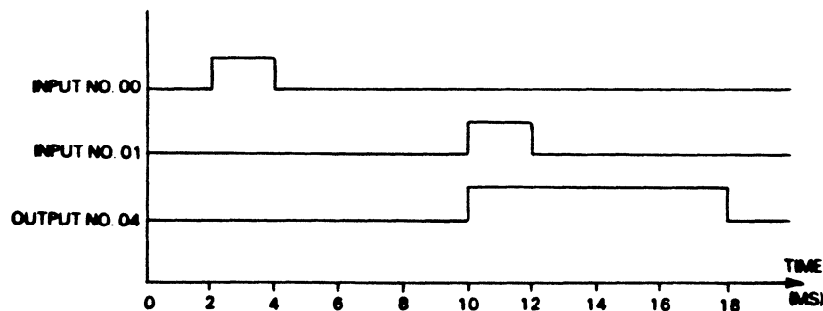

Figure 8-12. Worst Case Timing Diagram

GEK-90842

Application 8 - High Speed Counter Applications

Three general types of application examples will be covered within this application.

1. Programmable CAM Switch
2. Cut to Length
3. Measurement of length

In the development of these applications the following system configuration will be used.

pc-s1-84-0010

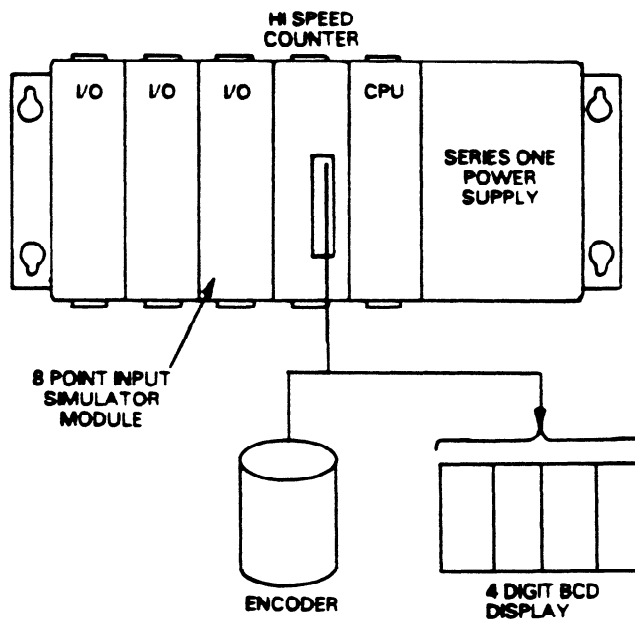

Figure 8-13. Application System

Programmable Cam Switch

The basic concept behind a CAM switch is to enable/disable certain devices at various points in the cycle of a machine. Using one or more high speed counters this type of control can easily be implemented. The following example illustrates this, cycling the high speed counter's two outputs at different preset values. The timing diagram below shows the output logic, with the user program necessary to implement this logic shown on the following pages. This example assumes that the encoder is resetting the counter once per revolution, and that the machine will not travel from one transition point to the next in less than twice the scan time.

a40023

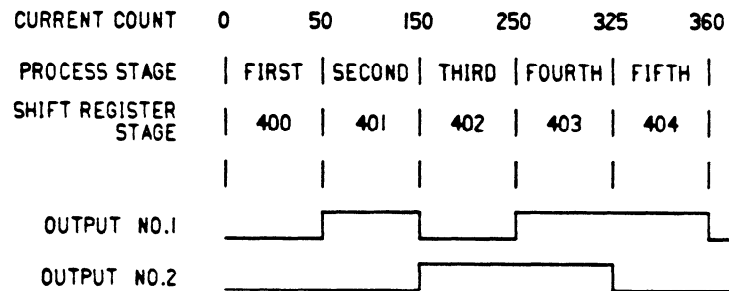

Figure 8-14. Programmable CAM Switch Logic Timing Diagram

a40893

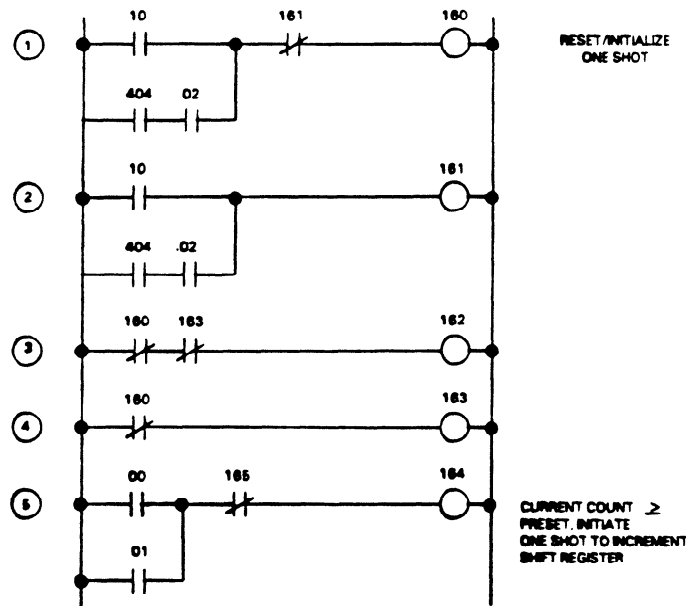

Figure 8-15. Programmable CAM Switch

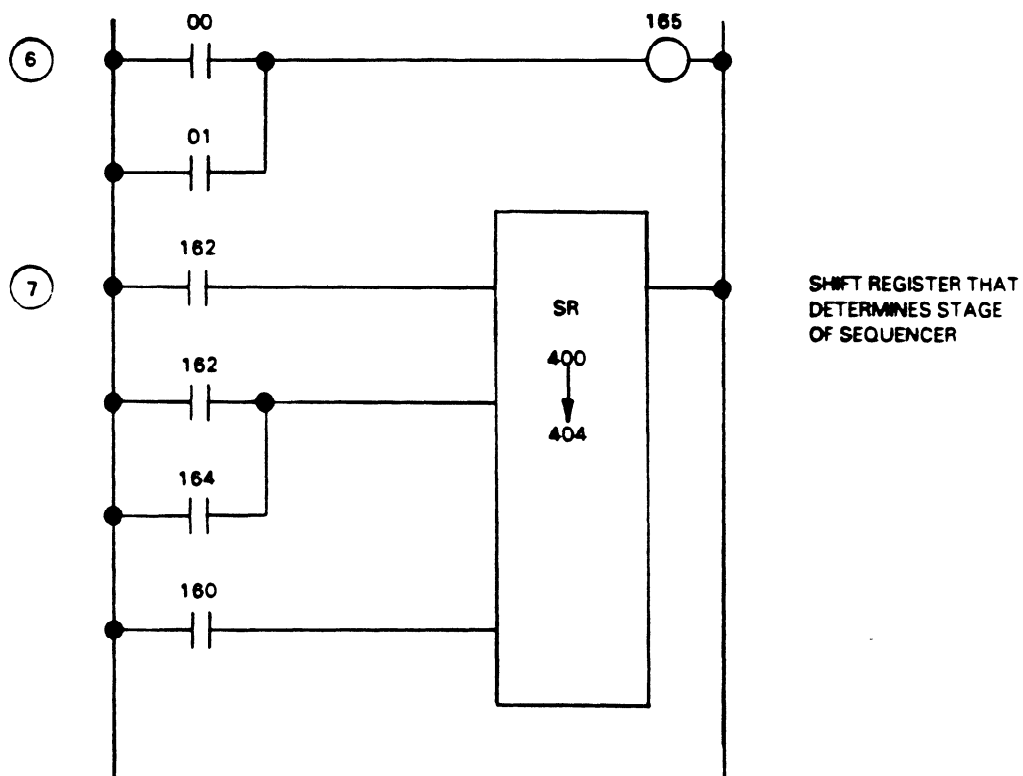

Figure 8-15 Programmable CAM Switch (Continued)

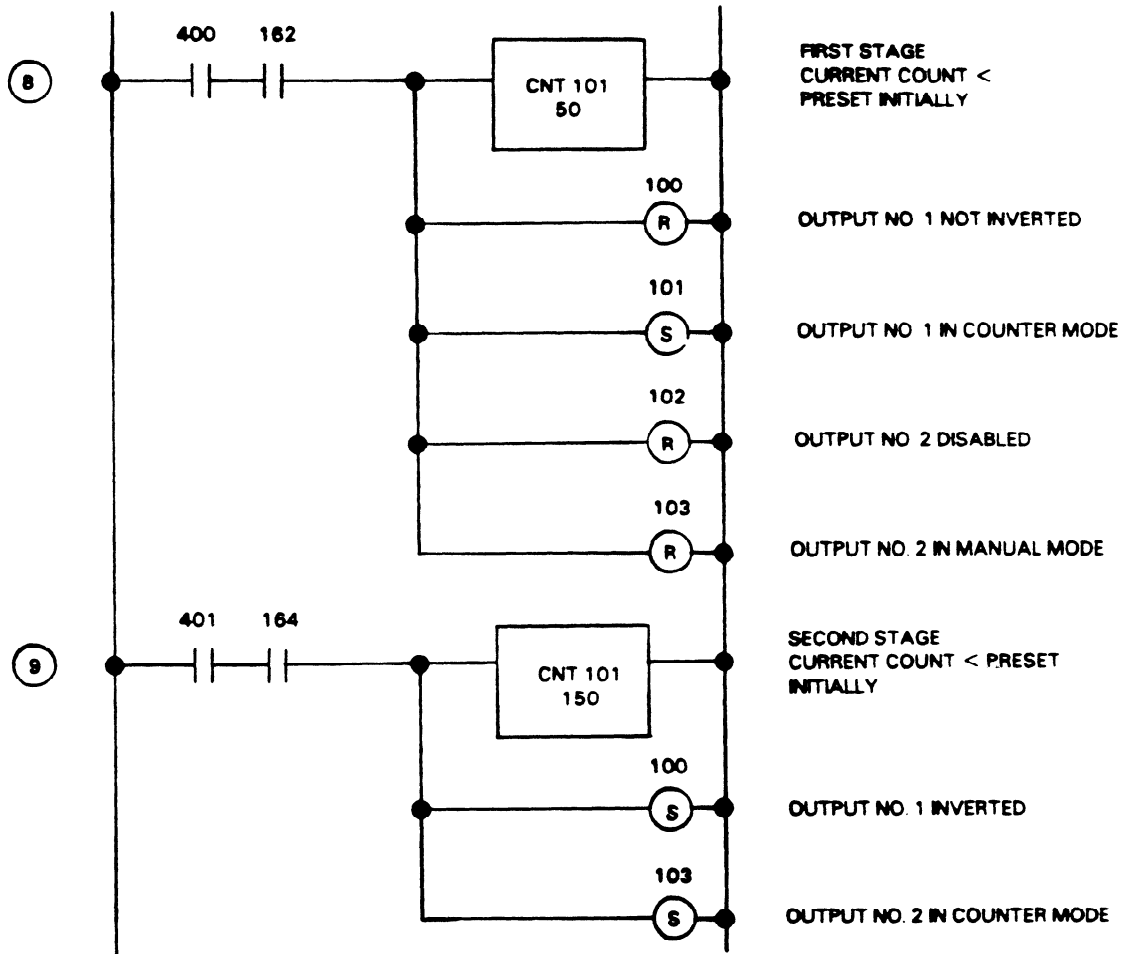

Figure 8-15 Programmable CAM Switch (Continued)

GEK-90842

Cut to Length

With this type of control application the object is to generate a pulse output every X number of counts. In cut to length applications X represents the length of material to be cut in pulses from the encoder. The following example pulses output No. 1 of the High Speed Counter once every 100 counts. The figure below shows the logic diagram for output No. 1, while the next figure contains the wiring diagram for this type of application, followed by the associated ladder logic.

a40894

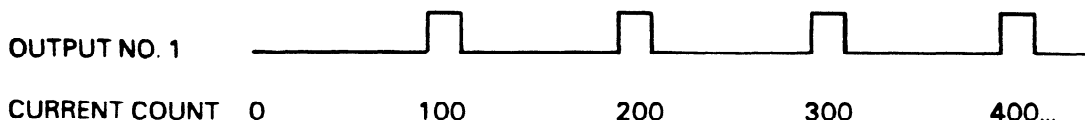

Figure 8-16. Output No. 1 Logic Diagram

pc-s1-84-0014

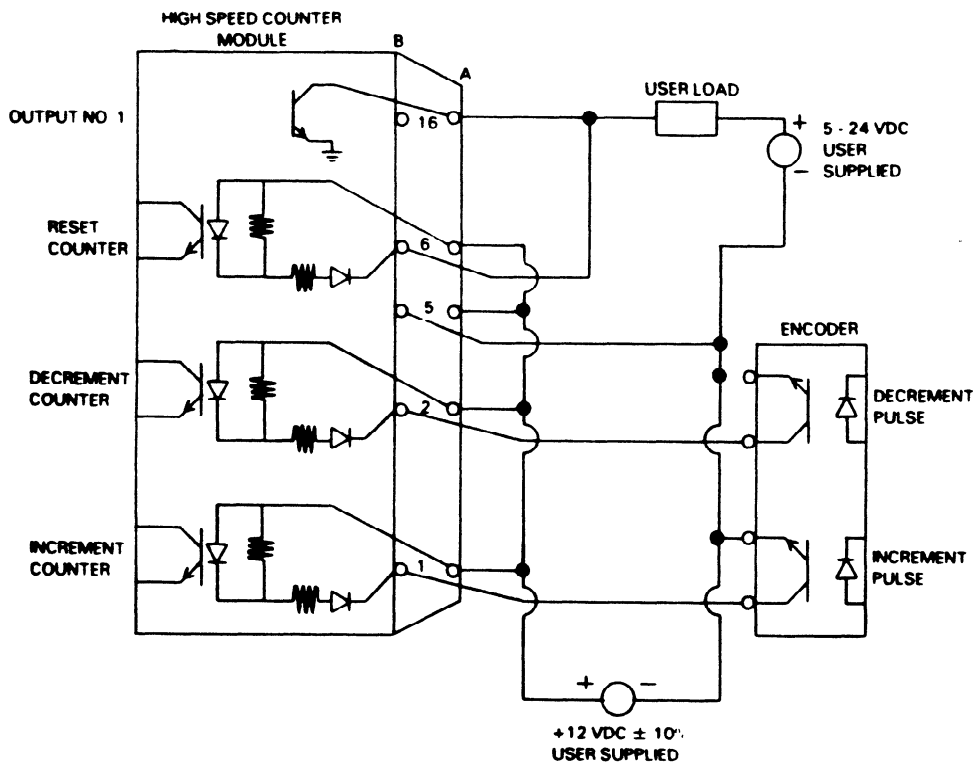

Figure 8-17. Wiring Diagram

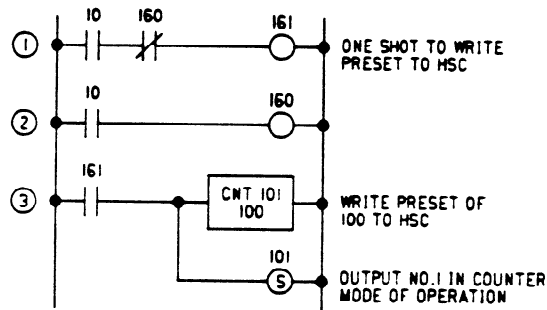

Figure 8-18. Cut to Length Program

Measuring a Random Length

In measuring the length of moving objects, the leading and trailing edge of the object enables and disables the counter which is tied to the encoder. At this point the accumulate value of the counter represents the length of the object. Unfortunately the accumulate value of the High Speed Counter cannot be moved into the user logic of a Series One or Series One Plus PC. Thus an objects length can only be measured relative ($> = <$) to a preset value in the counter. Through the use of a shift register and multiple presets, the length can be approximated to within two successive presets. To determine the accuracy a moving objects length can be measured. Three parameters must be considered:

1. Velocity of Object (pulses/second)
2. Resolution of Encoder (inches/pulse)
3. Scan time of the Series One or Series One Plus CPU (seconds) These three factors combine in the following manner to determine the accuracy of measurement.

$$\text{Accuracy of Measurement} = R \frac{\text{INCH}}{\text{PULSE}} \frac{V \text{ PULSE}}{\text{SEC}} 1.1\text{sc (sec)}$$

GEK-90842

Sample Calculation

Given:

1. 0.1 inches/pulse
2. 60 RPM, assume 1 pulse/degree = 360 pulses/second
3. Scan time 20 msec

PULSE SEC

The user logic as shown would implement this type of measurement giving a resolution of 10 counts.

I/O Definition: I11 - Photoelectric cell which enables counter I10 - Manual Reset/Initialize

a40895

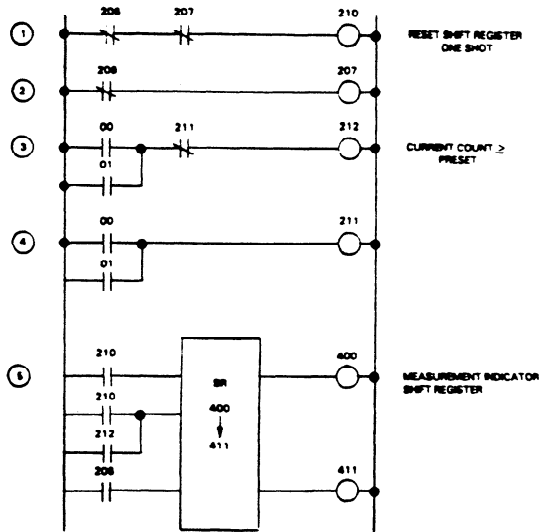

Figure 8-19. Measuring a Random Length

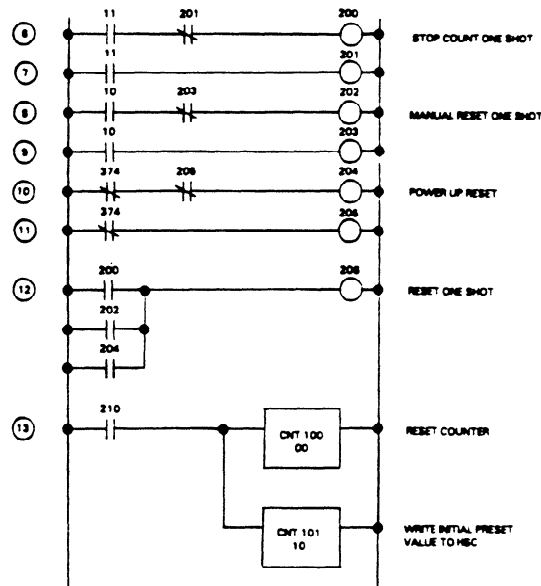

Figure 8-19 Measuring a Random Length(Continued)

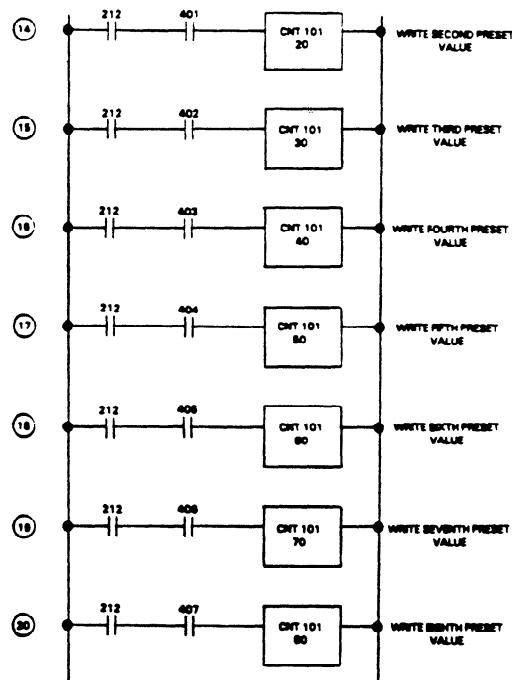

Figure 8-19 Measuring a Random Length(Continued)

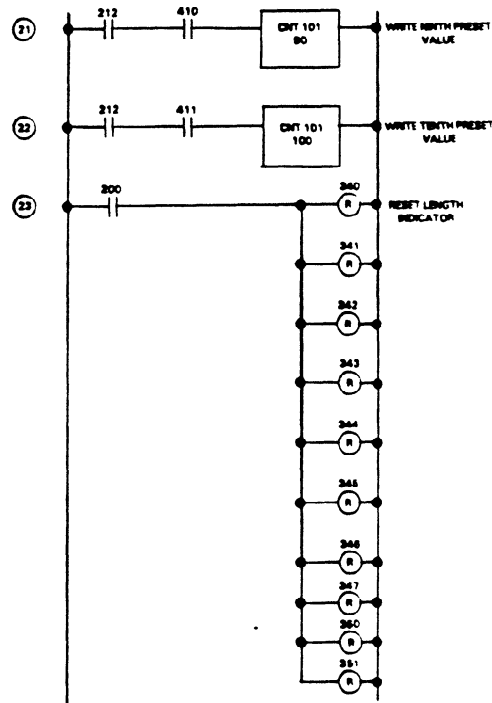

Figure 8-19 Measuring a Random Length(Continued)

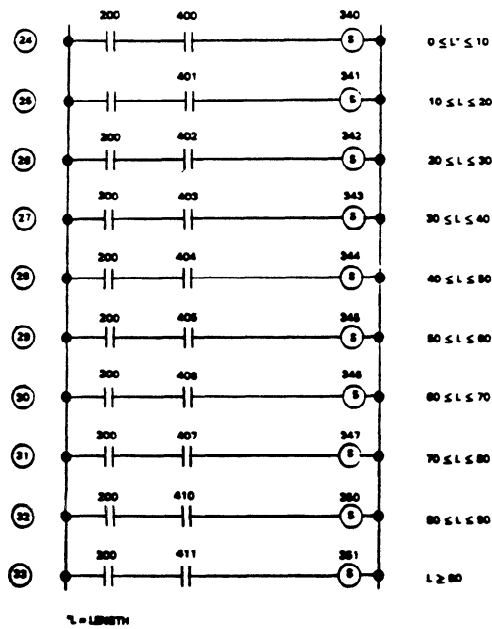

Figure 8-19 Measuring a Random Length(Continued)

Application 9 - Typical Shift Registers

When applying controls to a conveyor system or indexing machine, consideration must be given to the object being assembled, since it invariably has discrete information (pass, fail, etc.) associated with it. Each time that the object is advanced in the assembly process, its discrete information must follow it. The shift register function provides this control within the Series One and Series One Plus PCs.

Referring to the following example, the objects undergo a mechanical and visual inspection at stations Number 1 and 3. If either inspection fails, the object is rejected at station Number 5. In order to track the pass or fail status of each object, two shift registers are required, one for the mechanical inspection and one for the visual inspection.

pc-s1-83-0044

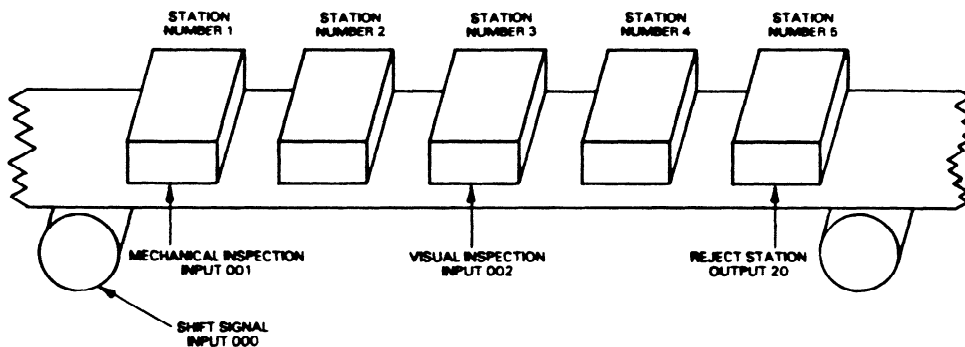

Figure 8-20. Shift Register Example

In this example, I/O and shift register references are assigned as follows:

INPUTS		OUTPUTS	
00	Advance belt, shift signal	20	Reject Arm
			0 - Off
			1 - On
01	Mechanical inspection		
	0 - pass		
	1 - fail		
02	Visual inspection		
	0 - pass		
	1 - fail		
03	Reset Shift Register		

GEK-90842

Shift Register References

- 400 First reference in mechanical inspection shift register.
- 401 Second reference in mechanical inspection shift register.
- 402 Third reference in mechanical inspection shift register.
- 403 Fourth reference in mechanical inspection shift register
- 410 First reference in visual inspection shift register.
- 411 Second reference in visual inspection shift register.

Typical logic using these references is shown in the following ladder diagram.

pc-s1-83-0045

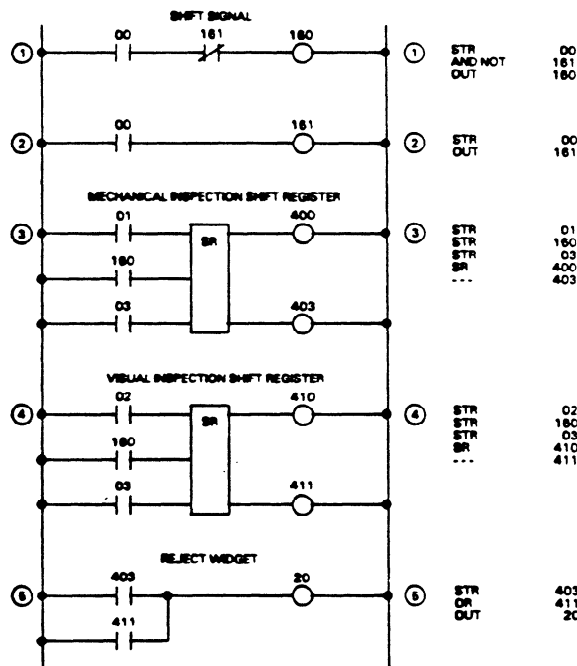

Figure 8-21. Typical Shift Register Logic

Appendix A

Related Documentation

Introduction

Several manuals are available that complement this manual. These manuals provide information required to fully implement certain features and options available for use with a Series One or One Plus programmable controller system. A basic description of the content of these manuals is provided in this appendix. The following manuals are available and along with this manual, constitute a complete set of documentation for a Series One or Series One Plus PC system.

GEK-90477 Series One/Three Data Communications Manual
GEK-90507 Remote I/O User's Manual
GEK-90825 Series Six PC I/O Link Local Module User's Manual
GEK-90846 Portable Programmer User's manual
GEK-96632 Logicmaster 1 Programmer Documentor Manual
GFK-0075 Logicmaster 1 Family Programming and Documentation Software

GEK-90477 Series One/Three Data Communications Manual

This manual provides information necessary to implement a serial communications link between a Series Six or Series Six Plus programmable controller (PC) or host computer and a Series One, Series One Plus, Series One Junior, or Series Three PC.

You should become familiar with the operation of the Series One, Series One Plus, Series One Junior, or Series Three PC (depending on your application) before reading this manual. Also, if a Series Six or Series Six Plus PC is to be included in your communications link, you may wish to refer to the Series Six Data Communications Manual, GEK-25364, for relevant information.

Chapter 1, Introduction, describes the capabilities of the Data Communications Unit (DCU) and the Data Communications Module (DCM) and possible system configurations of Series One, Series One Plus, Series One Junior, and Series Three PCs with a Series Six or Series Six Plus PC or host computer.

Chapter 2, Installation and Operation of the Data Communications Unit for the Series One, Series One Plus, and Series One Junior PCs, describes the operation of the Data Communication Unit's user interfaces and the installation of the DCU.

Chapter 3, Installation and operation of the Data Communications Module for the Series Three PC, describes the operation of the Data Communication Module's user interfaces and the installation of the DCM.

Chapter 4, Electrical Interface Circuits, provides the information needed to construct cables to connect the DCU or DCM to other devices.

Chapter 5, Communications Examples, explains how to build the Series Six ladder diagram to initiate communications between a Series Six or Series Six Plus PC and a Series One, Series One Plus, Series One Junior, or Series Three PC.

Chapter 6, Serial Interface Protocol, provides complete reference information on DCU and DCM serial interface protocol and timing to allow the user to write a serial communications driver for a host computer or microprocessor.

GEK-90507 Remote I/O User's Manual

This manual provides information needed to implement a Remote I/O system using the I/O of Series One and Series Three PCs.

Chapter 1, Introduction to Remote I/O, is a general description of the capabilities of Series One and Series Three PCs.

Chapter 2, Installation and wiring of the I/O Link modules, discusses the hardware used, installation, wiring, and fault detection.

Chapter 3, Configuring a Remote I/O system for the Series One PC, describes how to design and implement a Series One Remote I/O system.

Chapter 4, Configuring a Remote I/O system for the Series Three PC, describes how to design and implement a Series Three Remote I/O system.

Chapter 5, Configuring Mixed Remote I/O systems, describes how to design and implement a mixed (Series One and Series Three) Remote I/O system.

Chapter 6, Timing Considerations, explains how to determine the timing delays in the Remote I/O structure.

Appendix A, Power Supply Loading, lists the power characteristics of the power supplies and modules used in Series One and Series Three PCs.

Appendix B, Design Worksheets, contains handy worksheets for designing Remote I/O systems.

GEK-90825 Series Six PC I/O Link Local Module User's Manual

This manual describes the link between the Series Six family of programmable controllers and the I/O structure for the Series One and Series Three programmable controllers. This link is established between the Series Six I/O Link Local module and the Series One family and Series Three I/O Link Remote modules.

Chapter 1, Connecting the Series Six PC to the Series One or Series Three I/O system, is an overview of the system configuration and operation.

Chapter 2, Series Six PC I/O Link Local Module and Programming, explains how to install and operate the Series Six I/O Link Local module and how to program the Series Six CPU for I/O Link Local operations.

Chapter 3, Series One PC I/O Link Remote Module, explains the installation and operation of the Series One PC I/O Link Remote module.

Chapter 4, Series Three PC I/O Link Remote Module, explains the installation and operation of the Series Three PC I/O Link Remote module.

Chapter 5, Cable Wiring, describes cable wiring between the Series Six PC I/O Link Local module and the Series One or Series Three PC I/O Link Remote module.

Appendices A, B, and C, provide application information on setting up an example I/O chain and using the I/O chain status byte.

GEK-90846 Portable Programmer User's Manual

The purpose of this manual is to provide information on the functions and features of the Portable Programmer and to instruct the user in installing, programming, and implementing the Portable

GEK-90842

Programmer with the Series One programmable controller family and the Series Three programmable controller.

This manual contains nine chapters and six appendices. Each chapter contains sections to aid the user in locating required information.

Chapter 1, Product Summary, presents a product overview and describes the operating modes.

Chapter 2, Operation, explains the installation and operation of the portable Programmer.

Chapter 3, Introduction to Programming, provides general information on programming.

Chapter 4, Definition and Entry of Instructions, explains how to start a new program and contains the instruction sets.

Chapter 5, Edit Program, provides instructions for entering the Edit mode and editing functions.

Chapter 6, Display Program, provides the user with the information for displaying a ladder logic program.

Chapter 7, On-Line Monitor/Change, covers the On-Line Monitor and On-Line Change functions available for the Series One Plus and Series Three PCs.

Chapter 8, Communications, explains how programs may be stored on cassette tapes or transferred to the PCs.

Chapter 9, Print, covers the print options and functions.

Appendix A, Series One PC Serial Interface Setup, covers the Data Communications Unit and the CPU serial cable.

Appendix B, Series Three PC Serial Interface Setup, contains information needed for connecting a Series Three PC with the Portable Programmer.

Appendix C, Port Definition, describes the CPU serial port and the printer port.

Appendix D, Compatible Printers, contains the necessary information to implement and specifications for selection of compatible printers.

Appendix E, Series One Plus PC Password, contains instructions for password operation.

Appendix F, Portable Programmer Case, illustrates optional carrying case for the Portable Programmer.

GEK-96662 Logicmaster 1 Programmer Documentor Manual

This manual presents the information necessary to use the Workmaster industrial computer with the Logicmaster 1 application software to program a Series One PC. The information contained in this manual corresponds to version 02.01 of the Logicmaster 1 Programming and Documentation Software.

Chapter 1, Introduction, introduces the capabilities of the Logicmaster 1 software and also explains how to load and copy it.

Chapter 2, Workmaster Operation Using Logicmaster 1 Software, explains basic operation of the Workmaster industrial computer when using Logicmaster 1 software. Sections are included on the keyboard, display format, and keyswitch positions for the Workmaster computer and Series One PC.

Chapter 3, Programming the Series One PC, explains how to enter programming logic for the Series One PC through the Edit Program function.

Chapter 4, Advanced Programming Functions, explains how to annotate Series One programs and how to use the Teach function to make programming on the Workmaster computer easier.

Chapter 5, Logicmaster 1 System Functions, explains how to use the scratch pad, print programs, upload and download programs, and use the filing programs.

Appendix A, Menu Tree for Logicmaster 1 Software, provides a map to the function keys throughout the Logicmaster 1 software.

Appendix B, Port Characteristics and Wiring Diagrams, provides the information needed to connect the Workmaster computer to the Series One PC or peripherals such as an external disk drive or printer.

GFK-0075 Logicmaster 1 Family Programming and Documentation Software User's Manual

This manual provides the information necessary to use the Workmaster® and Cimstar I™ industrial computers with Logicmaster 1 Family application software to program the Series One Model E, Series One Plus, and Series One Plus 3.7K Programmable Controllers. The content of this manual is arranged similarly to GEK-96662, as described above.

Appendix B

Glossary of Terms

- Address** - A series of numbers from 0 to 1723 in the Series One and Series One Plus Programmable Controllers, assigned to specific program memory locations and used to access those locations.
- AND** - (Logical) A mathematical operation between bits, whereby all bits must be a 1 in order for the result to be a 1.
- AND** - (Function) An operation that places two contacts or groups of contacts in series. Both control the resultant status.
- BCD (Binary Coded Decimal)** - A 4-bit system in which individual decimal digits (0 through 9) are represented by 4-bit binary numerals; for example, the number 43 is represented by 0100(4) 0011(3) in the BCD notation.
- Bit** - The smallest unit of memory. Can be used to store only one piece of information having more than one state (for example, a one/zero, ON/OFF, good/bad, yes/no, etc). Data that requires more than two states (e.g. numerical values 000-999) will require multiple bits.
- Byte** - A measurement of memory, in the Series One and Series One Plus, equal to 8 bits.
- CMOS** - Acronym for Complimentary Metal-Oxide Semiconductor. A read/write memory that requires a battery to retain its content upon loss of power.
- CPU (Central Processing Unit)** - The central device or controller that interprets user instructions, makes decisions and executes the functions based on a stored program. This program specifies actions to be taken to all possible inputs.
- Counter** - A function within the PC that records events based upon the on/off transition of a signal. A coil associated with the counter is energized at a user determined preset value.
- Field Devices** - User supplied devices typically providing information to the PC (Inputs: pushbutton, limitswitches, relay contacts, etc.) or performing PC tasks (Outputs: motor starters, solenoids, indicator lights, etc.).
- Group** - A series of eight consecutive references, such as I/O points, internal coils, etc.
- Inputs** - A signal, typically ON or OFF, that provides information to the PC.
- Instruction** - A word, usually an acronym, or group of words and numerals that are part of a program entered into user memory.
- I/O (Input/Output)** - That portion of the PC to which field devices are connected. Isolates the CPU from electrical noise.
- I/O Scan** - A method by which the CPU monitors all inputs and controls all outputs within a prescribed time.
- K** - An abbreviation for kilo or exactly 1024 in the world of computers. Usually related to 1024 words of memory.
- Ladder Diagram** - A representation of control logic relay systems. The user programmed logic is expressed in relay equivalent symbology.
- Latch** - A PC operation that causes a coil to stay on and remain on even if power or the input is removed. Referred to as a retentive function.

- Logic** - A fixed set of responses (outputs) to various external conditions (inputs). All possible situations for both synchronous and non-synchronous activity must be specified by the user. Also referred to as the program.
- Memory** - a physical place to store information such as programs and/or data.
- Microsecond (ms)** - One millionth of a second. 1×10^{-6} or 0.000001 second.
- Millisecond (ms)** - One thousandth of a second. 1×10^{-3} or 0.001 second.
- Modules** - A replaceable electronic subassembly usually plugged in and secured in place but easily removable in case of fault or system redesign.
- Noise** - Undesirable electrical disturbances to normal signals generally of high frequency content.
- Non-Retentive Coil** - A coil that will turn off when power is removed.
- Optical Isolation** - Use of a solid state device to isolate the user input and output devices from internal circuitry of an I/O module and the CPU.
- OR** - (Logical) A mathematical operation between bits, whereby if any bit is a 1, the result will be a 1.
- OR** - (Function) An operation that places two contacts or groups of contacts in parallel. Either controls the resultant status.
- Outputs** - A signal typically ON or OFF, originating from the PC with user supplied power that controls external devices based upon commands from the CPU.
- PC or PLC** - See Programmable Controller.
- Peripheral Equipment** - External units that can communicate with a PC; for example, cassette tape recorder, Printer Interface Unit or PROM Writer Unit.
- Preset** - A numerical value specified in a function which establishes a limit for a counter or timer. A coil will energize when this value is reached.
- Program** - A sequence of functions and/or instructions entered into a Programmable Controller to be executed by the CPU for the purpose of controlling a machine or process.
- Programmable Controller** - A solid-state industrial control device which receives inputs from user supplied control devices such as switches and sensors, implements them in a precise pattern determined by ladder diagram based programs stored in the user memory, and provides outputs for control of user supplied devices such as relays and motor starters.
- Programmer** - A device for entry, examination and alteration of the PC's memory including logic and storage areas.
- PROM** - Acronym for Programmable Read Only Memory. A type of memory that requires a special method of loading, but is retentive upon power loss.
- RAM** - An acronym for Random Access Memory. A solid-state memory that allows individual bits to be stored and accessed. This type of memory is volatile; that is, stored data is lost under no power conditions, therefore a battery backup is required.
- Read** - To have data entered into a PC from a peripheral unit.
- Reference** - A number used in a program that tells the CPU where data is coming from or where to transfer the data.
- Register** - A group of consecutive memory locations within a PC, used for storage of numerical data.
- Retentive Coil** - A coil that will remain in its last state, even though power has been removed.

GEK-90842

Rung - A sequence or grouping of PC functions and instructions that control one coil. One or more rungs form a ladder diagram.

Scan - The technique of examining or solving all logic steps specified by the program in a sequential, repetitive order from the first step to the last.

Thumbwheel Switch - A rotating numeric switch which can be used for inputting numeric data to a PC.

Unlatch - A PC function that causes an output previously turned on by a latch function to turn off no matter how briefly the function is enabled.

Word - A measurement of memory, in the Series One and Series One Plus, equal to 16 bits.

Write - To output or transfer data from the PC to a peripheral unit.

Appendix C

Series One Family of Programmable Controllers Compatibility Guide

Feature	Junior	One™	Model E	Plus	Plus 3.7K
I/O Points (maximum)	24 Basic Unit 50 W/Exp Unit 96 W/Exp Rack	112	112	168	168
Memory					
Memory, 700 words CMOS RAM	standard	standard	standard	standard	n/a
Memory, Expand to 1724 words	no	yes (1)	yes (1)	yes (1)	n/a
Memory, 3700 words CMOS	no	no	no	no	yes
RAM					
EPROM, non-volatile storage	yes (2)	yes (2)	yes (2)	yes (2)	yes (2)
Battery Back-Up	yes	yes	yes	yes	yes
Typical Scan 0.5 K Program:	20 mSec	20 mSec	8 mSec	8 mSec	8 mSec
Times 1.0 K Program:	40 mSec	40 mSec	12 mSec	12 mSec	12 mSec
1.7 K Program:	n/a	65 mSec	15 mSec	15 mSec	15 mSec
3.7 K Program:	n/a	n/a	n/a	n/a	36 mSec
Internal Functions	160	144	144	144	144
Non-Retentive Coils	96	112	112	112	112
Retentive Coils	59	28	28	28	28
Special Function Coils	5	4	4	4	4
Timers/Counters	20 (4-digit)	64 (4-digit)	64 (4-digit)	64 (4-digit)	64 (4-digit)
Thumbwheel Interface Module	no	yes	yes (3)	yes (3)	yes (3)
Timer/Counter Setpoint Unit	yes	no	yes (3)	yes (3)	yes (3)
Shift Registers	155 steps	128 steps	128 steps	128 steps	128 steps
Data Registers (12)	no	no	no	64 (16-bit)	64 (16-bit)
Sequencers	20 (1000 step)	64 (1000 step)	64 (1000 step)	64 (1000 step)	64 (1000 step)
High Speed Counter					
Built-In (2 KHz)	yes	no	no	no	no
I/O Module (10 KHz)	no	yes	yes	yes	yes
Discrete I/O Modules	yes (4, 5, 6)	yes	yes	yes	yes
Analog I/O Modules	yes (4, 7)	yes (7)	yes (7)	yes	yes
UL Listed Modules	yes	yes	yes	yes	yes
Remote I/O	yes (9)	yes (8)	yes (8)	yes (8)	yes (8)
No. of I/O in Remote System	26, 40 or 72	96	96	96	96
Programming Language					
Basic Ladder Diag. Functions	yes	yes	yes	yes	yes
Data Operations and Math	no	no	no	yes	yes
Program W/Hand-Held Programmer					
IC610PRG100	yes	yes	yes	yes (11)	yes (11)
IC610PRG105	yes	yes	yes	yes	yes
Hand-Held Prog Mount Assembly	yes	yes	yes	yes	yes

1. CMOS RAM memory
Series One, 6116LP, Series One Plus, 6264LP-15 (low power devices only)
2. EPROM memory
Series One Junior & Series One, 2732
Series One Plus, 27256-25
Series One Plus 3.7K, 27256-25
3. One Thumbwheel Interface or one Timer/Counter Setpoint Unit can be used in a system, not both
4. Requires Series One 5 or 10-slot expansion rack.
5. Limited to one 16-point module per system.
6. See I/O Module Compatibility Chart
7. Has limited usefulness
8. Remote I/O stations can be located up to 3300' (1Km) from the CPU, connected by twisted-pair cable to I/O Link Local and I/O Link Remote modules.
9. Expansion rack can be 100' (30m) from basic unit, connected through an I/O Expansion cable to a basic unit and an I/O Expansion module in the Expansion rack.
10. Applies to Series One Junior only.
11. PRG 100 cannot access data registers, data operations, or math.
12. Up to 124 total if unused Timer/Counter references used as data registers.

Feature	Junior	One™	Model E	Plus	Plus 3.7K
Program with Workmaster® Computer or IBM Personal Computer	(1)	yes	yes	yes	yes
Program with LCD Port. Programmer CPU	yes	yes	yes	yes	yes
IC610CPU101 (UL Listed)	n/a	yes	no	no	no
IC610CPU104	n/a	no	yes	no	no
IC610CPU105	n/a	no	no	yes	no
IC610CPU106	n/a	no	no	no	yes
Password Protection Available	no	no	yes	yes	yes
Racks					
5-slot, IC610CHS101 (2)(6)	no	yes	yes	yes	yes
5-slot, IC610CHS110 (2)	yes(expansion)	yes	yes	yes	yes
5-slot, IC610CHS111 (5)	yes(expansion)	yes	yes	yes	yes
5-slot, IC610CHS114 (3)	yes(expansion)	yes	yes	yes	yes
10-slot, IC610CHS130 (2)	yes(expansion)	yes	yes	yes	yes
10-slot, IC610CHS134 (3)	yes(expansion)	yes	yes	yes	yes
19" Rack Mounting Brackets	yes (4)	yes (4)	yes (4)	yes (4)	yes (4)
Data Communications Unit, CCM100	yes	yes	no	no	no
Data Communications Unit, CCM105	yes	yes	yes	yes	yes Rev C
RS-232/422 Adaptor Unit	yes	yes	yes	yes	yes
Peripheral Devices					
Printer Interface Unit Rev C	yes Rev A & B	yes Rev A & B	yes Rev B	yes Rev B	yes
PROM Writer Unit	yes Rev A & B	yes Rev A & B	yes Rev B	yes Rev B	yes Rev C
Timer/Counter Setpoint Unit	yes	no	yes	yes	yes
Cassette Tape Recorder	yes	yes	yes	yes	yes
Accessory Kit	included	yes	yes	yes	yes

1. Future enhancement with this product.
2. Requires 115/230 V ac power source.
3. Requires 24 V dc power source.
4. Used with 10-slot rack.
5. UL Listed, 115 V ac power source only.
6. Not expandable

GENERAL SPECIFICATIONS

Humidity	5% to 95% (non-condensing)
Typical Battery Life	
Operating	2 to 5 Years
Shelf Life	8 to 10 Years
Operating Power For	115/230 V ac
Series One Junior Basic	24 V dc
Units and all Racks	See specifications for each unit or rack for details

GEK-90842

Table C-1. I/O Module Capability/Compatibility Guide

Feature	Junior	One™	Model E	Plus	Plus 3.7K
Input Modules					
IC610MDL125 115 V ac, 8 Circuits	yes (1)	yes	yes	yes	yes
IC610MDL127 230 V ac, 8 Circuits	yes (1)	yes	yes	yes	yes
IC610MDL126 115 V ac Isolated, 4 Circuits	yes (1)	yes	yes	yes	yes
IC610MDL101 24 V dc Sink, 8 Circuits	yes (1)	yes	yes	yes	yes
IC610MDL107 24 V dc Sink Load, 16 Circuits	yes (1)	yes	yes	yes	yes
IC610MDL106 24 V dc Sink, 16 Circuits	yes (1)	yes	yes	yes	yes
IC610MDL111 24 V ac/dc Source, 8 Circuits	yes (1)	yes	yes	yes	yes
IC610MDL112 24 V ac/dc Source, 16 Circuits	yes (1)	yes	yes	yes	yes
IC610MDL116 Analog Input, yes (1)	yes	yes	yes	yes	
IC610MDL135 (UL Listed) 115 V ac Input, 6 Circuits	yes (1)	yes	yes	yes	yes
Output Modules					
IC610MDL175 115/230 V ac, 8 Circuits	yes (1)	yes	yes	yes	yes
IC610MDL176 115/230 V ac Isolated, 4 Circuits	yes (1)	yes	yes	yes	yes
IC610MDL151 24 V dc Sink, 8 Circuits	yes (1)	yes	yes	yes	yes
IC610MDL156 24 V dc Sink, 16 Circuits	yes (1)	yes	yes	yes	yes
IC610MDL153 24 V dc 2 A Sink, 4 Circuits	yes (1)	yes	yes	yes	yes
IC610MDL154 24 V dc 2 A Sink/Source, 4 Circuits	yes (1)	yes	yes	yes	yes
IC610MDL155 24 V dc Source, 8 Circuits	yes (1)	yes	yes	yes	yes
IC610MDL158 24 V dc Source, 16 Circuits	yes (1)	yes	yes	yes	yes
IC610MDL166 Analog Output	yes (1)	yes	yes	yes	yes
IC610MDL180 Relay Output, 8 Circuits	yes (1)	yes	yes	yes	yes
IC610MDL181 (UL Listed) Relay Output, 5 Circuits	yes (1)	yes	yes	yes	yes
IC610MDL182 Relay Output, 16 Circuits	yes (1)	yes	yes	yes	yes
IC610MDL185 (UL Listed) Relay Output, 8 Circuits	yes (1)	yes	yes	yes	yes
Special Modules					
IC610MDL103 24 V dc In/Out, 4 In/4 Out	yes (1)	yes	yes	yes	yes
IC610MDL104 24 V dc Sink In/Rly Out, 4 In/4 Out	yes (1)	yes	yes	yes	yes
IC610MDL115 Fast Response I/O, 4 In/2 Out	yes (1)	yes	yes	yes	yes
IC610MDL124 I/O Simulator, 8 Input Circuits	yes (1)	yes	yes	yes	yes
IC609TCU100 Timer/Counter Setpoint Unit	yes (1)	no	yes (2)	yes (2)	yes (2)
IC610MDL105 Thumbwheel Interface	no	yes	yes (2)	yes (2)	yes (2)
IC610MDL110 High Speed Counter	no	yes	yes	yes	yes

1. Requires a 5 or 10-slot expansion rack.

2. One Thumbwheel Interface or one Timer/Counter Setpoint unit can be used in a Series One Plus system, not both.

**Table C-2. Summary of Programming References for Series One Family
of Programmable Controllers**

Memory Type	Valid References (Octal)	Decimal Quantity
Series One Junior		
I/O Points		96 total
Basic Unit Inputs	000-016	15
Basic Unit Outputs	017-027	9
I/O Expansion Unit Inputs	030-047	16
I/O Expansion Unit Outputs	058-061	10
Expansion Rack I/O	030-067 130-137	40
Internal Coils		160 total
Non-Retentive	140-277	96
Retentive	300-372	59
Set Retentive Coils	373	1
First Scan Reset	374	1
0.1 Second Clock	375	1
Disable All Outputs	376	1
Back-Up Battery Status	377	1
Shift Register	140-372	155 (total steps)
Timers and Counters	600-623	20 (4 digit) (1)
High Speed Counter	624	1
Sequencers	600-623	20 (1000 step)
Series One/Series One Model E		
I/O points	000-157	112 total
Internal Coils		144 total
Non-Retentive	160-337	112
Retentive Coils	340-373	28
Initial Reset	374	1
0.1 Second Clock	375	1
Disable All Outputs	376	1
Back-Up Battery Status	377	1
Shift Registers	400-577	128 steps
Timer/Counters	600-677	64 (1)
Sequencers	600-677	64 (1000 steps)
Series One Plus/Series One Plus 3.7K		
I/O points	000-157	168 total
Internal Coils	700-767	144 total
Non-Retentive	160-337	112
Retentive Coils	340-373	28
Initial Reset	374	1
0.1 Second Clock	375	1
Disable All Outputs	376	1
Back-Up Battery Status	377	1
Special Purpose Coils	8	
Shift Registers	400-577 (2)	128 steps
Timer/Counters	600-677	64 (1)
Sequencers	600-677	64 (1000 steps)
Data Registers	400-577 (2)	64 (16-bit)
<ol style="list-style-type: none"> Total maximum number of Timers and/or Counters. Although shift registers and data register references are the same, shift registers operate on individual bits, while data registers operate on bytes in a totally different area of memory. Unused T/C references can be used as data registers which provides up to 124 16-bit data registers (T/C references 674-677 are reserved for T/C use only). 		

GEK-90842

Table C-3. Programming Function Compatibility Guide

Feature	Junior	One™	Model E	Plus	Plus 3.7K
Basic Ladder Diagram Functions					
STR, STR NOT	yes	yes	yes	yes	yes
AND, AND NOT	yes	yes	yes	yes	yes
OR, OR NOT	yes	yes	yes	yes	yes
SET, RST	yes	yes	yes	yes	yes
OUT	yes	yes	yes	yes	yes
SET OUT	yes	yes	yes	yes	yes
SET OUT RST	no	no	no	yes	yes
OR STR	yes	yes	yes	yes	yes
MCS, MCR	yes	yes	yes	yes	yes
TMR	yes	yes	yes	yes	yes
STR TMR	yes	yes	yes	yes	yes
STR NOT TMR	yes	yes	yes	yes	yes
AND TMR	yes	yes	yes	yes	yes
AND NOT TMR	yes	yes	yes	yes	yes
OR TMR	yes	yes	yes	yes	yes
OR NOT TRM	yes	yes	yes	yes	yes
CNT	yes	yes	yes	yes	yes
STR CNT	yes	yes	yes	yes	yes
STR NOT CNT	yes	yes	yes	yes	yes
AND CNT	yes	yes	yes	yes	yes
AND NOT CNT	yes	yes	yes	yes	yes
OR CNT	yes	yes	yes	yes	yes
OR NOT CNT	yes	yes	yes	yes	yes
SR	yes	yes	yes	yes	yes
Data Operations					
D•STR (Data Store)	no	no	no	yes	yes
D•STR1	no	no	no	yes	yes
D•STR2	no	no	no	yes	yes
D•STR3	no	no	no	yes	yes
D•STR5	no	no	no	yes	yes
D•OUT (Data Out)	no	no	no	yes	yes
D•OUT1	no	no	no	yes	yes
D•OUT2	no	no	no	yes	yes
D•OUT3	no	no	no	yes	yes
D•OUT5	no	no	no	yes	yes
COMPARE	no	no	no	yes	yes
ADD	no	no	no	yes	yes
SUBTRACT	no	no	no	yes	yes
MULTIPLY	no	no	no	yes	yes
DIVIDE	no	no	no	yes	yes
D•AND (Logical AND)	no	no	no	yes	yes
D•OR (Logical OR)	no	no	no	yes	yes
INVERT	no	no	no	yes	yes
BIN (BCD To Binary Convert)	no	no	no	yes	yes
BCD (Binary To BCD Convert)	no	no	no	yes	yes
SHIFT RIGHT	no	no	no	yes	yes
SHIFT LEFT	no	no	no	yes	yes
DECODE	no	no	no	yes	yes
ENCODE	no	no	no	yes	yes
EXTERNAL FAULT DIAGNOSIS	no	no	no	yes	yes

Table C-4. Examples of Valid System Configurations for I/O Points

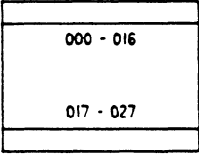
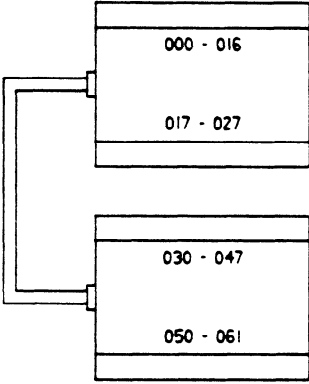
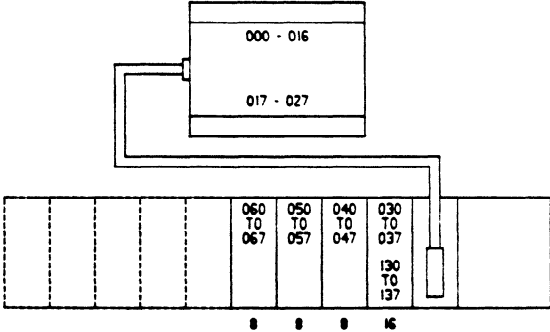
I/O Points	PC and Rack Type	I/O Module Type	Valid Configuration and References
24	Series One Junior IC609SJR100 IC609SJR102 IC609SJR110 IC609SJR114 IC609SJR120 IC609SJR124 IC609SJR121	Basic Unit Inputs - 15 Outputs - 9	TPK.A.40896 
50	Series One Junior IC609SJR100 IC609SJR102 IC609SJR110 IC609SJR114 IC609SJR120 IC609SJR124 IC609SJR121 I/O Expansion Units IC609EXP110 IC609EXP120 IC609EXP121	Basic Unit Inputs - 15 Outputs - 9 I/O Expansion Inputs - 16 Outputs - 10	TPK.A.41931 
64	Series One Junior IC609SJR100,102 IC609SJR110, 114 IC609SJR120, 124 IC609SJR121 And One Expansion Rack 5 or 10-Slot Rack IC610CHS110, 114 IC610CHS130, 134 IC610CHS120, 124	Basic Unit Inputs - 15 Outputs - 9 24 I/O (3) 8-Point (1) 16-Point 40 I/O	TPK.A.40897 

GEK-90842

Table C-4. Examples of Valid System Configurations for I/O Points - Continued

I/O Points	PC and Rack Type	I/O Module Type	Valid Configuration and References
96	Series One Junior IC609SJR100, 102 IC609SJR110, 114 IC609SJR120, 124 IC609SJR121 And One Expansion Rack 10-Slot Rack IC610CHS130, 134 IC610CHS120, 124	Basic Unit Inputs - 15 Outputs - 9 24 I/O 72 I/O (7) 8-Point (1) 16-Point or (9) 8-Point	TPK.A.41932 <p>The diagram shows a basic unit (000-016) connected to an expansion rack. The rack has 10 slots. The first slot is a blank expansion rack. Slots 2-6 contain modules for inputs: I2C TC I27, I1C TC I17, I0C TC I07, O7C TC O77, O6C TC O67, O5C TC O57, O4C TC O47, and O3C TC O37. Slots 7-9 contain modules for outputs: I3C TC I37, I2C TC I27, I1C TC I17, I0C TC I07, O7C TC O77, O6C TC O67, O5C TC O57, O4C TC O47, and O3C TC O37. Slot 10 is a blank expansion rack. Below the rack, there are labels '8 8 8 8 8 8 8 8 8 8' and 'OR'.</p>
32 64	Series One Series One Model E Series One Plus Series One Plus 3.7K (1) 5-Slot Rack IC610CHS110 IC610CHS114 IC610CHS101	(4) 8-Point Modules or (4) 16-Point Modules	TPK.A.40898 <p>The diagram shows a 5-slot rack. Slot 1 is a blank expansion rack. Slots 2-5 contain modules for inputs: I30 TC I37, I20 TC I27, I10 TC I17, and O00 TC O07. Slot 6 is a CPU module. Slot 7 is a blank expansion rack. Below the rack, there are labels '8 8 8 8' and '16 16 16 16'.</p>
64	Series One Series One Model E Series One Plus Series One Plus 3.7K (2) 5-Slot Racks IC610CHS110 IC610CHS114	(8) 8-Point Modules	TPK.A.41933 <p>The diagram shows two 5-slot racks connected. The top rack has slots 1-4 with modules for inputs: I30 TC I37, I20 TC I27, I10 TC I17, and O00 TC O07. Slot 5 is a CPU module. The bottom rack has slots 1-4 with modules for inputs: O7C TC O77, O6C TC O67, O5C TC O57, and O4C TC O47. Slot 5 is a blank expansion rack. Below the racks, there are labels '8 8 8 8'.</p>
64	Series One Series One Model E Series One Plus Series One Plus 3.7K (1) 10-Slot Rack IC610CHS130 IC610CHS134 IC610CHS120 IC610CHS124	(8) 8-Point or (4) 16-Point	TPK.A.41934 <p>The diagram shows a 10-slot rack. Slot 1 is a blank expansion rack. Slots 2-6 contain modules for inputs: O70 TC O77, O60 TC O67, O50 TC O57, O40 TC O47, O30 TC O37, O20 TC O27, O10 TC O17, and O00 TC O07. Slot 7 is a CPU module. Slots 8-10 are blank expansion racks. Below the rack, there are labels '8 8 8 8 8 8 8 8'.</p>

Table C-4. Examples of Valid System Configurations for I/O Points - Continued

I/O Points	PC and Rack Type	I/O Module Type	Valid Configuration and References
72	(9) 8-Point Series One Series One Model E Series One Plus	Modules	<div style="text-align: right;">TPK.A.40920</div>
112	Series One Plus 3.7K (1) 10-Slot Rack IC610CHS130 IC610CHS134 IC610CHS120 IC610CHS124	or (2) 8-Point Modules (6) 16-Point Modules	
			*Not used with 112 I/O Configuration
72	(9) 8-Point Series One Series One Model E Series One Plus	Modules	<div style="text-align: right;">TPK.A.40899</div>
112	Series One Plus 3.7K (2) 5-Slot Rack IC610CHS110 IC610CHS114	or (2) 8-Point Modules (6) 16-Point Modules	
112	Series One Plus 3.7K Series One Plus (1) 10-Slot Rack IC610CHS130, 134 And (1) 5-Slot Rack IC610CHS110, 114	(14) 8-Point Modules	<div style="text-align: right;">TPK.A.40922</div>
112	Series One Series One Model E Series One Plus Series One Plus 3.7K (3) 5-Slot Racks IC610CHS110 IC610CHS114	(14) 8-Point Modules	<div style="text-align: right;">TPK.A.40923</div>

GEK-90842

Table C-4. Examples of Valid System Configurations for I/O Points - Continued

I/O Points	PC and Rack Type	I/O Module Type	Valid Configuration and References
112	Series One Series One Model E (2) 10-Slot Racks IC610CHS130 IC610CHS134 IC610CHS120 IC610CHS124	(14) 8-Point Modules	TPK.A.41935 
120	Series One Plus Series One Plus 3.7K IC610CHS130 IC610CHS134	(6) 16-Point Modules And (3) 8-Point Modules	TPK.A.40924 
152	Series One Plus Series One Plus 3.7K (19) 8-Point IC610CHS130 IC610CHS134	Modules	TPK.A.41936 
160	Series One Plus Series One Plus 3.7K (1) 10-Slot Rack IC610CHS130, 134 And (1) 5-Slot Rack IC610CHS110, 114	(8) 8-Point Modules (6) 16-Point Modules	TPK.A.40925 

Table C-4. Examples of Valid System Configurations for I/O Points - Continued

I/O Points	PC and Rack Type	I/O Module Type	Valid Configuration and References
168	Series One Plus Series One Plus 3.7K (2) 10-Slot Racks IC610CHS130 IC610CHS134	(9) 8-Point Modules (6) 16-Point Modules	<div style="text-align: right;">TPK.A.40926</div>

1. These examples represent only a sampling of the many configurations of racks and I/O points that are available. Configurations depend on the number of I/O points and type of I/O modules (4, 8, or 16 points and the units of load used by the modules) required for a particular application.
2. If modules having only 4 I/O points are used in any slot, the references not used as "real world" I/O are available for use as internal references in the user program.
3. The 10-slot racks (IC610CHS130 and IC610CHS134) have 2 bridge connectors on the backplane which must be configured for proper rack addressing. Configuration of the bridge connectors is explained in chapter 3, Installation. The X in a slot means that there is no valid address for that slot for that configuration.

Appendix D Other Programmable Controllers

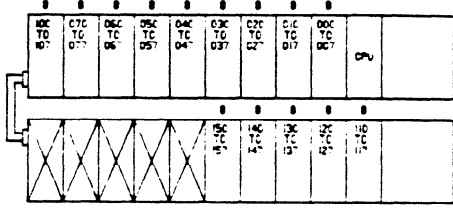
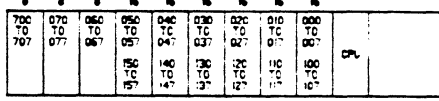
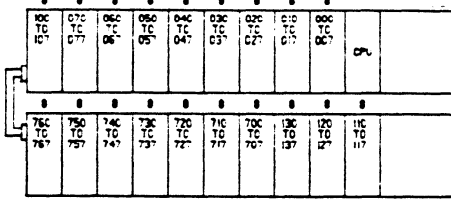
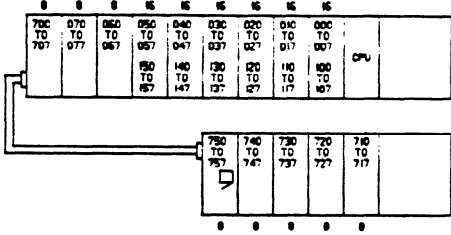
Series One™ Junior Programmable Controller

The Series One Junior programmable controllers are a group of low cost controllers specifically designed for control applications requiring 4 to 60 relays. The Series One Junior offers a control package using only 53 square inches of mounting area, which is about the same as four 4-pole relays. Series One Junior PCs are available in various combinations of voltages.

Each Series One Junior basic unit has 24 built-in I/O circuits, including 15 inputs and 9 outputs. User memory is 700 words of CMOS-RAM, or optional EPROM memory. If more than 24 I/O points are required, expansion is accomplished by one of two methods, either add a Series One Junior I/O expansion unit or a 5 or 10 slot expansion rack to the basic unit. A system can have up to 50 I/O points by adding an I/O expansion unit, which has the same form as the basic unit. Up to 96 I/O points can be included in a system by adding a standard Series One 5 or 10-slot rack to the Series One Junior basic unit.

Any combination of standard Series One I/O modules can be included in an expansion rack, with the exception of the High Speed Counter module or the Thumbwheel Interface Unit. The expansion rack can be located up to 100 feet (30 m) from a Series One Junior.

The Series One Junior has a built-in high speed counter capable of counting pulses up to 2000 counts per second. The programming language is the same (basic ladder diagram functions) as is used to program the Series One and Series One Plus. Programs can be entered using either the hand-held programmer, which can be mounted on the basic unit, or the LCD Portable Programmer. Many programs developed on the Series One Junior PC can be transferred to a Series One or Series One Plus PC.

Table D-1. Series One Junior Capabilities

Number of I/O Points (Maximum)	96 total
Basic Unit Inputs	15
Basic Unit Outputs	9
Expansion Unit Inputs	16
Expansion Unit Outputs	10
Expansion Rack I/O (Mixed I/O)	72
Internal Coils	160 total
Non-Retentive	96
Retentive	59
Special Function	5
Shift Registers	128 steps
Timers/Counters	64 (1)
High Speed Counter, Built-In	1
Sequencers	64 (1000 steps)

(1) Maximum total number of Timers and Counters or a combination of Timers and Counters. Optional devices include the Timer/Counter Setpoint Unit, Data Communications Unit, Printer Interface Unit, PROM Writer Unit, and an audio cassette tape recorder.

Series Three™ Programmable Controller

The Series Three PC is a compact programmable controller capable of handling applications in the 16 to 400 I/O range. It offers many of the same outstanding features as the Series One family of programmable controllers such as compact size, CMOS or PROM memory, hand held programmer, and low price. Improved capabilities include 4K memory, 400 I/O points, and four function math. Following are specifications for the Series Three PC:

Table D-2. Series Three PC Specifications

Size for CPU and 128 I/O (W x H x D)	18.9" x 10.3" x 6.3 (480mm x 262mm x 159mm)
Functions	Relay including Latches Timers (1.0, 0.1 Sec) Counters Master Control Relay Shift Registers Add, Subtract, Compare Multiply, Divide Data Moves Subroutine
Scan Rate	20 msec. for 2K 40 msec. for 4K
Internal References	400 I/O 64 Latches 304 Internal Coils 128 Shift Register Stages 128 Timer/Counters (4 digit)
Programmer	Built-In with Keylock

Available I/O Types

INPUTS	I/O POINTS	OUTPUTS	I/O POINTS
115 V ac/dc	16	115/230 V ac (2 A)	16
Isolated 115 V ac	8	Isolated 115/230 V ac (2A)	8
24 V dc	16	24 V dc (2 amp)	8
24 V dc	32	24 V dc (1 Amp)	16
24 V ac/dc Source	16	24 V dc	32
230 V ac	16	Relay Out	16
Analog	2	Analog	2
5 - 12 V dc	32	5 - 12 V dc	32

OTHER MODULES

High Speed Counter, I/O Link Local and Remote (Twisted Pair and Fiber Optics), Data Communications, 24 V dc In/Out (16/16), I/O Simulator

GEK-90842

Series Six™ Programmable Controller

The family of Series Six programmable controllers consists of three models: 60, 600, 6000. The capacity for memory and Input/Output increases as the model number increases. Each model also has internal register storage in varying sizes. The family concept allows the use of common features between models. The common features include a common programming language featuring a basic, extended, and advanced set, the same reference numbers, the same Workmaster industrial computer for programming and running many available programs tailored for industrial applications, the same I/O structure; including modules, racks and cables, most of the same CPU modules, transportable programs from one model or size to another (upward or downward compatibility) and the same options. Memory and I/O capability are listed in Table D.3.

Table D-3. Series Six CPU Capacities

MODEL	LOGIC MEMORY	I/O CAPACITY		REGISTER STORAGE
		INPUTS	OUTPUTS	
60	4K	1000	1000	1024
600	8K	1000	1000	8192
6000	32K	2000	2000	8192

Programming

Programs are entered using the LogicMaster 6 software package on the Workmaster® industrial computer. The Workmaster has a 9" CRT display, a full-travel keyboard, integral 3 1/2" diskette drive, and full off-line/stand along programming. Programming logic is basically a relay ladder diagram language consisting of relay ladder logic (N.O. and N.C. contacts, counters, timers, one-shots and latches). Additional features in the Basic group include Arithmetic (add, subtract, and compare), data moves, binary and BCD conversion, a Master Control Relay function and communication requests. The extended Mnemonic group includes the following functions:

- Data Moves (Left 8, Right 8, Block)
- Signed Arithmetic (Double Precision Add and Subtract, Extended Add and Subtract, Multiply, Divide and Greater Than)
- Table Moves (Table-To-Destination, Source-To-Table, Move Table and Move Table Extended)
- List (Add-To-Top, Remove-From-Bottom, Remove-From-Top and Sort)
- Matrix (AND, OR, Exclusive OR, Invert and Compare)
- Bit Matrix (Bit Set, Bit Clear, Shift Right, Shift Left)
- Control (Do Subroutine, Return, Suspend I/O, Do I/O and Status)

The advanced function adds an additional Table Move instruction, Move Table Ex, which has the ability to address all 8192 registers in an advanced model 600 or a model 6000.

I/O modules available for the Series Six PCs include the following:

- 115/230 V ac/dc, Inputs and Outputs
- 115/230 V ac Isolated Inputs and Outputs
- 12 V ac/dc Inputs
- 24-48 V ac/dc Inputs
- 12, 24, 48 V dc Sink and Source Outputs
- 120 V dc Outputs
- High Density Inputs (32 Inputs)
- High Density Outputs (32 Outputs)

- Reed Relay Outputs
- Analog Inputs and Outputs
- Thermocouple Inputs
- Interrupt Inputs
- Axis Positioning, Type 1 and Type 2
- High Speed Counter
- ASCII BASIC module, 12K or 20K versions
- I/O Receiver and Transmitter for operation up to 2000 feet (600 meters).
- Remote I/O Driver and Receiver for cable operation up to 10,000 feet (3 Km) or unlimited distance over a modem link.

Optional Items

Optional items for use with a Series Six PC include a Redundant Processor Unit (RPU), Communications Control Modules, an Operator Interface Unit (OIU), color and amber Operator Interface Terminals (OIT), ProLoop™ process controllers, and various software packages for use with the Workmaster information center. The software packages include VuMaster™, FactoryMaster™, and ProcessMaster™. Additional software packages will be available in the future.

The RPU acts as a switch to transfer control from one Series Six CPU or I/O chain to a standby in the event that a failure occurs in the first. This provides a method of minimizing downtime in the event of a failure in the PC system.

The Type 2 Communications Control Module (CCM) provides 2 independent ports (RS-232C, RS-422, or 20 mA) for slave communications with computers or similar intelligent devices. The Type 2 CCM also has the added function of originating communications to other Series Six CPUs, computers, or other similar intelligent devices from the user's ladder diagram program. The Type 3 CCM also provides 2 ports, and the protocol required for interfacing to selected process control systems.

The OIU is a hand-held micro-terminal that allows an operator to monitor or modify the register contents and I/O states of a Series Six CPU. The OIU communicates with a CPU through the Communications Control module (Type 2).

The OIT connects to the Series Six through an ASCII/BASIC module and provides CRT background screens for the display of status from the CPU. User configuration of the screens allows tailoring the screens to fit the application.

The ProLoop process controllers are a group of analog controllers that can operate independent of, but be supervised by a Series Six PC.

Series Six™ Plus Programmable Controller

The Series Six Plus is a cost effective programmable controller that can be easily expanded to cover a wide variety of applications. The Series Six Plus offers in one rack, more capability than the Series Six family of programmable controllers, which includes models 60, 600 and 6000.

A Combined Memory module, which includes internal memory, up to 16K words of user memory and up to 16K of register memory, is available in six different configurations as shown below in Table D.4

Table D-4. Series Six Plus Combined Memory Configurations

Total Memory	User Memory	Register Memory
5K	4K	1K
12K	4K	8K
16K	8K	8K

GEK-90842

Table D-4. Series Six Plus Combined Memory Configurations - Continued

Total Memory	User Memory	Register Memory
24K	16K	8K
48K	32K	16K
80K	64K	16K

The Series Six Plus PC can be configured to have up to 16K Inputs and 16K Outputs. Instruction sets for programming are available in 3 versions; Advanced, Expanded, and Expanded II. The expanded function set has all previous Series Six instructions plus several new instructions and enhancements which include:

- Reference range expanded for 16K I/O
- Floating Point functions, including:
 - Add, subtract, multiply, divide, greater than
 - Integer to floating point
 - Floating point to integer
- Enhanced DO I/O and STATUS instructions
- New WINDOW function

The Series Six Plus PC also includes enhanced GENIUS I/O diagnostics and expanded error checking. The CPU rack, which contains all required CPU modules, has 6 slots available for I/O modules.

The Series Six Plus PC is compatible with all existing Series Six I/O modules, peripherals and software packages. Programs are entered with the Workmaster® industrial computer, as with the Series Six family of PCs.

GEK-90842

- 1**
- 10-Slot Rack, 2-3
 - 115 V ac Input Module, IC610MDL129, 6-76
 - 115 V ac Input Module, UL Listed
IC610MDL135, 6-73
 - 115 V ac Input, IC610MDL125, 6-7
 - 115 V ac Isolated Input, IC610MDL126, 6-9
 - 115 V ac Output Module, UL Listed
IC610MDL185, 6-75
 - 115/230 V ac Isolated Output
IC610MDL176, 6-17
 - 115/230 V ac Output IC610MDL175, 6-16
 - 16 Circuit I/O Modules with Connectors, 6-4
- 2**
- 230 V ac Input, IC610MDL127, 6-8
 - 24 V ac Sink Output (16 Circuits)
IC610MDL156, 6-19
 - 24 V ac Sink Output (8 Circuits)
IC610MDL151, 6-18
 - 24 V ac/dc Source Input (16 Circuits),
IC610MDL112, 6-14
 - 24 V ac/dc Source Input, IC610MDL111, 6-13
 - 24 V dc 2 Amp Sink Output
IC610MDL153, 6-22
 - 24 V dc 2 Amp Sink/Source Output
IC610MDL154, 6-23
 - 24 V dc Input/Output (4 In/4 Out)
IC610MDL103, 6-31
 - 24 V dc Input/Output (4 In/4 Out)
IC610MDL104, 6-33
 - 24 V dc Sink Input (16 Circuits),
IC610MDL106, 6-11
 - 24 V dc Sink Input (8 Circuits),
IC610MDL101, 6-10
 - 24 V dc Sink Load Input (16 Circuits),
IC610MDL107, 6-12
 - 24 V dc Sink Output (16 Circuits)
IC610MDL157, 6-20
 - 24 V dc Source Output (16 Circuits)
IC610MDL158, 6-26
 - 24 V dc Source Output IC610MDL155, 6-24
- 5**
- 5-Slot Rack, 2-3
 - 5-Slot Rack, UL Listed IC610CHS111, 6-72
- A**
- Accessory Kit, IC610ACC120, 7-6
 - Adding Memory, 7-5
 - Adding Racks, 2-2
 - Advantages and Features, 1-2
 - Advantages Over Other Control Devices, 1-1
 - Alter One Logic Element, 4-11
 - Analog Input IC610MDL116, 6-62
 - Analog Output IC610MDL166, 6-67
 - Appendix A - Related Documentation, A-1
 - Appendix B - Glossary of Terms, B-1
 - Appendix C - Compatibility Guide, C-1
 - Appendix D - Other Programmable
Controllers, D-1
 - Applications, 8-1
 - Application 1 - One-Shots, 8-1
 - Application 2 - Flip Flop, 8-2
 - Application 3 - Event/Time Drum, 8-3
 - Application 4 - Cascaded Counters, 8-5
 - Application 5 - Coil 374, Power-Up
One-Shot, 8-7
 - Application 6 - Coil 375, 10Hz Clock, 8-8
 - Application 7 - Start/Stop Circuit, 8-11
 - Application 8 - High Speed Counter, 8-12
 - Application 9 - Typical Shift Registers, 8-21
- B**
- Basic Instructions, 5-19
 - Basic Ladder Diagram Instructions, 5-1
 - Basic PC Block Diagram, 1-5
 - Basic Troubleshooting, 7-1
 - Bridge Connectors, 10-Slot Rack, 3-5
- C**
- Catalog Numbers, 5

Central Processing Unit, Function of, 1-6
 Change Contents of a Data Register, 4-14
 Clear All Memory, 4-12
 Components, Replacement of, 7-3
 CPU Option Settings, 3-8
 CPU Programmer Cable, 2-4
 CPU Scanning Sequence, 5-15

D

Data Communications, 1-3
 Data Communications Unit, 1-8, 2-10
 Data Operation Block Diagram, 5-43
 Data Operation Instructions, 5-4, 5-43
 Data Registers, 5-13
 DCU, 2-10
 Delete One Logic Element, 4-12
 Display a Specific Address, 4-13

E

Earth Ground Wire, 3-10
 Enter or Change a Password, 4-14
 LOG IN, 4-14
 LOG OUT, 4-15
 Entering Basic Instructions, 5-24
 AND STR, OR STR, 5-24
 Basic Relay Logic, 5-20
 Disabling of Outputs, 5-29
 Latched Relay, 5-26
 Master Control Relay, 5-27
 Normally Closed Input, 5-22
 Push-Down Stack, 5-23
 Retentive Coils as Latches, 5-26
 Rung with Parallel Contacts, 5-20
 Rung with Series Contacts, 5-19
 Simple Timer Rung, 5-20
 Error Code Definitions, 4-7
 Error Codes, 4-7
 Example of Counters, 5-33
 Example of Relay Control, 2-9
 Example of Timer Logic, 5-31
 Expanded Cable Installation, 2-4

F

Fast Response I/O IC610MDL115, 6-56
 Faster Scan Rate, 1-3
 Field Wiring to I/O Modules, 6-2
 Forcing I/O References, 5-42
 Forcing References, 4-15
 Fuse List, 7-7

G

General Specifications, 1-3
 General Troubleshooting, 7-2
 Ground, Earth, 3-10
 Grounding, Rack, 3-3

H

Hand-Held Programmer, 1-1, 1-5
 Hardware Requirements, 2-7
 Heat Dissipation, 2-2
 High Density Module with Removable
 Connector, 6-3
 High Speed Counter IC610MDL110, 6-39
 History of Programmable Controllers, 1-1

I

I/O Addressing Switches, 3-6
 I/O Expansion Cable Connection, 3-4
 I/O Interface Cable Cross Reference List, 6-5
 I/O Interface Cable Wiring List, 6-4
 I/O Module Capability/Compatibility
 Guide, C-3
 I/O Module Catalog Numbers, 6-6
 I/O References for 16 Circuit Modules, 6-4
 I/O Simulator IC610MDL124, 6-61
 I/O Specifications and Wiring, 6-1
 IC610CHS111, 5-Slot Rack, UL Listed, 6-72
 IC610MDL101, 24 V dc Sink Input (8
 Circuits), 6-10
 IC610MDL103, 24 V dc Input/Output (4 In/4
 Out), 6-31

GEK-90842

- IC610MDL104, 24 V dc Input/Output (4 In/4/Out), 6-33
 - IC610MDL105, Thumbwheel Interface, 6-36
 - IC610MDL106, 24 V dc Sink Input (16 Circuits), 6-11
 - IC610MDL107, 24 V dc Sink Load Input (16 Circuits), 6-12
 - IC610MDL110, High Speed Counter, 6-39
 - IC610MDL111, 24 V ac/dc Source Input, 6-13
 - IC610MDL112, 24 V ac/dc Source Input, 6-14
 - IC610MDL115, Fast Response I/O, 6-56
 - IC610MDL116, Analog Input, 6-62
 - IC610MDL124, I/O Simulator, 6-61
 - IC610MDL125, 115 V ac Input, 6-7
 - IC610MDL126, 115 V ac Isolated Input, 6-9
 - IC610MDL127, 230 V ac Input, 6-8
 - IC610MDL129, 115 V ac Input Module, 6-76
 - IC610MDL135, 115 V ac Input Module, UL Listed, 6-73
 - IC610MDL151, 24 V ac Sink Output (8 Circuits), 6-18
 - IC610MDL153, 24 V dc 2 Amp Sink Output, 6-22
 - IC610MDL154, 24 V dc 2 Amp Sink/Source Output, 6-23
 - IC610MDL155, 24 V dc Source Output, 6-24
 - IC610MDL156, 24 V ac Sink Output (16 Circuits), 6-19
 - IC610MDL157, 24 V dc Sink Output (16 Circuits), 6-20
 - IC610MDL158, 24 V dc Source Output (16 Circuits), 6-26
 - IC610MDL16, Analog Output, 6-67
 - IC610MDL175, 115/230 V ac Output, 6-16
 - IC610MDL176, 115/230 V ac Isolated Output, 6-17
 - IC610MDL180, Relay Output (8 Circuits), 6-27
 - IC610MDL181, Relay Output Module, UL Listed, 6-74
 - IC610MDL182, Relay Output (16 Circuits), 6-29
 - IC610MDL185, 115 V ac Output Module, UL Listed, 6-75
 - Input/Output Circuitry, 1-7
 - Insert One Logic Element, 4-12
 - Installation, 3-2
 - CPU, 3-7
 - I/O, 3-9
 - I/O Field Wiring, 3-10
 - Power Connections, 3-10
 - Programmer, 3-11
 - Racks, 3-2
 - Installation of Programmer Cable, 3-13
 - Installation, Specifications, 3-1
 - Instruction Groups, 5-7
 - Internal Coils, 5-13
 - Introduction to Maintenance Procedures, 7-1
 - Introduction to Programming, 5-1
- ## L
- Ladder Diagram Format, 5-17
 - List of Fuses, 7-7
 - Location of Extra Memory Socket, 7-5
 - Logicmaster 1 Application Software, 1-1
 - Logicmaster 1 Family Application Software, 1-6
 - Logicmaster 1F Application Software, 1-1
- ## M
- Memory Size, 3-8
 - Monitor Counter Status, 4-13
 - Monitor CPU Logic, 4-10
 - Monitor Data Register Contents, 4-14
 - Monitor I/O Status, 4-12
 - Monitor Timer Status, 4-13
- ## O
- Operating Principles, 5-14
 - Scanning, 5-14
 - Operation Sequences, 4-8
 - Operation With Peripheral Devices, 4-15
 - Loading a Program, 4-18
 - Recording a Program, 4-16
 - Tape Recorder, 4-15
 - Verifying a Program, 4-16
 - Optional Hardware, 2-8

P

Password Protection, 1-3
 PC Operation, 4-1
 PC Terminology, 1-8
 Peripheral Devices, 2-9
 Peripheral Devices, Operation, 4-15
 Planning a PC System, 5-1
 Portable Programmer, 1-1, 1-5
 Power Flow, 5-17
 Power Supply Limitations, 3-13
 Printer Interface Unit, 2-11, 4-18
 Printer Requirements, 4-19

- 80/132 Column Selection Switch, 4-21
- External Power Supply Connector, 4-21
- Hardware Description, 4-19
- Hardware Features, 4-20
- Power Supply Select Switch, 4-21
- Sequence of Operation, 4-22

 Program Checking, 4-7
 Programmable Controller Concepts, 1-5
 Programmer, 4-1
 Programmer Cable, 3-11
 Programmer Features, 4-2

- Address Data Display, 4-2
- Data Operation Keys, 4-6
- Editing Keys, 4-4
- Logic Display, 4-2
- Logic Keys, 4-3
- Mode Switch, 4-2
- Peripheral Jack, 4-7
- Shifted Functions, 4-5
- Status Display, 4-2

 Programmer Functions, 5-15
 Programmer Mount Assembly, 2-4
 Programmer Tape Port, 2-4
 Programming, 1-5
 Programming Function Compatibility Guide, C-5
 Programming Fundamentals, 5-7
 Programming the Data Operation Instructions, 5-45

- Addition (+), BCD 4 Digit (F71), 5-53
- BCD (Binary to BCD) (F86), 5-70
- BIN (BCD to Binary) (F85), 5-69
- CMPR (F70), 5-52

(Programming the Data Operation Instructions cont)

- D•AND (DATA AND) (F75), 5-61
- D•OR (DATA OR) (F76), 5-63
- D•OUT (F60), 5-50
- D•OUT1 (F61), 5-50
- D•OUT2 (F62), 5-51
- D•OUT3 (F63), 5-51
- D•OUT5 (F65), 5-52
- D•STR (F50), 5-47
- D•STR1 (F51), 5-48
- D•STR2 (F52), 5-48
- D•STR3 (F53), 5-49
- D•STR5 (F55), 5-49
- Decode (F82), 5-67
- Division (:), BCD 4 Digit (F74), 5-59
- Encode (F83), 5-68
- External Fault Diagnosis (F20), 5-71
- INV (F84), 5-68
- Multiplication (X), BCD 4 Digit (F73), 5-58
- Shift Left (F81), 5-65
- Shift Right (F80), 5-65
- Special Function Coils, 5-46
- Subtraction (-), BCD 4 Digit (F72), 5-56

Programming, Introduction to, 5-1
 PROM Writer Unit, 2-12, 4-29

- Front Panel Features, 4-30
- Power Supply Select Switch, 4-31
- Sequence of Operation, 4-31

 Proper Heat Dissipation, 3-2

R

Rack Description, 2-1
 Rack Grounding, 3-3
 Rack Mounting Dimensions, 3-2
 Recommended Field Wiring Procedures, 3-15
 Referencing Sequencer Contacts, 5-37
 Relay Output (16 Circuits)

- IC610MDL182, 6-29

 Relay Output (8 Circuits) IC610MDL180, 6-27
 Relay Output Module, UL Listed

- IC610MDL181, 6-74

 Remote I/O, 1-8
 Removable Connector, 6-3

GEK-90842

Replacement of Components, 7-3
 Replacing a CPU, 7-3
 Replacing a Rack, 7-3
 Replacing I/O Modules, 7-4
 Replacing the Battery, 7-4
Requirements, Hardware, 2-7
Routing of I/O Wiring, Typical, 3-11

S

Safety Considerations, 3-15
Search CPU Logic, 4-11
Sequencer Operation, 5-36
Series One Execution Times, 5-3
Series One Model E, 1-3
Series One Plus 3.7K, 1-3
Series One Plus Program Protection, 1-6
Series One Programmable Controllers, 1-1
Shift Register, 5-38
 Operation, 5-40
 References, 5-39
Shift Register References, 5-13
Significance of References, 5-7
Spare Parts and Components, 7-6
Special Function Coils, Use of, 5-13
Specifications for Installation, 3-1
Summary of I/O References for 8 Circuit Modules, 5-10
Summary of Programming References, C-4
Summary of References, 5-8
System Estimating, 2-7

T

Thumbwheel Interface IC610MDL105, 6-36
Timer and Counter, 5-30
 Extending Timer/Counter Range, 5-34
 Programming Counters, 5-32
 Programming Timers, 5-30
 Timer/Counter References, 5-30
Timer and Counter References, 5-13
Timer/Counter Setpoint Unit, 4-32
 Example of Using Thumbwheel Inputs, 4-34
 References for, 4-33
 Remote Mounting, 4-33

(Timer/Counter Setpoint Unit cont)
 Specifications, 4-33
Total Scan Time, 5-14
Troubleshooting Aids, 7-1
Types of Memory, 1-7
 CMOS RAM, 1-7
 PROM, 1-7
Typical I/O Terminal Configuration, 6-3
Typical Rack, 2-1
Typical Sequencer Logic, 5-37

U

UL Listed Products, 1-7, 6-71
Units of Load, 3-13
Units of Load Supplied by Rack, 3-13
Units of Load Used by Modules, 3-14, 3-15
Unlimited use of References, 5-18
Use of the Special Function Coils, 5-13
Using References for Data Operations, 5-44
 Data Register References, 5-44
 Entering a Constant Value, 5-44
 Entering a Group Reference, 5-44
 Timer/Counter References, 5-45

V

Valid System Configurations for I/O Points, C-6

W

Workmaster Industrial Computer, 1-1

GE Fanuc Automation North America, Inc., Charlottesville, Virginia