

D4-RM, D4-RS & D4-RSDC
Remote Master/Remote Slave
Manual Number D4-REMIO-M

Shaded area represents the die-cut covers from
Imaging Technologies, 5-98



WARNING

Thank you for purchasing automation equipment from **PLCDirect™**. We want your new **DirectLOGIC™** automation equipment to operate safely. Anyone who installs or uses this equipment should read this publication (and any other relevant publications) before installing or operating the equipment.

To minimize the risk of potential safety problems, you should follow all applicable local and national codes that regulate the installation and operation of your equipment. These codes vary from area to area and usually change with time. It is your responsibility to determine which codes should be followed, and to verify that the equipment, installation, and operation is in compliance with the latest revision of these codes.

At a minimum, you should follow all applicable sections of the National Fire Code, National Electrical Code, and the codes of the National Electrical Manufacturer's Association (NEMA). There may be local regulatory or government offices that can also help determine which codes and standards are necessary for safe installation and operation.

Equipment damage or serious injury to personnel can result from the failure to follow all applicable codes and standards. We do not guarantee the products described in this publication are suitable for your particular application, nor do we assume any responsibility for your product design, installation, or operation.

If you have any questions concerning the installation or operation of this equipment, or if you need additional information, please call us at 1-800-633-0405.

This publication is based on information that was available at the time it was printed. At **PLCDirect™** we constantly strive to improve our products and services, so we reserve the right to make changes to the products and/or publications at any time without notice and without any obligation. This publication may also discuss features that may not be available in certain revisions of the product.



Trademarks

This publication may contain references to products produced and/or offered by other companies. The product and company names may be trademarked and are the sole property of their respective owners. **PLCDirect™** disclaims any proprietary interest in the marks and names of others.

Stage is a trademark of Koyo Electronics Industries Co., LTD. Think & Do Software is a trademark of Think & Do Software, Inc. Texas Instruments is a registered trademark of Texas Instruments, Inc. TI, TIWAY, Series 305, Series 405, TI305, and TI405 are trademarks of Texas Instruments, Inc. Siemens and SIMATIC are registered trademarks of Siemens, AG. GE is a registered trademark of General Electric Corporation. Series One is a registered trademark of GE Fanuc Automation North America, Inc. MODBUS is a registered trademark of Gould, Inc. IBM is a registered trademark of International Business Machines. MS-DOS and Microsoft are registered trademarks of Microsoft Corporation. Windows and Windows NT are trademarks of Microsoft Corporation. OPTOMUX and PAMUX are trademarks of OPTO 22.

**Copyright 1997, PLCDirect™ Incorporated
All Rights Reserved**

No part of this manual shall be copied, reproduced, or transmitted in any way without the prior, written consent of **PLCDirect™** Incorporated. **PLCDirect™** retains the exclusive rights to all information included in this document.

Manual Revisions

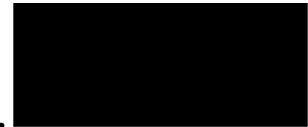

If you contact us in reference to this manual, be sure and include the revision number.

Title: DL405 Remote Master/Remote Slave D4-RM, D4-RS, and D4-RSDC, Rev C

Manual Number: D4-REMIO-M

Issue	Date	Effective Pages	Description of Changes
Original	11/94	Cover/Copyright Contents 1-1 - 1-13 2-1 - 2-9 3-1 - 3-9 4-1 - 4-11 A-1 - A-2 B-1 - B-4 C-1 - C-6	Original Issue
Rev. A	1/95		Adds FILL instruction in several RLL examples.
Rev. B	4/95		Corrects LDA instruction in several RLL examples.
Rev. C	6/98		Minor corrections

Table of Contents

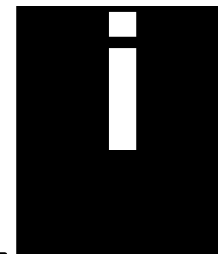

Chapter 1: Getting Started

Introduction	1-2
The Purpose of this Manual	1-2
Who Should Read this Manual	1-2
Where to Begin	1-2
Supplemental Manuals	1-2
How this Manual is Organized	1-3
Technical Assistance	1-3
What is Remote I/O?	1-4
When Do You Need Remote I/O?	1-4
Number of Masters and Slaves Allowed	1-5
How Does the DL405 Support Remote I/O?	1-5
Distance Between Slaves and Master, Baud Rates	1-6
Remote Master (D4-RM) Features	1-7
Specifications	1-7
Remote Slave (D4-RS or D4-RSDC) Features	1-8
Specifications	1-8
Assigning the Remote Input and Output Addresses	1-9
You Assign the Addresses	1-9
Remote I/O Data Types	1-9
Specify Addresses with Setup Logic	1-9
How the CPU Updates Remote I/O Points	1-10
3 Easy Steps for Setting Up Remote I/O	1-11
Step One: Design the System	1-11
Step Two: Install the Components	1-11
Step Three: Write the Setup Program	1-11
Example Setup Diagram	1-12

Chapter 2: Designing a Remote I/O System

Designing Your System	2-2
Determine I/O Needed and How Many Masters & Slaves	2-2
Define Your Idea By Using Worksheets	2-2
Filling Out the Remote Slave Worksheet for Slave #1	2-3
Filling Out the Remote Slave Worksheet for Slave #2	2-4
Filling Out the Remote Slave Worksheet for Slave #3	2-5
Calculating the Power Budget	2-6
Managing your Power Resource	2-6
CPU Power Specifications	2-6
Module Power Requirements	2-6
Power Budget Calculation Example	2-8
Which Modules Can Go In the Remote Bases	2-9



Chapter 3: Installation & Field Wiring Guidelines

Introduction	3-2
4 Easy Steps:	3-2
Step One: Setting the Front Rotary Switch	3-3
Step Two: Setting the Rear DIP Switches	3-4
Step Three: Inserting the Module in the Base	3-6
Step Four: Connecting the Wiring	3-7
General Wiring Guidelines	3-7
Power Connections for the D4-RS or D4-RSDC	3-7
Cabling Between the Master and Slaves	3-8
Termination Resistors	3-8
Connecting the Run Output Circuit	3-9

Chapter 4: Writing the Setup Program

Getting Started with Your Programming	4-2
Writing Your Remote I/O Setup	4-3
Step 1: Decide How You Are Going to Call Your Program	4-3
Step 2: Write the Setup Logic For Each Remote Base	4-4
Tell the CPU That You Are Finished With the Setup	4-5
A Completed Example	4-6
Special Relays Used for Remote I/O	4-8
How to Use the Special Relays	4-9
C670/C674: Setup Complete (Mandatory)	4-9
C700 to C707 and C720 to C727: Locate Communications Error (Optional)	4-9
C671/C675: I/O Status On Error (Optional)	4-9
C673/C677: Error/Restart But Ignore Problem Area (Optional)	4-10
C710 to C717 and C730 to C737: Communications OK Status (Optional)	4-10
Example of RLL Using All the Special Relays	4-11

Appendix A : Remote I/O Worksheet

Appendix B: Reserved Memory Tables

Remote Input/Output (GX) Addresses	B-2
Standard Input (X) Addresses	B-3
Standard Output (Y) Addresses	B-4
Control Relay (C) Addresses	B-5

Appendix C: Determining I/O Update Time

Overview	C-2
Remote I/O Update Table	C-3
Calculating Total Delay for the System	C-4
Total Delay Time Formulas	C-5
Delay Time Example	C-6

Getting Started

In This Chapter. . . .

- Introduction
 - What is Remote I/O
 - Remote Master (D4-RM) Features
 - Remote Slave (D4-RS or D4-RSDC) Features
 - Assigning the Remote Input and Output Addresses
 - How the CPU Updates Remote I/O Points
 - 3 Easy Steps for Setting Up Remote I/O
-

Manual Introduction

The Purpose of this Manual

This manual shows you how to install, program, and maintain the equipment. It also helps you understand the system operation characteristics.

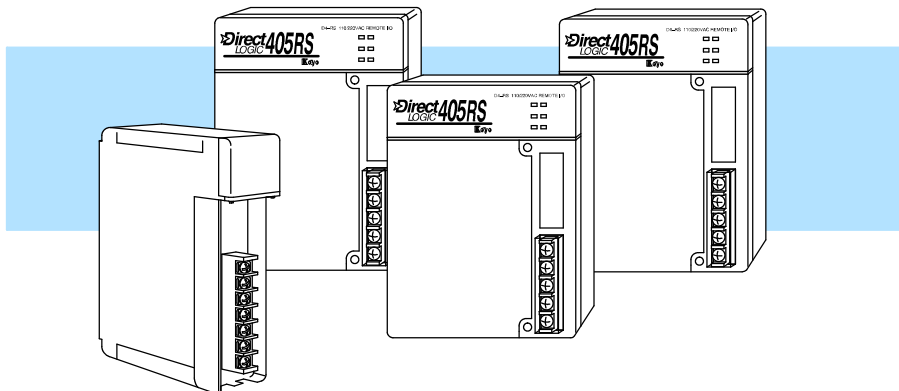

Who Should Read this Manual

If you understand PLC systems, our manuals will provide all the information you need to get and keep your remote I/O system up and running. We will use examples and explanations to clarify our meaning and perhaps help you brush up on specific features used in the DL405 system. This manual is not intended to be a generic PLC training manual, but rather a user reference manual for the DL405 remote I/O system.

Supplemental Manuals

Depending on the products you have purchased, there may be other manuals necessary for your application. You will want to supplement this manual with any other manuals written for other products. We suggest:

- D4-USER-M (the D4-405 User Manual)
- DA-DSOFT-M (the *DirectSOFT* User Manual)

Technical Support

We realize that even though we strive to be the best, the information may be arranged in such a way you cannot find what you are looking for. First, check these resources for help in locating the information:

- **Table of Contents** - chapter and section listing of contents, in the front of this manual
- **Quick Guide to Contents** - chapter summary listing on the next page
- **Appendix** - reference material for commonly used networking terms
- **Index** - alphabetical listing of key words, at the end of this manual

You can also check our online resources for the latest product support information:

- **Internet** - the address of our Web site is <http://www.plcdirect.com>
- **Bulletin Board Service(BBS)** - call (770)-844-4209

If you still need assistance, please call us at 800-633-0405. Our technical support group is glad to work with you in answering your questions. They are available Monday through Friday from 9:00 A.M. to 6:00 P.M. Eastern Standard Time. If you have a comment or question about any of our products, services, or manuals, please fill out and return the 'Suggestions' card that was shipped with this manual.

Key Topics for Each Chapter

The beginning of each chapter will list the key topics that can be found in that chapter.

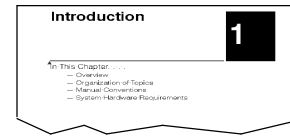
**Chapters**

Below is a table showing a summary of contents provided within each section of this manual. The manual is organized into the following four chapters:

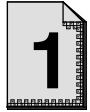
**Getting Started**

contains information you need to know to get started. It includes a brief description of a remote I/O system, the basic components of the system, and an overview of the steps necessary to develop a working system.

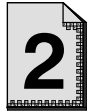
**Designing Your Remote I/O System**

shows you how to design your system. It includes a tutorial on how to use worksheets to keep track of all the remote I/O and the address assignments for remote I/O. It provides the framework for developing the necessary information you will need for programming and hardware setup.

**Installation and Communication Wiring Guidelines**

shows you how to install your modules. This chapter includes wiring information, shows you how to set the rotary dial and dip switch on each module, how to daisy chain the remote units, how to size and use termination resistors, and how to connect the Run Output circuit.

**Writing the Setup Program**

shows you how to use *DirectSOFT* to write the remote I/O setup program. This chapter takes the information developed from your worksheets and helps you develop a working program.

Appendices

Additional information is available in the following appendices.

**Remote I/O Worksheet**

included is a blank worksheet that can be copied and used for designing your system.

**Reserved Memory Tables**

shows the reserved memory locations for the transfer of remote I/O data. It is cross-referenced by data type.

**Determining I/O Update Time**

shows you how to calculate the amount of delay inherent with the transfer of data back and forth between the master and its remote slaves. Provides tables for both 19.2 kB and 38.4 kB, based on number of I/O points used.

What is Remote I/O?

A remote I/O system allows you to locate I/O modules in bases at some remote distance from the CPU base, but still under its control. These remote bases have no CPU of their own, and are completely controlled by the CPU in the main base via a special module called a **remote master**. Each remote base unit has a **remote slave** (consisting of an internal power supply and I/O adapter circuitry) that allows the exchange of data with the CPU in the main base via the master module. The communications link between the master and its slaves is provided by twisted-pair cable. Up to 512 remote I/O points can be supported by either the DL430 or DL440 CPU's, with baud rates of 19.2 and 38.4 kBaud.

One Master in CPU Base (1-Channel)

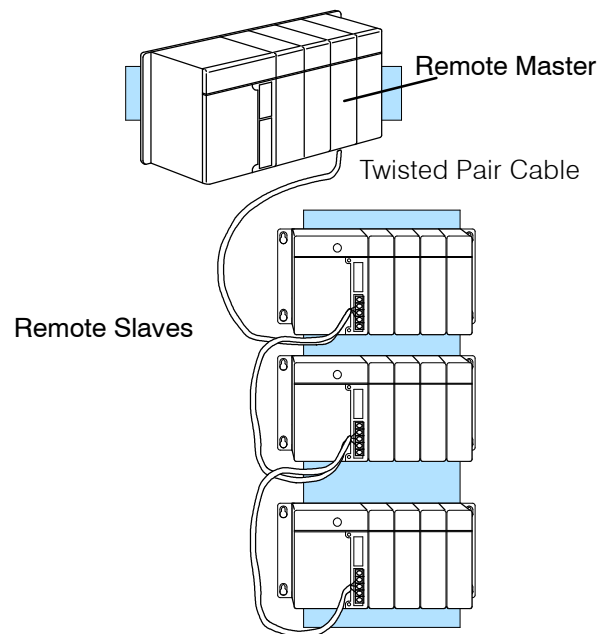

When Do You Need Remote I/O?

Remote I/O offers tremendous savings on wiring materials and labor costs for larger systems in which the field devices are in clusters at various spread-out locations. With the CPU in a main control room or some other central area, only the remote I/O cable is brought back to the CPU base. This avoids the use of a large number of field wires over greatly separated distances to all the various field devices. By locating the remote bases and their respective I/O modules close to the field devices, wiring costs are reduced significantly.

Another inherent advantage of remote I/O is the ability to add or remove slave bases, or temporarily take a base off line without disrupting the operation of the remaining system.

How Does the DL405 Support Remote I/O?

With the DL405 system, up to 512 remote I/O points can be supported by the DL440 CPU or the DL430 CPU.

The *remote master* is placed in the CPU base. This master (D4-RM) controls up to 7 *remote slaves* (D4-RS or D4-RSDC).

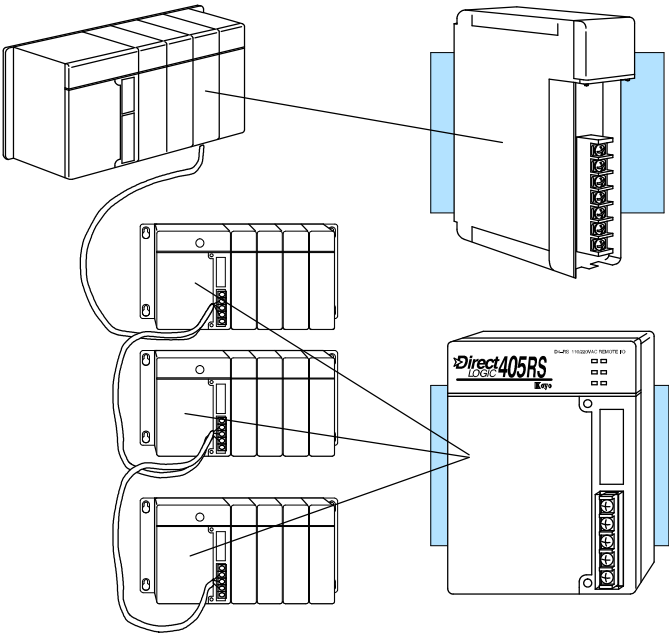

Remote Master -The D4-RM can link up to 7 remote slaves. It is mounted in the CPU base. Up to 2 masters can be used.

Remote Slave -The D4-RS and D4-RSDC are placed in remote base units. Each slave has a built-in power supply and the I/O circuitry required to be linked to the master module via twisted pair cable. Only one D4-RS or D4-RSDC is required for each remote base.

- D4-RS: Accepts AC power.
- D4-RSDC: Accepts DC power.

Number of Masters and Slaves Allowed

In its simplest form, you may want to use only one master in your CPU base and then attach from one to seven remote I/O bases. However, in addition to the simple configuration, more than one master can be placed in the CPU base. You may use a maximum of two masters per CPU base. Here is an example where we have placed two masters in the CPU base and then attached a total of six remote I/O racks.

Two Masters in the Same Base (2-Channel)

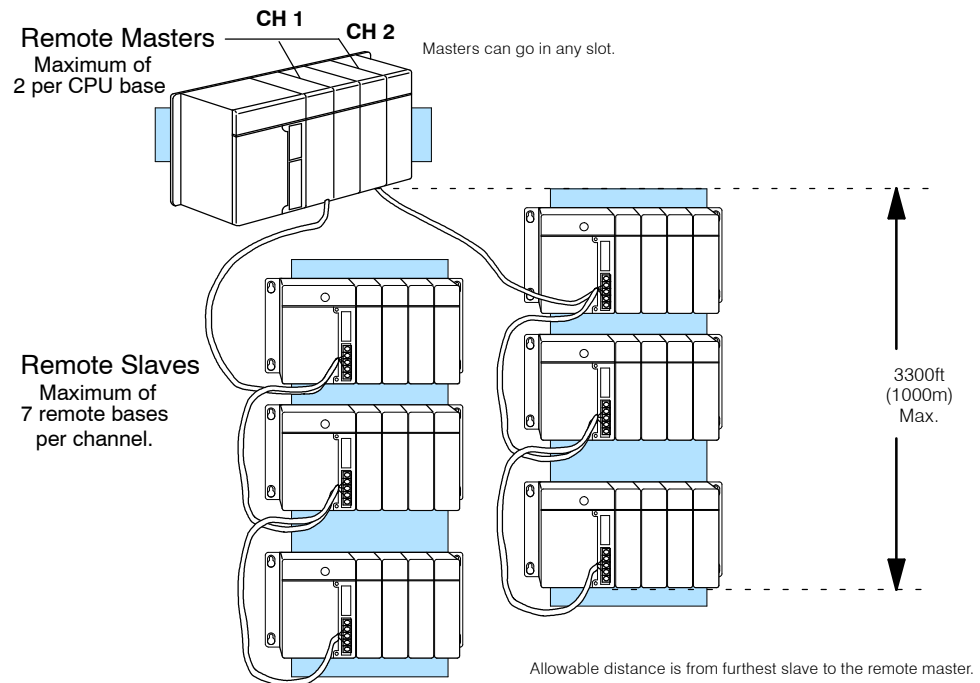

Distance Between Slaves and Master, Baud Rates

Each slave belonging to the same master is hooked together in a daisy chain using a shielded twisted pair cable. The last slave unit in the daisy chain cannot be further than 3300 feet from the CPU base. You set switches that designate the slaves as No. 1, No. 2, etc. There is an additional switch on each unit to set the baud rate for communication. You have your choice of either 19.2 kB or 38.4 kB. Slaves and Master must be set to the same baud rate.

Let's now take a closer look at each of the remote I/O modules.

Remote Master (D4-RM) Features

PWR--Turns ON at power up.

DIAG--Turns ON when there is a hardware failure.

I/O--Turns ON when ladder setup does not match the actual I/O, or the rotary switch is set to 0, 8 or 9, or a slave module controlled by the D4-RM causes an error.

MSTR--Turns ON to indicate that it is configured as a master.

RUN RELAY--Internal relay that is closed as long as there is a communications link present.

Remote Master

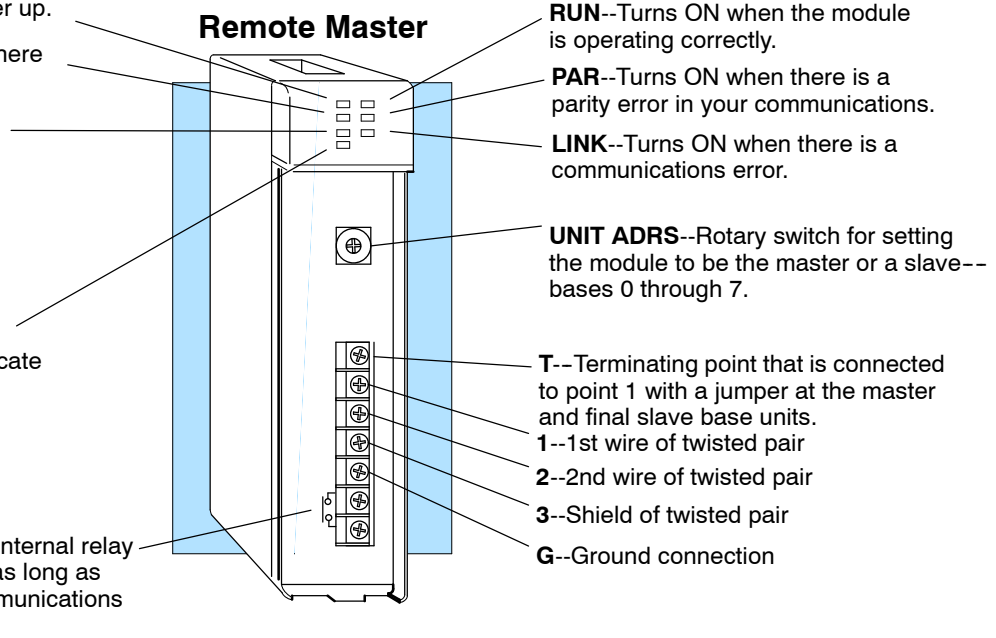

Specifications

Number of Masters per CPU	2 max. for DL430 or DL440
Maximum No. Slaves Supported	7
Number of Remote I/O Points per CPU	512
Module Type	Intelligent
Installation Requirements	Any slot, CPU base only
Internal Power Consumption	300 mA maximum
Digital I/O Consumed	None
Run Output Relay Rating	250 VAC at 1A 30 VDC at 1A
Communication Baud Rates	19.2 kB or 38.4 kB (Switch Selectable)
Communication Method	Asynchronous (half-duplex)
Communication Cabling	RS-485 twisted pair Belden 9271 or equivalent
Maximum Transimission Distance	3300 ft. (1000 meters)
Operating Temperature	32 to 140° F (0 to 60° C)
Storage Temperature	-4 to 158° F (-20 to 70° C)
Relative Humidity	5 to 95% (non-condensing)
Environmental air	No corrosive gases permitted
Vibration	MIL STD 810C 514.2
Shock	MIL STD 810C 516.2
Noise Immunity	NEMA ICS3-304

Remote Slave (D4-RS or D4-RSDC) Features

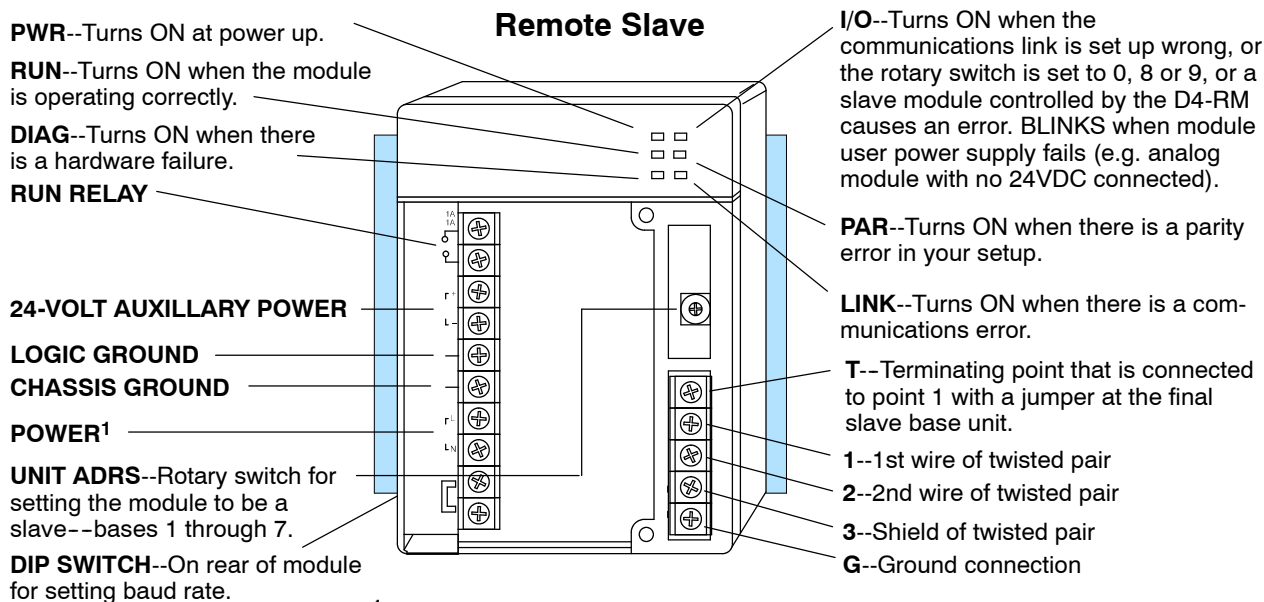

¹Depends on model-- D4-RS=AC, D4-RSDC=DC

Specifications

Slaves per channel	7
Module Type	Non-intelligent slave
Installation Requirements	CPU slot in any 4, 6 or 8-slot base
Power Required	110 VAC/220 VAC (D4-RS) 24 VDC (D4-RSDC)
Digital I/O Consumed	None Note: Consumes remote I/O points at a rate equal to the number of I/O points in each base.
Run Output Relay Rating	250 VAC at 1A 30 VDC at 1A
Communication Baud Rates	19.2 kB or 38.4 kB (Switch Selectable)
Communication Cabling	RS-485 twisted pair Belden 9271 or equivalent
Operating Temperature	32 to 140° F (0 to 60° C)
Storage Temperature	-4 to 158° F (-20 to 70° C)
Relative Humidity	5 to 95% (non-condensing)
Environmental air	No corrosive gases permitted
Vibration	MIL STD 810C 514.2
Shock	MIL STD 810C 516.2
Noise Immunity	NEMA ICS3-304

Assigning the Remote Input and Output Addresses

You Assign the Addresses

If you've used a DL405 CPU and local (or expansion) I/O before, then you probably know that the CPU will automatically assign the input and output addresses. That is, input points are automatically assigned starting at X0, and output points are automatically assigned starting at Y0. In a Remote I/O system, the input and output points in the remote bases are *not* automatically assigned in this manner. Instead, you have to add some setup logic to your control program that tells the CPU how to assign the addresses to the remote input and output points.

Remote I/O Data Types

In a local/expansion system, inputs are assigned starting at X0 and outputs are assigned starting at Y0. In a Remote I/O system, you can choose this conventional method, or you can choose to assign the inputs and outputs to other data types. For example, you could assign the remote inputs and outputs as GX (global) data type, or as the C (control relay) data type. This provides flexibility and becomes especially useful if you have already used all of the available X input and Y output addresses in your local and expansion bases.

For example, if you had a local/expansion system that used several 32-point input and output modules, you could easily use the entire limit of 320 X input or 320 Y output points (640 total max. I/O points). Now if you added modules in a Remote I/O system, there may not be any additional X input or Y output addresses available for the remote inputs and outputs. (In the vast majority of remote I/O systems, you *will* be able to use the X input and Y output addresses, but you can see that there may be occasions when you need a different data type for the remote points.

Specify Addresses with Setup Logic

The DL405 CPUs have specific memory locations (called pointers) that tell the CPU how to assign the remote I/O addresses. First, you use the tables (in Appendix B) to look up the next available starting address for the data type you want to use. Next, you use a combination of LDA, LD, and OUT store this information in the pointers.

Consider the following example. Although it hasn't been discussed yet, we know that V7404 is the pointer for the 1st Remote base belonging to the 1st Remote Master. If your starting address for the I/O points belonging to the 1st Remote are going to be X60, then you would look in Appendix B to find that the starting memory location for X60 is V40403. Then you would use LDA and OUT commands to map the address into that pointer (V7404). Next you would tell the CPU how many input points are in the Remote base. Then, you repeat the steps for the output points. Later in this manual you will be shown all the pointer addresses in a convenient table and we'll go into greater detail with additional examples.

Remote I/O Address Assignment

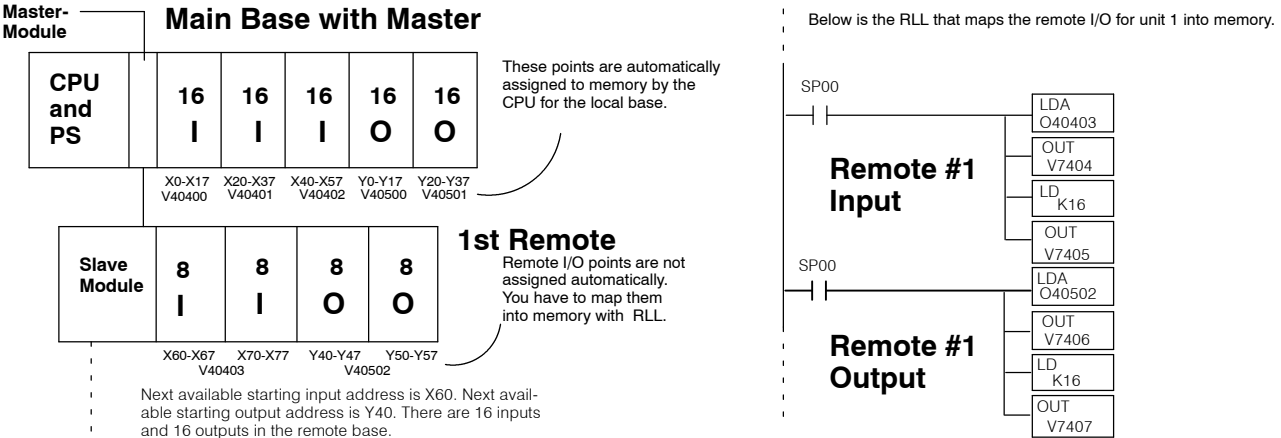

How the CPU Updates Remote I/O Points

The CPU and remote master work together to update the remote I/O points. Below is an example showing how scanning and updating takes place. Notice that there are two independent scan cycles going on at the same time, but asynchronously. The CPU module is doing its scan which includes looking at the information that the remote master is writing to its internal buffers.

During every CPU scan, the CPU examines the internal buffers of the remote master, and updates input and output data from the remote I/O. It is very possible for the CPU to be scanning faster than the remote master can do its scan. It is largely dependent on the size of the application program, the baud rate you have selected for the data transfer between the slaves and master, as well as the number of I/O points being monitored. Therefore, if you have I/O points that must be monitored on every CPU scan, you should place these critical I/O points in the local or expansion bases.

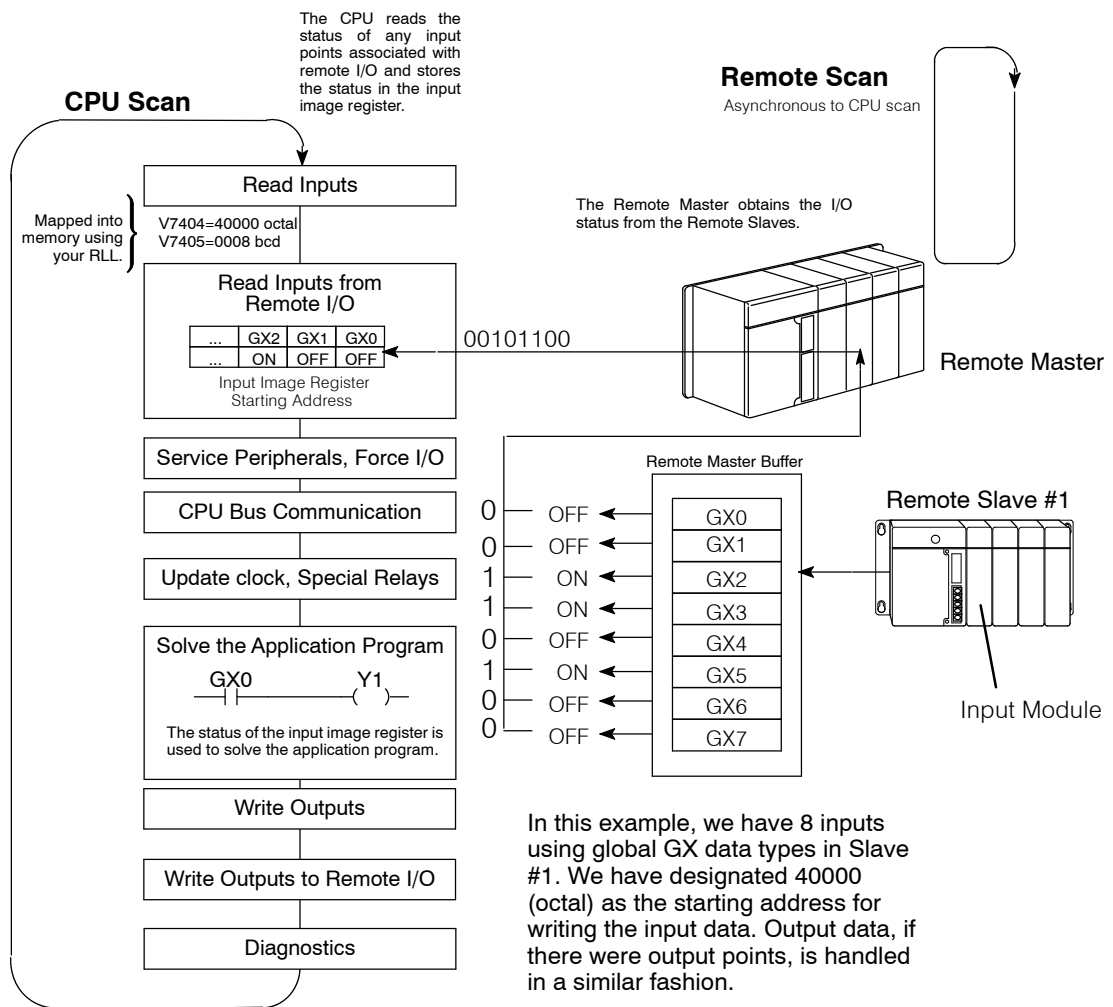

NOTE: In some cases it may be helpful to understand the update time required for a Remote I/O system. Appendix C shows example calculations.

3 Easy Steps for Setting Up Remote I/O

**Step One:
Design the System**

Figure out how much remote I/O you will need. This will, in turn, tell you how many remote masters and remote slaves you will need. **In Chapter 2**, we will show you how to use worksheets to plan and keep track of your data type assignments. We'll also show you how to determine the correct addresses for reading and writing remote I/O data.

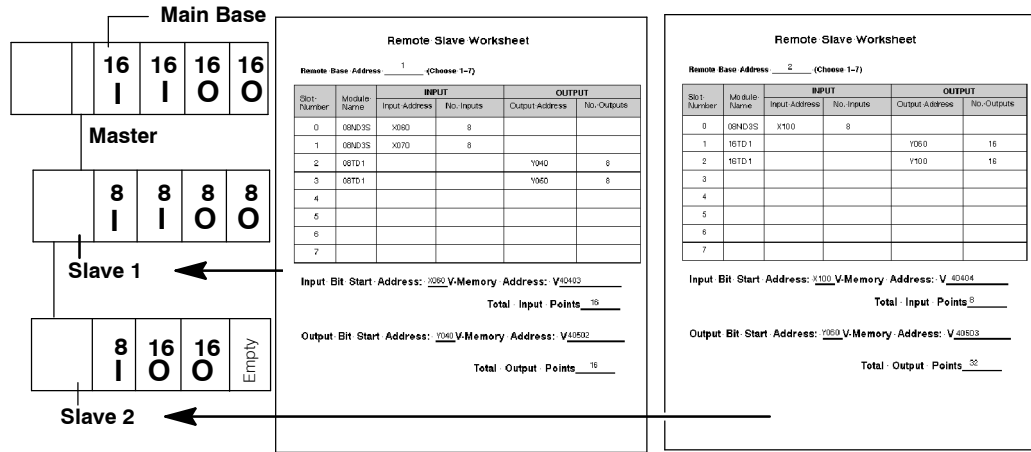

**Step Two:
Install the Components**

Install the bases and insert the master(s) and the remote slaves. Wire all of your I/O to match your information in Step 1. Set the hardware switches so that the CPU can identify the master and slave units. This also will set the baud rate for data transfer and designate how the slave units are numbered, i.e. No. 1, No. 2, and so on. **Covered in Chapter 3.**

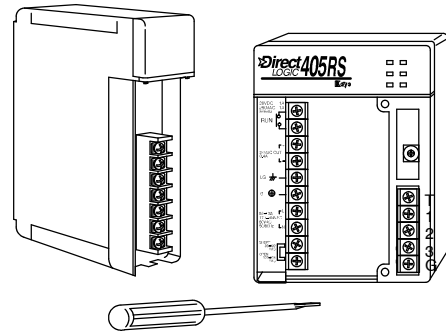

**Step Three:
Write the Setup Program**

Write the RLL setup program that will tell the CPU which address you want to use for the remote input and output points. **Covered in Chapter 4.**

The next two pages provide a complete overview of the entire process for an example remote I/O system. Of course, to learn all of the details, you should read each chapter carefully.

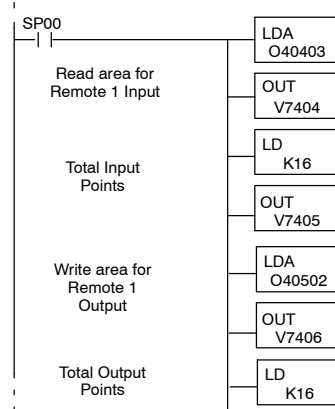

EXAMPLE:
38.4 kBaud, D4-440

Step 1: Design the Remote I/O System

Main Base with Master

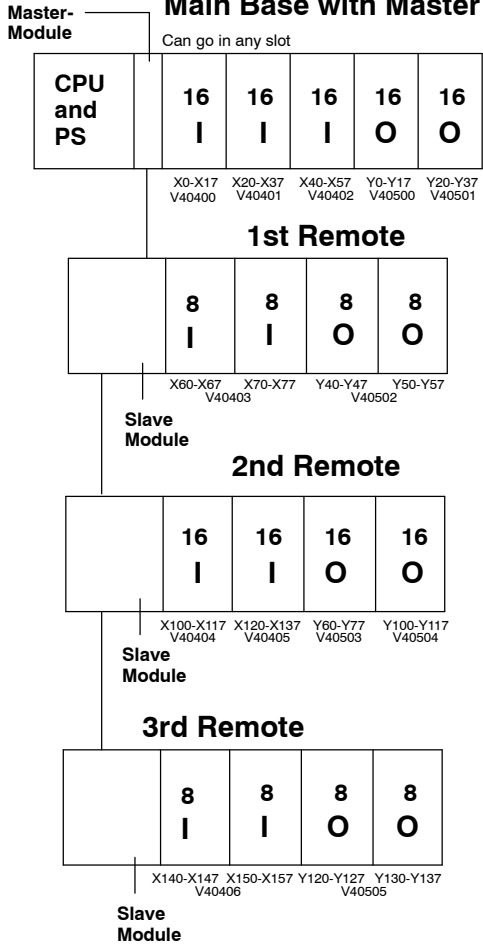

Remote Slave Worksheet

Remote Base Address 1 (Choose 1-7)

Slot Number	Module Name	INPUT		OUTPUT	
		Input Address	No. Inputs	Output Address	No. Outputs
0	08ND3S	X060	8		
1	08ND3S	X070	8		
2	08TD1			Y040	8
3	08TD1			Y050	8
4					
5					
6					
7					

Input Bit Start Address: X060 V-Memory Address:V 40403

Total Input Points 16

Output Bit Start Address: Y040 V-Memory Address:V 40502

Total Output Points 16

Remote Slave Worksheet

Remote Base Address 2 (Choose 1-7)

Slot Number	Module Name	INPUT		OUTPUT	
		Input Address	No. Inputs	Output Address	No. Outputs
0	16ND2	X100	16		
1	16ND2	X120	16		
2	16TD1			Y060	16
3	16TD1			Y100	16
4					
5					
6					
7					

Input Bit Start Address: X100 V-Memory Address:V 40404

Total Input Points 32

Output Bit Start Address: Y060 V-Memory Address:V 40503

Total Output Points 32

Remote Slave Worksheet

Remote Base Address 3 (Choose 1-7)

Slot Number	Module Name	INPUT		OUTPUT	
		Input Address	No. Inputs	Output Address	No. Outputs
0	08ND3S	X140	8		
1	08ND3S	X150	8		
2	08TD1			Y120	8
3	08TD1			Y130	8
4					
5					
6					
7					

Input Bit Start Address: X140 V-Memory Address:V 40406

Total Input Points 16

Output Bit Start Address: Y120 V-Memory Address:V 40505

Total Output Points 16

Note:

The Remote Slave Worksheet is found in Appendix A.

Step 2: Set the Hardware

Step 3: Write the Setup Program

Table for setting DIP switch

Position	1	2	3	4
Master	Always ON	ON=38.4kB OFF=19.2kB	Always OFF	Always OFF
Remote	Always OFF	ON=38.4kB OFF=19.2kB	Always OFF	Always OFF

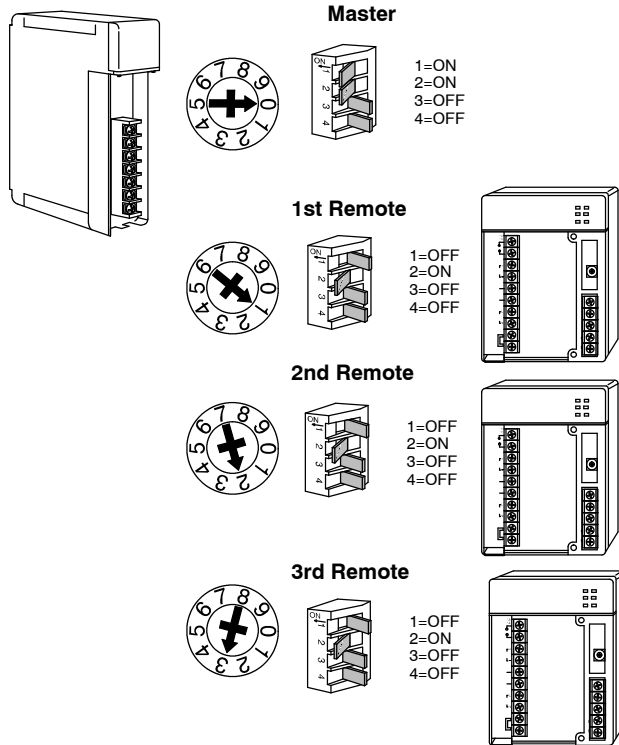
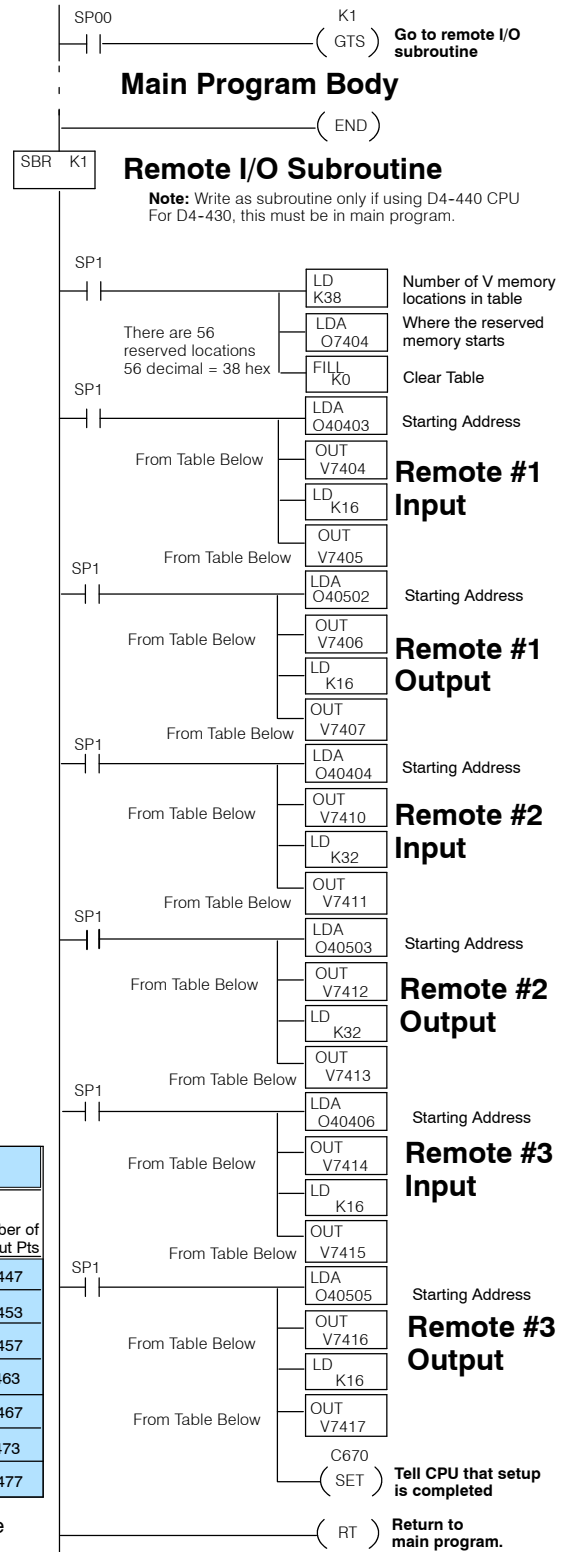

Table of Reserved Memory for Remote I/O Setup

First Master Module					Second Master Module			
Slave	Input Address	Number of Input Pts	Output Address	Number of Output Pts	Input Address	Number of Input Pts	Output Address	Number of Output Pts
1	V7404	V7405	V7406	V7407	V7444	V7445	V7446	V7447
2	V7410	V7411	V7412	V7413	V7450	V7451	V7452	V7453
3	V7414	V7415	V7416	V7417	V7454	V7455	V7456	V7457
4	V7420	V7421	V7422	V7423	V7460	V7461	V7462	V7463
5	V7424	V7425	V7426	V7427	V7464	V7465	V7466	V7467
6	V7430	V7431	V7432	V7433	V7470	V7471	V7472	V7473
7	V7434	V7435	V7436	V7437	V7474	V7475	V7476	V7477

= unused memory for this example

RLL Program



Designing a Remote I/O System

In This Chapter. . . .

- Designing Your System
 - Calculating the Power Budget
 - What Modules Can Go In the Remote Bases
-

Designing Your System

Determine I/O Needed and How Many Masters & Slaves

The first step in putting any system together is to at least establish a mental picture of the system components. You may even want to draw a diagram. Below is a drawing of a typical system with:

- one master module in the main base.
- main base has three input modules and two output modules, each with 16-points.
- first remote base has two input and two output modules--each with 8-points.
- second remote base has four 16-point modules--two input and two output.
- third remote base is identical to the first.

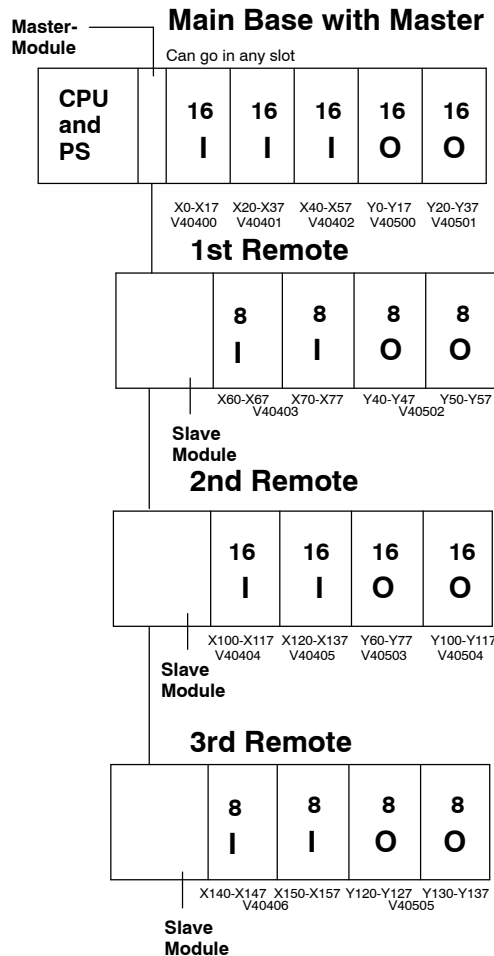

Better Define Your Idea By Using Worksheets

In Appendix A of this manual you will find a worksheet for planning the design of each of your remote I/O bases. We suggest that you photocopy this sheet and use it to map out the details of your system. Assuming this will be your procedure, this chapter will walk you through the process using the example visualized above. You will need the details from these worksheets when you set the switches on your hardware and you write the configuration code inside your ladder logic program.

Filling Out the Remote Slave Worksheet for Slave #1

The following remote slave worksheet has been filled in to match the first remote I/O base of the example system.

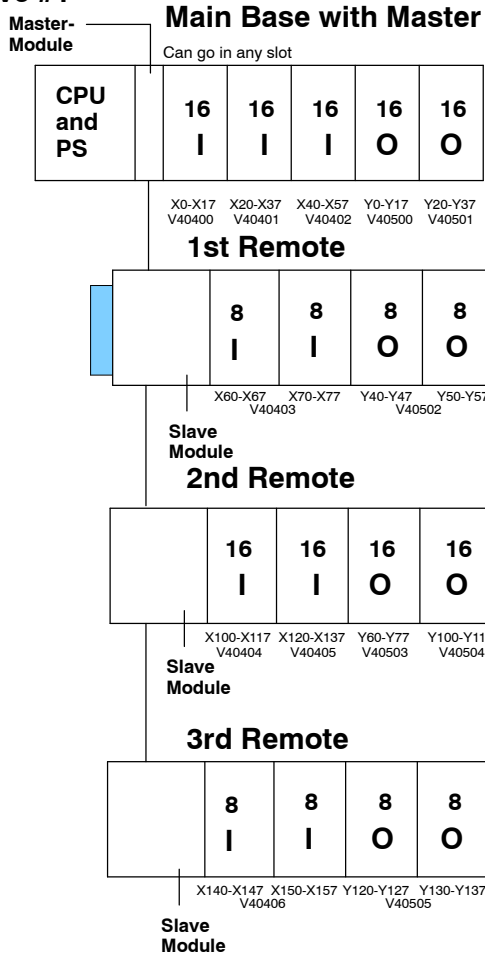

Remote Slave Worksheet

Remote Base Address 1 (Choose 1-7)

Slot Number	Module Name	INPUT		OUTPUT	
		Input Address	No. Inputs	Output Address	No. Outputs
0	08ND3S	X060	8		
1	08ND3S	X070	8		
2	08TD1			Y040	8
3	08TD1			Y050	8
4					
5					
6					
7					

Input Bit Start Address: X060 V-Memory Address: V 40403

Total Input Points Committed 16

Output Bit Start Address: Y040 V-Memory Address: V 40502

Total Output Points Committed 16

Starting Addresses From Appendix B = V40403 Input V40502 Output

In this example, the CPU base has 80 points allocated to its input and output modules, which are automatically configured as points X0 thru X57 and Y0 thru Y37. Thus, the starting address for the *first remote base* inputs can start at X060 (or higher) and the starting address for outputs can be Y040 (or higher). Turning to Appendix B, you look up the V-memory addresses for these points in their respective input and output memory address charts. The far right-hand column of each of these charts shows the “bit start” address. For example, for the bit start address for input X060 you look for 060 on the far left-hand portion of the chart. There you find the cross-referenced register address: 40403. On the output chart, you find cross-reference Y040 with 40502. These numbers are filled in at the bottom of the worksheet. They will be used later in your ladder logic.

Now let’s do the same thing for your *second* remote I/O base.

Filling Out the Remote Slave Worksheet for Slave #2

The following remote slave worksheet has been filled in to match the second remote I/O base of the example system.

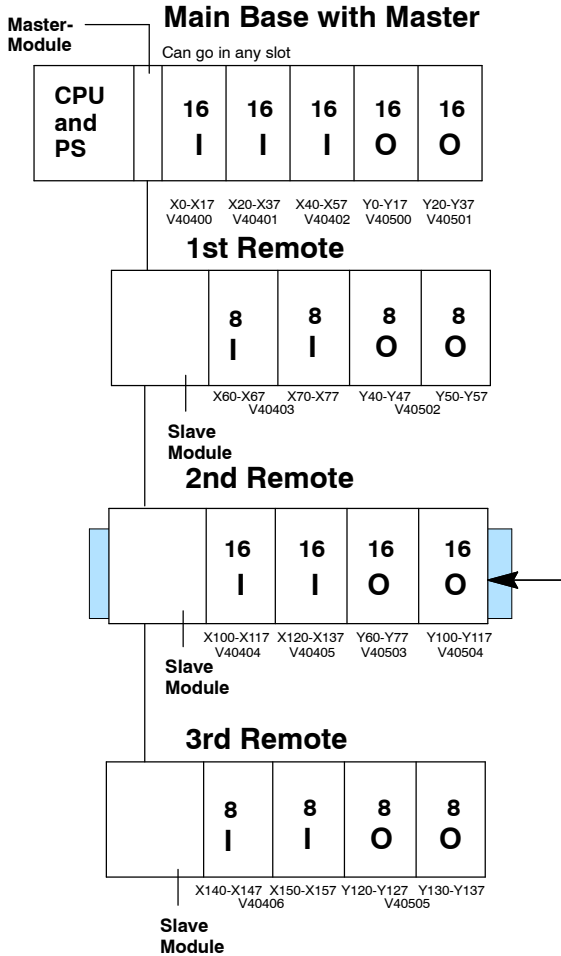

Remote Slave Worksheet

Remote Base Address 2 (Choose 1-7)

Slot Number	Module Name	INPUT		OUTPUT	
		Input Address	No. Inputs	Output Address	No. Outputs
0	16ND2	X100	16		
1	16ND2	X120	16		
2	16TD1			Y60	16
3	16TD1			Y100	16
4					
5					
6					
7					

Input Bit Start Address: X100 V-Memory Address: V 40404

Total Input Points Committed 32

Output Bit Start Address: Y60 V-Memory Address: V 40503

Total Output Points Committed 32

Starting Addresses From Appendix B = V40404 Input V40503 Output

Remote Slave #1 has points X060 to X077 allocated to its inputs and points Y040 to Y057 allocated to its outputs. This means the starting address for the *second remote base inputs* is X100 (or higher) and the starting address for *outputs* is Y060 (or higher). Turning to Appendix B, you look up the V-memory addresses for these points in their respective input and output memory address charts, you find the starting address for the inputs to be V40404. On the output chart, you find cross-reference 060 with V40502. These numbers are filled in at the bottom of the worksheet.

Now let's do the same thing for *third* remote I/O base.

Filling Out the Remote Slave Worksheet for Slave #3

The following remote slave worksheet has been filled in to match the third remote I/O base of the example system.

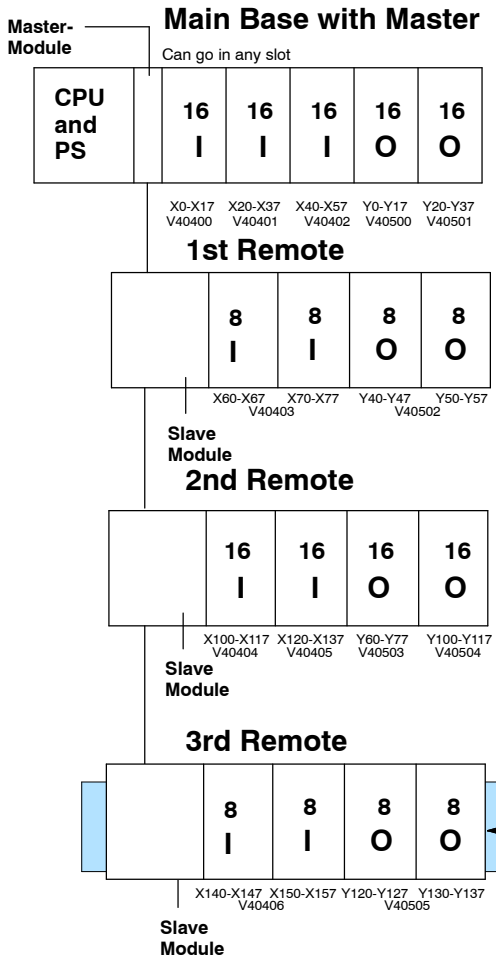

Remote Slave Worksheet

Remote Base Address 3 (Choose 1-7)

Slot Number	Module Name	INPUT		OUTPUT	
		Input Address	No. Inputs	Output Address	No. Outputs
0	08ND3S	X140	8		
1	08ND3S	X150	8		
2	08TD1			Y120	8
3	08TD1			Y130	8
4					
5					
6					
7					

Input Bit Start Address: X140 V-Memory Address: V 40406

Total Input Points Committed 16

Output Bit Start Address: Y120 V-Memory Address: V 40505

Total Output Points Committed 16

Starting Addresses From Appendix B = V40406 Input V40505 Output

Remote Slave #2 has points X100 to X137 allocated to its inputs and points Y100 to Y117 allocated to its outputs. This means the starting address for the *third base inputs* is X140 (or higher) and the starting address for *outputs* is Y120 (or higher). Turning to Appendix B, you look up the V-memory addresses for these points in their respective input and output memory address charts, you find the starting address for the inputs to be V40406. On the output chart, you find cross-reference 120 with V40505. These numbers are filled in at the bottom of the worksheet.

Calculating the Power Budget

Managing your Power Resource

When determining the types and quantity of I/O modules you will be using in the DL405 system, it is important to remember there is a limited amount of power available from the power supply to the system. We have provided a chart to help you easily see the amount of power you will have with your CPU, Expansion Unit or Remote Slave selection. At the end of this section you will also find an example of power budgeting and a worksheet showing sample calculations.

If the I/O you chose exceeds the maximum power available from the power supply you can resolve the problem by adding another base--either remote or expansion.

WARNING: It is *extremely* important to calculate the power budget correctly. If you exceed the power budget, the system may operate in an unpredictable manner which may result in a risk of personal injury or equipment damage.

CPU Power Specifications

The following chart shows the amount of current **supplied** by the the DL405 CPU, Expansion unit or Remote Slave unit. Use this to calculate the power budget for your system. The Auxiliary 24V Power Source mentioned in the table can be used to power field devices or DL405 modules that require an external 24VDC. (Check the terminal strip wiring diagrams shown in Chapter 3 for the location of these terminals.)

CPU	5V Current Supplied in mA.	Auxiliary 24V Power Source Current Supplied in mA.	Remote and Expansion Units	5V Current Supplied in mA.	Auxiliary 24V Power Source Current Supplied in mA.
D4-430	3700	400	D4-EX	4000	400
D4-440	3700	400	D4-EXDC	4000	None
D4-440DC-1	3700	None	D4-RS	3700	400
D4-440DC-2	3700	None	D4-RSDC	3700	None

Module Power Requirements

The chart on the next page shows the amount of maximum current **required** for each of the DL405 modules. Use this information to calculate the power budget for your system. If an external 24VDC power source is required, you can use the built-in 24VDC auxiliary supply from the CPU or the Remote Slave as long as the power budget is not exceeded.

NOTE: Not all of the modules shown in the following table can be used in a Remote base. Check page 2-9 for module placement restrictions.

Device	5V Current Required in mA.	External 24V Current Required in mA.
I/O Bases		
D4-04B	80	None
D4-04BNX	80	None
D4-06B	80	None
D4-06BNX	80	None
D4-08B	80	None
D4-08BNX	80	None
DC Input Modules		
D4-08ND3S	100	None
D4-16ND2	150	None
D4-16ND2F	150	None
D4-32ND3-1	150	None
D4-32ND3-2	150	None
D4-64ND2	300 (max)	None
AC Input Modules		
D4-08NA	100	None
D4-16NA	150	None
AC/DC Input Modules		
D4-16NE3	150	None
F4-08NE3S	90	None
DC Output Modules		
D4-08TD1	150	35
D4-16TD1	200	125
D4-16TD2	400	None
D4-32TD1	250	140
D4-32TD1-1	250	140 (15V)
D4-32TD2	350	120 / (4A max including loads)
D4-64TD1	800 (max)	None
AC Output Modules		
D4-08TA	250	None
D4-16TA	450	None
Relay Output Modules		
D4-08TR	550	None
F4-08TRS-1	575	None
F4-08TRS-2	575	None
D4-16TR	1000	None

Device	5V Current Required in mA.	External 24V Current Required in mA.
Analog Modules		
D4-04AD	200	200
F4-04ADS	270	120
F4-08AD	75	90
D4-02DA	250	300
F4-04DA	120	180
F4-08THM-N	75	40
Remote I/O		
D4-RM	300	None
D4-SM	300	None
D4-SS-88	None	100 (250 with HPP)
D4-SS-106	None	100 (250 with HPP)
D4-SS-16T	None	100 (250 with HPP)
D4-SS-16N	None	100 (250 with HPP)
F4-SDS	110	None
Communications and Networking		
D4-DCM	500	None
F4-MAS-MB	235	None
F4-SLV-MB	235	None
F4-SLV-MBR	350	None
F4-SLV-TW	250	None
F4-SDN	235	None
FA-UNICON	None	65
CoProcessors™		
F4-CP128	305	None
F4-CP512	235	None
F4-CP128-T	350	None
F4-CP128-R	350	None
Specialty Modules		
D4-INT	100	None
D4-HSC	300	None
F4-16PID	160	None
F4-08MPI	225	170
D4-16SIM	150	None
F4-4LTC	160	None
Programming		
D4-HPP	320	None
Operator Interface		
DV-1000	150	None

Power Budget Calculation Example

The following example shows how to calculate the power budget for the first slave unit of a remote I/O system.

Slave #	Module Type	5 VDC (mA)	Auxiliary Power Source 24 VDC Output (mA)
<u>1</u>			
Remote Slave Used	D4-RS	3700	400
Slot 0	D4-08ND3S	100	0
Slot 1	D4-08ND3S	100	0
Slot 2	D4-08TD1	150	0
Slot 3	D4-08TD1	150	0
Slot 4			
Slot 5			
Slot 6			
Slot 7			
Other			
Base	D4-08B	80	0
Maximum power required		580	0
Remaining Power Available		$3700 - 580 = 3120$	$400 - 0 = 400$

- Using the tables at the beginning of the Power Budgeting section of this chapter fill in the information for the CPU/Remote Slave, I/O modules, and any other devices that will use system power including devices that use the 24 VDC output. Pay special attention to the current supplied by either the CPU, Expansion Unit, and Remote Slave since they do differ. Devices which fall into the "Other" category are devices such as the Base and the Handheld programmer which also have power requirements but do not directly plug into the base.
- Add the current columns starting with Slot 0 and put the total in the row labeled "Maximum power required".
- Subtract the row labeled "Maximum power required" from the row labeled "CPU/Expansion Unit/Remote Slave Used". Place the difference in the row labeled "Remaining Power Available".
- If "Maximum Power Required" is greater than "CPU/Expansion Unit/Remote Slave Used" in any of the three columns, the power budget will be exceeded. It will be unsafe to use this configuration and you will need to restructure your I/O configuration.

Which Modules Can Go In the Remote Bases

The most commonly used I/O modules for the DL405 system (AC, DC, AC/DC, Relay and Analog) can be used in the remote I/O bases. The table below lists by category those modules that can be used in the remote I/O base.

Module/Unit	Remote Base
CPU's	No
Expansion Units	No
DC Input Modules	Yes
AC Input Modules	Yes
AC/DC Input Modules	Yes
DC Output Modules	Yes
AC Output Modules	Yes
Relay Output Modules	Yes
Analog Modules	Yes
Remote I/O	
Remote Master	No
Remote Slave Unit	CPU Slot Only
Slice Master	No
Communications and Networking Modules	No
CoProcessor Modules	No
Specialty Modules	
Interrupt	No
High Speed Counter	No
PID	No
I/O Simulator	Yes
Filler	Yes

NOTE: The User Manual for Analog I/O Modules discusses scan times for updating analog I/O data for modules that have been installed in *local or expansion bases*. Please be aware that the **scan times for updating are different for remote I/O modules installed in remote bases**. The CPU scan is asynchronous with the remote scan by the master module. Thus, an analog input module installed in a remote base, for example, may not have its data updated by the CPU "once every scan per channel" as stated in the user manual. The CPU scan may, in fact, cycle several times while the remote scan is taking place. You should take this into account in applications where the timing is critical.

Installation & Field Wiring Guidelines

In This Chapter. . . .

- Introduction
 - Setting the Front Rotary Switch
 - Setting the Rear DIP Switches
 - Inserting the Module in the Base
 - Connecting the Wiring
-

Introduction

NOTE: It is advised that you read the previous chapter on “Defining Your I/O System” before you install your remote master and slave units. The decision making process explained in that chapter will help you understand the rotary switches and dip switches covered in this chapter. It will also help you with writing your ladder logic in the next chapter.

4 Easy Steps:

There are four easy steps to install either a D4-RM, D4-RS or D4-RSDC module:

- Step1 - Set the address on the front rotary switch (i.e. 1 through 7).
- Step2 - Set the function code and baud rate on the rear DIP switch.
- Step3 - With no power applied, insert the module into the base.
- Step 1 With no power applied, connect the wiring.

The text that follows will cover each of these steps in detail.

Step One: Setting the Front Rotary Switch

Both the remote master and slave have a small rotary switch on the front of their enclosure. It has the label, "UNIT ADRS" beside it. To access it you must remove the protective cover. This switch is easily rotated using a flathead screwdriver.

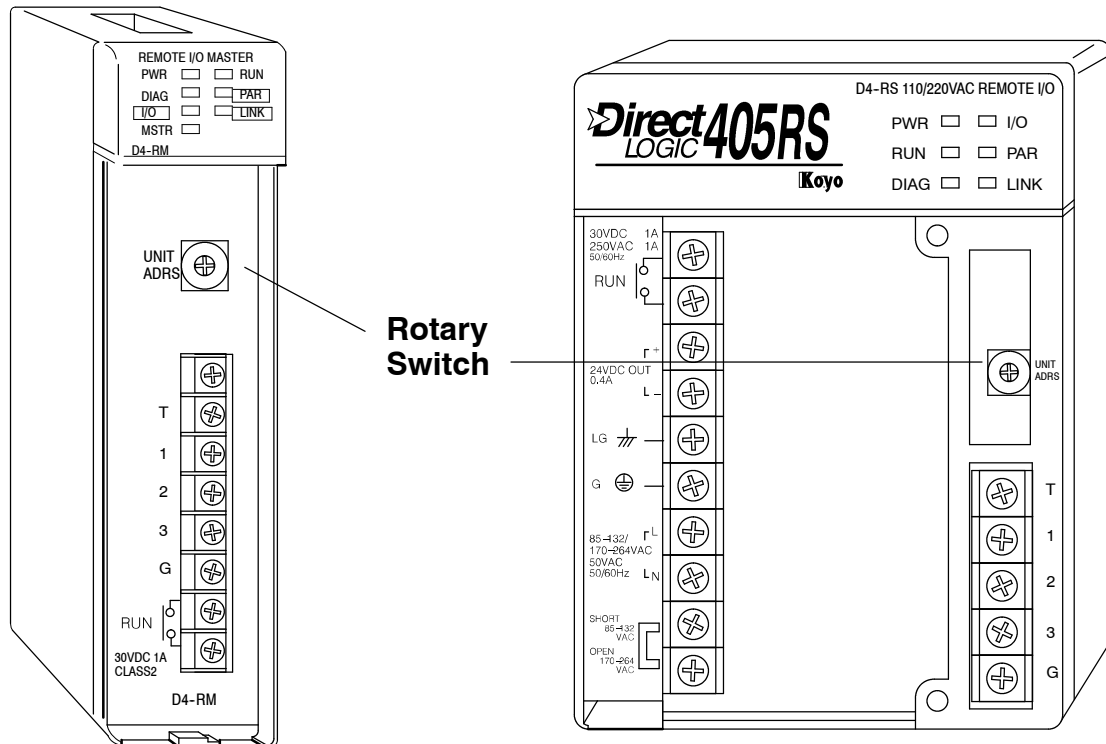

Align the arrow on the switch to 0 if you plan to use the module as a **master** (D4-RM only). Set it to any number 1-7 if you plan for it to be a **slave** (D4-RS, or D4-RSDC). Two slaves cannot have the same number if they are linked to the same master. **Always use consecutive numbers for slaves, starting with Address 1--don't skip numbers.**

Step Two: Setting the Rear DIP Switches

On the rear of each module is an opening with a 4-position DIP switch. These switches must be set to indicate whether the module is a slave or a master and to specify the proper baud rate (either 38.4 kBaud or 19.2 kBaud).

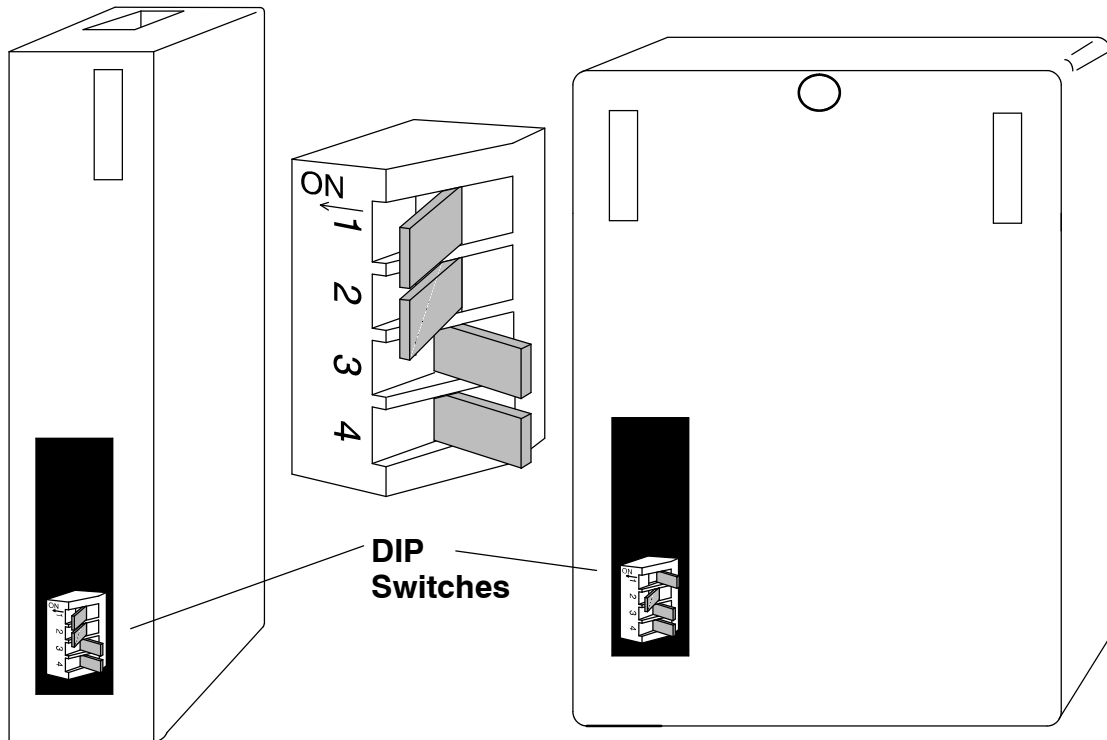

Chart for DIP Switch Settings

Position	1	2	3	4
Master	Always ON	ON=38.4 kBaud OFF=19.2 kBaud	Always OFF	Always OFF
Remote	Always OFF	ON=38.4 kBaud OFF=19.2 kBaud	Always OFF	Always OFF

An arrow showing the ON position is visible on the switch beside Position 1.

Position 1 is in the ON position for the DM4-RM. Position 1 of the DIP switch for the D4-RS and D4-RSDC is always set to the OFF position. Remember, only the D4-RM can be used as a master.

Position 2 is ON if you want the faster baud rate, 38.4 kBaud. It is OFF if you want the slower 19.2 kBaud. Of course, Position 2 of the master and slaves have to be set to the same setting in order to communicate.

Positions 3 and 4 are not used and are always set in the OFF position.

Example Showing Proper Setting of Switches

Here's the way Steps 1 and 2 would be carried out for the example system we established in Chapter 2 if we decided to operate at 38.4 kBaud:

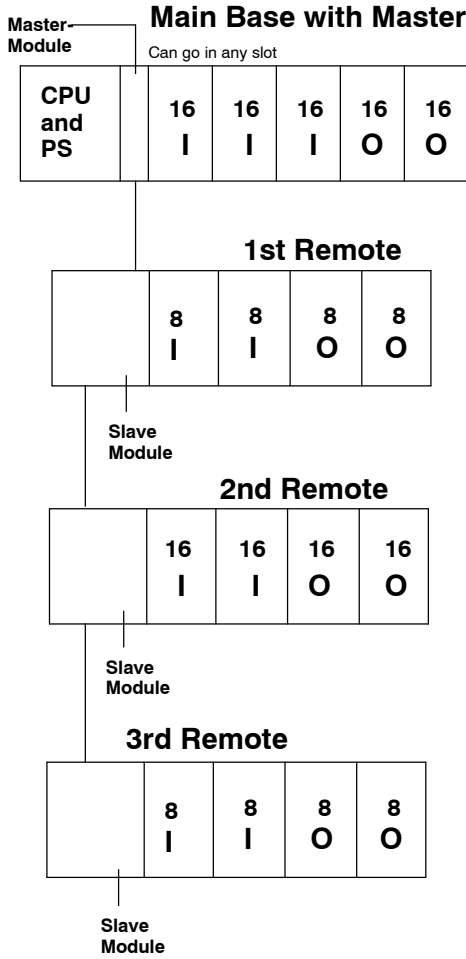

Rotary Switch

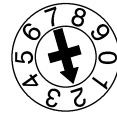
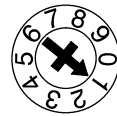
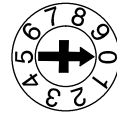

Dip Switch

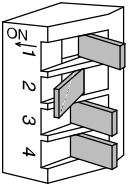
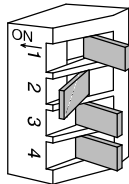
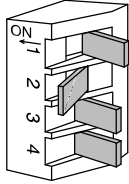
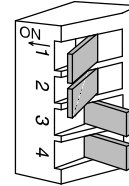

ON=Master
ON =38.4 kBaud
OFF=Not Used
OFF=Not Used

OFF=Remote
ON =38.4 kBaud
OFF=Not Used
OFF=Not Used

OFF=Remote
ON =38.4 kBaud
OFF=Not Used
OFF=Not Used

OFF=Remote
ON =38.4 kBaud
OFF=Not Used
OFF=Not Used

Chart for DIP Switch Settings

Position	1	2	3	4
Master	Always ON	ON=38.4 kBaud OFF=19.2 kBaud	Always OFF	Always OFF
Remote	Always OFF	ON=38.4 kBaud OFF=19.2 kBaud	Always OFF	Always OFF

Step Three: Inserting the Module in the Base

The D4-RM can go into any slot in the CPU base. The D4-RS or D4-RSDC must be inserted in the CPU slot of the remote base(s).

NOTE: Don't forget to check your total “**power budget**” and make sure your total current drawn by the remote modules and other I/O modules do not exceed the total amount allowable for the CPU you are using. See Chapter 2 of this manual or your DL405 User Manual for instructions on how to compute your power budget.

WARNING: To minimize the risk of electrical shock, personal injury, or equipment damage, always disconnect the system power before installing or removing any system component.

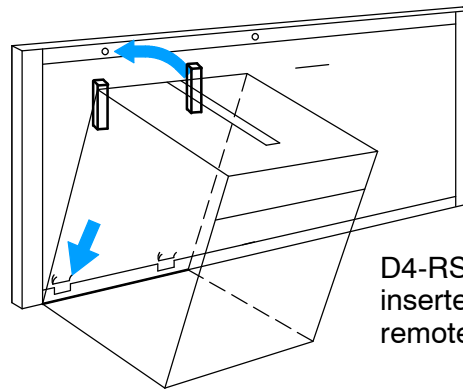

D4-RS or D4-RSDC must be inserted in the CPU slot of the remote base.

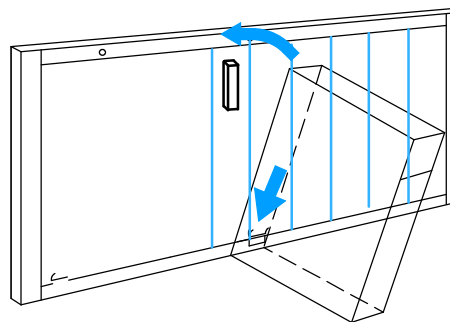

D4-RM can go into any slot in the local base except the CPU slot.

Notice the modules have plastic tabs at the bottom and a screw at the top. With the module tilted slightly forward, hook the plastic tab on the module into the notch on the base. Next, gently push the top of the module back toward the base until it is firmly seated into the base. Now tighten the screw at the top of the module to secure the module to the base.

Step Four: Connecting the Wiring

General Wiring Guidelines

You should consider the following wiring guidelines when wiring your system.

- Step1 - There is a limit to the size of wire the modules can accept. 16 AWG to 24 AWG is recommended. Smaller AWG is acceptable.
- Step2 - Always use a continuous length of wire, do not combine wires to attain a needed length.
- Step3 - Use the shortest possible cable length.
- Step4 - Where possible, use wire trays for routing.
- Step5 - Avoid running wires near high energy wiring.
- Step6 - Avoid running input wiring in close proximity to output wiring where possible.
- Step7 - To minimize voltage drops when wires must run a long distance, consider using multiple wires for the return line.
- Step8 - Where possible, avoid running DC wiring or communication cabling in close proximity to AC wiring.
- Step9 - Avoid creating sharp bends in the wires.
- Step 1 - Label all wires.

Power Connections for the D4-RS or D4-RSDC

To access the power terminals of the D4-RS or D-RSDC modules, you must first remove the large protective cover from the front of the enclosure. **Without power being applied**, connect the line voltage or DC power supply wires to the appropriate terminals. Also connect the safety earth ground.

D4-RS

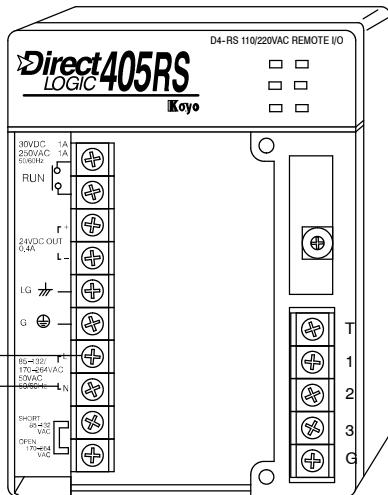

D4-RSDC

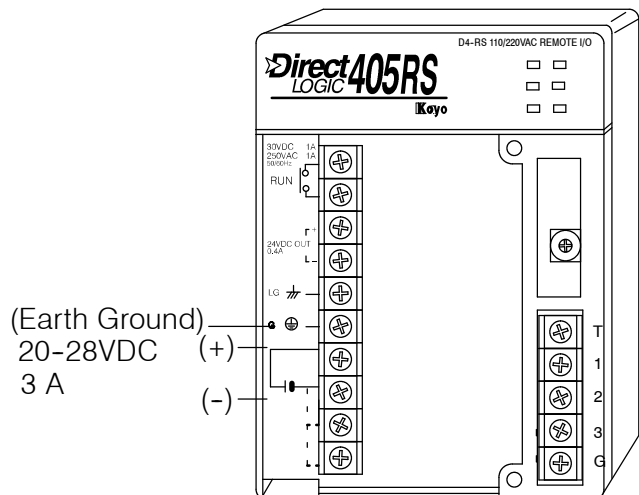

Cabling Between the Master and Slaves

The diagram shown below depicts the cabling between the master and its slaves. This is twisted pair cable. The two inner wires are connected to terminals 1 and 2 of each module. The shield wire is connected to terminal 3. *Do not connect the shield wire to the Ground terminal. Make sure the the connections between master and all slaves are always 1 to 1, 2 to 2 and 3 to 3.*

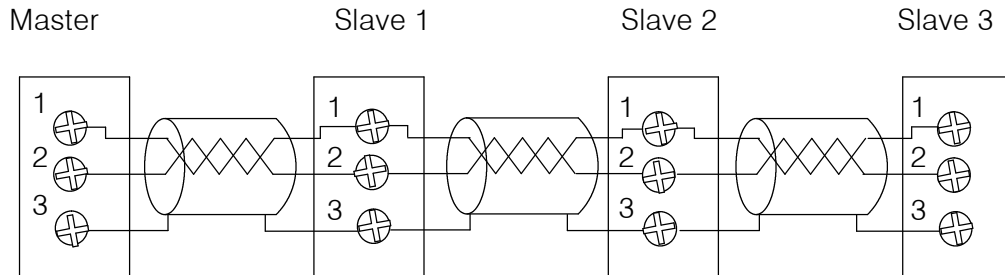

Termination Resistors

At each end of a master/slave system, it is necessary to have a “termination resistor” to prevent signal reflections from interfering with the communications. Although the modules have a 330 ohm resistor built in for this purpose, there are three options to be considered:

**Option 1:
Use Internal Resistor Only**

With this configuration, you use the internal resistor of the module to provide all the terminating resistance necessary. A jumper wire is placed between the terminating terminal and terminal 1.

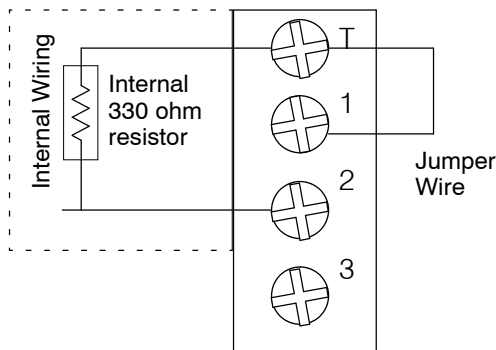

**Option 2:
Use Internal Resistor and Balance Resistor**

To better match the impedance of the cabling, you can elect not use the internal resistor; and instead, use a resistor of your choice externally. This is connected between terminals 1 and 2. You do not use the jumper wire in this case.

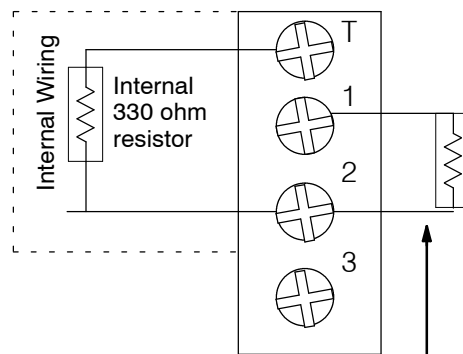

You add your own resistor, using a resistor between 100 and 500 ohms.

**Option 3:
External Resistor in Series**

With this option, you use an external resistor in series with the internal resistor. The sum resistance should match the cabling impedance.

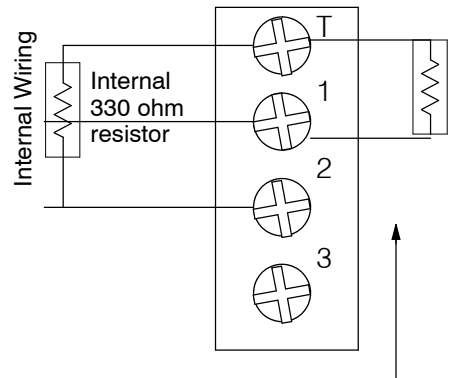

You use an external resistor in series with the internal resistor.

**Connecting the
Run Output Circuit**

D4-RM, D4-RS, and D4-RSDC modules have a normally open relay that closes when communication is successfully made between the master and its slaves. Each module has its own LED indicator that glows when successful communication has been accomplished.

The Run Output relay can be wired to a 24 VDC sinking input module so that ladder logic can be written to monitor the communications link. The bottom two terminals for the terminal block are where the wires are connected from the input module.

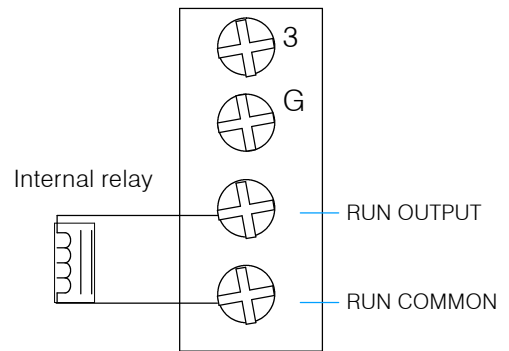

Installation/Wiring

If the RUN relay in the master goes OFF, then the RUN relay in all of the slaves will be taken off-line also.

If you choose to wire an input (say, X10) from the Run Output, it is very easy to include a rung of logic to sound an alarm or to stop a process when communication problem occurs:



Writing the Setup Program

In This Chapter. . . .

- Getting Started with Your Programming
 - Writing Your Remote I/O Setup
 - Special Relays used for Remote I/O
 - How to Use the Special Relays
-

Getting Started with Your Programming

You can write your program using either a handheld programmer or PC loaded software such as **DirectSOFT**. The examples that follow will show you how this is done using **DirectSOFT**.

To get started, enter **DirectSOFT** and carry out the normal **DirectSOFT** setup procedures for communicating with your DL405 CPU. If you do not know how to do this, refer to your **DirectSOFT** Manual. Chapter 11 of your DL405 User Manual also has a very good coverage of the basic commands available and examples of how the commands are used for writing general ladder logic. We will be showing you in this chapter only those commands that pertain to setting up your remote I/O initialization and its successful utilization.

First open **DirectSOFT** from Windows and establish a link with your CPU. Then enter the Edit Mode for programming. You should now be looking at a screen similar to the one shown below:

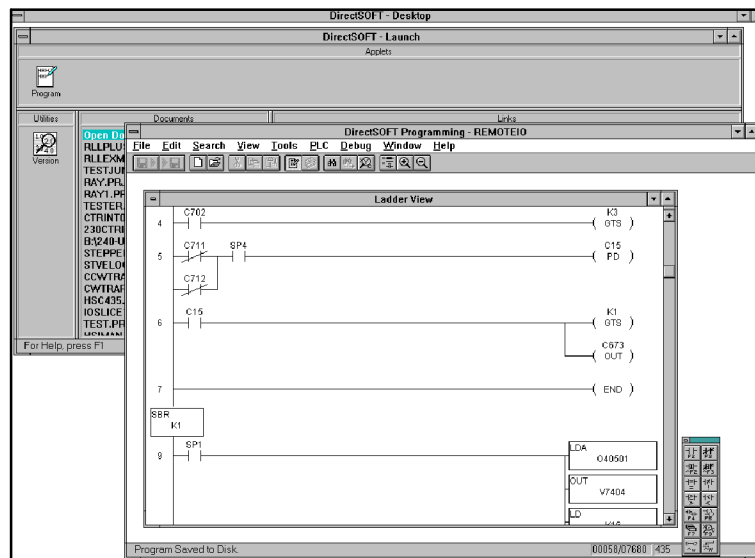

The **DirectSOFT** window shown above depicts a program that has already been written. Your window, of course, will be empty when you first enter it. The pages that follow will show you how to write each part of your initialization program.

Writing Your Remote I/O Setup

Step 1: Decide How You Are Going to Call Your Program

Is your setup logic going to be in the main program body or is it going to be in a subroutine? If you have a DL430, the decision is made for you. The DL430 cannot handle the GTS command for calling a subroutine; and so, you have to write the code in the main body. The DL440, on the other hand, does include the GTS command.

A subroutine for your remote I/O setup has an advantage over writing the code into the program's main body. Some remote I/O setup logic becomes quite lengthy. By putting the setup in a subroutine, you don't have to scroll through extra logic during routine troubleshooting procedures. If you are using the DL440, we advise you to use a subroutine for your remote I/O initialization. Here's how:

Using the GTS Command for the DL440

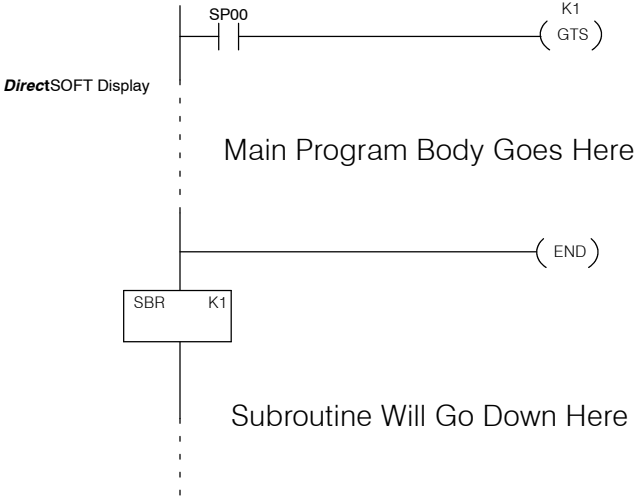

NOTE: Set Retentive Ranges so that C670 - C737 and V7404 - V7477 are **not** retentive.

**Step 2:
Write the Setup
Logic for Each
Remote Base**

Whether you choose to write the remote I/O setup program as a subroutine or as a part of the main program, the procedure is still the same. You have two things you have to do:

- Tell the CPU where to read and write the remote I/O points in memory. This is done with the use of “address pointers”.
- Tell the CPU how many points are located in each base.

You can use your worksheets to assist you. In the diagram below, you see how the starting addresses for the points in each remote base (from the tables in Appendix B) are mapped with the proper reserved memory pointers. The chart at the bottom of the page shows the pointer addresses. Notice that the number of points goes in the address immediately following the pointer for the start address. A combination of LDA and OUT commands are used to load and map the V40xxx address into the proper V74xx address. The LD and OUT commands are used to load the number of remote points for each remote base, by placing the number in the address immediately following its pointer. The chart at the bottom also shows the memory locations for storing the number of I/O points for each remote base.

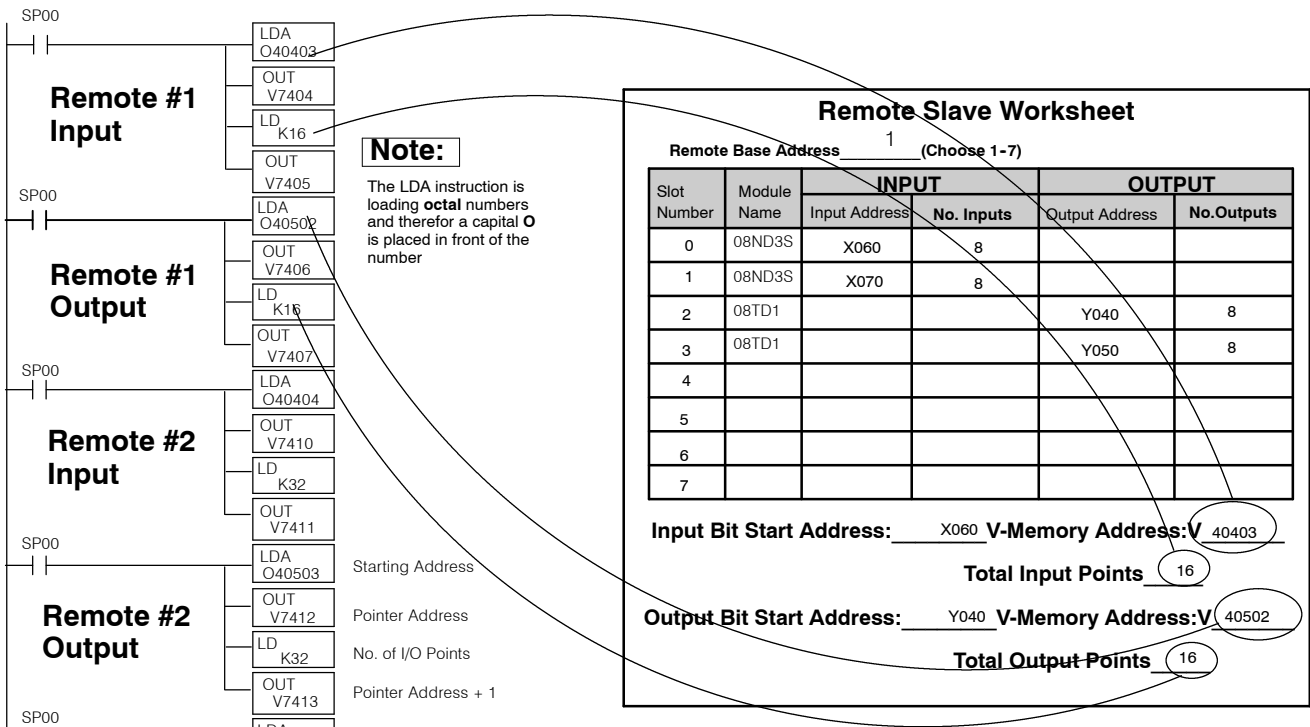

Setup Programming

Table of Reserved Memory for Remote I/O Setup

Slave	First Master Module				Second Master Module			
	Input Address	Number of Input Pts	Output Address	Number of Output Pts	Input Address	Number of Input Pts	Output Address	Number of Output Pts
1	V7404	V7405	V7406	V7407	V7444	V7445	V7446	V7447
2	V7410	V7411	V7412	V7413	V7450	V7451	V7452	V7453
3	V7414	V7415	V7416	V7417	V7454	V7455	V7456	V7457
4	V7420	V7421	V7422	V7423	V7460	V7461	V7462	V7463
5	V7424	V7425	V7426	V7427	V7464	V7465	V7466	V7467
6	V7430	V7431	V7432	V7433	V7470	V7471	V7472	V7473
7	V7434	V7435	V7436	V7437	V7474	V7475	V7476	V7477

Tell the CPU That You Are Finished With the Setup

Once you have decided on the starting addresses and the reserved memory locations for each remote base, you have to zero out all of the reserved memory locations you are not going to use and then tell the CPU that you are finished with the setup. If you don't use the FILL command to insert zero's in the unused areas, the CPU will assume that every pointer address V7404 through V7477 is pointing to a read or write start address. This could cause problems. You may have garbage in these locations--at the very least, its going to take up unnecessary scan time.

The easiest way to fill the unused memory locations with zeros is to do it first, before loading your table setup. Then you overwrite those memory locations used during your table setup, and everything else is zeros, as required. The example below approaches the problem this way.

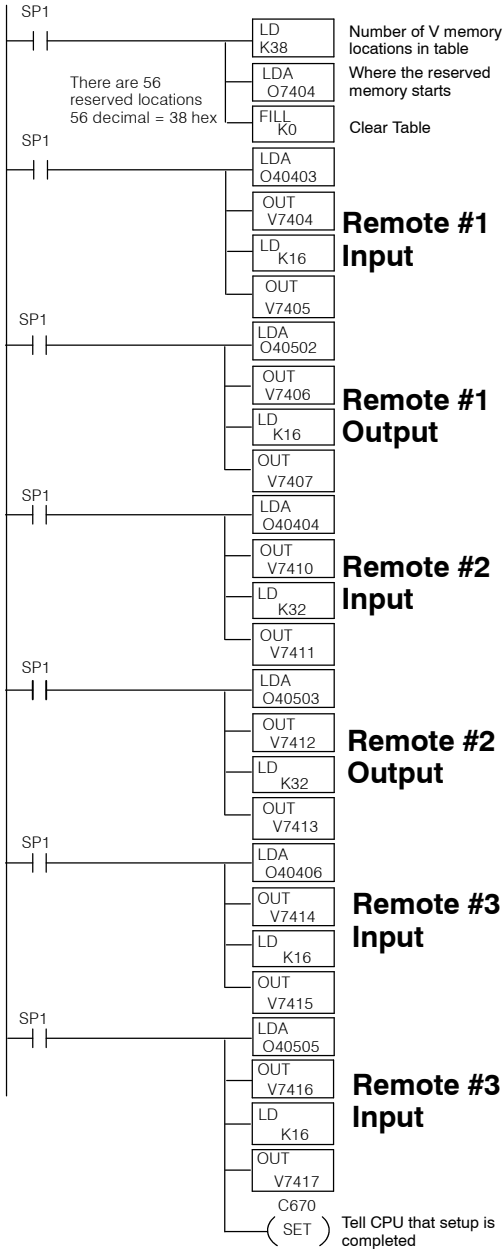

EXAMPLE:
38.4 kBaud, D4-440

Step 1: Design the Remote I/O System

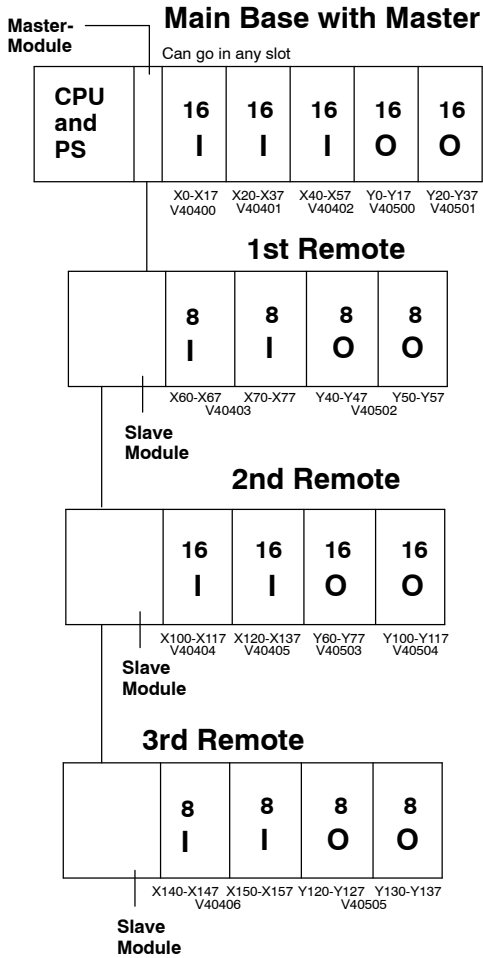

Remote Slave Worksheet

Remote Base Address 1 (Choose 1-7)

Slot Number	Module Name	INPUT		OUTPUT	
		Input Address	No. Inputs	Output Address	No. Outputs
0	08ND3S	X060	8		
1	08ND3S	X070	8		
2	08TD1			Y040	8
3	08TD1			Y050	8
4					
5					
6					
7					

Input Bit Start Address: X060 V-Memory Address:V 40403

Total Input Points 16

Output Bit Start Address: Y040 V-Memory Address:V 40502

Total Output Points 16

Remote Slave Worksheet

Remote Base Address 2 (Choose 1-7)

Slot Number	Module Name	INPUT		OUTPUT	
		Input Address	No. Inputs	Output Address	No. Outputs
0	16ND2	X100	16		
1	16ND2	X120	16		
2	16TD1			Y060	16
3	16TD1			Y100	16
4					
5					
6					
7					

Input Bit Start Address: X100 V-Memory Address:V 40404

Total Input Points 32

Output Bit Start Address: Y060 V-Memory Address:V 40503

Total Output Points 32

Remote Slave Worksheet

Remote Base Address 3 (Choose 1-7)

Slot Number	Module Name	INPUT		OUTPUT	
		Input Address	No. Inputs	Output Address	No. Outputs
0	08ND3S	X140	8		
1	08ND3S	X150	8		
2	08TD1			Y120	8
3	08TD1			Y130	8
4					
5					
6					
7					

Input Bit Start Address: X140 V-Memory Address:V 40406

Total Input Points 16

Output Bit Start Address: Y120 V-Memory Address:V 40505

Total Output Points 16

Note:

The Remote Slave Worksheet is found in Appendix A.

Step 2: Set the Hardware

Step 3: Write the Setup Program

Table for setting DIP switch

Position	1	2	3	4
Master	Always ON	ON=38.4kB OFF=19.2kB	Always OFF	Always OFF
Remote	Always OFF	ON=38.4kB OFF=19.2kB	Always OFF	Always OFF

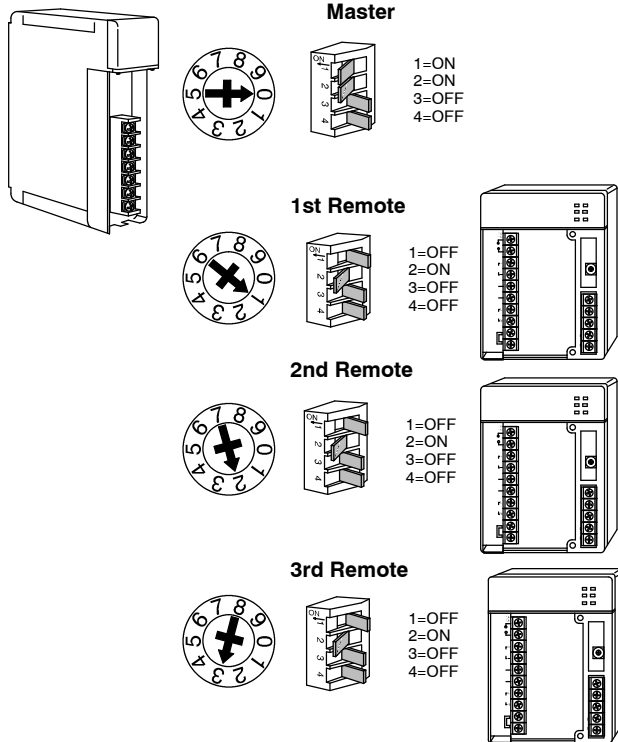
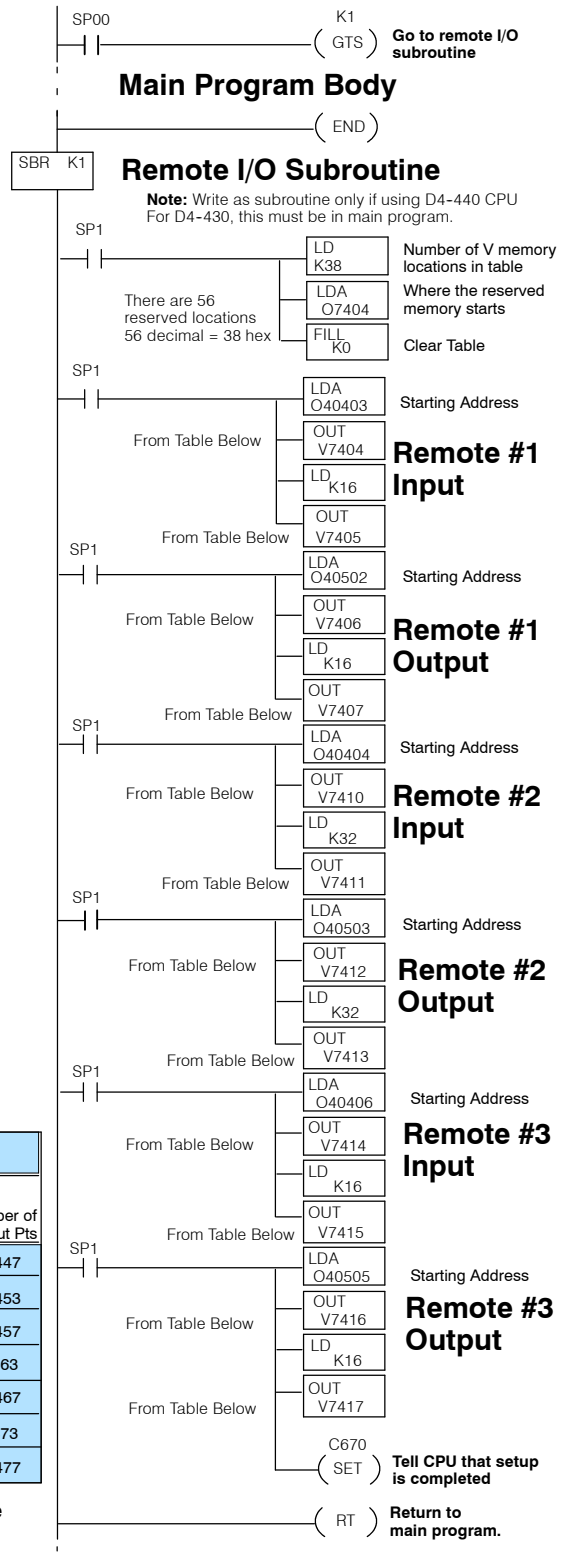

Table of Reserved Memory for Remote I/O Setup

First Master Module					Second Master Module			
Slave	Input Address	Number of Input Pts	Output Address	Number of Output Pts	Input Address	Number of Input Pts	Output Address	Number of Output Pts
1	V7404	V7405	V7406	V7407	V7444	V7445	V7446	V7447
2	V7410	V7411	V7412	V7413	V7450	V7451	V7452	V7453
3	V7414	V7415	V7416	V7417	V7454	V7455	V7456	V7457
4	V7420	V7421	V7422	V7423	V7460	V7461	V7462	V7463
5	V7424	V7425	V7426	V7427	V7464	V7465	V7466	V7467
6	V7430	V7431	V7432	V7433	V7470	V7471	V7472	V7473
7	V7434	V7435	V7436	V7437	V7474	V7475	V7476	V7477

= unused memory for this example

RLL Program



Special Relays Used for Remote I/O

The remote I/O system has several relays that are used with your system. On the previous pages, you saw how C670 is used to tell the CPU that all of the mapping has taken place. Below is a complete list of all of these relays:

Function of Relay	First Master Relay (s)	Second Master Relay (s)	Description
Setup Complete (Mandatory)	C670	C674	These two relays are used to tell the CPU that your program has finished doing all of its remote I/O mapping. When finished, the CPU continues the rest of its scan cycle.
Locate Error	C700-C707	C720-C727	These relays are flags to let you know that a communication error has occurred. If set, there has been an error. This method of error detection helps locate the error. The last digit of the relay number indicates base unit. For example, C723 refers to the third slave unit of the second master. If it were C705, it would be indicating that the fifth slave unit of the first master module is not communicating.
I/O Status On Error (Save or Clear)	C671	C675	These two relays are for determining whether you want the remote I/O points to be set to zero when an error occurs, or whether you want to save the current I/O settings.
Restart But Ignore Part of System Causing Error	C673	C677	You may want to continue updating I/O data from remote I/O bases even if one of them has caused a communications error. These two relays allow you to take the bad base off line and to restart the system before the error is cleared.
Communications OK	C710-C717	C730-C737	These flags tell you if a particular base unit is ready for communication. The last digit of the relay number indicates the base unit. For example, C711 refers to the first slave unit of the first master. If it were C735, it would be indicating the communications status of the fifth slave unit of the second master module.

How to Use the Special Relays

Here are some example uses of these relays and an added explanation for each of the relays discussed on the previous page:

C670/C674: Setup Complete (Mandatory)

These are setup flags for **marking the end of your ladder logic** that sets up your remote I/O configuration. It should be the last rung of your setup. It should always follow your FILL command that zero's out all of the unused pointer addresses.

Example:

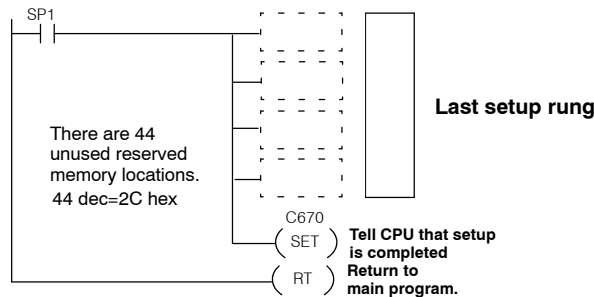

C700 to C707 and C720 to C727: Locate Communications Error (Optional)

C700 to C707 are assigned to the 1st Master. C720 to C727 are assigned to the 2nd Master. The last digit of these relays indicates the base unit number. Remember that the CPU base is always Base Unit #0. The remote bases can be any number 1 through 7. For example, C721 refers to the 2nd Master, 1st Remote Base. These relays will be set when there is a **communications error** between the respective master and slave assigned to the relay number.

Example:

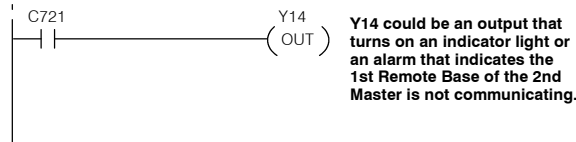

C671/C675: I/O Status On Error (Optional)

C671 is assigned to the 1st Master. C675 is assigned to the 2nd Master. When any master can't talk to one or more of its slaves, the "link" LED will illuminate on the affected module and the system will stop updating the remote I/O status in the CPU. You have several options at that point. One such option is either to **save the last known I/O status** that is in the CPU's memory image area, or to **write a zero to each point**. If these flags are OFF when the error occurs, all current I/O will be zeroed.

Example:

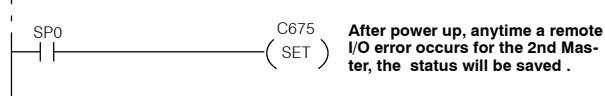

C673/C677 Error/Restart But Ignore Problem Area (Optional)

When a relay with C700 to C707 or C720 to C727 is set to indicate a communications error, you can use either or both C673 (for I/O belonging to the 1st master) and C677 (for I/O belonging to the 2nd master) as a method for having the CPU **skip the scanning** of the I/O register associated with a particular slave unit. Look in the Reserved Memory Table below to find the appropriate V74xx pointer address to match up with the appropriate C7## relay. Both the relay and the pointers are specifically assigned to unique slave units.

Example:

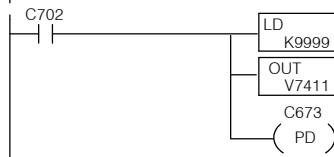

The number 9999 loaded in the pointer address for Slave #2 of the 1st master will tell the CPU to ignore this slave unit during restart after an error. See previous page for proper use of C700 to C707 and C720 to C727.

1st Master			2nd Master	
Slave	Relay	Address Pointer	Relay	Address Pointer
1	C701	V7405	C721	V7445
2	C702	V7411	C722	V7451
3	C703	V7415	C723	V7455
4	C704	V7421	C724	V7461
5	C705	V7425	C725	V7465
6	C706	V7431	C726	V7471
7	C707	V7435	C727	V7475

C710 to C717 and C730 to C737 Communications OK Status (Optional)

C710 to C717 are assigned to the 1st Master. C730 to C737 are assigned to the 2nd Master. The last digit of these relays refers to the base unit number. Remember that the CPU base is always Base Unit #0. The remote bases can be any number 1 through 7. For example C715 refers to the 1st Master, 5th Remote Base. These flags indicate that a particular slave unit is **ready for communicating data** over its twisted pair cable.

Example:



Y27 could be turning on an indicator light when the 5th Remote Base connected to the 1st Remote Master is ready for communications.

**Example of RLL
Using All the
Special Relays**

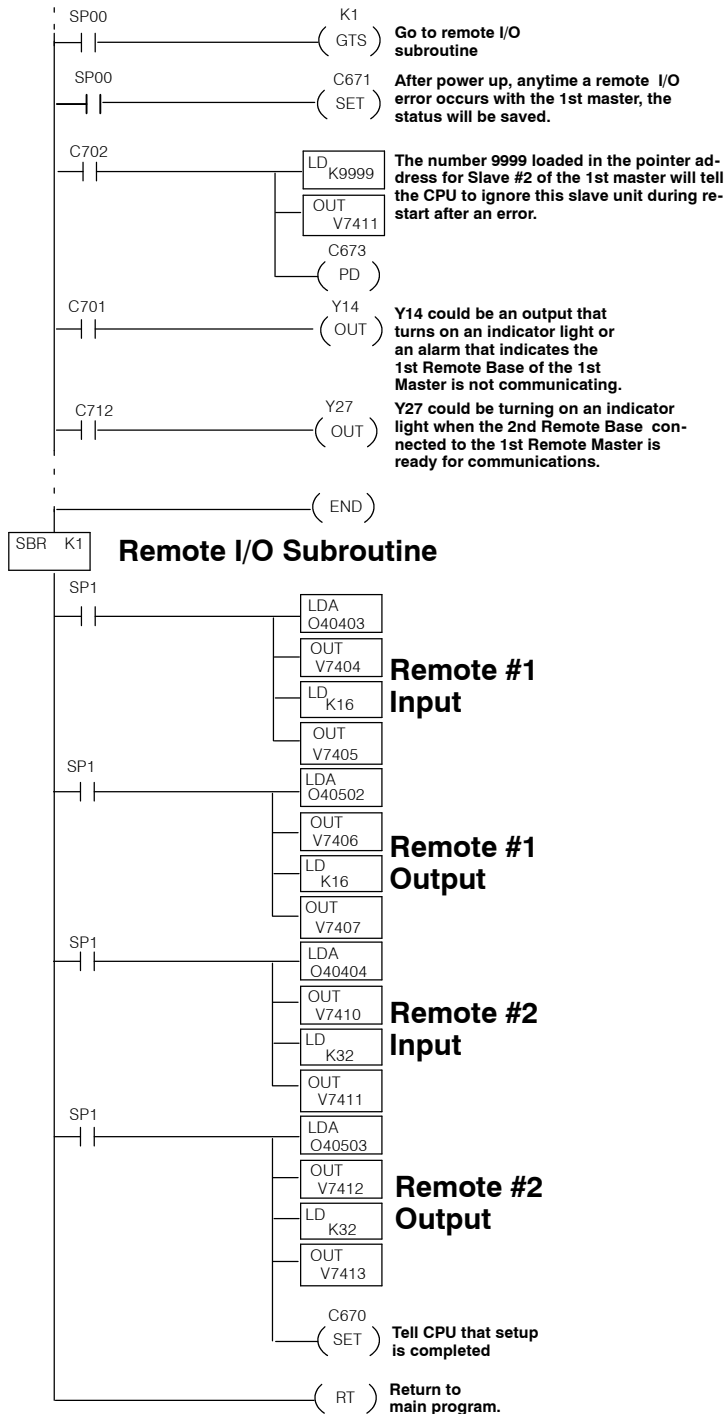

Appendix A

Remote I/O

Worksheet

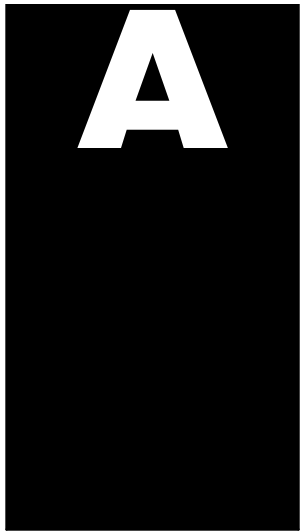

A

Remote Slave Worksheet

Remote Base Address _____ (Choose 1-7)

Slot Number	Module Name	INPUT		OUTPUT	
		Input Address	No. Inputs	Output Address	No. Outputs
0					
1					
2					
3					
4					
5					
6					
7					

Input Bit Start Address: _____ V-Memory Address: V _____

Total Input Points _____

Output Bit Start Address: _____ V-Memory Address: V _____

Total Output Points _____

Appendix B

Reserved Memory Tables

B

Remote Input/Output Global (GX) Addresses

Reserved Memory Tables

MSB															LSB															Address		
17	16	15	14	13	12	11	10	7	6	5	4	3	2	1	0	17	16	15	14	13	12	11	10	7	6	5	4	3	2		1	0
017	016	015	014	013	012	011	010	007	006	005	004	003	002	001	000	017	016	015	014	013	012	011	010	007	006	005	004	003	002	001	000	V40000
037	036	035	034	033	032	031	030	027	026	025	024	023	022	021	020	037	036	035	034	033	032	031	030	027	026	025	024	023	022	021	020	V40001
057	056	055	054	053	052	051	050	047	046	045	044	043	042	041	040	057	056	055	054	053	052	051	050	047	046	045	044	043	042	041	040	V40002
077	076	075	074	073	072	071	070	067	066	065	064	063	062	061	060	077	076	075	074	073	072	071	070	067	066	065	064	063	062	061	060	V40003
117	116	115	114	113	112	111	110	107	106	105	104	103	102	101	100	117	116	115	114	113	112	111	110	107	106	105	104	103	102	101	100	V40004
137	136	135	134	133	132	131	130	127	126	125	124	123	122	121	120	137	136	135	134	133	132	131	130	127	126	125	124	123	122	121	120	V40005
157	156	155	154	153	152	151	150	147	146	145	144	143	142	141	140	157	156	155	154	153	152	151	150	147	146	145	144	143	142	141	140	V40006
177	176	175	174	173	172	171	170	167	166	165	164	163	162	161	160	177	176	175	174	173	172	171	170	167	166	165	164	163	162	161	160	V40007
217	216	215	214	213	212	211	210	207	206	205	204	203	202	201	200	217	216	215	214	213	212	211	210	207	206	205	204	203	202	201	200	V40010
237	236	235	234	233	232	231	230	227	226	225	224	223	222	221	220	237	236	235	234	233	232	231	230	227	226	225	224	223	222	221	220	V40011
257	256	255	254	253	252	251	250	247	246	245	244	243	242	241	240	257	256	255	254	253	252	251	250	247	246	245	244	243	242	241	240	V40012
277	276	275	274	273	272	271	270	267	266	265	264	263	262	261	260	277	276	275	274	273	272	271	270	267	266	265	264	263	262	261	260	V40013
317	316	315	314	313	312	311	310	307	306	305	304	303	302	301	300	317	316	315	314	313	312	311	310	307	306	305	304	303	302	301	300	V40014
337	336	335	334	333	332	331	330	327	326	325	324	323	322	321	320	337	336	335	334	333	332	331	330	327	326	325	324	323	322	321	320	V40015
357	356	355	354	353	352	351	350	347	346	345	344	343	342	341	340	357	356	355	354	353	352	351	350	347	346	345	344	343	342	341	340	V40016
377	376	375	374	373	372	371	370	367	366	365	364	363	362	361	360	377	376	375	374	373	372	371	370	367	366	365	364	363	362	361	360	V40017
417	416	415	414	413	412	411	410	407	406	405	404	403	402	401	400	417	416	415	414	413	412	411	410	407	406	405	404	403	402	401	400	V40020
437	436	435	434	433	432	431	430	427	426	425	424	423	422	421	420	437	436	435	434	433	432	431	430	427	426	425	424	423	422	421	420	V40021
457	456	455	454	453	452	451	450	447	446	445	444	443	442	441	440	457	456	455	454	453	452	451	450	447	446	445	444	443	442	441	440	V40022
477	476	475	474	473	472	471	470	467	466	465	464	463	462	461	460	477	476	475	474	473	472	471	470	467	466	465	464	463	462	461	460	V40023
517	516	515	514	513	512	511	510	507	506	505	504	503	502	501	500	517	516	515	514	513	512	511	510	507	506	505	504	503	502	501	500	V40024
537	536	535	534	533	532	531	530	527	526	525	524	523	522	521	520	537	536	535	534	533	532	531	530	527	526	525	524	523	522	521	520	V40025
557	556	555	554	553	552	551	550	547	546	545	544	543	542	541	540	557	556	555	554	553	552	551	550	547	546	545	544	543	542	541	540	V40026
577	576	575	574	573	572	571	570	567	566	565	564	563	562	561	560	577	576	575	574	573	572	571	570	567	566	565	564	563	562	561	560	V40027
617	616	615	614	613	612	611	610	607	606	605	604	603	602	601	600	617	616	615	614	613	612	611	610	607	606	605	604	603	602	601	600	V40030
637	636	635	634	633	632	631	630	627	626	625	624	623	622	621	620	637	636	635	634	633	632	631	630	627	626	625	624	623	622	621	620	V40031
657	656	655	654	653	652	651	650	647	646	645	644	643	642	641	640	657	656	655	654	653	652	651	650	647	646	645	644	643	642	641	640	V40032
677	76	675	674	673	672	671	670	667	666	665	664	663	662	661	660	677	76	675	674	673	672	671	670	667	666	665	664	663	662	661	660	V40033
717	716	715	714	713	712	711	710	707	706	705	704	703	702	701	700	717	716	715	714	713	712	711	710	707	706	705	704	703	702	701	700	V40034
737	736	735	734	733	732	731	730	727	727	742	724	723	722	721	720	737	736	735	734	733	732	731	730	727	727	742	724	723	722	721	720	V40035
757	756	755	754	753	752	751	750	747	746	745	744	743	742	741	740	757	756	755	754	753	752	751	750	747	746	745	744	743	742	741	740	V40036
777	776	775	774	773	772	771	770	767	766	765	764	763	762	761	760	777	776	775	774	773	772	771	770	767	766	765	764	763	762	761	760	V40037

Standard Input (X) Addresses

MSB															LSB															Address		
17	16	15	14	13	12	11	10	7	6	5	4	3	2	1	0	17	16	15	14	13	12	11	10	7	6	5	4	3	2		1	0
017	016	015	014	013	012	011	010	007	006	005	004	003	002	001	000	017	016	015	014	013	012	011	010	007	006	005	004	003	002	001	000	V40400
037	036	035	034	033	032	031	030	027	026	025	024	023	022	021	020	037	036	035	034	033	032	031	030	027	026	025	024	023	022	021	020	V40401
057	056	055	054	053	052	051	050	047	046	045	044	043	042	041	040	057	056	055	054	053	052	051	050	047	046	045	044	043	042	041	040	V40402
077	076	075	074	073	072	071	070	067	066	065	064	063	062	061	060	077	076	075	074	073	072	071	070	067	066	065	064	063	062	061	060	V40403
117	116	115	114	113	112	111	110	107	106	105	104	103	102	101	100	117	116	115	114	113	112	111	110	107	106	105	104	103	102	101	100	V40404
137	136	135	134	133	132	131	130	127	126	125	124	123	122	121	120	137	136	135	134	133	132	131	130	127	126	125	124	123	122	121	120	V40405
157	156	155	154	153	152	151	150	147	146	145	144	143	142	141	140	157	156	155	154	153	152	151	150	147	146	145	144	143	142	141	140	V40406
177	176	175	174	173	172	171	170	167	166	165	164	163	162	161	160	177	176	175	174	173	172	171	170	167	166	165	164	163	162	161	160	V40407
217	216	215	214	213	212	211	210	207	206	205	204	203	202	201	200	217	216	215	214	213	212	211	210	207	206	205	204	203	202	201	200	V40410
237	236	235	234	233	232	231	230	227	226	225	224	223	222	221	220	237	236	235	234	233	232	231	230	227	226	225	224	223	222	221	220	V40411
257	256	255	254	253	252	251	250	247	246	245	244	243	242	241	240	257	256	255	254	253	252	251	250	247	246	245	244	243	242	241	240	V40412
277	276	275	274	273	272	271	270	267	266	265	264	263	262	261	260	277	276	275	274	273	272	271	270	267	266	265	264	263	262	261	260	V40413
317	316	315	314	313	312	311	310	307	306	305	304	303	302	301	300	317	316	315	314	313	312	311	310	307	306	305	304	303	302	301	300	V40414
337	336	335	334	333	332	331	330	327	326	325	324	323	322	321	320	337	336	335	334	333	332	331	330	327	326	325	324	323	322	321	320	V40415
357	356	355	354	353	352	351	350	347	346	345	344	343	342	341	340	357	356	355	354	353	352	351	350	347	346	345	344	343	342	341	340	V40416
377	376	375	374	373	372	371	370	367	366	365	364	363	362	361	360	377	376	375	374	373	372	371	370	367	366	365	364	363	362	361	360	V40417
417	416	415	414	413	412	411	410	407	406	405	404	403	402	401	400	417	416	415	414	413	412	411	410	407	406	405	404	403	402	401	400	V40420
437	436	435	434	433	432	431	430	427	426	425	424	423	422	421	420	437	436	435	434	433	432	431	430	427	426	425	424	423	422	421	420	V40421
457	456	455	454	453	452	451	450	447	446	445	444	443	442	441	440	457	456	455	454	453	452	451	450	447	446	445	444	443	442	441	440	V40422
477	476	475	474	473	472	471	470	467	466	465	464	463	462	461	460	477	476	475	474	473	472	471	470	467	466	465	464	463	462	461	460	V40423

Standard Output (Y) Addresses

Reserved Memory Tables

MSB							LSB								Address	
17	16	15	14	13	12	11	10	7	6	5	4	3	2	1		0
017	016	015	014	013	012	011	010	007	006	005	004	003	002	001	000	V40500
037	036	035	034	033	032	031	030	027	026	025	024	023	022	021	020	V40501
057	056	055	054	053	052	051	050	047	046	045	044	043	042	041	040	V40502
077	076	075	074	073	072	071	070	067	066	065	064	063	062	061	060	V40503
117	116	115	114	113	112	111	110	107	106	105	104	103	102	101	100	V40504
137	136	135	134	133	132	131	130	127	126	125	124	123	122	121	120	V40505
157	156	155	154	153	152	151	150	147	146	145	144	143	142	141	140	V40506
177	176	175	174	173	172	171	170	167	166	165	164	163	162	161	160	V40507
217	216	215	214	213	212	211	210	207	206	205	204	203	202	201	200	V40510
237	236	235	234	233	232	231	230	227	226	225	224	223	222	221	220	V40511
257	256	255	254	253	252	251	250	247	246	245	244	243	242	241	240	V40512
277	276	275	274	273	272	271	270	267	266	265	264	263	262	261	260	V40513
317	316	315	314	313	312	311	310	307	306	305	304	303	302	301	300	V40514
337	336	335	334	333	332	331	330	327	326	325	324	323	322	321	320	V40515
357	356	355	354	353	352	351	350	347	346	345	344	343	342	341	340	V40516
377	376	375	374	373	372	371	370	367	366	365	364	363	362	361	360	V40517
417	416	415	414	413	412	411	410	407	406	405	404	403	402	401	400	V40520
437	436	435	434	433	432	431	430	427	426	425	424	423	422	421	420	V40521
457	456	455	454	453	452	451	450	447	446	445	444	443	442	441	440	V40522
477	476	475	474	473	472	471	470	467	466	465	464	463	462	461	460	V40523

Control Relay (C) Addresses

MSB								LSB								Address
17	16	15	14	13	12	11	10	7	6	5	4	3	2	1	0	
017	016	015	014	013	012	011	010	007	006	005	004	003	002	001	000	V40600
037	036	035	034	033	032	031	030	027	026	025	024	023	022	021	020	V40601
057	056	055	054	053	052	051	050	047	046	045	044	043	042	041	040	V40602
077	076	075	074	073	072	071	070	067	066	065	064	063	062	061	060	V40603
117	116	115	114	113	112	111	110	107	106	105	104	103	102	101	100	V40604
137	136	135	134	133	132	131	130	127	126	125	124	123	122	121	120	V40605
157	156	155	154	153	152	151	150	147	146	145	144	143	142	141	140	V40606
177	176	175	174	173	172	171	170	167	166	165	164	163	162	161	160	V40607
217	216	215	214	213	212	211	210	207	206	205	204	203	202	201	200	V40610
237	236	235	234	233	232	231	230	227	226	225	224	223	222	221	220	V40611
257	256	255	254	253	252	251	250	247	246	245	244	243	242	241	240	V40612
277	276	275	274	273	272	271	270	267	266	265	264	263	262	261	260	V40613
317	316	315	314	313	312	311	310	307	306	305	304	303	302	301	300	V40614
337	336	335	334	333	332	331	330	327	326	325	324	323	322	321	320	V40615
357	356	355	354	353	352	351	350	347	346	345	344	343	342	341	340	V40616
377	376	375	374	373	372	371	370	367	366	365	364	363	362	361	360	V40617
417	416	415	414	413	412	411	410	407	406	405	404	403	402	401	400	V40620
437	436	435	434	433	432	431	430	427	426	425	424	423	422	421	420	V40621
457	456	455	454	453	452	451	450	447	446	445	444	443	442	441	440	V40622
477	476	475	474	473	472	471	470	467	466	465	464	463	462	461	460	V40623
517	516	515	514	513	512	511	510	507	506	505	504	503	502	501	500	V40624
537	536	535	534	533	532	531	530	527	526	525	524	523	522	521	520	V40625
557	556	555	554	553	552	551	550	547	546	545	544	543	542	541	540	V40626
577	576	575	574	573	572	571	570	567	566	565	564	563	562	561	560	V40627
617	616	615	614	613	612	611	610	607	606	605	604	603	602	601	600	V40630
637	636	635	634	633	632	631	630	627	626	625	624	623	622	621	620	V40631
657	656	655	654	653	652	651	650	647	646	645	644	643	642	641	640	V40632
677	76	675	674	673	672	671	670	667	666	665	664	663	662	661	660	V40633
717	716	715	714	713	712	711	710	707	706	705	704	703	702	701	700	V40634
737	736	735	734	733	732	731	730	727	727	742	724	723	722	721	720	V40635

Appendix C

Determining I/O Update Time



C

Overview

Since the Remote Master and the CPU operate asynchronously from one another, it is possible that the remote I/O points may not be updated on every CPU scan. Therefore, in some applications it may be helpful to understand the amount of time required to update the remote I/O points. Depending on the number of I/O points used in your remote configuration and the baud rate you have selected for communication, your update time requirements will vary. This Appendix will show you how to estimate the total delay time for your system.

NOTE: In most situations, this delay will be so small that either it makes no difference to the particular application or the mechanical speeds of the field devices are slower than the delay itself.

If you have an application that requires a thorough understanding of the time delay, you can use the following information in order to calculate the delay:

- **Baud Rate** — this is the communication baud rate that you selected with the dipswitch settings on the remote master and remote slaves.
- **CPU Scan Time** — this is the total CPU scan time. The easiest way is to use AUX53 from a DL405 Handheld Programmer, or use the Diagnostics option under the PLC menu in our *DirectSOFT* Programming Software. This Use the respective specifications in the User's Manual. You can also use the DL405 User Manual to calculate the scan time, but this is often very time consuming. If you use the User Manual, you will have to estimate this time, because it is dependent on the main program length, and number of I/O points in the local and expansion bases as well.
- **Remote Master Scan** — this is the time required for the Remote Master to scan the individual Slave stations to update the status of the I/O modules. Use the formula and table shown on the following page.
- **Module ON to OFF, OFF to ON Response Time** — this is the amount of time that the module requires to see a transition in status. For example, when a switch connected to an input module closes, it can take a few milliseconds (1-12 typical) before the module actually makes the transition from OFF to ON. The easiest way to find this information is from the module specifications in the respective User Manuals. This basic information is also available in the specifications of the Sales Catalog.
- **Total Delay Time** — this is the total delay time that takes all of the above factors into consideration. There are several formulas that can be used to calculate this delay time. See the formulas on Page C5 of this Appendix. Once you have selected the formula applicable to your system, you will use the information you have gathered for the above items to calculate the total system delay time.

Since each application is different, we cannot possibly show all of the options for the CPU scan time or the possible module response delays. You can easily find this information in other publications. However, the next few pages *will* show you how to calculate the delay time for the Remote Master Scan. Also, we show the total delay time for our example system that was used earlier in this manual.

Remote I/O Update Table

The table shown below shows you how much time is required for the Remote Master Module to update its I/O data to its internal buffers. Remember from earlier reading in this chapter that the remote I/O scan and CPU scan are asynchronous. The CPU may be looking at the master module's internal buffers several times before the master actually has enough time to write new data there. This chart shows the maximum amount of delay based on the number of I/O points being used.

No. of Remote I/O Points	Update Time Required	
	19.2 kBaud	38.4 kBaud
16	3.64ms	1.82ms
32	5.72 ms	2.86 ms
64	9.88 ms	4.94 ms
128	18.20 ms	9.10 ms
160	22.36 ms	11.18 ms
192	26.52 ms	13.26 ms
224	30.68 ms	15.34 ms
256	34.84 ms	17.42 ms
288	39.00 ms	19.50 ms
320	43.16 ms	21.58 ms
352	47.32 ms	23.66 ms
384	51.48 ms	25.74 ms
416	55.64 ms	27.82 ms
448	59.80 ms	29.90 ms
480	63.96 ms	31.98 ms
512	68.12 ms	34.06 ms

Determining I/O Update

Remote Scan Time Formula

You can figure out the amount of time required for the remote I/O scan update with the following formula:

$$T_{RS} = \text{Time from Above Table} + (2 \text{ ms} \times \text{No. of Slaves})$$

Example: Given a 38.4 kB system with a total of 128 remote points and 3 slaves.

$$T_{RS} = 9.10 \text{ ms} + (2 \text{ ms} \times 3) = 15.10 \text{ ms}$$

Calculating Total Delay for the System

Now that you have calculated the time required for the Remote Master to go through its scan cycle and update its internal buffer area, we need to add this time to other delay times inherent in the overall system. Below is an example where a remote input changes a remote output.

Example Where A Remote Input Changes a Remote Output

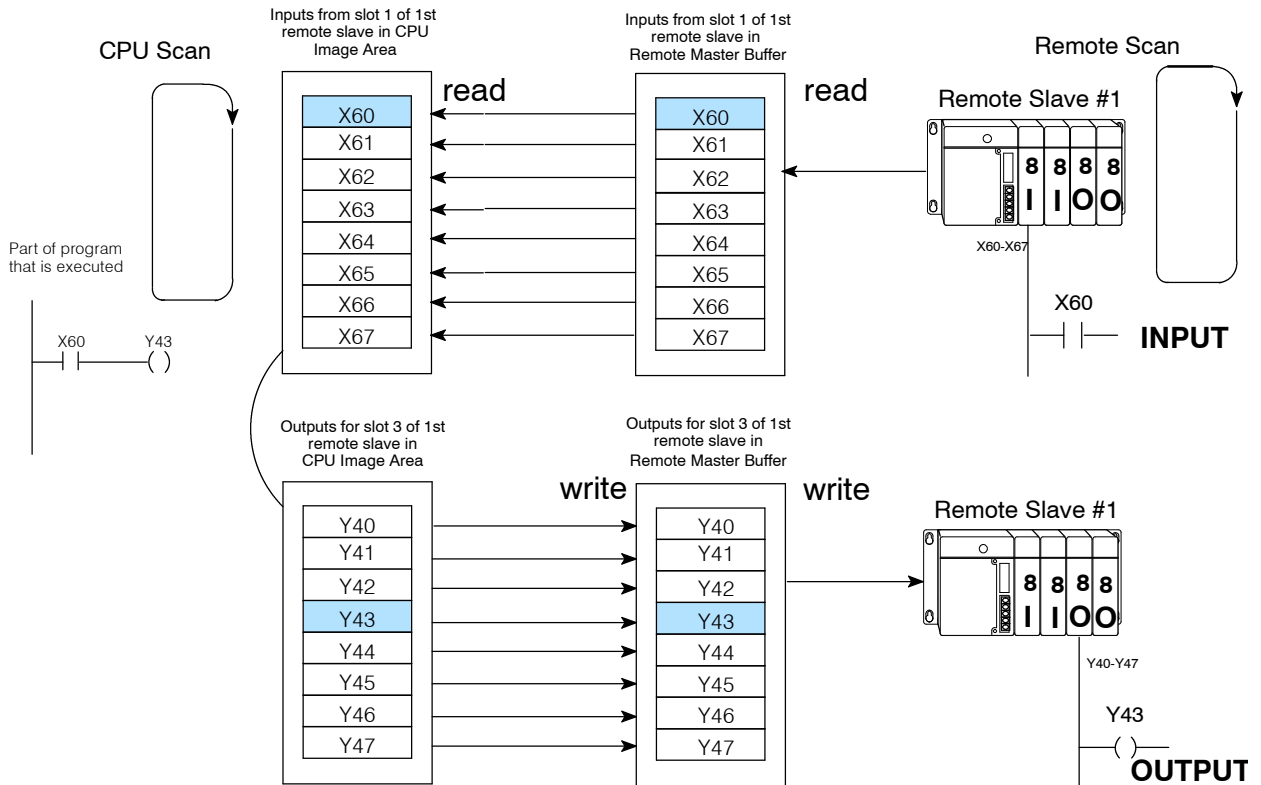

The above drawing could be simplified schematically to look like this:

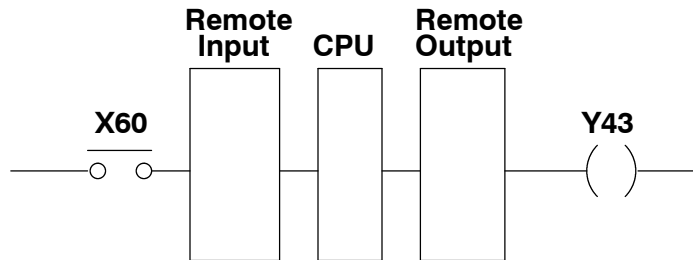

The table on the adjacent page gives you a table that shows the formula for calculating the overall system delay for this scenario. It also shows you formulae for two other possible scenarios.

Total Delay Time Formulas

The following table provides delay formulas for three different configuration scenarios. Notice that there are two sets of formulas for each scenario. The formula chosen depends on whether the CPU scan time is greater than or less than the Remote Master scan time. There are several variables used in the formulas. The following descriptions will help you understand them.

- **T_{CS}** — CPU scan time. You can use DirectSOFT or a Handheld Programmer to determine this time, or you can estimate the time required by using the DL405 User Manual.
- **T_{RS}** — Remote Master scan time. Use the table and formula shown previously to determine this time.
- **T_{IN}** and **T_{OUT}** — Module response delay time. You can find this information from the module specifications tables which are usually found in the DL405 User Manual.

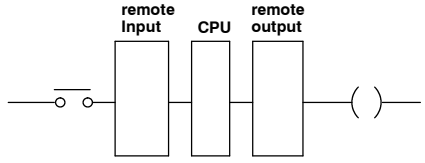
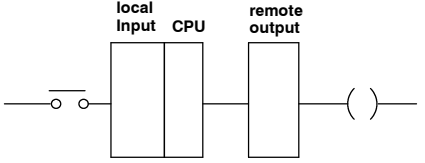
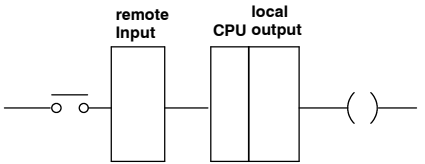
	T_{RS} T_{CS}	T_{RS} T_{CS}
<p>Remote Input to Remote Output</p> 	$T_{IN} + 6(T_{CS}) + T_{OUT}$	$T_{IN} + 4(T_{RS}) + 6(T_{CS}) + T_{OUT}$
<p>Local Input to Remote Output</p> 	$T_{IN} + 4(T_{CS}) + T_{OUT}$	$T_{IN} + 2(T_{RS}) + 4(T_{CS}) + T_{OUT}$
<p>Remote Input to Local Output</p> 	$T_{IN} + 4(T_{CS}) + T_{OUT}$	$T_{IN} + 2(T_{RS}) + 4(T_{CS}) + T_{OUT}$

The following page will show you how to use one of the formulas to calculate the delay time for our example system.

Delay Time Example

The following example shows you how to calculate the total time it takes for a remote input to be read and later updated by the CPU scan; and then, a remote output taking place at the remote base. We have used the same configuration as shown throughout this text which features 3 remote slaves, 1 master and 128 remote I/O points, communicating at 38.4 kBaud.

EXAMPLE:

38.4 kBaud, D4-440, X60 causing a response by Y43.

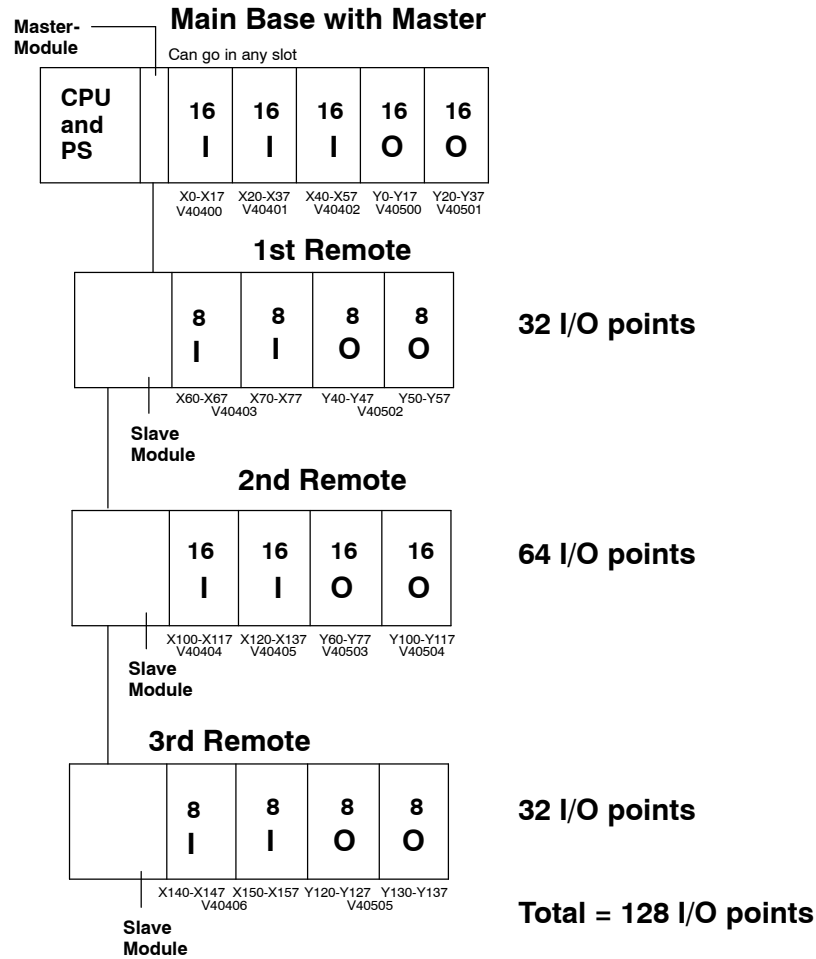

Given that CPU scan (T_{CS}) is estimated to be 50 ms.

T_{IN} = Maximum response input module time (08ND3S) = 12 ms

T_{OUT} = Maximum response output module time (08TD1) = 1 ms

$T_{RS} = 9.10 \text{ ms} + (2\text{ms} \times 3) = 15.10 \text{ ms}$ T_{CS}

Total Delay for Configuration = $T_{IN} + 6(T_{CS}) + T_{OUT}$

= 12 ms + 6(50 ms) + 1 ms

= 313 ms