

**SYSMAC
C200H-NC211**

Position Control Unit

OPERATION MANUAL

OMRON

C200H-NC211 Position Control Unit

Operation Manual

Revised February 2003

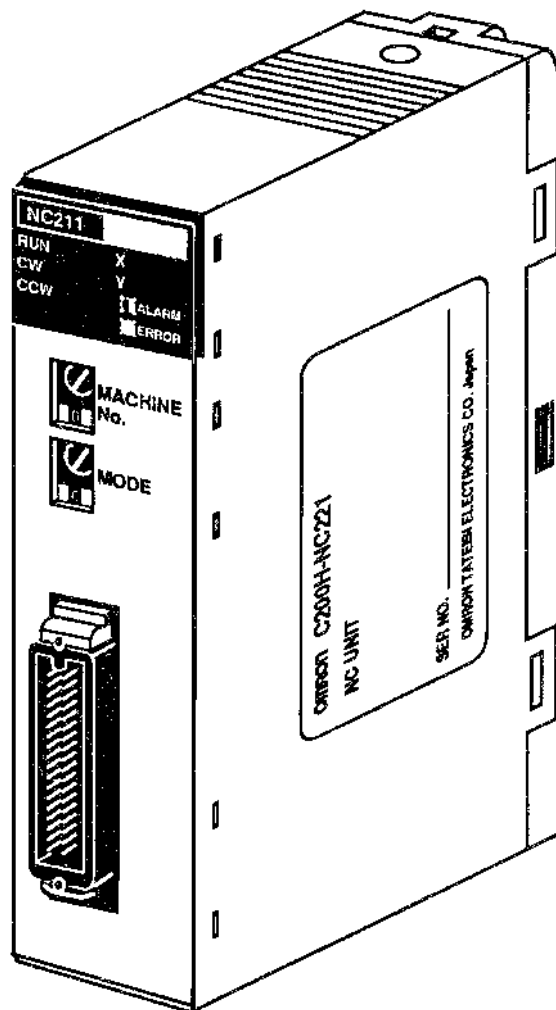



Notice:

OMRON products are manufactured for use according to proper procedures by a qualified operator and only for the purposes described in this manual.

The following conventions are used to indicate and classify precautions in this manual. Always heed the information provided with them. Failure to heed precautions can result in injury to people or damage to the product.

 **DANGER** Indicates information that, if not heeded, is likely to result in loss of life or serious injury.

 **WARNING** Indicates information that, if not heeded, could possibly result in loss of life or serious injury.

 **Caution** Indicates information that, if not heeded, could result in relatively serious or minor injury, damage to the product, or faulty operation.

OMRON Product References

All OMRON products are capitalized in this manual. The word “Unit” is also capitalized when it refers to an OMRON product, regardless of whether or not it appears in the proper name of the product.

The abbreviation “Ch,” which appears in some displays and on some OMRON products, often means “word” and is abbreviated “Wd” in documentation in this sense.

The abbreviation “PC” means Programmable Controller and is not used as an abbreviation for anything else.

Visual Aids

The following headings appear in the left column of the manual to help you locate different types of information.

Note Indicates information of particular interest for efficient and convenient operation of the product.

1, 2, 3... 1. Indicates lists of one sort or another, such as procedures, checklists, etc.

© OMRON, 1990

All rights reserved. No part of this publication may be reproduced, stored in a retrieval system, or transmitted, in any form, or by any means, mechanical, electronic, photocopying, recording, or otherwise, without the prior written permission of OMRON.

No patent liability is assumed with respect to the use of the information contained herein. Moreover, because OMRON is constantly striving to improve its high-quality products, the information contained in this manual is subject to change without notice. Every precaution has been taken in the preparation of this manual. Nevertheless, OMRON assumes no responsibility for errors or omissions. Neither is any liability assumed for damages resulting from the use of the information contained in this publication.

TABLE OF CONTENTS

SECTION 1

Introduction	1
1-1 Features	2
1-2 Model Differences	3
1-3 System Configuration	6
1-4 Components	9
1-5 Control System Principles	11
1-6 Programming Precautions	16

SECTION 2

Before Operation	17
2-1 Operational Flow	18
2-2 Switch Settings	20
2-3 Switch Settings Examples	24
2-4 Wiring	33
2-5 Dimensions	48

SECTION 3

Operation	49
3-1 Wiring Data	50
3-2 Data Configuration and Allocation	52
3-3 DM Area Allocation	54

SECTION 4

Commands	67
4-1 Setting Up Data Memories	68
4-2 Unit Table Creation	95

SECTION 5

IR Area Allocation	97
5-1 IR Area Allocation	98
5-2 IR Area Data Format	100
5-3 IR Area Settings	105
5-4 Execution Examples	106
5-5 ORIGIN SEARCH Completion Examples	119
5-6 Start/Stop	122

SECTION 6

Manual Operations	125
6-1 IR Area Settings	126
6-2 HIGH-SPEED JOG	127
6-3 LOW-SPEED JOG	128
6-4 INCH	129
6-5 RESET ORIGIN	130
6-6 External Interrupt Commands	131
6-7 STOP	134
6-8 CHANGE SPEED	146
6-9 CHANGE SPEED COEFFICIENT	147

TABLE OF CONTENTS

SECTION 7	
The TEACH Command	151
7-1 IR Area Settings	153
7-2 Execution Example	155
7-3 Teaching from the Programming Console	156
7-4 TRANSFER DATA	158
7-5 Present Position Preset	165
SECTION 8	
Error Processing	169
8-1 Alarms and Errors	170
8-2 Alarm/Error Indicators	172
8-3 RELEASE PROHIBIT	173
8-4 READ ERROR	176
8-5 Troubleshooting from the PC	179
8-6 Detection of Abnormal Pulse Outputs	181
8-7 Alarm Code List	183
8-8 Error Code List	185
SECTION 9	
Programming Examples	189
9-1 Example 1	190
9-2 Example 2	196
9-3 Example 3	199
9-4 Example 4	201
9-5 Example 5	203
9-6 Example 6	208
9-7 Example 7	210
9-8 Example 8	218
9-9 Example 9	219
9-10 Example 10	221
9-11 Example 11	229
Appendices	
A Application in CS1-series PCs	233
B Specifications	241
C Standard Models	245
Glossary	247
Index	251
Revision History	255

About this Manual:

This manual describes the operation of the NC211-C200H Programmable Control Unit (PCU). The PCU is a special I/O device that receives positioning commands, either externally or from a PC, and uses that data to control the operation of a stepping motor or servomotor driver.

Section 1 provides an introduction to the features and possible system configurations of the PCU. It also explains the differences between the NC211-C200H and the older NC112-C200H PCU.

Section 2 contains information on how to prepare the PCU for operation, including switch setting and wiring information.

Section 3 presents data configuration and allocation information.

Section 4 presents and explains the operation of PCU commands.

Section 5 presents the IR area data format and execution examples illustrating different configurations.

Section 6 explains the Manual operation commands of the PCU.

Section 7 explains the TEACH command and presents several examples.

Section 8 explains Error Processing.

Section 9 presents 11 programming examples which pull together all of the material in this manual.



WARNING

Failure to read and understand the information provided in this manual may result in personal injury or death, damage to the product, or product failure. Please read each section in its entirety and be sure you understand the information provided in the section and related sections before attempting any of the procedures or operations given.

SECTION 1

Introduction

1-1	Features	2
1-2	Model Differences	3
1-3	System Configuration	6
1-4	Components	9
1-5	Control System Principles	11
1-5-1	Open-Loop System	13
1-5-2	Semiclosed-loop System	15
1-6	Programming Precautions	16

Section Overview

The C200H-NC211 Position Control Unit is a Special I/O Unit that receives positioning commands, either externally or from a Programmable Controller (PC), and uses that data to output control pulses to a stepping motor driver or a servomotor driver.

This section describes the basic features and components of the Position Control Unit, as well as the basic configuration and operating principles of positioning control systems. Be sure to read and study these sections carefully; an understanding of the control system is essential for successful operation.

1-1 Features

Applicable Motor Drivers

The pulse train output can be easily connected to either of the following devices:

- 1, 2, 3...**
1. Stepping motor driver
 2. Servomotor driver designed for pulse train input

Number of Control Axes and Controlling Capacity

This Unit is distinguished by having two control axes. It is capable of controlling two axes simultaneously (linear interpolation) and controlling each axis independently. It controls speeds and positions through parameters recorded in the DM (Data Memory) Area of the C200H PC.

Compact Size

The Unit is the same size as other Special I/O Units, but its greater capacity makes for increased space efficiency and easier multi-axial control.

Data Transfer

Positioning actions, speeds, and speed changes contained in the DM area or other areas of the PC can be quickly transferred via a TRANSFER DATA command, even during positioning. More flexible control is now possible.

Upward Compatibility

To ensure compatibility with single-axis Position Control units, this Unit has commands and status allocations similar to the C200H-NC112.

1-2 Model Differences

The C200H-NC211 incorporates the following additional functions and improvements over the C200H-NC112.

Two Control Axes

There are now two control axes, making linear interpolation possible. Of course each axis can also be operated independently.

Increased Positioning Data Capacity

The positioning data capacity of each axis has been increased from 20 to 53. When more than 20 positioning actions are needed, back-panel DIP switch pins No. 7-9 can be set to expand the usable DM area (in 200-word segments from DM 0100 to 0999).

Improved Data Transfer Performance

Speed and position data can be transferred even during positioning.

Improved Speed Change Performance

The speed coefficient can now be used to change speed even during positioning.

Increased Capacity

Two axes provide the word and data memory capacity of two Special I/O Units. The machine number which immediately follows the assigned machine number cannot be set to the other unit.

Item	C200H-NC112	C200H-NC211
Available words	n to n+9	n to n+19
Data Memory	m to m+99	m to m+199

Additional DM Area Functions

The origin and origin proximity signal settings are no longer made with the back-panel switch. Instead, they are now set in the following DM words.

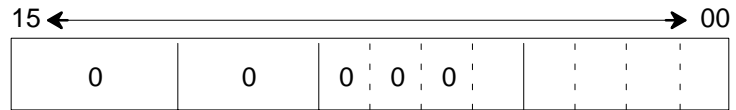



(X) DM word m+21
 (Y) DM word m+121

bit	Designation	1	0
00	ORIGIN SEARCH direction	CCW	CW
01	Origin proximity signal presence	present	absent
02	Origin proximity type	N.O.	N.C.
03	Origin signal type	N.O.	N.C.
04	ORIGIN SEARCH method	present	absent

N.O: Normally-open contacts
 N.C: Normally-closed contacts

Additional IR Area Functions

Word		Bit	Function
X-axis	Y-axis		
n+1	n+6	07	CHANGE SPEED COEFFICIENT 
		15	Transfer buffer 

Additional Codes for Target Position Data

The following code types have been added to distinguish between single-axis target positioning data and interpolation data.

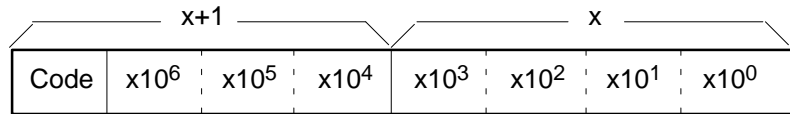

↓

0	CW	Absolute value	Single-axis end point
1	CCW		
2	CW	Incremental value	
3	CCW		
4	CW	Absolute value	Interpolation end point
5	CCW		
6	CW	Incremental value	
7	CCW		

1-3 System Configuration

The basic configurations are shown below and on the next page. Unit outputs are connected to a motor driver, for either a stepping motor or servomotor that can receive pulse train inputs. The Unit is controlled by inputs from devices and/or a control panel. It, in turn, outputs pulse trains and direction signals to control the motor driver. The motor driver controls either a stepping motor or a servomotor, which in turn controls a positioning device (such as a feed screw). Some configurations also require an Input Unit on the C200H PC to control the motor driver.

Stepping Motor Driver Connection

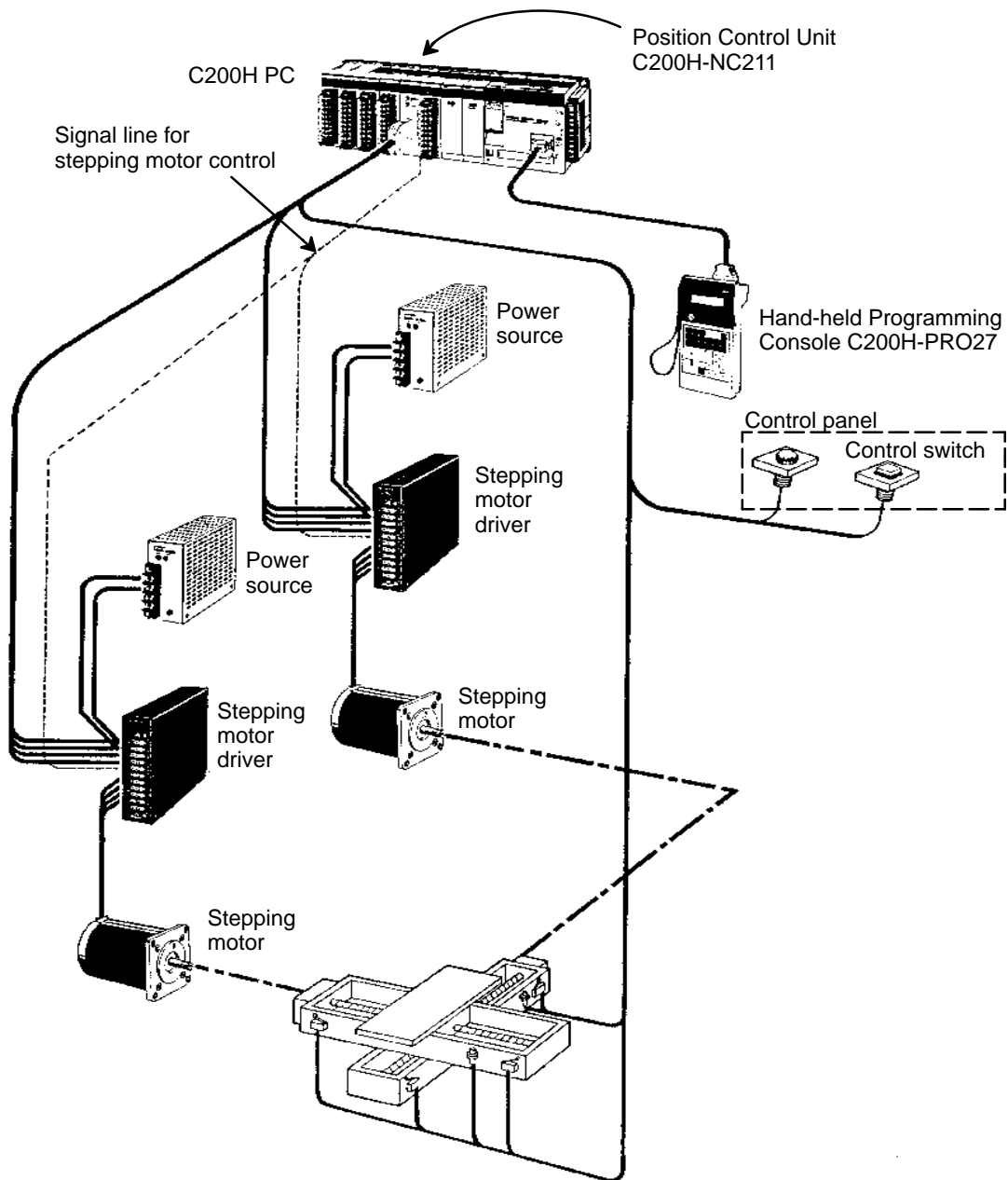

Servomotor Driver Connection

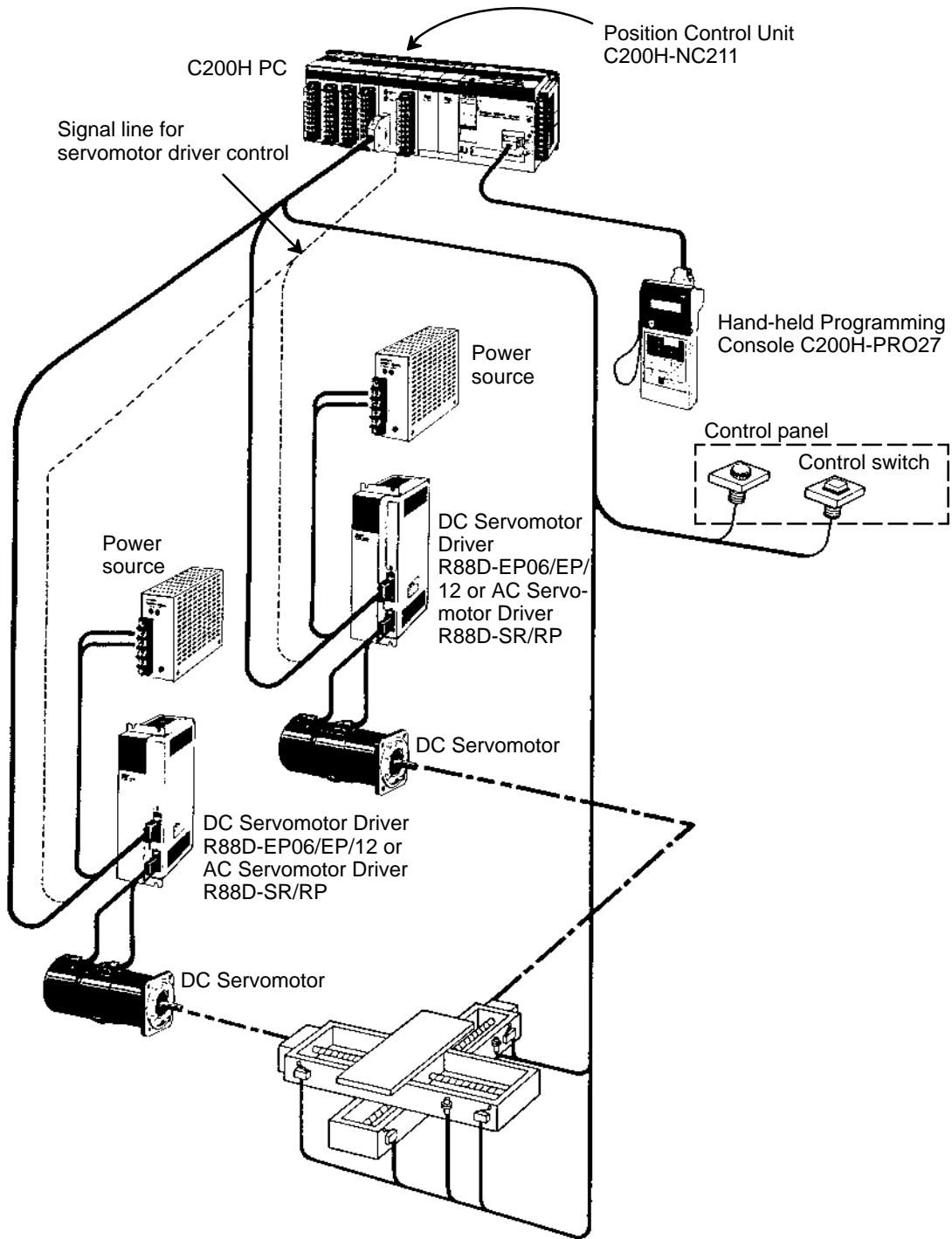

Maximum Number of Special I/O Units per PC

The 200H-NC211 Position Control Unit differs from other Special I/O Units in that it occupies twice the usual IR and DM area. Normally, a maximum of 10 Special I/O Units, including Position Control Units, High-Speed Counters, etc., can be mounted to the same PC. The NC211, however, counts as two Units, so a maximum of only five 200H-NC211 Units can be connected per PC.

Also be aware that it is possible to connect a combination of Units that require more power than can be provided by the available power supply. For a specific configuration, refer to specifications in the appropriate hardware manuals.

Mounting Location

The Position Control Unit can be mounted to any but the 2 rightmost CPU Rack slots. Mounting the Unit to either of these slots will prevent you from mounting peripheral devices directly to the PC's CPU. When mounting to an Expansion I/O Rack or Remote Slave I/O rack, however, any slot may be used.

In addition to this, for remote I/O devices there are limitations, as described below, due to data transfer capacities.

Number of Special I/O Units Connectable to Remote I/O

Please note the following limitations on the number of Special I/O Units which can be connected to Remote I/O Slave Racks.

The numbers given in the following table assume that no other devices are being used, and represent the maximum number of Special I/O Units that can be used on a Remote I/O Slave Rack when the Units are all from group A, B, C or D.

A	B	C	D
Number of High-speed Counter, Position Control (NC111/NC112), ASCII or Analog Input Units.	Number of Multi-point I/O Units.	Number of Temperature Sensor Units.	Number of Position Control Units (NC211).
Total of 4 Units	Total of 8 Units	Total of 6 Units	Total of 2 Units

A combination of Units from different groups must satisfy both of the following equations:

$$3A + B + 2C + 6D \leq 12$$

$$A + B + C + D \leq 8$$

1-4 Components

In addition to the front-panel components described below, there is a DIP switch located on the back panel. Pin settings for this switch, which are described in Section 2-2 Switch Settings, determine certain aspects of control system operation.

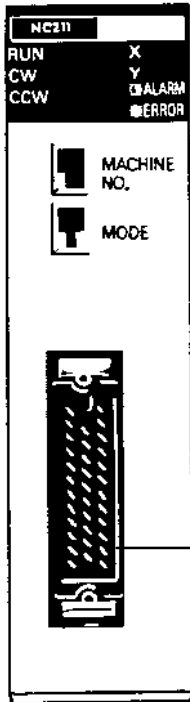

Indicators

RUN: indicates operation is in progress	X: indicates X-axis operation/buffer transfer Y: indicates Y-axis operation/buffer transfer
CW: indicates controlled system (motor) is revolving clockwise	ALARM: blinks when an abnormality has occurred
CCW: indicates controlled system (motor) is revolving counterclockwise	ERROR: lights when an error has occurred

Setting switches*

MACHINE No.	Allocates a unit number (0 to 8) to the Position Control Unit
MODE	Selects an operating mode (0 to 3).

Connector

Used to connect the Position Control Unit to a stepping motor driver or servomotor driver.

Attach the enclosed connector to the proper cable.

* Before operating these switches, make sure that power to the PC is off.

When setting the switches, use a screwdriver if necessary, but do not apply excessive force.

Do not leave the switches halfway between two setting points or the Position Control Unit may malfunction.

Indicators

Indicator	Color	Function
RUN	Green	Lit during normal operation. Goes out for errors.
CW	Green	Lit during output of CW (clockwise) pulses.
CCW	Green	Lit during output of CCW (counterclockwise) pulses.
X	Green	Lit during positioning of X-axis positioning, or when data is being transferred from buffer to memory.
Y	Green	Lit during positioning of Y-axis, or when data is being transferred from buffer to memory.
ALARM (flashing)	Red	Flashing when a BCD error exists in initial data, speed data, or positioning data updated with TRANSFER DATA.
ERROR	Red	Lit when an error has occurred causing operation to stop.

Since the C200H-NC211, in contrast to other Special I/O Units, occupies the space of two units, do not set other units to the machine number which immediately follows the machine number of the C200H-NC211.

The ALARM LED flashes when data for X and Y within the assigned range is not entered in the respective DM areas for the X and Y axes.

When only one axis is used, short-circuit the CW limit and CCW limit of the unused axis to 0 V in the input power supply. The ERROR LED will light if these are not short-circuited, but the axis in use will operate normally.

1-5 Control System Principles

Control systems can be quite simple or relatively complex. The most basic case is an open-loop system, in which a particular operation is carried out according to programmed instructions, but in which feedback is not provided for automatic adjustment. The C200H-NC211 Position Control Unit can be used in an open-loop system in conjunction with a stepping motor.

In a closed-loop system, on the other hand, the PC controls an external process without human intervention. The servomotor provides direct feedback so that actual values (of positions, speeds, and so on) are continuously adjusted to bring them more closely in line with target values. In some systems, the digital feedback signals are transmitted to a digital-to-analog converter to complete the feedback loop, allowing automated control of the process.

A semiclosed-loop system is similar to a closed-loop system, except that feedback is provided by a tachogenerator and a rotary encoder rather than directly by the servomotor. If the C200H-NC211 Position Control Unit is used with a servomotor, the servomotor driver must be able to handle digital signals, and there is no need for a D/A converter. In addition, the servomotor is connected to a tachogenerator and a rotary encoder. The Unit can thus be used in either an open-loop or a semiclosed-loop system.

Both open-loop and semiclosed-loop systems are described in more detail on the following pages.

Data Flow

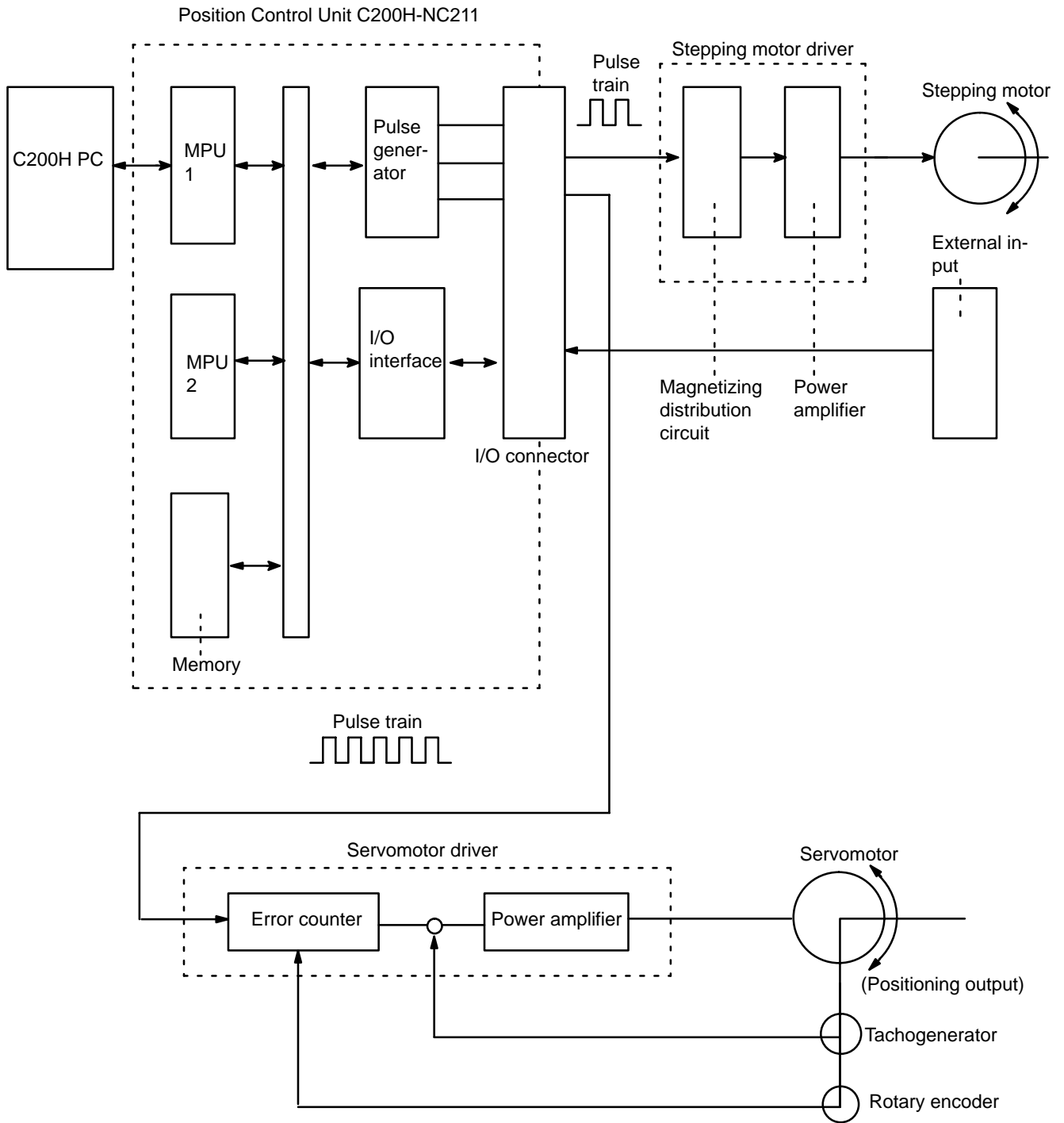

1-5-1 Open-Loop System

In an open-loop system, the Position Control Unit outputs pulse trains as specified by the PC program to control the angle of rotation of the motor. Because the Unit outputs pulse trains, it is generally used with a stepping motor. The angle of rotation of a stepping motor can be controlled through the number of pulse signals supplied to the motor driver. The number of rotations of the stepping motor is proportional to the number of pulses supplied by the Unit, and the rotational speed of the stepping motor is proportional to the frequency of the pulse train.

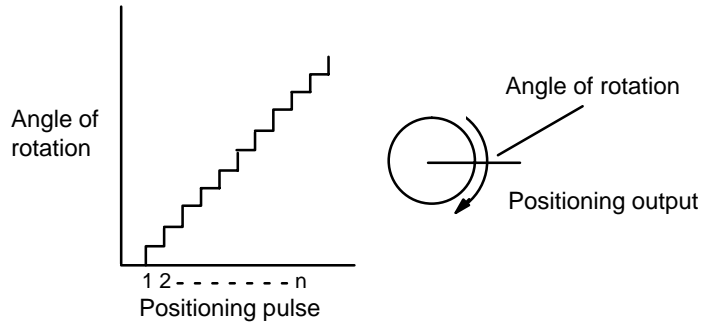

Simplified Positioning System

The following diagram and parameters illustrate a simplified positioning system.

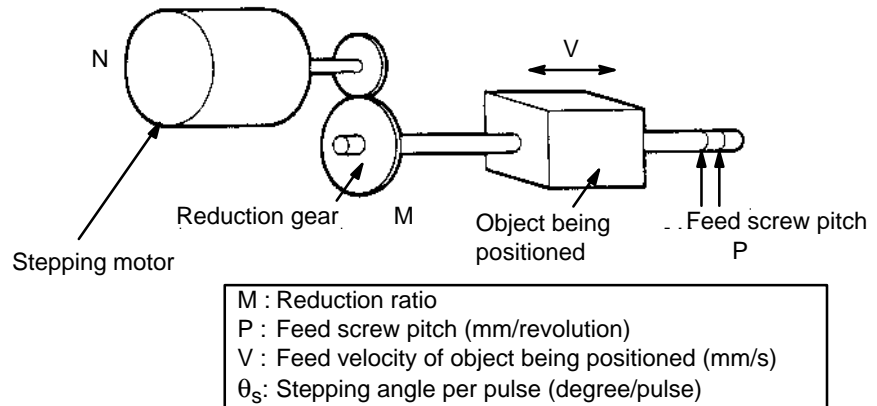

The positioning accuracy in mm/pulse is computed as follows:

$$\begin{aligned} \text{Positioning accuracy} &= P / (\text{pulses per revolution} \times M) \\ &= P / ((360 / \theta_s) \times M) \\ &= (P \times \theta_s) / (360 \times M) \end{aligned}$$

The required pulse frequency from the Unit (pulses/second) is computed as follows:

$$\begin{aligned} \text{Pulse frequency} &= V / \text{Positioning accuracy} \\ &= (360 \times M \times V) / (P \times \theta_s) \end{aligned}$$

And the required number of pulses to feed an object by a distance L in mm is computed as follows:

$$\begin{aligned} \text{Number of pulses} &= L / \text{Positioning accuracy} \\ &= (360 \times M \times L) / (P \times \theta_s) \end{aligned}$$

1-5-2 Semiclosed-loop System

When the Position Control Unit is used in a semiclosed-loop system, the system supplies feedback to compensate for any discrepancy between target values and actual values in position or speed. This system detects motor rotation amounts, for example, computes the error between the target value and actual movement value, and zeroes the error through feedback. The diagram below illustrates the basic configuration of a semiclosed-loop system.

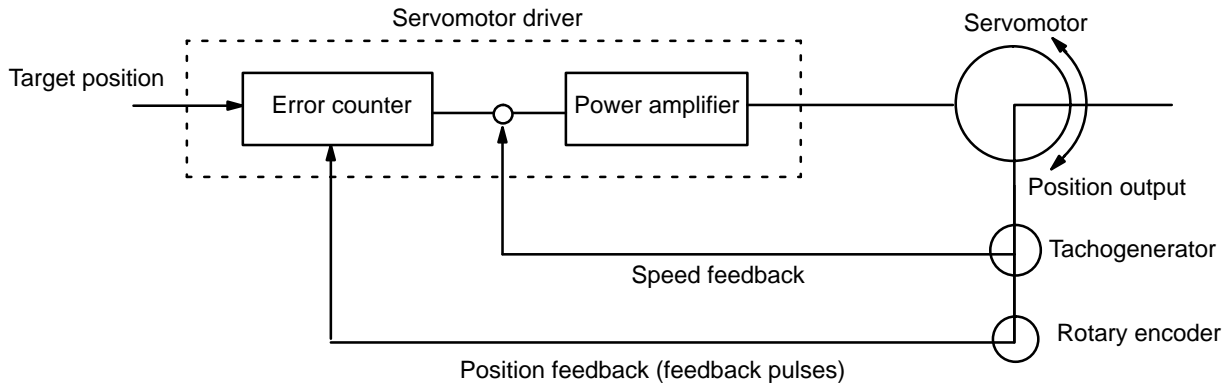

- 1, 2, 3...**
1. First, the target position is transmitted to the error counter in units of encoder pulses. The servomotor driver must be able to handle digital input.
 2. The motor rotates at a speed corresponding to the speed voltage. The rotary encoder connected to the motor axis rotates in sync with the motor, generates feedback pulses, and subtracts error counter contents.
 3. Consequently, the encoder rotation is equivalent to the target position, and the motor stops rotating when the error counter count and the speed voltage become zero.
 4. While the motor is stopped, the rotary encoder constantly maintains the stopped position through correction. In the event that the motor axis slightly moves, the error counter receives a feedback pulse from the rotary encoder, whereby a rotation voltage is emitted in the reverse direction from which the rotary encoder moved, causing the motor to rotate toward its original position. This operation is called servolock or servoclamp.
 5. In order to execute positioning with acceleration and deceleration, target positions are set consecutively in the error counter for processing.
 6. The target position becomes the count for the error counter and controls the motor by conversion to a speed voltage for the servomotor driver. The position thus equals the total count of target positions and the speed will depend on the target position per unit time.

1-6 Programming Precautions

Starting Simultaneous Single-axis Operation of the X and Y Axes

When the X and Y axes are started simultaneously as independent axes, the X axis will be started first and the Y-axis startup will be delayed by 10 to 50 ms while internal startup processing is being performed. When interpolation operation is used, both axes start simultaneously.

Timing Restrictions for the START Command

If a START command is sent while the axis is decelerating to a stop, the START command will not be executed. In particular, an Interpolation START command will not be executed (it will be ignored) if either the X axis or Y axis is decelerating to a stop.

I/O Refresh Instruction (IORF(97))

Thoroughly read and understand the functions of IORF(97) before executing this instruction. If IORF(97) is used incorrectly, the proper commands may not be sent to the Position Control Unit, resulting in incorrect operation.

For example if IORF(97) is executed after a START command is sent to the Position Control Unit from an interrupt subroutine and regular cyclic refreshing is disabled, the OFF transition in the START command bit will not be recognized, preventing the Unit from starting operation.

SECTION 2 Before Operation

2-1	Operational Flow	18
2-2	Switch Settings	20
2-3	Switch Settings Examples	24
2-4	Wiring	33
2-4-1	Output Connection Examples	40
2-4-2	Input Connection Examples	44
2-4-3	Wiring Precautions	47
2-5	Dimensions	48

Section Overview

Before the Position Control Unit can be operated, switch settings and wiring must be correct. This section presents the settings and functions of switches, provides examples of and precautions for wiring, and gives dimensions of Units both when mounted and unmounted. Be sure that all settings and wiring match your positioning system specifications.

2-1 Operational Flow

The basic procedure used to initially operate the Unit is outlined below. Refer to applicable sections of the manual for details on each of these steps.

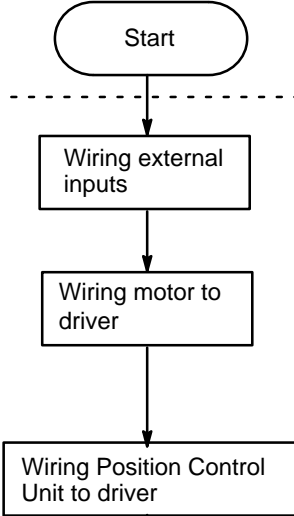
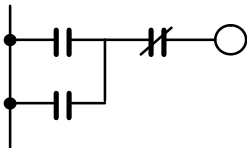
Item	Procedure	Refer to:
Wiring	 <p>Origin, origin proximity, CW/CCW limits, emergency stop, external interrupt</p> <p>Follow motor and driver and instruction manuals for wiring details</p>	2-4 Wiring
	<p>Setting back-panel DIP switch</p> <ul style="list-style-type: none"> • Output pulse selection • External interrupt selection • External interrupt response • Allocation for DM area for position data expansion 	2-2 Switch Settings
	<p>Data setting</p> <ul style="list-style-type: none"> • DM area (key input via Programming Console) • Parameters; Positioning actions • Speeds; Origin search direction • Origin proximity signal type • Presence of origin proximity signal • Origin signal type • Origin search method 	Section 4 Commands
	<p>Writing PC program</p> <p>Programming IR area (key input via Programming Console)</p> 	Section 9 Programming Examples

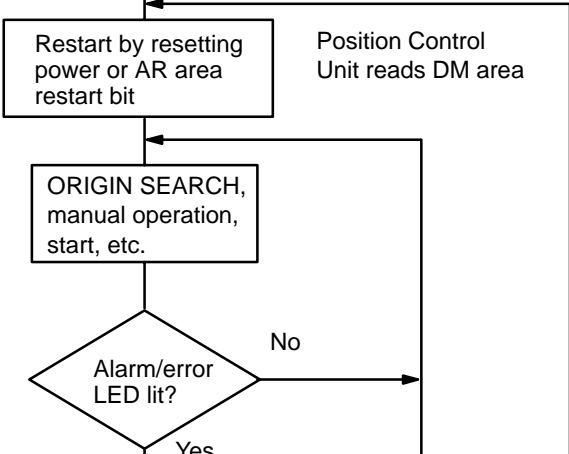
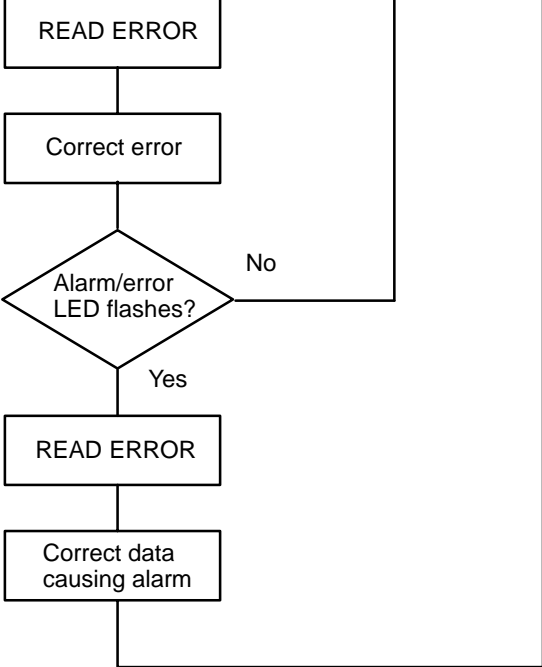
Item	Procedure	Refer to:
Trial run	 <pre> graph TD Start([Restart by resetting power or AR area restart bit]) --> Search[ORIGIN SEARCH, manual operation, start, etc.] Search --> Lit{Alarm/error LED lit?} Lit -- No --> Read[Position Control Unit reads DM area] Read --> Search Lit -- Yes --> ErrorExists[Error exists] </pre>	<p>8-5 Troubleshooting From the PC</p> <p>AR area error and restart bits for Special I/O Units</p>
Error processing	 <pre> graph TD ErrorExists[Error exists] --> ReadError1[READ ERROR] ReadError1 --> Correct1[Correct error] Correct1 --> Flashes{Alarm/error LED flashes?} Flashes -- No --> Read[Position Control Unit reads DM area] Read --> Search[ORIGIN SEARCH, manual operation, start, etc.] Flashes -- Yes --> ReadError2[READ ERROR] ReadError2 --> Correct2[Correct data causing alarm] Correct2 --> Search </pre>	<p>8-4 READ ERROR</p> <p>Section 8 Error Processing</p>

2-2 Switch Settings

Always turn off PC power before setting the unit number switch. Use a regular screwdriver, being careful not to damage the slot in the screw. Be sure not to leave the switch midway between settings.

Unit Number Switch ("MACHINE NO. ")

This switch is labeled "MACHINE NO." on the front panel, but its setting affects what is called the unit number throughout this manual.

Switch	Function
Unit number ("Machine No.")	Used to set the unit number (between 0 and 8). Do not set the same number for more than one Unit. Doing so will cause an error and prevent operation.
Mode	Used to set the mode from 0 to 3.

Mode Switch

This switch sets one of operation modes 0 to 3. Select an appropriate operation mode in accordance with the motor driver or signal lines to be used.

Since the C200H-NC211 occupies as much internal space as two Units, another Unit cannot be assigned the unit number that immediately follows the C200H-NC211's unit number. If this is done, a setting error will result and the unit will not operate.

0

This mode is used to control a stepping motor driver. In this mode, connect a sensor to the origin signal lines (Connectors No. 10, 11, 32, 33). The response time of the origin signal is 1 ms.

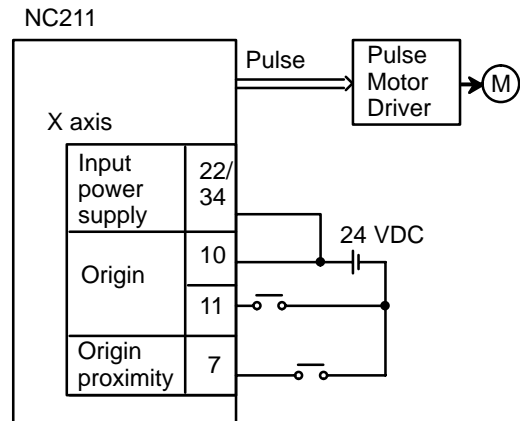

1

This mode is used to control a servomotor driver. The origin line driver input signals lines and deviation counter reset output signal lines are connected, but the positioning completed signal lines are not used. The response time of the origin line driver input is 0.1 ms.

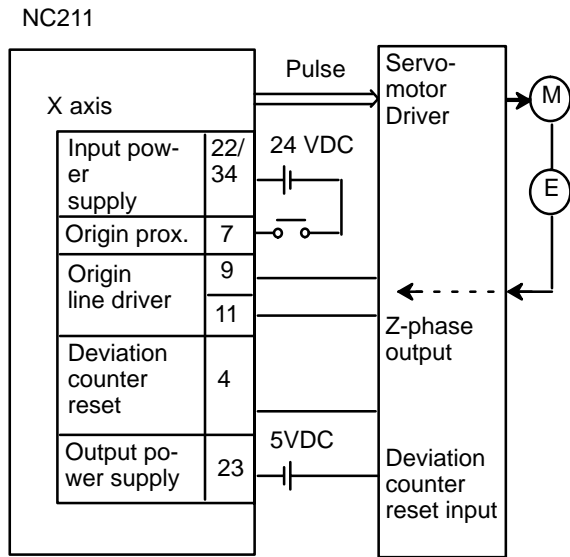

2

This mode is used with a servomotor driver. It is the same as mode 1, but uses the positioning completed signal lines.

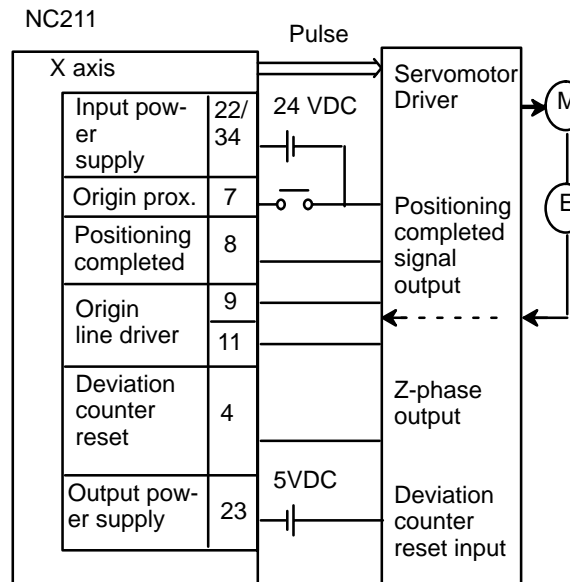

3

This mode is used with a servomotor driver when using an origin adjustment command.

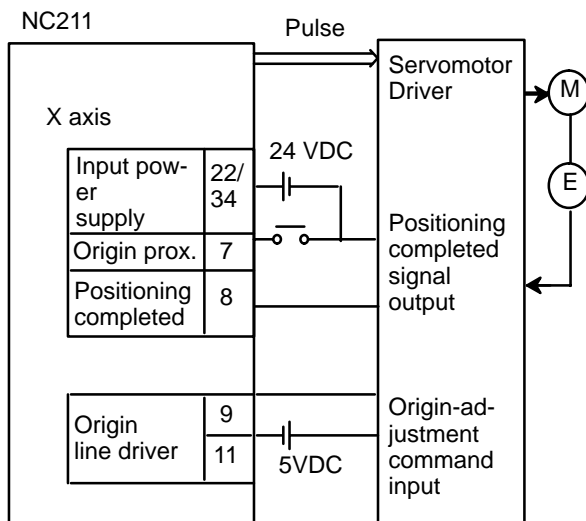

- Note**
- The above wiring diagrams for modes 1, 2, and 3 are applicable when an OMRON R88D Servomotor Driver is used.
Adjust the servomotor driver so that its positioning complete signal turns OFF while the motor is operating and ON when the motor stops.
 - The “No proximity signal” setting (bit 01 OFF) is effective only in mode 0.
In modes 1, 2, and 3, the Unit will operate with the proximity signal even if the axis is set to “No proximity signal.”

Functions of the Back-Panel DIP Switch

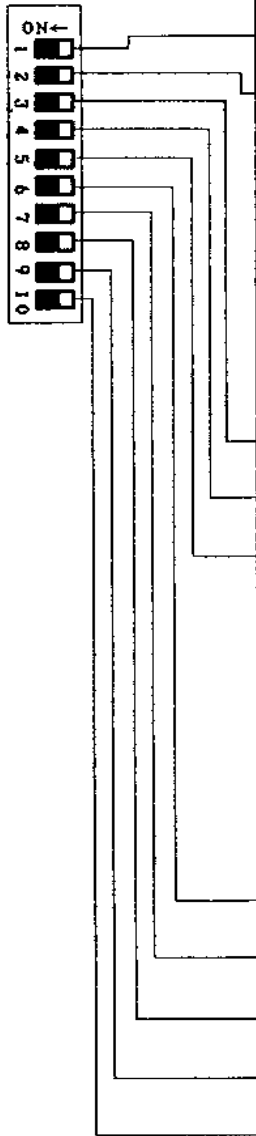

Pin No.	Switch designation	ON	OFF	Axis			
1	Output pulse selection	Pulse/direction output	CW/CCW output	X			
2	External interrupt selection	Determined by	Variable				
			Bit 06 of word n				
			<table border="1"> <tr> <td>0</td> <td>1</td> </tr> <tr> <td>External interrupt signal input causes deceleration and STOP</td> <td>External interrupt signal input causes CHANGE SPEED</td> </tr> </table>		0	1	External interrupt signal input causes deceleration and STOP
0	1						
External interrupt signal input causes deceleration and STOP	External interrupt signal input causes CHANGE SPEED						
3	External interrupt response	CHANGE SPEED	Deceleration STOP	Y			
4	Output pulse selection	Pulse/direction output	CW/CCW output				
5	External interrupt selection	Determined by	Variable				
			Bit 06 of word n+5				
			<table border="1"> <tr> <td>0</td> <td>1</td> </tr> <tr> <td>External interrupt signal input causes deceleration and STOP</td> <td>External interrupt signal input causes CHANGE SPEED</td> </tr> </table>	0	1	External interrupt signal input causes deceleration and STOP	External interrupt signal input causes CHANGE SPEED
0	1						
External interrupt signal input causes deceleration and STOP	External interrupt signal input causes CHANGE SPEED						
6	External interrupt response	CHANGE SPEED	Deceleration STOP	X/Y			
7	Allocation of DM area for position data expansion	$x2^0$	0-7 Setting. See table below.				
8		$x2^1$					
9		$x2^2$					
10	Not used. Must be set to OFF.						

Since 200 words of the DM area are allotted for each setting, do not set numbers already used by other Units.

Setting No.	DM area for positioning data expansion
0	Unexpanded
1	DM 0100 to 0299
2	DM 0200 to 0399
3	DM 0300 to 0499
4	DM 0400 to 0599
5	DM 0500 to 0699
6	DM 0600 to 0799
7	DM 0700 to 0899

**Pins 1 and 4:
Output Pulse Selection**

Select the appropriate output pulse according to the motor drive specifications.

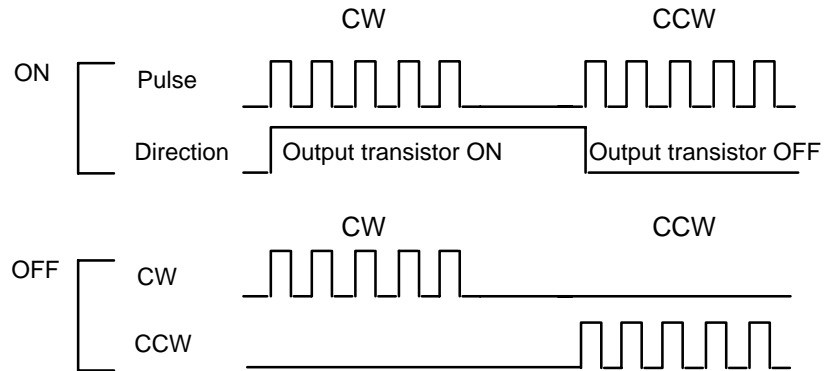

**Pins 2, 5, 3 and 6:
External Interrupts**

When pins 2 and 5 are OFF, external interrupt signals can be used both for STOP and CHANGE SPEED.

When pins 2 and 5 are ON, pins 3 and 6 can be used to set the external interrupt signal to STOP or CHANGE SPEED.

**Pins 7-9:
Assigning the DM Area for
Positioning Data Expansion**

Each Unit is allocated 20 positioning actions in the DM area for each axis. If more than 20 positioning actions are required, set pins 7-9 from 1 to 7 to expand the available DM area. Up to 33 additional positioning actions can be made available for both X and Y axes (for a total of 53, including the above).

2-3 Switch Settings Examples

Mode 0 Connection

This example shows the use of a stepping motor with an external sensor signal connected to the origin signal.

Do not make any connection to the Z-phase input (9 (X)/ 31 (Y)).

Example 1:

The following diagram illustrates connection in which only the X axis is used. The same wiring could be used to with the Y axis.

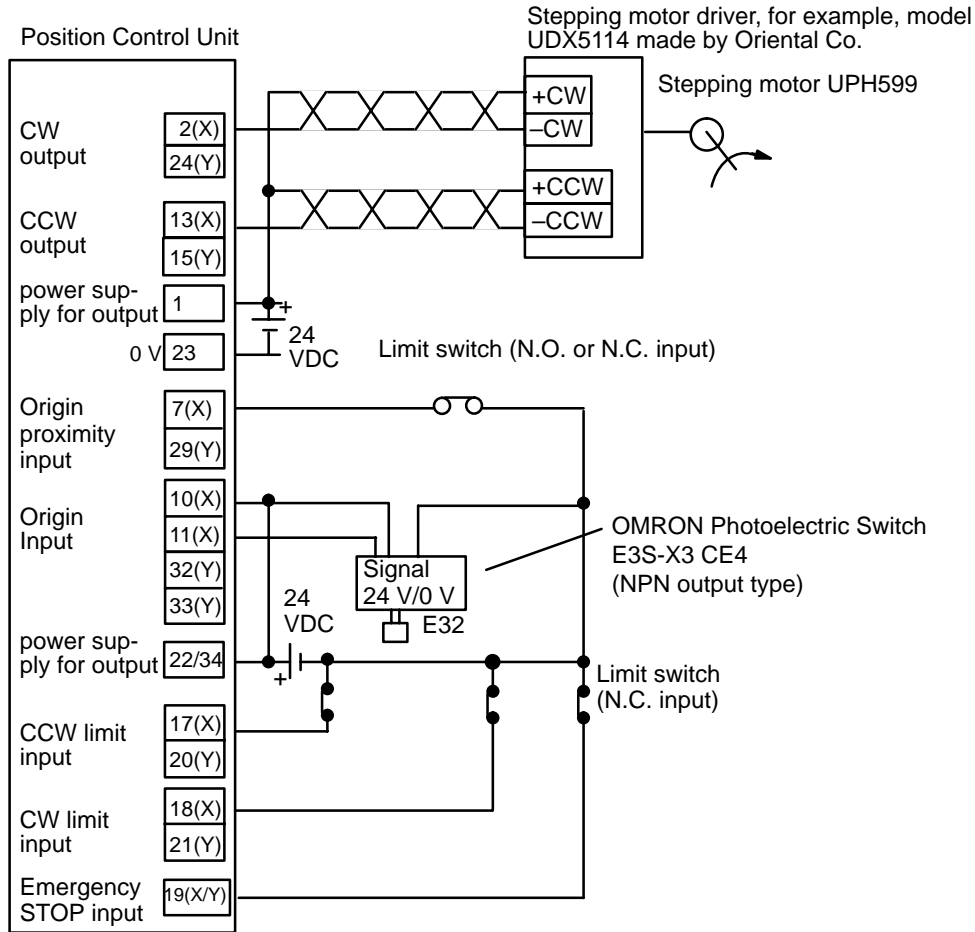

⚠ Caution When only one axis is used, short-circuit the CW limit input and CCW limit input of unused axis to 0 V in 24 VDC. If these are not short-circuited, the ERROR LED will light, although the axis in use will operate normally.

Switch Settings

Front switches

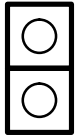

Sets the Unit No.
Sets the Mode No. to 0.

DM area settings

15 ← → 00

DM word m+21 (X axis)

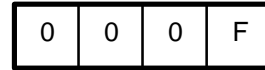

DM word m+121 (Y axis)

Back panel switch



1	OFF	CW/CCW output	X
2		External interrupt signal (See note)	
3		External interrupt signal (See note)	Y
4	OFF	CW/CCW output	
5		External interrupt signal (See note)	X/Y
6		External interrupt signal (See note)	
7		DM Area setting for position data expansion (See note)	X/Y
8		DM Area setting for position data expansion (See note)	
9		DM Area setting for position data expansion (See note)	X/Y
10	OFF	Be sure to set to OFF.	

Bit	Setting	Contents of setting
00	1	ORIGIN SEARCH direction CCW
01	1	Origin proximity exists
02	1	Origin proximity is N.O. input
03	1	Origin is N.O. input
04	0	No origin proximity reverse

Note: Refer to page 18 for settings of pins 2, 3, and 5 to 9.

ORIGIN SEARCH

Origin search is started after the rising edge of the origin proximity signal and ends with the rising edge of the origin signal.

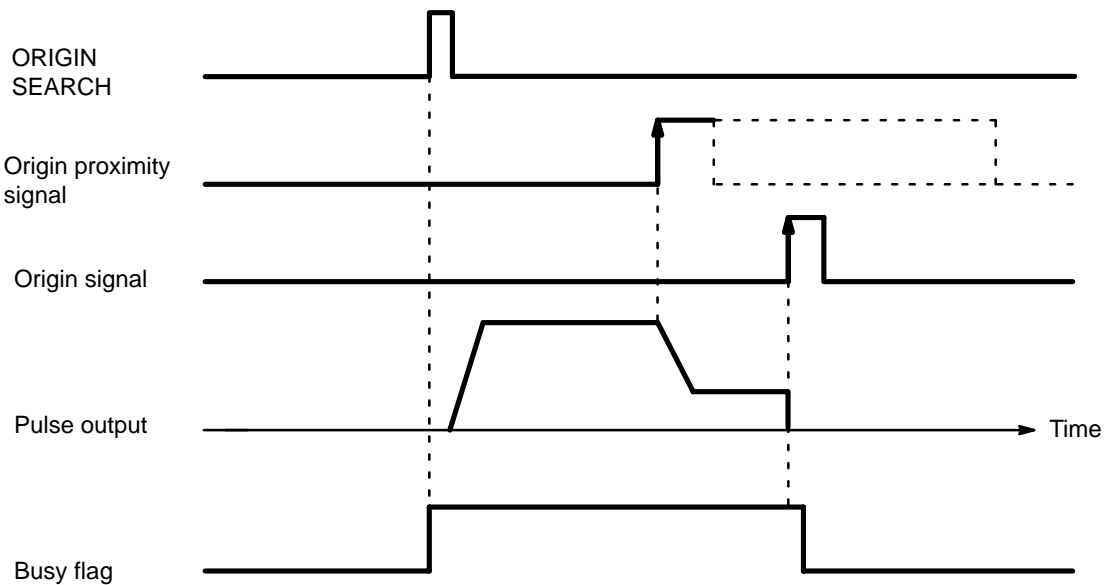

**Example 2:
Mode 1 Connection**

This example shows the use of a servomotor driver with the Z-phase of the encoder as the origin signal.

Do not connect anything to the origin signal (10 (X) /32 (Y)). This example uses an OMRON Servomotor Driver.

The following diagram illustrates connection in which only the X axis is used. The same wiring could be used for the Y axis.

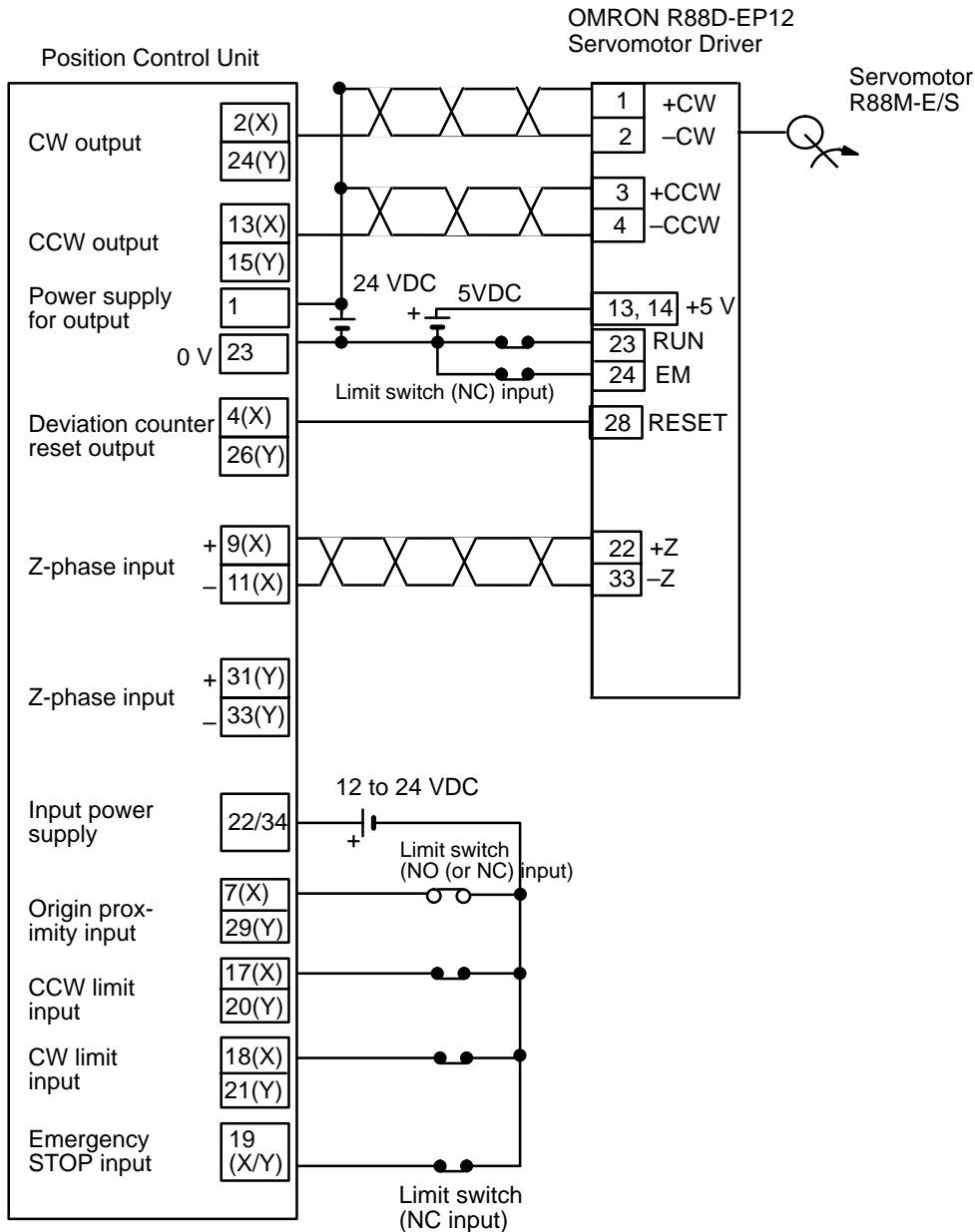

! Caution When only one axis is used, short-circuit the CW limit input and CCW limit input of unused axis to 0 V in 12 to 24 VDC. If these are not short-circuited, the ERROR LED will light, but the axis in use will operate normally.

Front switches

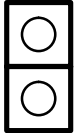

Sets the Unit No.
Sets the Mode No. to 1.

DM Area settings

DM word m+21 (X axis) 15 ← → 00
DM word m+121 (Y axis)

0	0	1	F
---	---	---	---

Back panel switch



1	OFF	CW/CCW output	X
2		External interrupt signal (See note)	
3			
4	OFF	CW/CCW output	Y
5		External interrupt signal (See note)	
6			
7		DM Area setting for position data expansion (See note)	X/Y
8			
9			
10	OFF	Be sure to set to OFF.	

Bit	Setting	Contents of setting
00	1	ORIGIN SEARCH direction CCW
01	1	Origin proximity exists
02	1	Origin proximity is N.O. input
03	1	Origin is N.O. input
04	1	Origin proximity reverse

Note: Refer to page 18 for settings of pins 2, 3, and 5 to 9.

ORIGIN SEARCH

ORIGIN SEARCH begins after the origin proximity signal has risen and fallen, and stops on completion of the first Z-phase signal after deceleration ends.

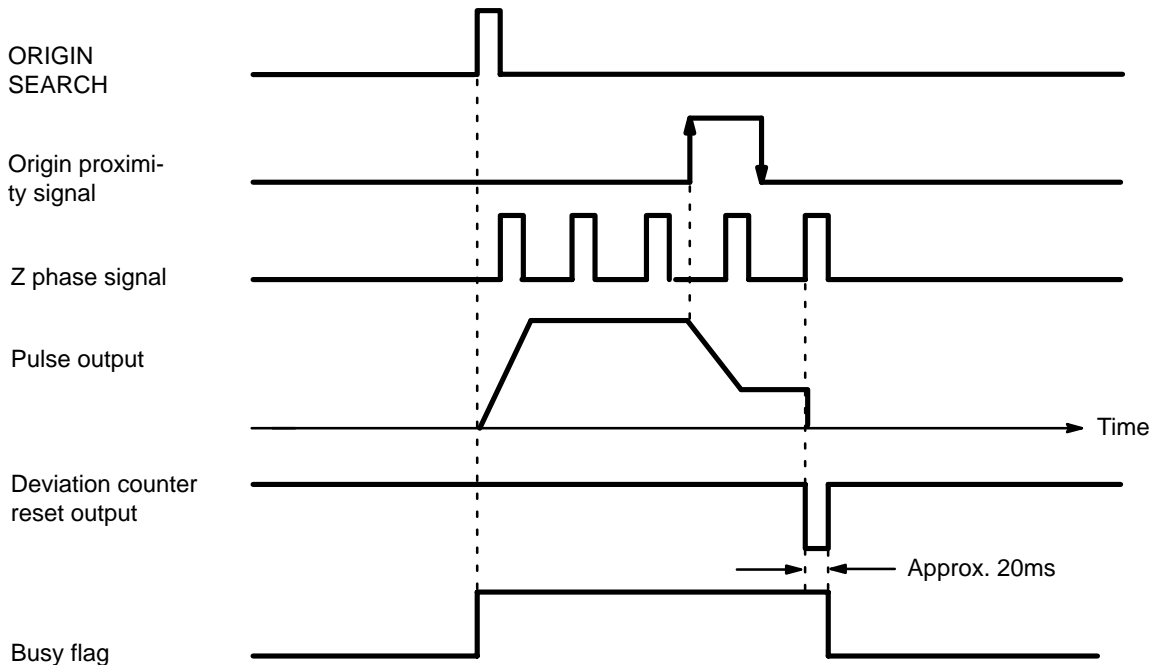

**Example 3:
Mode 2 Connection**

This example also shows a servomotor driver with the Z-phase of the encoder as the origin signal.

Here the positioning signal of the servomotor driver serves as the ORIGIN SEARCH completion and the positioning completion signals. Only the X axis is shown, although the same wiring would be used for using the Y axis.

Be sure to adjust the settings of the servomotor driver so that the positioning completion signal is OFF when the motor is operating and ON when it halts. Do not connect anything to the origin signal (10 (X) /32 (Y)).

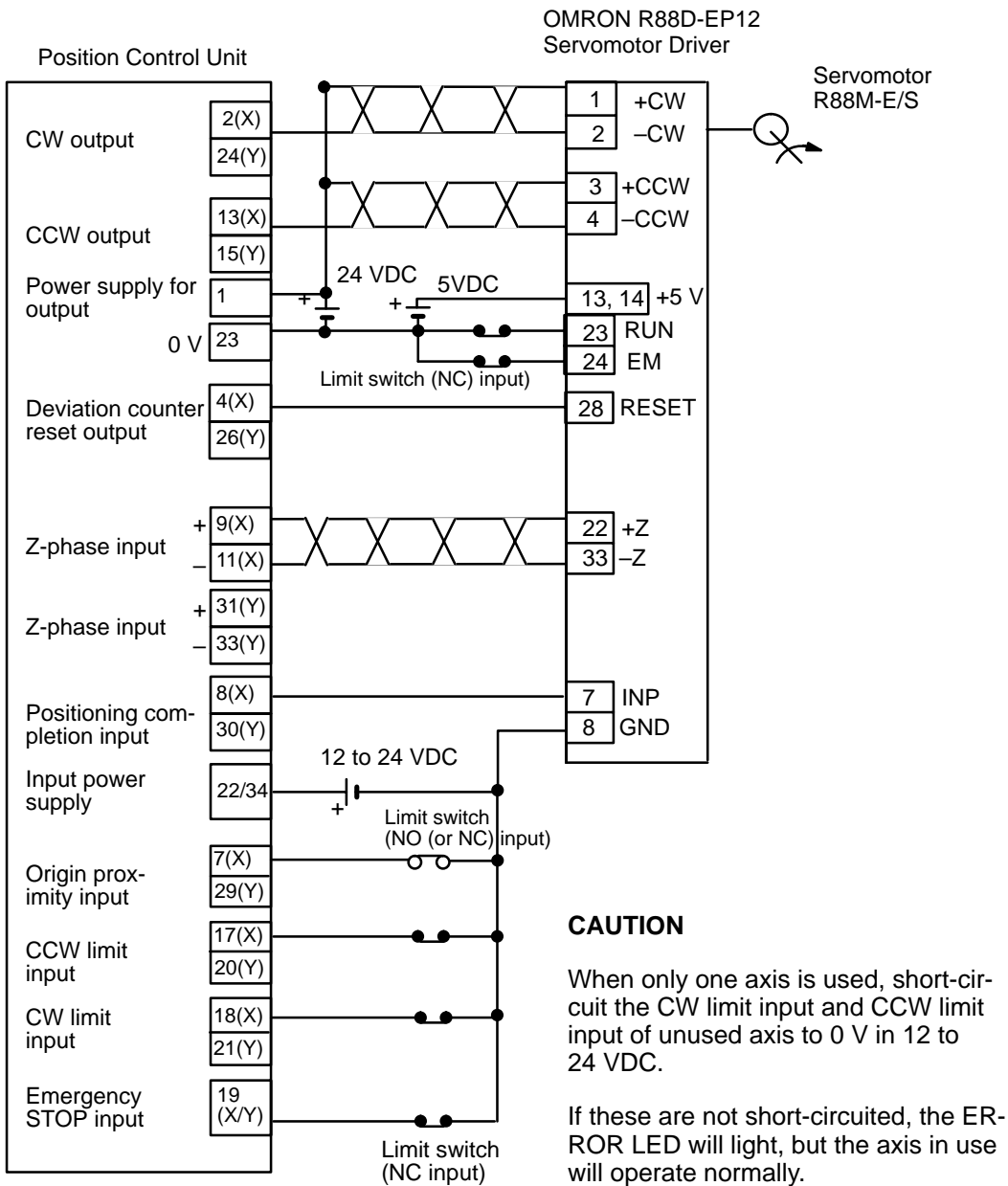

Switch Settings

Front switches

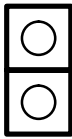

Sets the Unit No.
Sets the Mode No. to 2.

DM Area settings

DM word m+21 (X axis) 15 ← → 00
DM word m+121 (Y axis) 0 0 1 F

Back panel switch



1	OFF	CW/CCW output	X
2		External interrupt signal (See note)	
3			Y
4	OFF	CW/CCW output	
5		External interrupt signal (See note)	
6			X/Y
7		DM Area setting for position data expansion (See note)	
8			
9			
10	OFF	Be sure to set to OFF.	

Bit	Setting	Contents of setting
00	1	ORIGIN SEARCH direction CCW
01	1	Origin proximity exists
02	1	Origin proximity is N.O. input
03	1	Origin is N.O. input
04	1	Origin proximity reverse

Note: Refer to page 18 for settings of pins 2, 3, and 5 to 9.

ORIGIN SEARCH

Origin search is started after the origin proximity signal has risen and fallen, and stops with completion of the first Z-phase signal after deceleration has stopped.

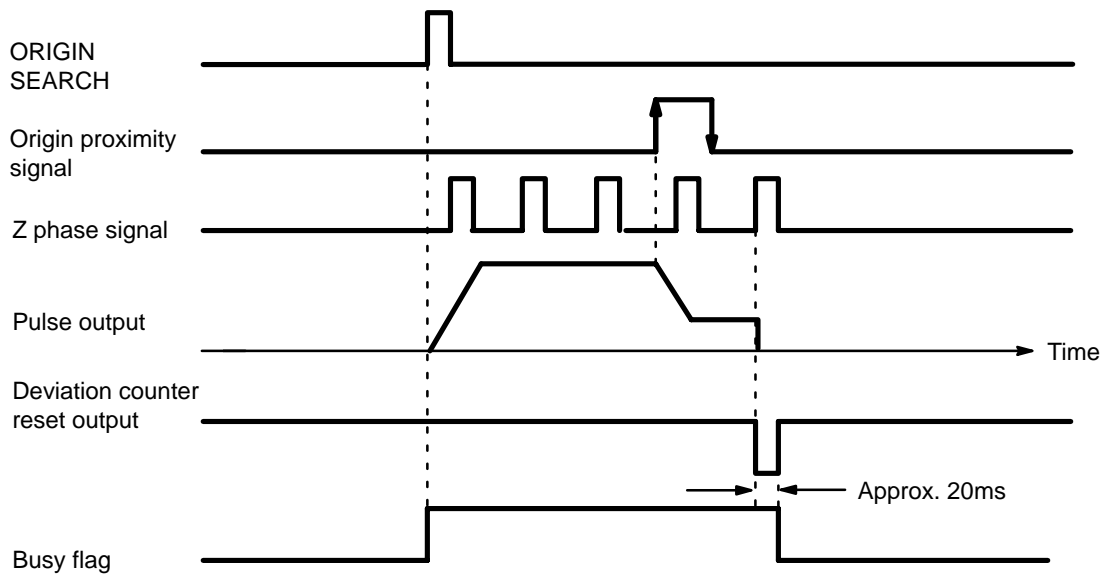

**Example 4:
Mode 3 Connection**

This is an example using the origin adjustment function of OMRON's Servomotor Drive. The positioning completion signal (INP) is used as the ORIGIN SEARCH completion and the positioning completion signal. OMRON's Servomotor Drive R88D-EP/SR allows accurate origin decompletion.

Be sure to adjust the settings of the servomotor driver so that the positioning completion signal is OFF when the motor is operating and ON when it halts.

The following diagram illustrates a connection example in which only the X axis is used. The same wiring would be used for the Y axis.

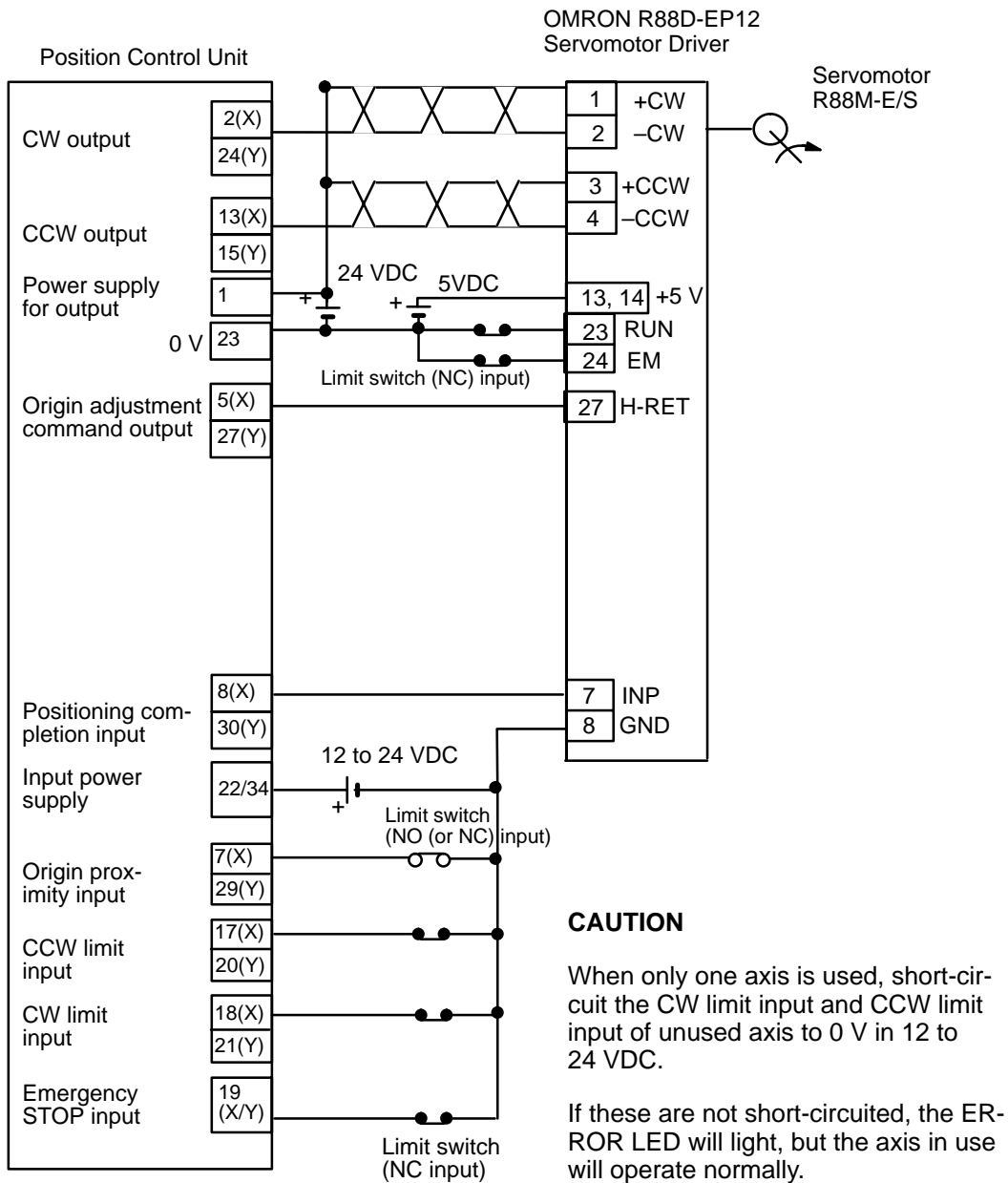

Switch Settings

Front switches

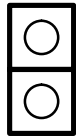

Sets the Unit No.

Sets the Mode No. to 3.

DM Area settings

15 ← → 00

DM word m+21 (X axis)

DM word m+121 (Y axis)

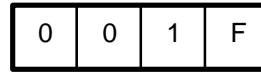

Back panel switch



1	OFF	CW/CCW output	X
2		External interrupt signal (See note)	
3			Y
4	OFF	CW/CCW output	
5		External interrupt signal (See note)	X/Y
6			
7		DM Area setting for position data expansion (See note)	X/Y
8			
9			X/Y
10	OFF	Be sure to set to OFF.	

Bit	Setting	Contents of setting
00	1	ORIGIN SEARCH direction CCW
01	1	Origin proximity exists
02	1	Origin proximity is N.O. input
03	1	Origin is N.O. input
04	1	Origin proximity reverse

Note: Refer to page 18 for settings of pins 2, 3, and 5 to 9.

ORIGIN SEARCH

ORIGIN SEARCH begins after the origin proximity signal has risen and fallen, and the origin adjustment command is output to the servomotor driver after deceleration ends. The positioning completed signal is then input from the servomotor driver and origin search ends. The driver stops automatically with the first Z-phase input after it has received the origin adjustment signal.

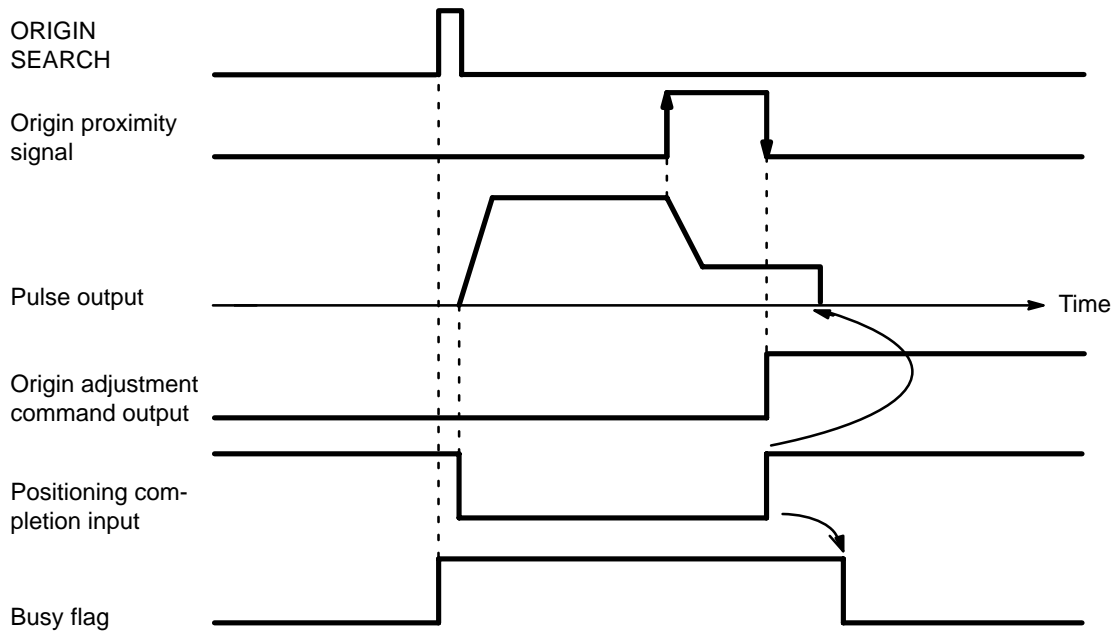

2-4 Wiring

External Input Connection Method The following diagram shows I/O connections.

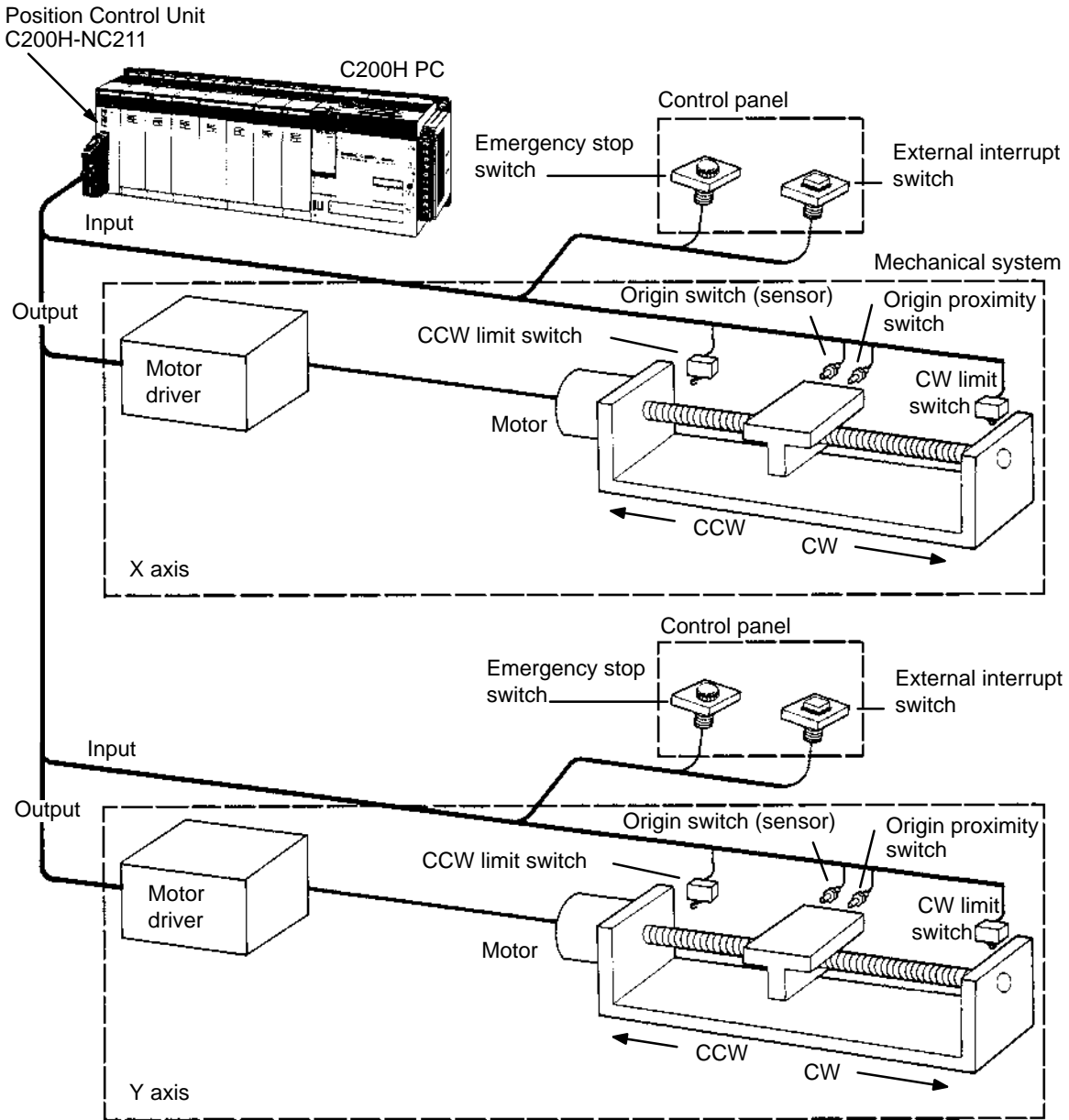

Connector Pin Arrangement The following shows the I/O connector arrangement as viewed from the front of the Position Control Unit.

Pin No	Designation	Pin No	Designation	Pin No	Designation
12	FG (frame ground)			34	X/Y axis for input (12-24 VDC)
11	X-axis Origin (0 V/-Z)			33	Y-axis Origin (0 V/-Z)
10	X-axis Origin input (12-24 VDC)	22	X/Y axis for input (12-24 VDC)	32	Y-axis Origin input (12-24 VDC)
9	X-axis Origin driver input (+Z)	21	Y-axis CW limit input (0 V)	31	Y-axis Origin driver input (+Z)
8	X-axis Positioning completion input (0 V)	20	Y-axis CCW limit input (0 V)	30	Y-axis Positioning completion input (0 V)
7	X-axis Origin proximity input (0 V)	19	X/Y axis Emergency stop input (0 V)	29	Y-axis Positioning proximity input (0 V)
6	X-axis External interrupt input (0 V)	18	X-axis CW limit input (0 V)	28	Y-axis External interrupt input (0 V)
5	X-axis (open collector) Origin-adjustment command output	17	X-axis CCW limit input	27	Y-axis (open collector) Origin-adjustment command output
4	X-axis (open collector) Deviation counter reset output	16	Y-axis CCW pulse/direction output	26	Y-axis (open collector) Deviation counter reset output
3	X-axis CW pulse/pulse output	15	Y-axis (with 1.6K Ω resistance) CCW pulse/direction output	25	Y-axis CW pulse/pulse output
2	X-axis (with 1.6K Ω resistance) CW pulse/pulse output	14	X-axis CCW pulse/direction output	24	Y-axis (with 1.6K Ω resistance) CW pulse/pulse output
1	Output power supply 24 VDC	13	X-axis (with 1.6K Ω resistance) CCW pulse/direction output	23	Output power supply 0 V

- Note**
1. The common sides of each output (2-5, 13-16, 24-27) are all short-circuited to No. 23 pin output power supplies (0 V).
 2. The common sides of all inputs apart from the origin inputs and origin line driver inputs (6-8, 17-21, 28-30) are all short-circuited through diodes to the common for No. 22/34 pin input (12-24 V DC).
 3. Origin common 11 is paired with 9 or 10, and 33 is paired with 31 or 32.

External wiring connectors The external wiring connectors are item MR-34LF, made by Honda Telecommunications Industries (soldered type, included with main unit).

 **Caution**

- Use 24 \pm 10% VDC as the pulse output power supply.
- Use **either** the origin input (10, 11/32, 33) **or** the origin line driver input (9, 11/31, 33), but **not both**.
- The leakage current must be less than 1.3 mA when two-wire type sensors are used.
- When only one axis is used, short-circuit the CW limit input and CCW limit input of the unused axis to the 0 V in 12 to 24 VDC. If it is not short-circuited, the ERROR LED with light, but the axis in use will operate normally.

Connector Wiring Method

- Use solder to attach the connectors accompanying the unit.
- Use wires with cross-sectional areas of 0.3 mm^2 or less.
- Take care not to short-circuit neighboring terminals when soldering.
- Cover the soldered part of the wire with insulation tubing.
- When using a multi-core cable, wire output and input separately.

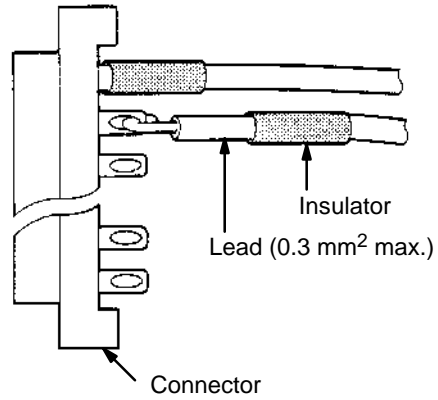
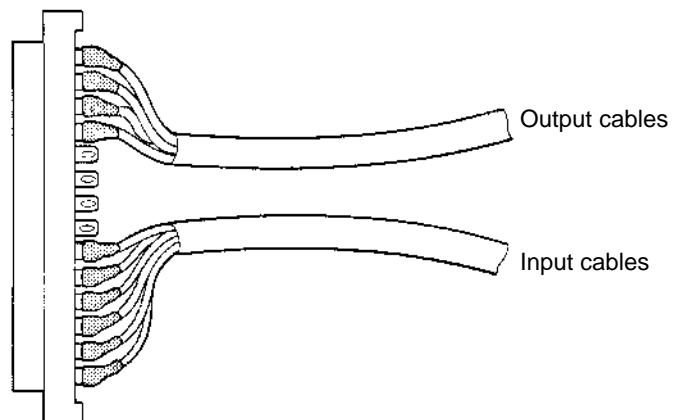
**Differentiating Cables**

Assembling Connectors

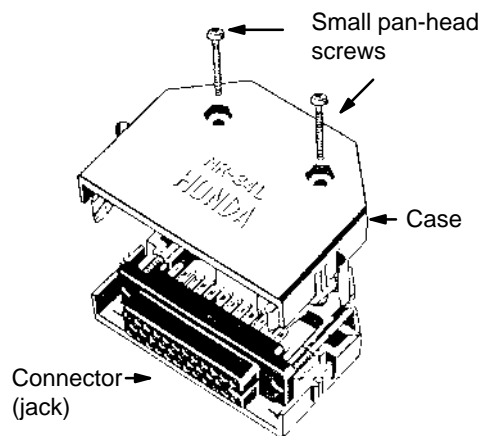

Outputs

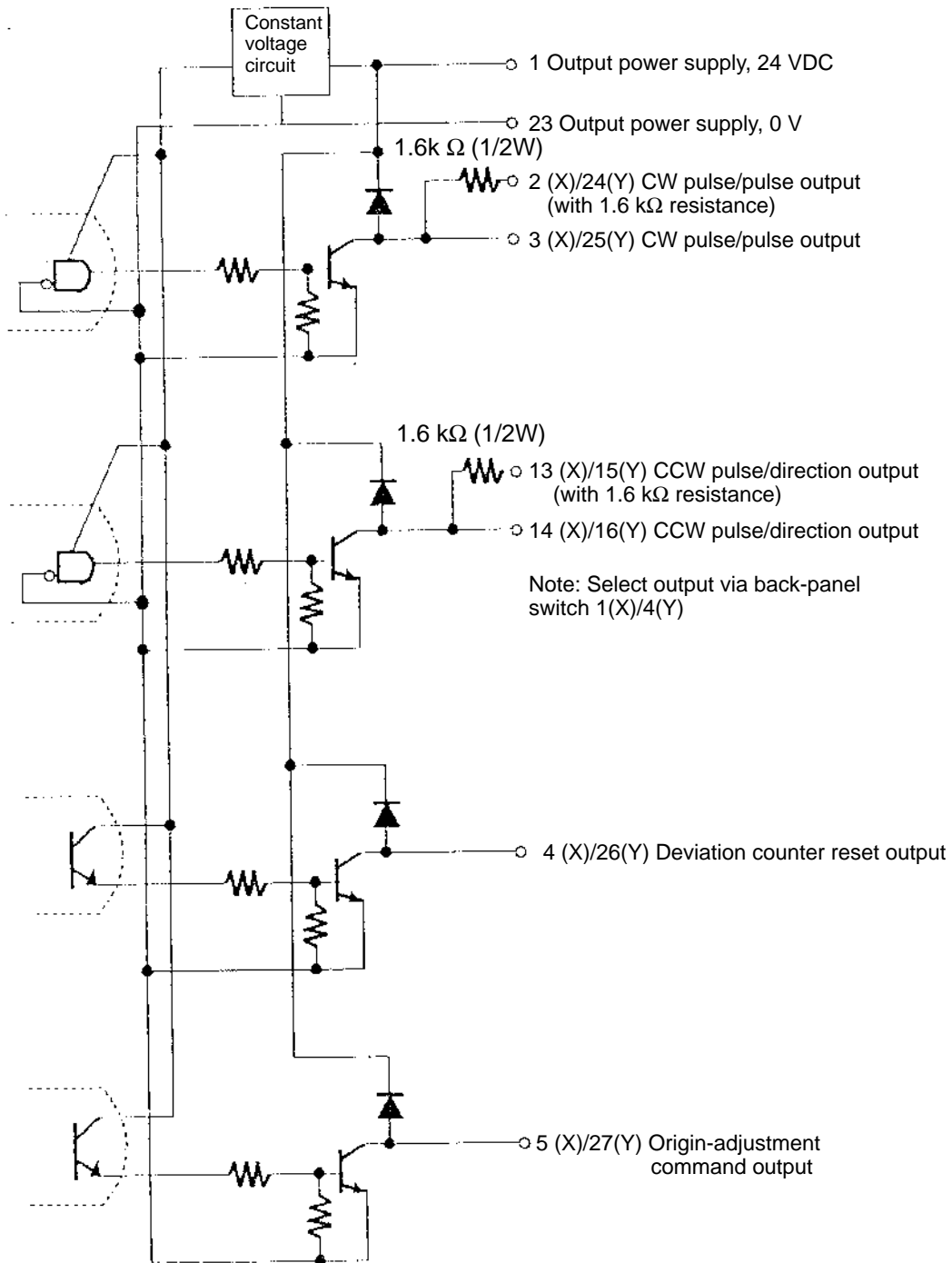

Inputs

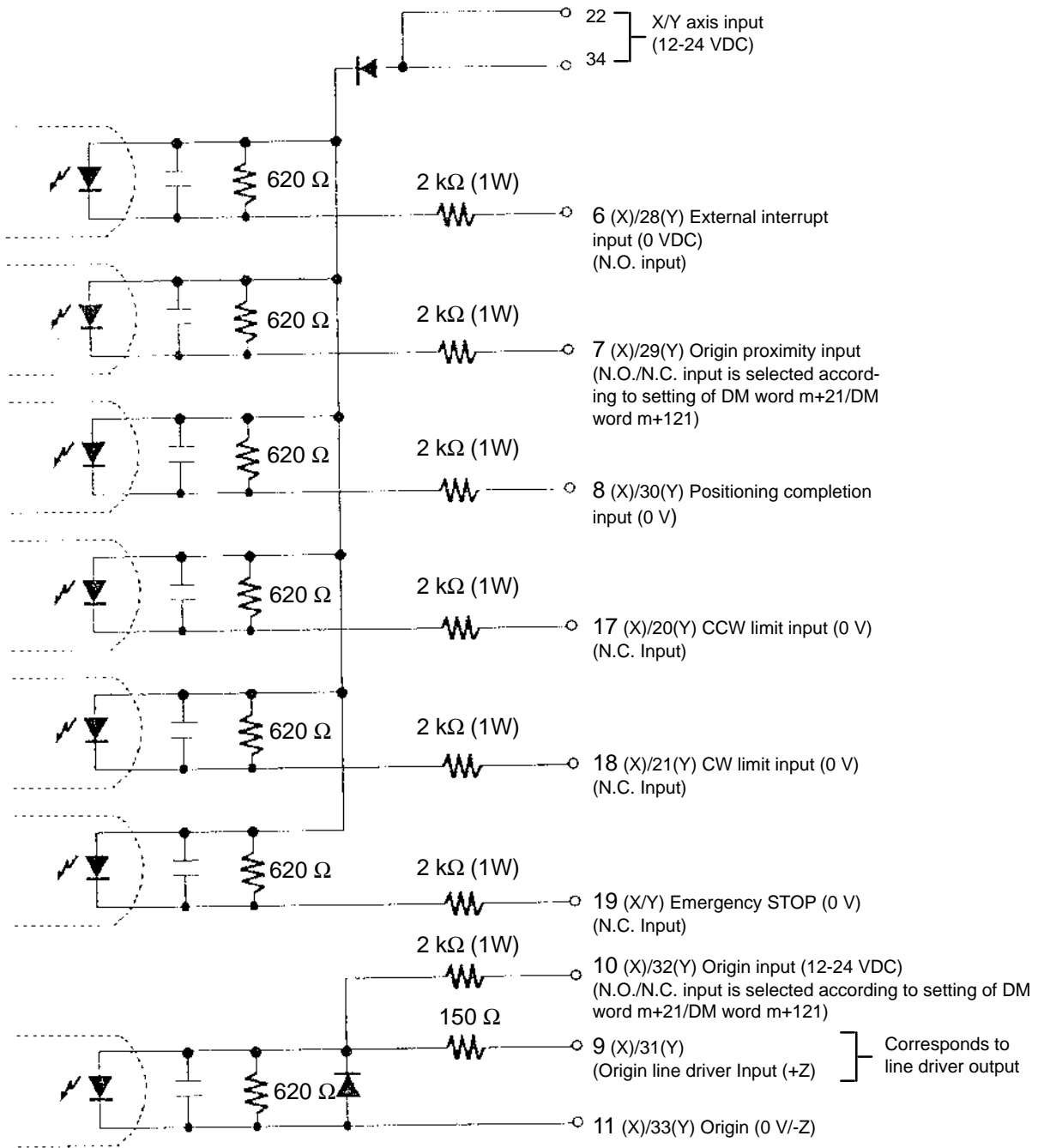

- Connect the open/close power switch for above 12 mA, except for the origin line driver input.
- For the origin input/origin line driver:
 - X axis: (10, 11)/(9, 11)
 - Y axis: (32, 33)/31, 33)

Mode 0: Response time is 1 ms.

This mode is used when sensors and other open collector outputs are connected.

Mode 1/2: Response time is 0.1 ms

These modes are used when the encoder's Z-phase output (line driver output) is connected.



Caution

Use **either** (10,11) and (9,11) **or** (32,33) and (31,33), but **not both**. Connecting both may damage the internal circuit.

2-4-1 Output Connection Examples

The diagrams on the following pages illustrate examples of connections to motor drivers. Always confirm motor driver specifications before making connections. Connect between 7 mA and 30 mA loads to the outputs of the Position Control Unit, or add bypass resistance for loads less than 7 mA.

The built-in 1.6 kΩ resistors can be used as bypass resistors. If, as in the following example diagram, the load current is 4 mA, then: Output transistor current (7 mA) = Load current (4 mA) + Bypass current (3 mA).

The output circuit of the Position Control Unit is provided with 1.6 kΩ (1/2 W) resistors. Use these resistors in accordance with the power requirements and the specifications of the motor driver to be used.

Open collector output

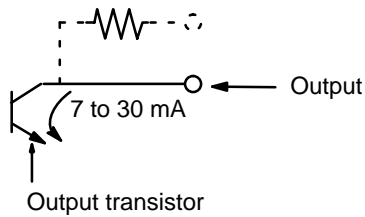

Open collector output with 1.6 kΩ series resistance

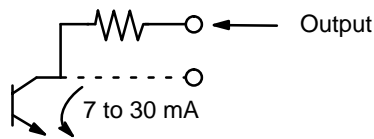

Open collector output

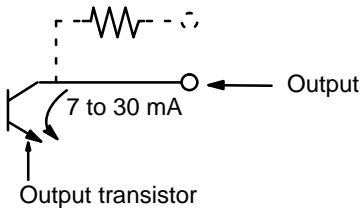

Open collector output with 1.6 kΩ parallel resistance

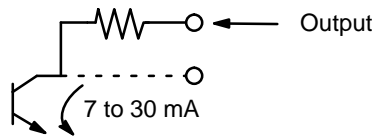

Pulses are not output when the output transistor in the pulse output section is OFF. (For direction output, OFF indicates CCW.)



**Example 1:
Outputting CW and CCW
Pulses**

In this example, the 1.6 kΩ resistors of the Position Control Unit are used to allow a 24-VDC power supply to be used with a motor driver rated at 5 VDC.

When wiring your system, carefully note the current required by the motor driver.

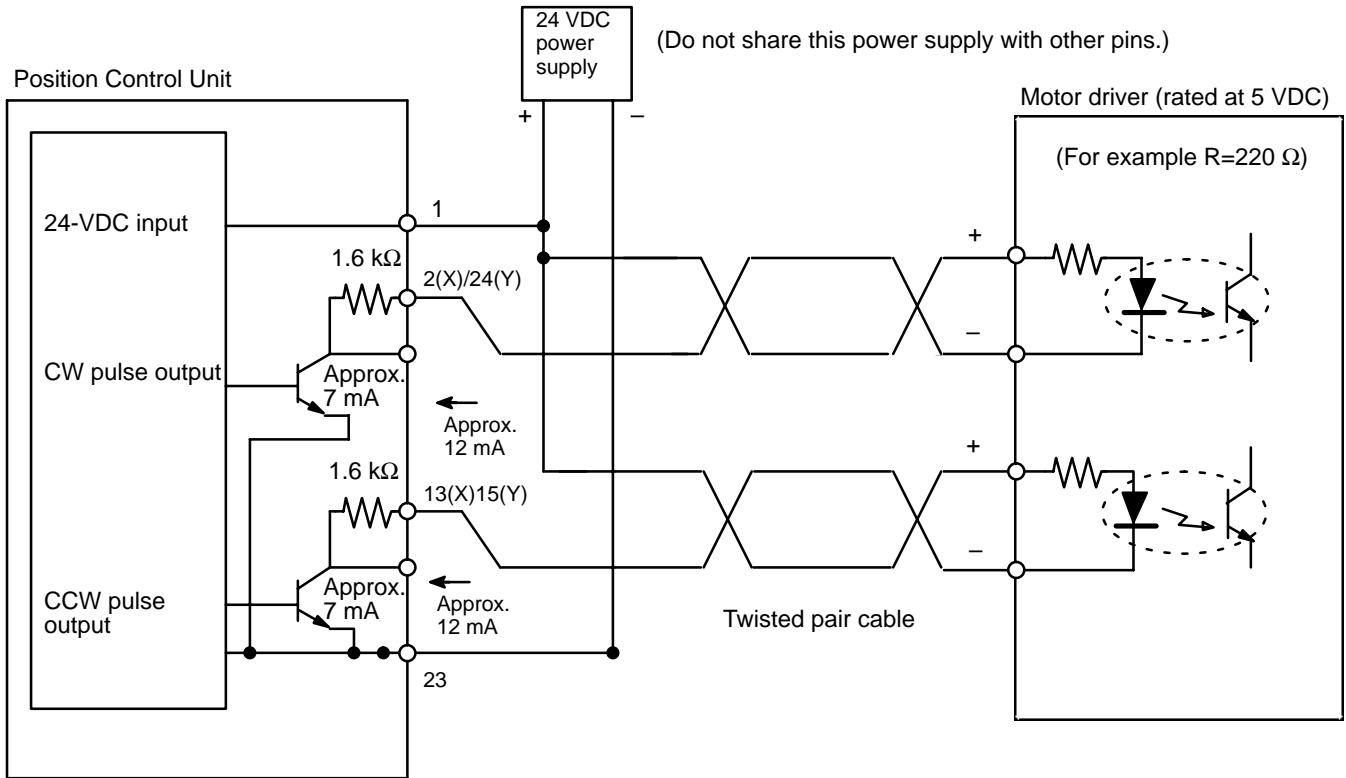

⚠ Caution Beware of the danger of electric shock from the motor driver.

**Example 2:
Outputting Pulse and
Direction Signals with a
24-VDC Supply**

When the Position Control Unit is used to output voltage levels, the low level is obtained when the output transistor turns ON, while the level goes high when the transistor turns OFF. When voltage-level output is used, the level is L for output ON, and H for output OFF.

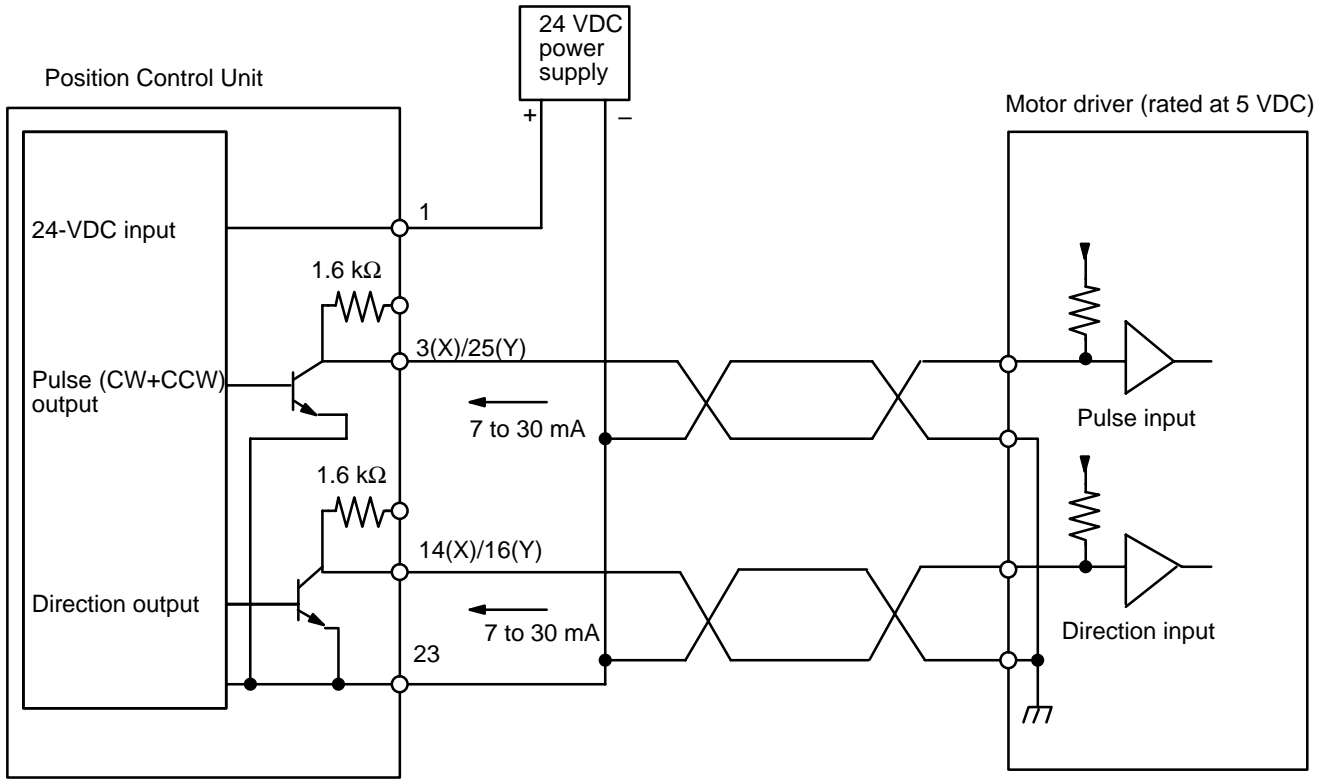

**Example 3:
Deviation Counter Reset
Output**

There is approximately 20 ms of output when ORIGIN SEARCH is completed in Modes 1 or 2.

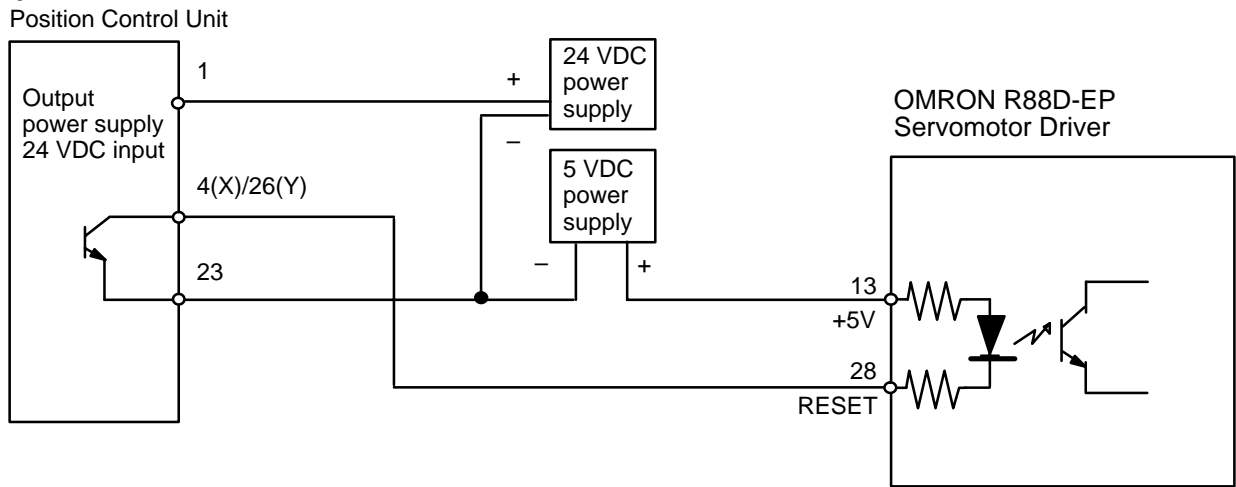

**Example 4:
Origin Adjustment
Command Output**

This example shows output in Mode 3.

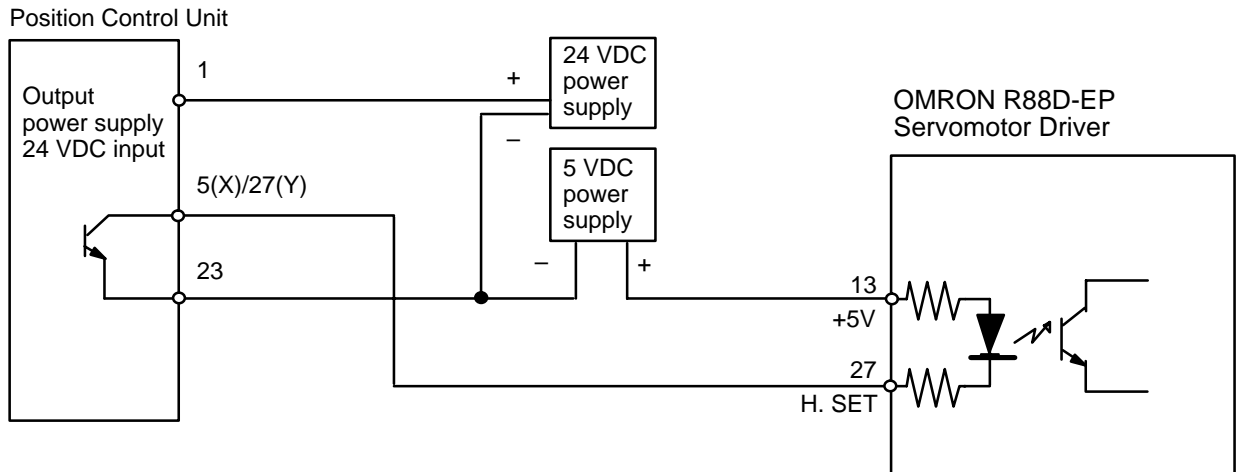

2-4-2 Input Connection Examples

The respective inputs are N.O. (normally open) and N.C. (normally closed). When not used, leave the N.O. input pins open, and the N.C. input pins connected to the power supply.

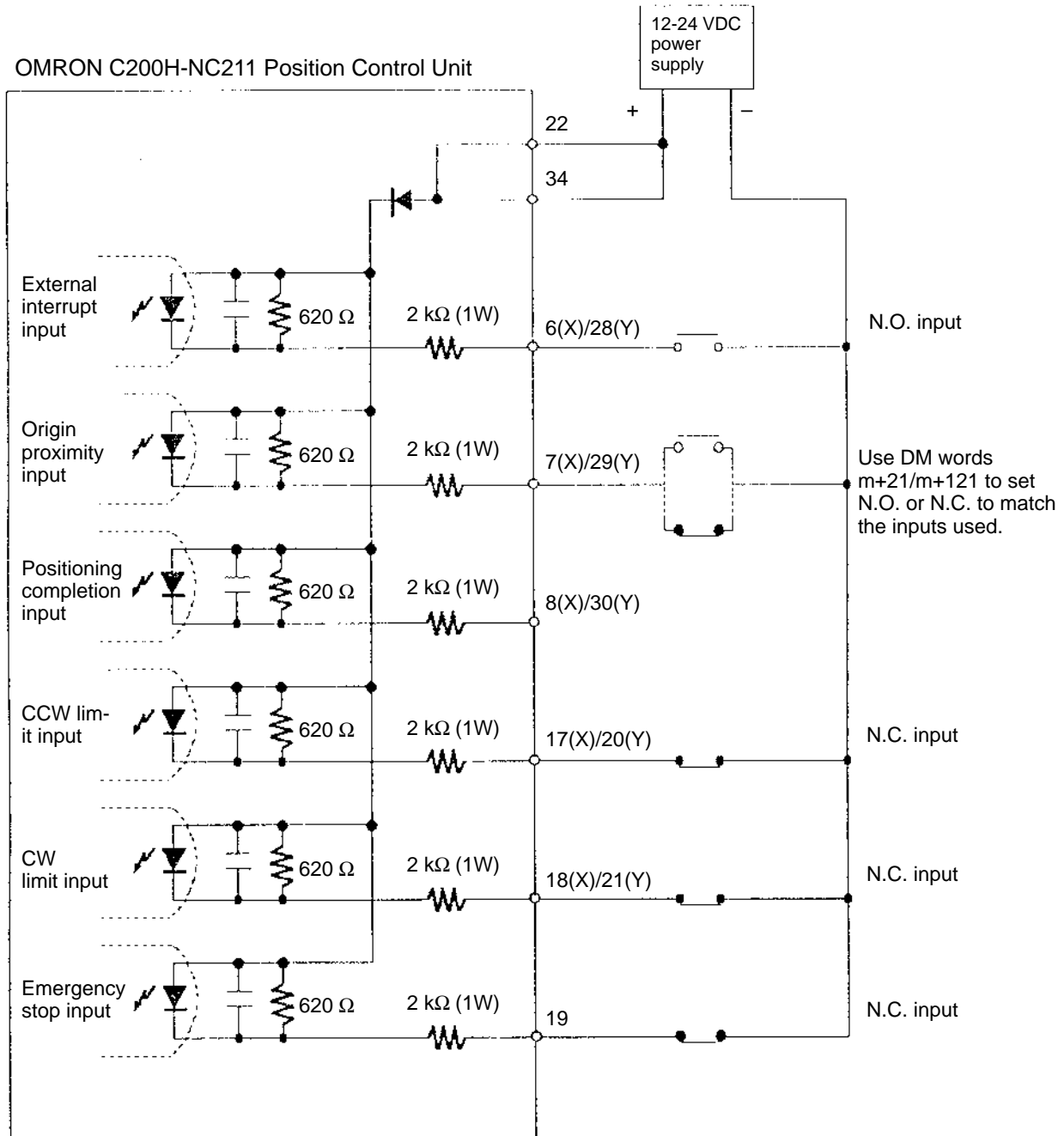

Note Connect the switch for open/close power of 12 mA for each input.

Origin Input Connection Examples

The examples below shows input connection when open collector sensor output and the encoder's Z-phase line driver output are used.

Origin Input (10-11 (X)/32-33 (Y))

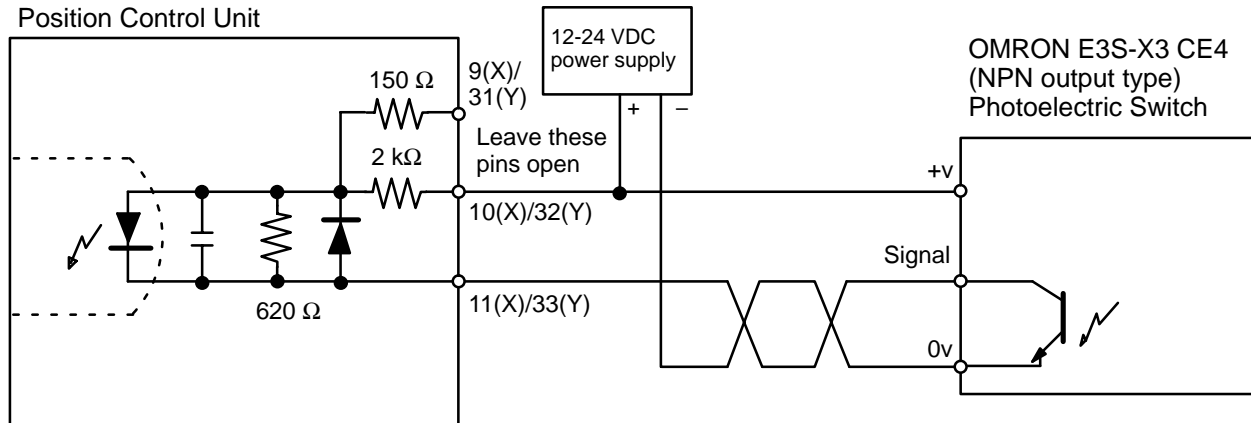

Origin Line Driver Input (9-11 (X) /31-33 (Y))

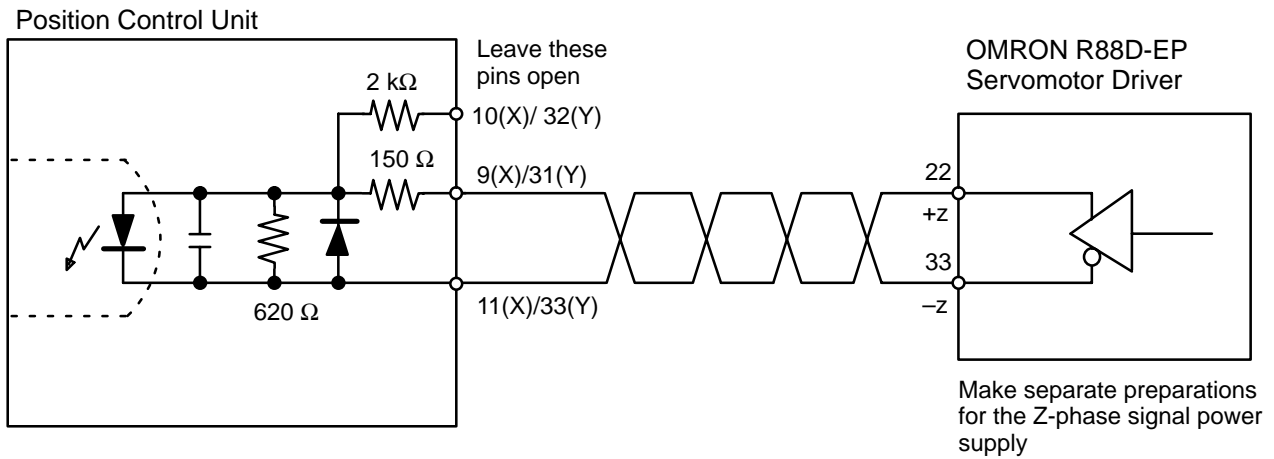

Positioning Completion Connection Example

The positioning completed input signal is also used as an origin search completed signal in modes 2 and 3. Adjust the setting of the servomotor driver so that this signal always turns off while the servomotor is operating, and on when the motor stops.

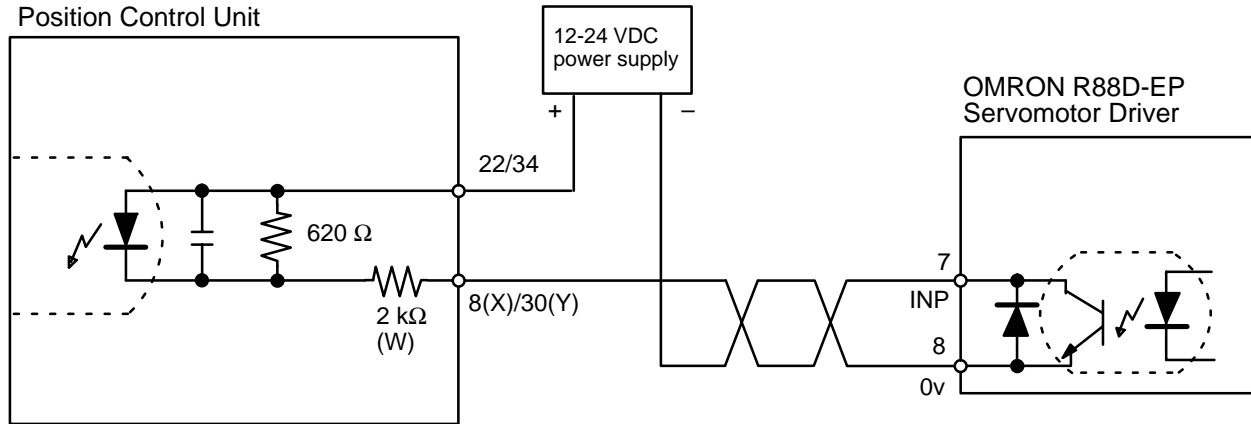

2-4-3 Wiring Precautions

Operational errors can occur in most electronic control devices if they are subjected to electronic noise from nearby power lines or loads. Recovery from such errors is usually very difficult and time consuming. To avoid such noise-generated operational errors and improve system reliability, always observe the following precautions in wiring the system.

- Cables must be of the required diameter.
- Power lines (e.g., AC power supply, motor power line) and control lines (e.g., pulse output lines, external I/O signal lines) must be wired separately. Never put these lines into the same duct or make them into a single bundle.
- Use shielded cable for control lines.
- Attach a surge absorber to all inductive loads, such as relays, solenoids, and solenoid valves.

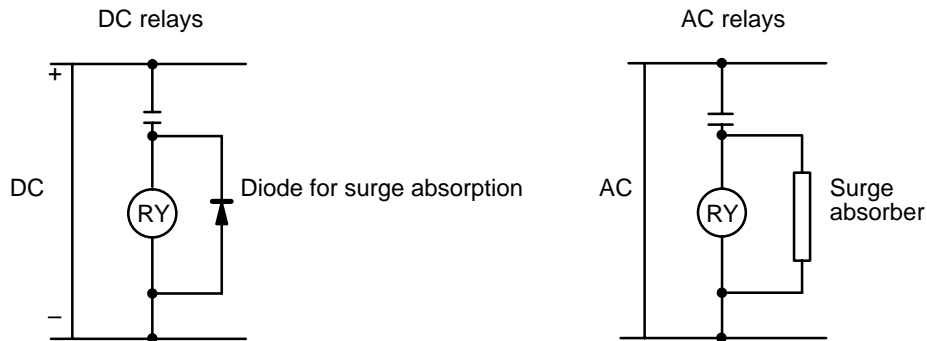

Note Connect the diode and surge absorber as close as possible to the relay. Use a diode capable of withstanding a voltage five times higher than the circuit voltage.

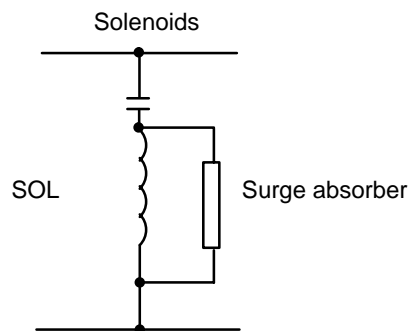

- Insert a noise filter into the power supply inlet if noise enters the power line (e.g., when it is connected to the same power supply as an electric welder or an electric spark machine or when there is any supply generating high frequency noise).
- Twisted pair cable is recommended for power lines.
- Use No. 3 or greater grounding contacts, and the thickest possible wire, greater than 1.25 mm².

2-5 Dimensions

Unit Dimensions (unit: mm)

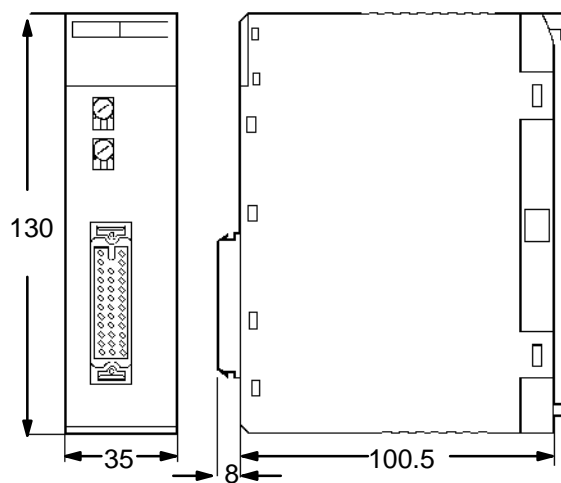

Mounted Dimensions (unit: mm)

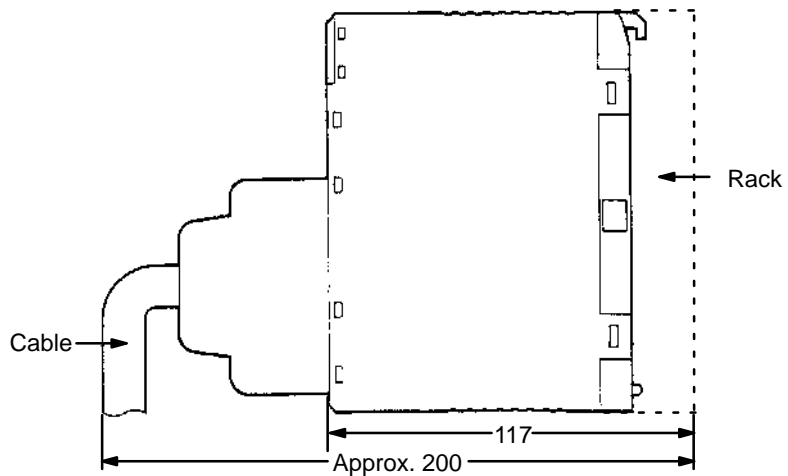

SECTION 3

Operation

3-1	Wiring Data	50
3-2	Data Configuration and Allocation	52
3-3	DM Area Allocation	54

Section Overview

This section covers all aspects of Position Control Unit operation other than commands, which are covered in the following section. Included in this section are the basic operating procedure, the type of output pulses possible, the basic data format and configuration, some special features to aid operation, such as flags, zone settings, backlash compensation and internal limits, and the internal data calculation methods used in processing user-input data.

3-1 Wiring Data

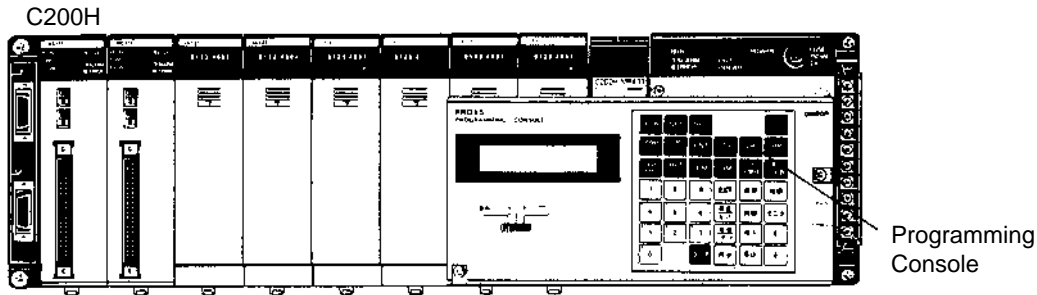

Data is written, via the Programming Console, or any other programming device into the section of the DM area designated for Special I/O Units. The specific words are DM 1000-1999, with 200 of these words allocated for each unit number assigned to a Position Control Unit. Written data is effective the next time power is turned on or when the system is restarted with the restart bit in the AR area. To write data, use the 3-word change operation of the Programming Console.

Programming Console Display

D1824	D1823	D1822
0012	5000	2000

Key Input Sequence

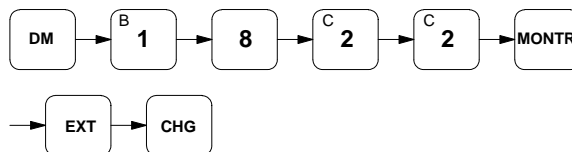

The above procedure prepares memory location DM 1824 so that new data can be keyed in. Pressing the CHG key again moves the cursor to DM 1823. After inputting data, press the write key to execute the rewrite. The above example shows X axis positioning action #0 of Unit #8.

Special I/O Unit Restart Bits

AR Word Bits 100-109

Restart bits can be used to transfer altered DM area data to the Unit without turning power off and on. Modified DM data is sent immediately to the Unit. Refer to the following table for restart bit allocations. The following example of Programming Console operation shows how to access the restart bit for Unit #0. The ladder diagram section after it shows how to achieve the same operation through programming.

Restart Bits

These restart bits are turned ON and back OFF again to restart Special I/O Units.

Bit	Unit Number
AR 0100	0
AR 0101	1
AR 0102	2
AR 0103	3
AR 0104	4
AR 0105	5
AR 0106	6
AR 0107	7
AR 0108	8
AR 0109	9

Programming Console Display

```
A0101
^OFF
```

Key Input Sequence

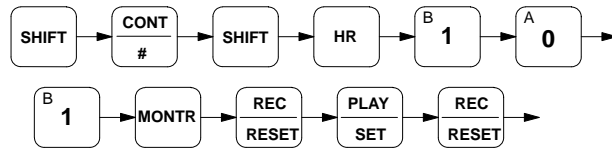

Program Example: Unit #1

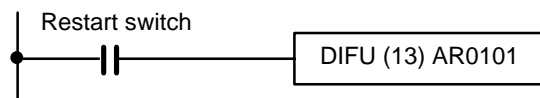

3-2 Data Configuration and Allocation

IR words 100 through 199 are allocated as Special I/O areas. Each Position Control Unit is allocated twenty consecutive words. The first word for each Unit, designated in this manual as n, can be computed from the unit number as follows:

$$n = 100 + 10 \times \text{unit number.}$$

IR Example

1	unit #	0
---	--------	---

1	unit #	9
---	--------	---

Each Unit is also allocated 200 consecutive words as a fixed data area. These words are in the DM area and run from DM 1000 through DM 1999. The first word for each Unit, m, can also be computed from the unit number:

$$m = 1000 + 100 \times \text{unit number (for the X-axis settings).}$$

$$m = 1100 + 100 \times \text{unit number (for the Y-axis settings).}$$

DM Example

1	unit #	0	0
---	--------	---	---

1	unit #	9	9
---	--------	---	---

These allocations are shown on the following page for all unit numbers. Details of allocations within these words are given under the operations or commands to which they apply. The tables on the following pages give a quick overview of word and bit allocations.

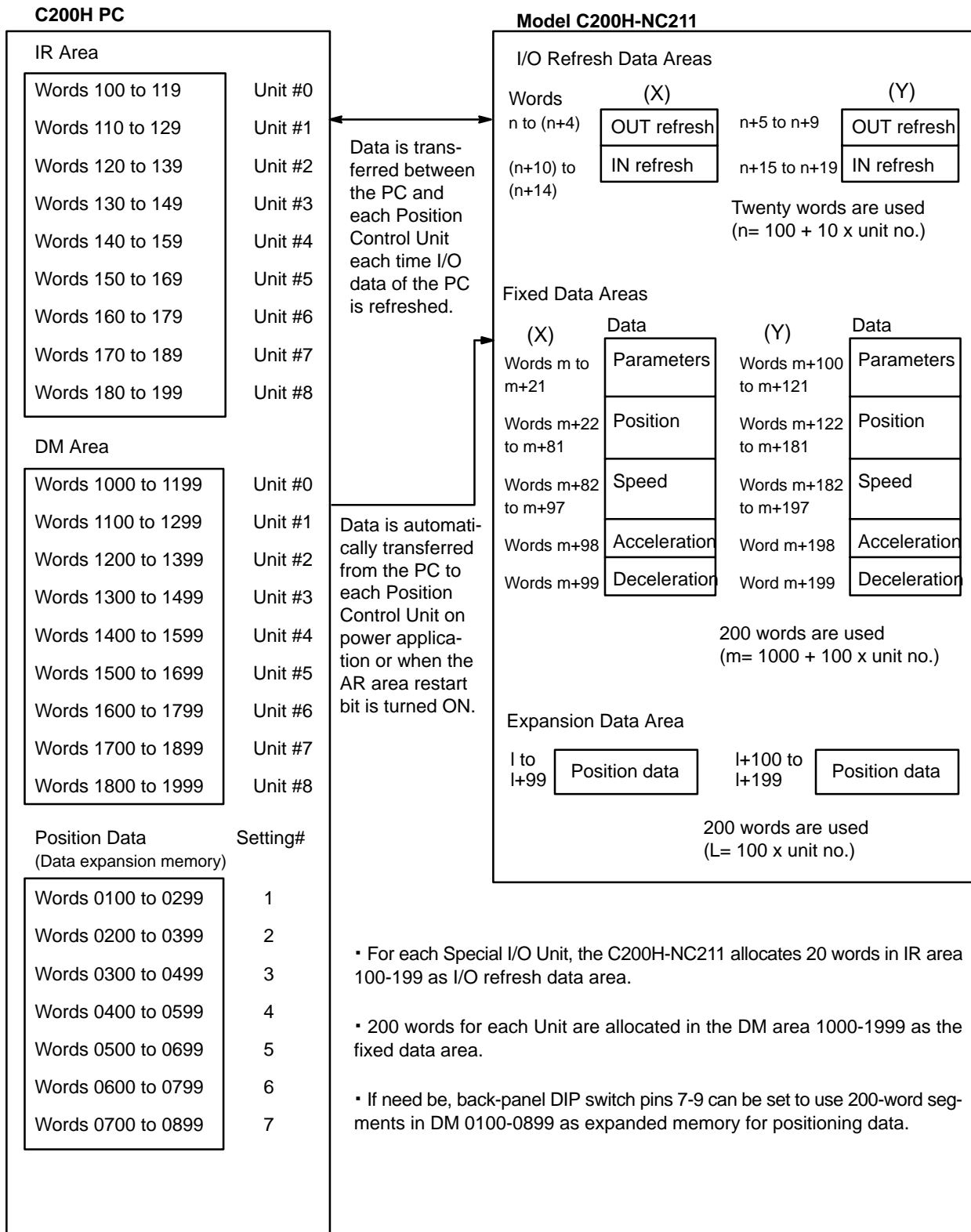

3-3 DM Area Allocation

Data Coding

Although decimal notation is generally used for data in this manual, data is handled in the system as binary-coded decimal (BCD) unless otherwise noted. Note that this data is generally input as decimal, whereas hexadecimal data is input as hexadecimal. The number of digits given for certain data refers to the decimal digits. For example, "7 digits with direction" indicates that the lowest word and rightmost 12 bits of the highest word are allocated to the 7-digit decimal value; the leftmost four bits are allocated to the direction digit.

Coding Sheets

The tables on the following pages can serve as general coding sheets for the DM area, both X and Y axes. Information describing the functions of all of the bits in the DM area is presented beginning on page 57.

The numbers shown for the DM words in the following table represent only the final two digits of each word number. In other words, the first two digits (which would be the same for all words) are not shown. The X-axis value of the first two digits can be obtained by computing the first DM word allocated to the Unit. This word, designated m , is equal to 1000 plus 100 times the unit number. Thus, for example, it would be 1000 for Unit no. 0, 1100 for Unit no. 1, and so on. For the Y-axis, the word m is equal to 1000 plus 200 times the unit number. The Y-axis value for Unit no. 1 would be 1200.

DM Area Coding Sheet A1

Unit no. Axis

DM 1_00 to 1_99

X axis: Unit no.
Y axis: Unit no. +1

W	15	00	Function	W	15	00	Function	W	15	00	Function		
00			Initial position nos.; speed nos.				Transfer no. <input type="checkbox"/>				Transfer no. <input type="checkbox"/>		
01				34			Positioning action #4	4	67		Positioning action #15		
02			Origin compensation and direction 0-9999	35					68				
03				36					69				
04			Backlash compensation 0-9999	37			Positioning action #5	5	70		Positioning action #16		
05			CW limit	38					71				
06	0				39					72			
07			CCW limit	40			Positioning action #6	6	73		Positioning action #17		
08	0				41					74			
09			Zone 0 CW limit	42						75			
10					43			Positioning action #7	7	76		Positioning action #18	
11			Zone 0 CCW limit	44						77			
12					45						78		
13			Zone 1 CW limit	46			Positioning action #8	8	79		Positioning action #19		
14					47					80			
15			Zone 1 CCW limit	48						81			
16					49			Positioning action #9	9	82		Speed #1	
17			Zone 2 CW limit	50						83		Speed #2	
18					51						84		Speed #3
19			Zone 2 CCW limit	52			Positioning action #10	10	85		Speed #4		
20					53						86		Speed #5
21	0	0	Origin signal type	54						87		Speed #6	
22			Positioning action #0	0	55		Positioning action #11	11	88		Speed #7		
23					56						89		Speed #8
24					57						90		Speed #9
25			Positioning action #1	1	58		Positioning action #12	12	91		Speed #10		
26					59						92		Speed #11
27					60						93		Speed #12
28			Positioning action #2	2	61		Positioning action #13	13	94		Speed #13		
29					62						95		Speed #14
30					63						96		Speed #15
31			Positioning action #3	3	64		Positioning action #14	14	97		Speed units		
32					65						98		Acceleration
33					66						99		Deceleration

DM Area Coding Sheet A2

Unit no. Axis

DM 0_00 to 0_98

X axis: DIP SW setting
Y axis: DIP SW setting+1

W	15	00	Function	W	15	00	Function	W	15	00	Function		
			Transfer no. <input type="checkbox"/>				Transfer no. <input type="checkbox"/>				Transfer no. <input type="checkbox"/>		
00			Positioning action #20	20	33		Positioning action #31	31	66		Positioning action #42		
01					34					67			
02						35						68	
03			Positioning action #21	21	36		Positioning action #32	32	69		Positioning action #43		
04					37					70			
05						38						71	
06			Positioning action #22	22	39		Positioning action #33	33	72		Positioning action #44		
07					40					73			
08						41						74	
09			Positioning action #23	23	42		Positioning action #34	34	75		Positioning action #45		
10					43					76			
11						44						77	
12			Positioning action #24	24	45		Positioning action #34	35	78		Positioning action #46		
13					46					79			
14						47						80	
15			Positioning action #25	25	48		Positioning action #36	36	81		Positioning action #47		
16					49					82			
17						50						83	
18			Positioning action #26	26	51		Positioning action #37	37	84		Positioning action #48		
19					52					85			
20						53						86	
21			Positioning action #27	27	54		Positioning action #38	38	87		Positioning action #49		
22					55					88			
23						56						89	
24			Positioning action #28	28	57		Positioning action #39	39	90		Positioning action #50		
25					58					91			
26						59						92	
27			Positioning action #29	29	60		Positioning action #40	40	93		Positioning action #51		
28					61					94			
29						62						95	
30			Positioning action #30	30	63		Positioning action #41	41	96		Positioning action #52		
31					64					97			
32						65						98	

DM Area Allocations

Word		Bit	Function				
X axis	Y axis						
m	m + 100	07 to 00	Initial position no., 00 to 52 (BCD): Initial START and START after bank end.				
		11 to 08	Initial speed no., 0 to F (hexadecimal)				
		15 to 12	ORIGIN RETURN speed no., 1 to F (hexadecimal)				
m + 1	m + 101	03 to 00	ORIGIN SEARCH proximity speed no., 1 to F (hexadecimal)				
		07 to 04	ORIGIN SEARCH high speed no., 1 to F (hexadecimal)				
		11 to 08	LOW-SPEED JOG speed no., 1 to F (hexadecimal)				
		15 to 12	HIGH-SPEED JOG speed no., 1 to F (hexadecimal)				
m + 2	m + 102	05 to 00	Origin compensation value, 0000 to 9999 (BCD)				
m + 3	m + 103	00	Origin compensation direction digit (0: CW; 1: CCW)				
		03 to 01	Not used				
		04	Speed unit multiplication 0: multiplies speed unit by 1 (if m+97: 0) or 10 (if m+97: 1) 1: multiplies speed unit by 1 (if m+97: 0) or 100 (if m+97: 1)				
		07 to 05	Not used				
		11 to 08	ORIGIN SEARCH dwell time, 0 to F (hexadecimal), in units of 0.1 s				
		15 to 12	ORIGIN RETURN dwell time 0 to F (hexadecimal), in units of 0.1 s				
m + 4	m + 104	15 to 00	Backlash compensation value, 0000 to 9999 (BCD)				
m + 5	m + 105	15 to 00	Internally set value of CW limit <div style="text-align: center;"> </div>				
m + 6	m + 106	11 to 00	Internally set value of CW limit <div style="text-align: center;"> </div>				
		15 to 12	Not used				
m + 7	m + 107	15 to 00	Internally set value of CCW limit <div style="text-align: center;"> </div>				
m + 8	m + 108	11 to 00	Internally set value of CCW limit <div style="text-align: center;"> </div>				
		15 to 12	Not used				
m + 9	m + 109	15 to 00	Zone 0: CW side <div style="text-align: center;"> </div>				
m + 10	m + 110	15 to 00	Zone 0: CW side <div style="text-align: center;"> </div> <div style="margin-left: 20px;"> <table border="1" style="border-collapse: collapse;"> <tr> <td style="padding: 2px;">0</td> <td style="padding: 2px;">CW</td> </tr> <tr> <td style="padding: 2px;">1</td> <td style="padding: 2px;">CCW</td> </tr> </table> </div>	0	CW	1	CCW
0	CW						
1	CCW						

Word		Bit	Function
X axis	Y axis		
m + 11	m + 111	15 to 00	Zone 0: CCW side
m + 12	m + 112		(7 digits BCD with direction digit)
m + 13	m + 113	15 to 00	Zone 1: CW side
m + 14	m + 114		(7 digits BCD with direction digit)
m + 15	m + 115	15 to 00	Zone 1: CCW side
m + 16	m + 116		(7 digits BCD with direction digit)
m + 17	m + 117	15 to 00	Zone 2: CW side
m + 18	m + 118		(7 digits BCD with direction digit)
m + 19	m + 119	15 to 00	Zone 2: CCW side
m + 20	m + 120		(7 digits BCD with direction digit)

Word		Bit	Function																					
X axis	Y axis																							
m + 21	m + 121	00	1	CCW																				
			0	CW																				
		01	1	Proximity present																				
			0	No proximity (This setting is invalid in modes 1, 2, and 3.)																				
		02	1	N.O. contact point (\overline{F})																				
			0	N.C. contact point (\overline{V})																				
		03	1	N.O. contact point (\overline{F})																				
			0	N.C. contact point (\overline{V})																				
04	1	Proximity reverse present																						
	0	No proximity reverse																						
15 to 05		Not used																						
m + 22	m + 122	03 to 00	Completion code 0: Single 3: Bank end 1: Pause 4: Extended 2: Continuous 5: Ext. with positioning		Positioning action #0 (Transfer data #0)																			
			07 to 04 Dwell time 0 to F (hexadecimal) in units of 0.1 s																					
			11 to 08 Output code 0 to F (hexadecimal)																					
			15 to 12 Target speed no. 1 to F (hexadecimal)																					
m + 23	m + 123	15 to 00	Target position (pulses) <div style="text-align: center; margin-top: 10px;"> </div>																					
m + 24	m + 124	15 to 00	<table border="1" style="width: 100%; border-collapse: collapse; text-align: center;"> <tr> <td>0</td><td>CW</td><td rowspan="2">Absolute</td><td rowspan="4">Single-axis completion point</td><td>0</td><td>CW</td><td rowspan="4">Interpolation completion point</td> </tr> <tr> <td>1</td><td>CCW</td><td>1</td><td>CCW</td> </tr> <tr> <td>2</td><td>CW</td><td rowspan="2">Incremental</td><td>2</td><td>CW</td> </tr> <tr> <td>3</td><td>CCW</td><td>3</td><td>CCW</td> </tr> </table>		0	CW	Absolute	Single-axis completion point	0	CW	Interpolation completion point	1	CCW	1	CCW	2	CW	Incremental	2	CW	3	CCW	3	CCW
0	CW	Absolute	Single-axis completion point	0	CW	Interpolation completion point																		
1	CCW			1	CCW																			
2	CW	Incremental		2	CW																			
3	CCW			3	CCW																			
m + 25	m + 125		Data format same as for positioning action #0	Positioning action #1 (Transfer data #1)																				
m + 26	m + 126																							
m + 27	m + 127																							
m + 28	m + 128		Data format same as for positioning action #0	Positioning action #2 (Transfer data #2)																				
m + 29	m + 129																							
m + 30	m + 130																							

Note The “No proximity signal” setting (bit 01 OFF) is effective only in mode 0. In modes 1, 2, and 3, the Unit will operate with the proximity signal even if “No proximity signal.”

Word		Bit	Function	
X axis	Y axis			
m + 31 m + 32 m + 33	m + 131 m + 132 m + 133		Data format same as for positioning action #0	Positioning action #3 (Transfer data #3)
m + 34 m + 35 m + 36	m + 134 m + 135 m + 136		Data format same as for positioning action #0	Positioning action #4 (Transfer data #4)
m + 37 m + 38 m + 39	m + 137 m + 138 m + 139		Data format same as for positioning action #0	Positioning action #5 (Transfer data #5)
m + 40 m + 41 m + 42	m + 140 m + 141 m + 142		Data format same as for positioning action #0	Positioning action #6 (Transfer data #6)
m + 43 m + 44 m + 45	m + 143 m + 144 m + 145		Data format same as for positioning action #0	Positioning action #7 (Transfer data #7)
m + 46 m + 47 m + 48	m + 146 m + 147 m + 148		Data format same as for positioning action #0	Positioning action #8 (Transfer data #8)
m + 49 m + 50 m + 51	m + 149 m + 150 m + 151		Data format same as for positioning action #0	Positioning action #9 (Transfer data #9)
m + 52 m + 53 m + 54	m + 152 m + 153 m + 154		Data format same as for positioning action #0	Positioning action #10 (Transfer data #10)
m + 55 m + 56 m + 57	m + 155 m + 156 m + 157		Data format same as for positioning action #0	Positioning action #11 (Transfer data #11)
m + 58 m + 59 m + 60	m + 158 m + 159 m + 160		Data format same as for positioning action #0	Positioning action #12 (Transfer data #12)
m + 61 m + 62 m + 63	m + 161 m + 162 m + 163		Data format same as for positioning action #0	Positioning action #13 (Transfer data #13)
m + 64 m + 65 m + 66	m + 164 m + 165 m + 166		Data format same as for positioning action #0	Positioning action #14 (Transfer data #14)
m + 67 m + 68 m + 69	m + 167 m + 168 m + 169		Data format same as for positioning action #0	Positioning action #15 (Transfer data #15)
m + 70 m + 71 m + 72	m + 170 m + 171 m + 172		Data format same as for positioning action #0	Positioning action #16 (Transfer data #16)
m + 73 m + 74 m + 75	m + 173 m + 174 m + 175		Data format same as for positioning action #0	Positioning action #17 (Transfer data #17)

Word		Bit	Function	
X axis	Y axis			
m + 76 m + 77 m + 78	m + 176 m + 177 m + 178		Data format same as for positioning action #0	Positioning action #18 (Transfer data #18)
m + 79 m + 80 m + 81	m + 179 m + 180 m + 181		Data format same as for positioning action #0	Positioning action #19 (Transfer data #19)
m + 82	m + 182	15 to 00	Speed #1 0001 to 9999 (BCD)	Transfer data #53
m + 83	m + 183	15 to 00	Speed #2 0001 to 9999 (BCD)	
m + 84	m + 184	15 to 00	Speed #3 0001 to 9999 (BCD)	
m + 85	m + 185	15 to 00	Speed #4 0001 to 9999 (BCD)	Transfer data #54
m + 86	m + 186	15 to 00	Speed #5 0001 to 9999 (BCD)	
m + 87	m + 187	15 to 00	Speed #6 0001 to 9999 (BCD)	
m + 88	m + 188	15 to 00	Speed #7 0001 to 9999 (BCD)	Transfer data #55
m + 89	m + 189	15 to 00	Speed #8 0001 to 9999 (BCD)	
m + 90	m + 190	15 to 00	Speed #9 0001 to 9999 (BCD)	
m + 91	m + 191	15 to 00	Speed #10 0001 to 9999 (BCD)	Transfer data #56
m + 92	m + 192	15 to 00	Speed #11 0001 to 9999 (BCD)	
m + 93	m + 193	15 to 00	Speed #12 0001 to 9999 (BCD)	
m + 94	m + 194	15 to 00	Speed #13 0001 to 9999 (BCD)	Transfer data #57
m + 95	m + 195	15 to 00	Speed #14 0001 to 9999 (BCD)	
m + 96	m + 196	15 to 00	Speed #15 0001 to 9999 (BCD)	

Word		Bit	Function									
X axis	Y axis											
m + 97	m + 197	00	Not used	DM word m+3(X)/m+103(Y) bit 04: 0 <table border="1" style="margin: 5px;"> <tr><td>0</td><td>x 1 pps</td></tr> <tr><td>1</td><td>x 10 pps</td></tr> </table> DM word m+3(X)/m+103(Y) bit 04: 1 <table border="1" style="margin: 5px;"> <tr><td>0</td><td>x 1 pps</td></tr> <tr><td>1</td><td>x 100 pps</td></tr> </table>	0	x 1 pps	1	x 10 pps	0	x 1 pps	1	x 100 pps
		0	x 1 pps									
		1	x 10 pps									
		0	x 1 pps									
		1	x 100 pps									
		01	Unit for speed #1									
		02	Unit for speed #2									
		03	Unit for speed #3									
		04	Unit for speed #4									
		05	Unit for speed #5									
		06	Unit for speed #6									
		07	Unit for speed #7									
		08	Unit for speed #8									
		09	Unit for speed #9									
		10	Unit for speed #10									
11	Unit for speed #11											
12	Unit for speed #12											
13	Unit for speed #13											
14	Unit for speed #14											
15	Unit for speed #15											
m + 98	m + 198	15 to 00	Acceleration data (speed incremented in ms)	2 to 2,000 (BCD) <table border="1" style="margin: 5px;"> <tr> <td>x10³</td> <td>x10²</td> <td>x10¹</td> <td>x10⁰</td> </tr> </table>	x10 ³	x10 ²	x10 ¹	x10 ⁰				
x10 ³	x10 ²	x10 ¹	x10 ⁰									
m + 99	m + 199	15 to 00	Deceleration data (speed decremented in ms)	2 to 2,000 (BCD) <table border="1" style="margin: 5px;"> <tr> <td>x10³</td> <td>x10²</td> <td>x10¹</td> <td>x10⁰</td> </tr> </table>	x10 ³	x10 ²	x10 ¹	x10 ⁰				
x10 ³	x10 ²	x10 ¹	x10 ⁰									

Expanded DM Area (If Used)

Word		Bit	Function	
X axis	Y axis			
I I + 1 I + 2	I + 100 I + 101 I + 102		Data format same as for positioning action #0	Positioning action #20 (Transfer data #20)
I + 3 I + 4 I + 5	I + 103 I + 104 I + 105		Data format same as for positioning action #0	Positioning action #21 (Transfer data #21)
I + 6 I + 7 I + 8	I + 106 I + 107 I + 108		Data format same as for positioning action #0	Positioning action #22 (Transfer data #22)
I + 9 I + 10 I + 11	I + 109 I + 110 I + 111		Data format same as for positioning action #0	Positioning action #23 (Transfer data #23)
I + 12 I + 13 I + 14	I + 112 I + 113 I + 114		Data format same as for positioning action #0	Positioning action #24 (Transfer data #24)
I + 15 I + 16 I + 17	I + 115 I + 116 I + 117		Data format same as for positioning action #0	Positioning action #25 (Transfer data #25)
I + 18 I + 19 I + 20	I + 118 I + 119 I + 120		Data format same as for positioning action #0	Positioning action #26 (Transfer data #26)
I + 21 I + 22 I + 23	I + 121 I + 122 I + 123		Data format same as for positioning action #0	Positioning action #27 (Transfer data #27)
I + 24 I + 25 I + 26	I + 124 I + 125 I + 126		Data format same as for positioning action #0	Positioning action #28 (Transfer data #28)
I + 27 I + 28 I + 29	I + 127 I + 128 I + 129		Data format same as for positioning action #0	Positioning action #29 (Transfer data #29)
I + 30 I + 31 I + 32	I + 130 I + 131 I + 132		Data format same as for positioning action #0	Positioning action #30 (Transfer data #30)
I + 33 I + 34 I + 35	I + 133 I + 134 I + 135		Data format same as for positioning action #0	Positioning action #31 (Transfer data #31)
I + 36 I + 37 I + 38	I + 136 I + 137 I + 138		Data format same as for positioning action #0	Positioning action #32 (Transfer data #32)
I + 39 I + 40 I + 41	I + 139 I + 140 I + 141		Data format same as for positioning action #0	Positioning action #33 (Transfer data #33)
I + 42 I + 43 I + 44	I + 142 I + 143 I + 144		Data format same as for positioning action #0	Positioning action #34 (Transfer data #34)

Expanded DM Area Continued

Word		Bit	Function	
X axis	Y axis			
I + 45 I + 46 I + 47	I + 145 I + 146 I + 147		Data format same as for positioning action #0	Positioning action #35 (Transfer data #35)
I + 48 I + 49 I + 50	I + 148 I + 149 I + 150		Data format same as for positioning action #0	Positioning action #36 (Transfer data #36)
I + 51 I + 52 I + 53	I + 151 I + 152 I + 153		Data format same as for positioning action #0	Positioning action #37 (Transfer data #37)
I + 54 I + 55 I + 56	I + 154 I + 155 I + 156		Data format same as for positioning action #0	Positioning action #38 (Transfer data #38)
I + 57 I + 58 I + 59	I + 157 I + 158 I + 159		Data format same as for positioning action #0	Positioning action #39 (Transfer data #39)
I + 60 I + 61 I + 62	I + 160 I + 161 I + 162		Data format same as for positioning action #0	Positioning action #40 (Transfer data #40)
I + 63 I + 64 I + 65	I + 163 I + 164 I + 165		Data format same as for positioning action #0	Positioning action #41 (Transfer data #41)
I + 66 I + 67 I + 68	I + 166 I + 167 I + 168		Data format same as for positioning action #0	Positioning action #42 (Transfer data #42)
I + 69 I + 70 I + 71	I + 169 I + 170 I + 171		Data format same as for positioning action #0	Positioning action #43 (Transfer data #43)
I + 72 I + 73 I + 74	I + 172 I + 173 I + 174		Data format same as for positioning action #0	Positioning action #44 (Transfer data #44)
I + 75 I + 76 I + 77	I + 175 I + 176 I + 177		Data format same as for positioning action #0	Positioning action #45 (Transfer data #45)
I + 78 I + 79 I + 80	I + 178 I + 179 I + 180		Data format same as for positioning action #0	Positioning action #46 (Transfer data #46)
I + 81 I + 82 I + 83	I + 181 I + 182 I + 183		Data format same as for positioning action #0	Positioning action #47 (Transfer data #47)
I + 84 I + 85 I + 86	I + 184 I + 185 I + 186		Data format same as for positioning action #0	Positioning action #48 (Transfer data #48)
I + 87 I + 88 I + 89	I + 187 I + 188 I + 189		Data format same as for positioning action #0	Positioning action #49 (Transfer data #49)

Word		Bit	Function	
X axis	Y axis			
I + 90 I + 91 I + 92	I + 190 I + 191 I + 192		Data format same as for positioning action #0	Positioning action #50 (Transfer data #50)
I + 93 I + 94 I + 95	I + 193 I + 194 I + 195		Data format same as for positioning action #0	Positioning action #51 (Transfer data #51)
I + 96 I + 97 I + 98	I + 196 I + 197 I + 198		Data format same as for positioning action #0	Positioning action #52 (Transfer data #52)

Required Minimum DM Area Settings

X-axis

Word	15	00		
m + 00	Origin return speed No. 1-F	Initial speed No. 0-F	Initial position No. 00 to 52	
m + 01	High-speed JOG speed No. 1-F	Low-speed JOG speed No. 1-F	Origin search high-speed No. 1-F	Origin search proximity speed No. 1-F
m + 21	0	0	Origin classification 00-1F	
m + 22 to m + 81	Positioning actions (No.0-19)			
m + 82 to m + 96	Speeds #1 to #15, for speed numbers designated in words DM m + 00 and DM m + 01.			
m + 98	Acceleration data			
m + 99	Deceleration data			

Y-axis

Word	15	00		
m + 100	Origin return speed No. 1-F	Initial speed No. 0-F	Initial position No. 00 to 52	
m + 101	High-speed JOG speed No. 1-F	Low-speed JOG speed No. 1-F	Origin search high-speed No. 1-F	Origin search proximity speed No. 1-F
m + 121	0	0	Origin classification 00-1F	
m + 122 to m + 181	Positioning actions (No.0-19)			
m + 182 to m + 196	Speeds #1 to #15, for speed numbers designated in words DM m + 100 and DM m + 101.			
m + 198	Acceleration data			
m + 199	Deceleration data			

(m = 1000 + 100 x unit number)

The data in the hatched portion is required so that the alarm LED does not flash. (The other data memories are 0.) However, they should be set so that: the High-speed JOG speed is greater than the Low-speed JOG speed, and the ORIGIN SEARCH high speed is greater than the ORIGIN SEARCH low speed.

Refer to Section 9 Programming Examples, Example 1 for an explanation of setting parameters.

Even when only a single axis is used, the hatched data should be set.

If it is not set, the "ALARM" LED will flash, but the axis in use will operate normally.

This data enables manual operation (JOG, INCH). For ORIGIN SEARCH, when the origin classification is set and positioning is carried out, it sets the position data and speed data.

SECTION 4

Commands

4-1	Setting Up Data Memories	68
4-2	Unit Table Creation	95

Section Overview

The Position Control Unit provides fourteen commands to execute automatic and manual positioning actions, define and establish position, transfer data, and handle interrupts and errors. Although the data required for execution is listed under each command, much of this data is used by more than one command. Refer to 3-2 Data Configuration and Allocation for an outline of the structure of Unit data, and to 5-1 IR Area Data Format for format specifications for particular types of data. Applications of most commands are presented in Section 9 Programming Examples.

4-1 Setting Up Data Memories

DM Area Settings

Words 1000 to 1999 of the DM area of the PC are used as data storage areas for the Position Control Unit, storing data such as initial positioning action numbers, initial speed numbers, speed data, acceleration/deceleration data, position data, completion codes, dwell times, and output codes.

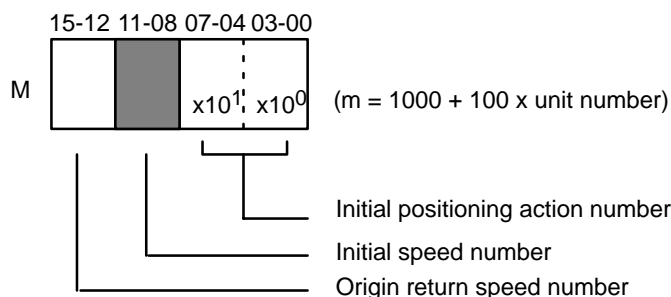

Initial Positioning Action Number

X: Bits 07-00 of DM word m

Y: Bits 07-00 of DM word m+100

Set to a value between 00 and 52 (BCD). This number is used at:

- Initial START after turning on the Unit (if bit 01 of word n is 0)
- START after bank ends
- START after completion of positioning action #19

To use this initial positioning action number in the above situations, set bit 01 of word n to zero. If bit 01 of word n is set to one, the initial positioning action number designated in the IR area is used for the initial START after turning on the Unit, allowing for a different starting point for positioning system initialization. These settings refer to data set in DM words m+21 through m+81/DM words l through l+99.

Initial Speed Number

X: Bits 11-08 of DM word m
 Y: Bits 11-08 of DM word m+100

Set to a value between zero and F (hex). An initial speed number of zero indicates a speed of zero. All the other speed numbers set here refer to the speeds set in DM words m+82 through m+97/bit 04 of DM word m+3.

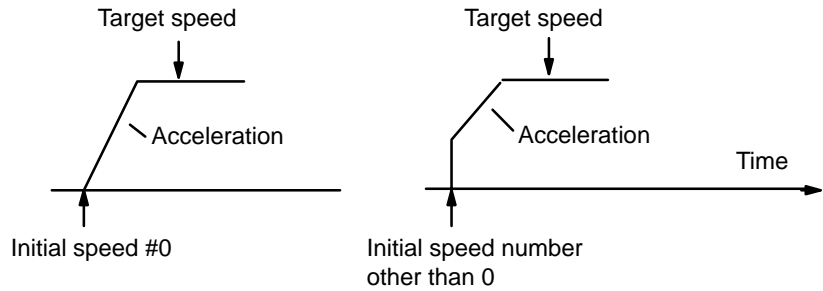

ORIGIN RETURN Speed Number

X: Bits 15-12 of DM word m
 Y: Bits 15-12 of DM word m+100

ORIGIN RETURN speed number
 Set to an integer between 0 and F (hex).

This is the speed used to return to an already-searched origin

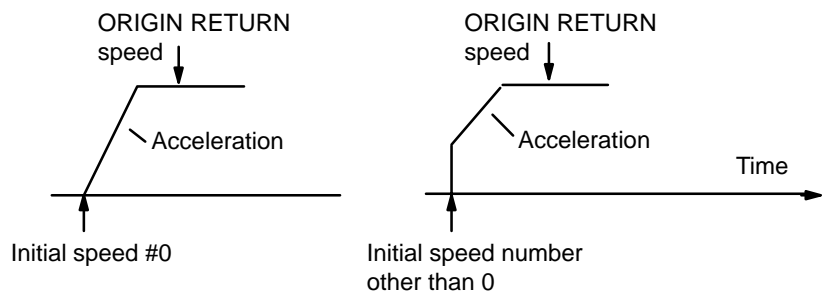

ORIGIN SEARCH Proximity Speed Number (Low Speed)

X: Bits 03-00 of DM word m+1
 Y: Bits 03-00 of DM word m+101

ORIGIN SEARCH proximity speed number
 Set to an integer between 1 and F (hex).

- The speed number set here refers to one of the speeds set in DM words m+82-m+97/ Bit 04 of DM word m+3.
- It cannot be set higher than the ORIGIN SEARCH high speed number.
- If there is no origin proximity signal, the speed designated here is used for the entire ORIGIN SEARCH operation.

**ORIGIN SEARCH
High Speed Number**

X: Bits 07-04 of DM word m+1
Y: Bits 07-04 of DM word m+101

ORIGIN SEARCH high speed number
Set to an integer between 1 and F (hex).

- The speed number set here refers to one of the speeds set in DM words m+82-m+97/Bit 04 of DM word m+3.
- The speed designated here is used only if an origin proximity signal is present.

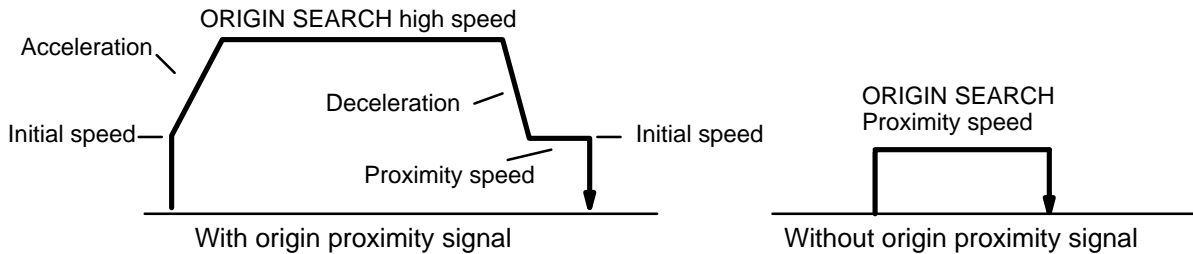
**LOW-SPEED JOG Speed
Number**

X: Bits 11-08 of DM word m+1
Y: Bits 11-08 of DM word m+101

LOW-SPEED JOG: set to an integer between 1 and F (hex).

- It cannot be set higher than the HIGH-SPEED JOG number.
- The speed number set here refers to one of the speeds set in DM words m+82 to m+97 (Bit 4 of word m+3)

**HIGH-SPEED JOG Speed
Number**

X: Bits 15-12 of DM word m+1
Y: Bits 15-12 of DM word m+101

HIGH-SPEED JOG: set to an integer between 1 and F (hex).

- The speed number set here refers to one of the speeds set in DM words m+82 to m+97 (Bit 4 of word m+3)

Origin Compensation

If the position determined by origin signal input is to be treated as the origin (position 0), set word m+2 to 0. If there is an origin compensation value set in word m+3, then, after the position determined by origin signal input is reached, compensation will be executed at proximity speed in the direction set in bit 00 of word m+3.

In the example of origin compensation diagrammed below, bit 00 of word m+3 is set at 1, so origin compensation is counterclockwise.

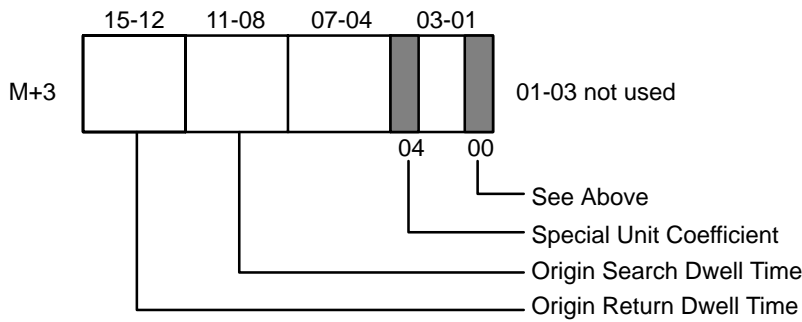
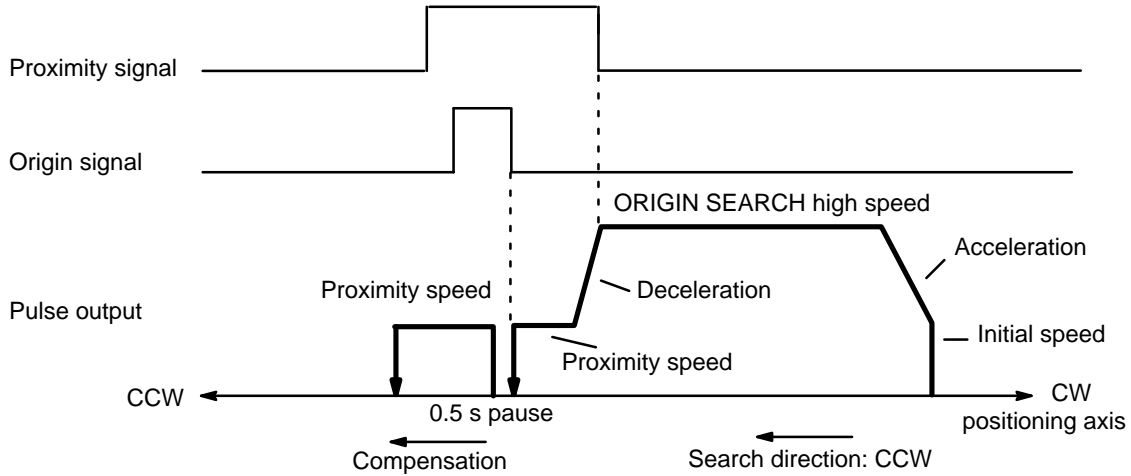

Speed Coefficient

X: Bit 04 of DM word m+82-m+97/DM word m+3
 Y: Bit 04 of DM word m+182-m+197/DM word m+103

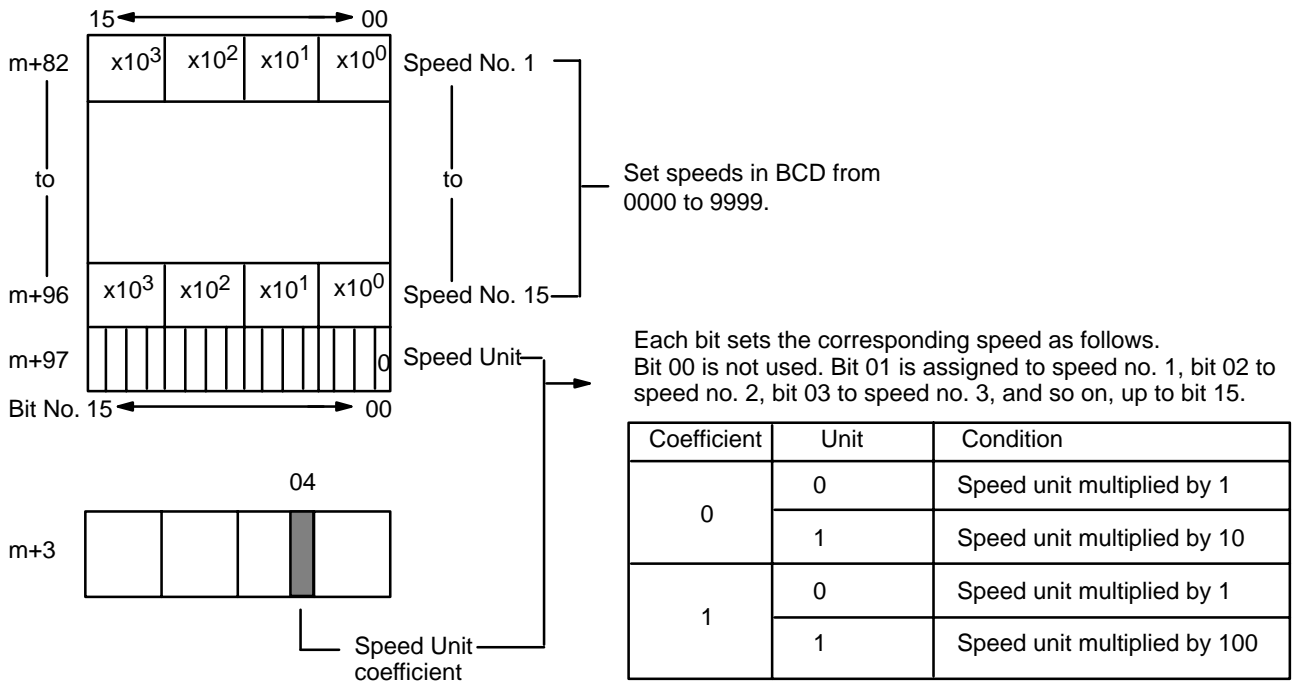

Bit 00 of DM word m+97 is not used. Bits 01-15 contain the speed units for speed numbers 1-15.

ORIGIN SEARCH Dwell Time

X: Bits 11-08 of DM word m+3
 Y: Bits 11-08 of DM word m+103

Set to an integer between 0 and F (hex) in units of 0.1 seconds. After the ORIGIN SEARCH has ended and the dwell time elapsed, the busy flag turns OFF and the next action is enabled.

ORIGIN RETURN Dwell Time

X: Bits 15-12 of DM word m+3
 Y: Bits 15-12 of DM word m+103

Set to an integer between 0 and F (hex) in units of 0.1 seconds. After the ORIGIN RETURN has ended and the dwell time elapsed, the busy flag turns OFF and the next action is enabled.

Backlash Compensation

Backlash compensation can be used to compensate for the amount of mechanical play present in gears, particularly when the direction of positioning actions changes.

Note This explanation relates to the X axis, but the same format is used for the Y axis. There is only one parameter that needs to be set to compensate for backlash.

Using Backlash Compensation

Backlash compensation can correct the sort of mechanical interlocking error shown in the illustration.

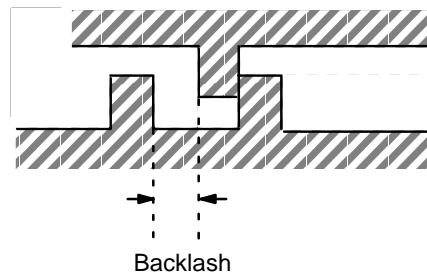

When the CW and CCW directions are reversed, the number of pulses set in the data memory are output at the rate corresponding to the initial speed, then normal control proceeds.

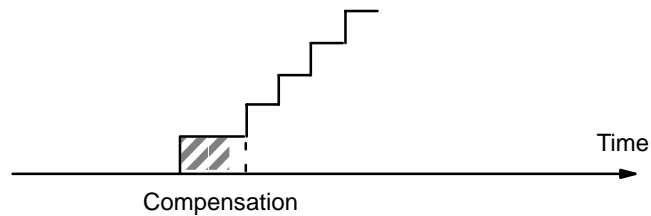

If STOP is executed during backlash compensation for any operations requiring acceleration or deceleration (HIGH-SPEED JOG, ORIGIN SEARCH, ORIGIN RETURN, and START), the Unit will stop feeding immediately after outputting the initial step of the acceleration or deceleration, which will include the backlash compensation set above.

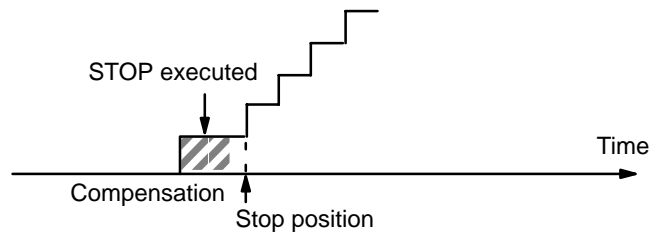

Note This explanation is made with respect to the X axis: case of the Y axis is essentially the same. Backlash compensation is not performed if the origin is undefined.

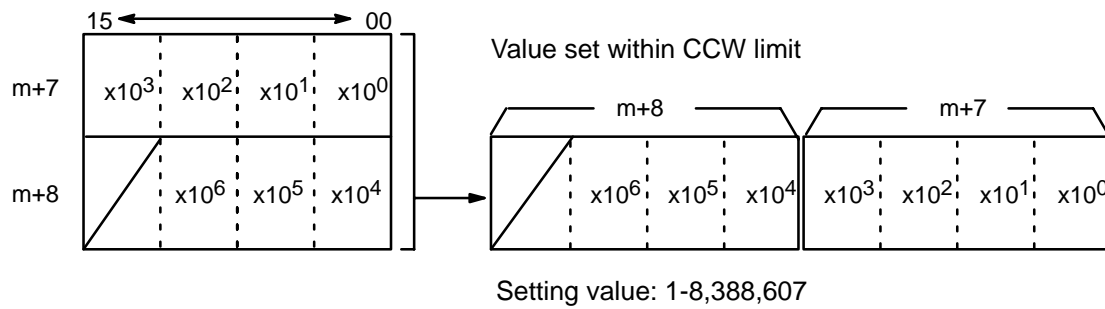
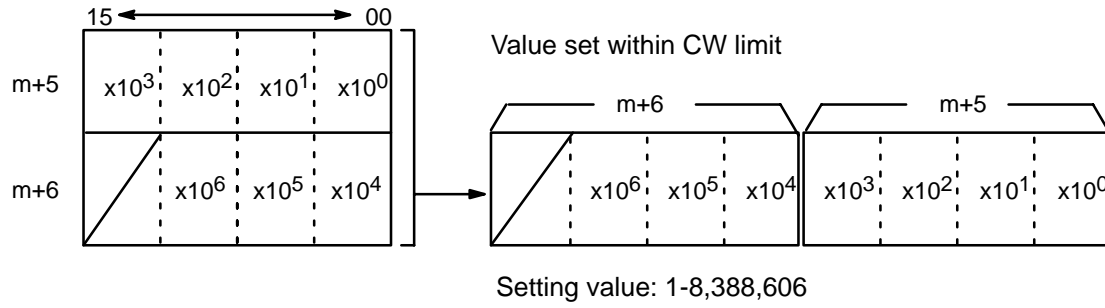

When the setting value is 0, the limits are automatically set to:

- CW = 8,388,607
- CCW = 8,388,608.

Internal CW/CCW Limits

Limits on the CW and CCW sides of the origin can be set internally to restrict Unit operation to within these limits.

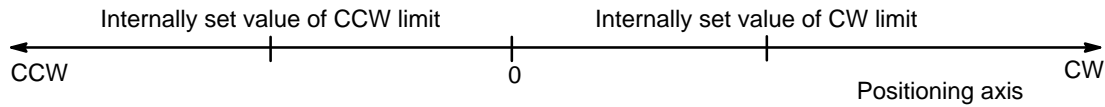
**Internal CW Limit**

X: Words m+6 to m+5
Y: Word m+106 to m+105

Internal CCW Limit

X: Words m+8 to m+7
Y: Word m+108 to m+107

Operation**Positioning Actions**

If either of these limits is reached during execution of positioning actions, pulse output will stop, and an error code, either 5030 or 5031, will be generated.

Manual Operation

If either of these limits is reached during execution of LOW-SPEED JOG, HIGH-SPEED JOG, or INCH, pulse output will stop, and an error code, either 5070 or 5071, will be generated.

Note When X axis and Y axis START are initiated simultaneously, X axis START receives priority. Since X axis processing takes 10-50 ms, Y axis START is delayed by this period.

START will not occur during STOP even if the START command is given.

If an interpolation START command is initiated for the X or Y axis during STOP, START will not occur and the command will be ignored.

Zones

Up to three zones can be set in the DM area. If one or more zones have been set, zone flags in the IR area can be used to determine if the present position is within any established zones. A zone flag is ON (1) when the present position is within the zone; OFF (0) when it is not. Zones can be set to cover a wide range of positions or narrowed to cover only part of a single positioning action. Zones can also be set to overlap, if target. For application example, see programming Example 8 in Section 9. This explanation is made with respect to the X-axis. The case of the Y axis is essentially the same.

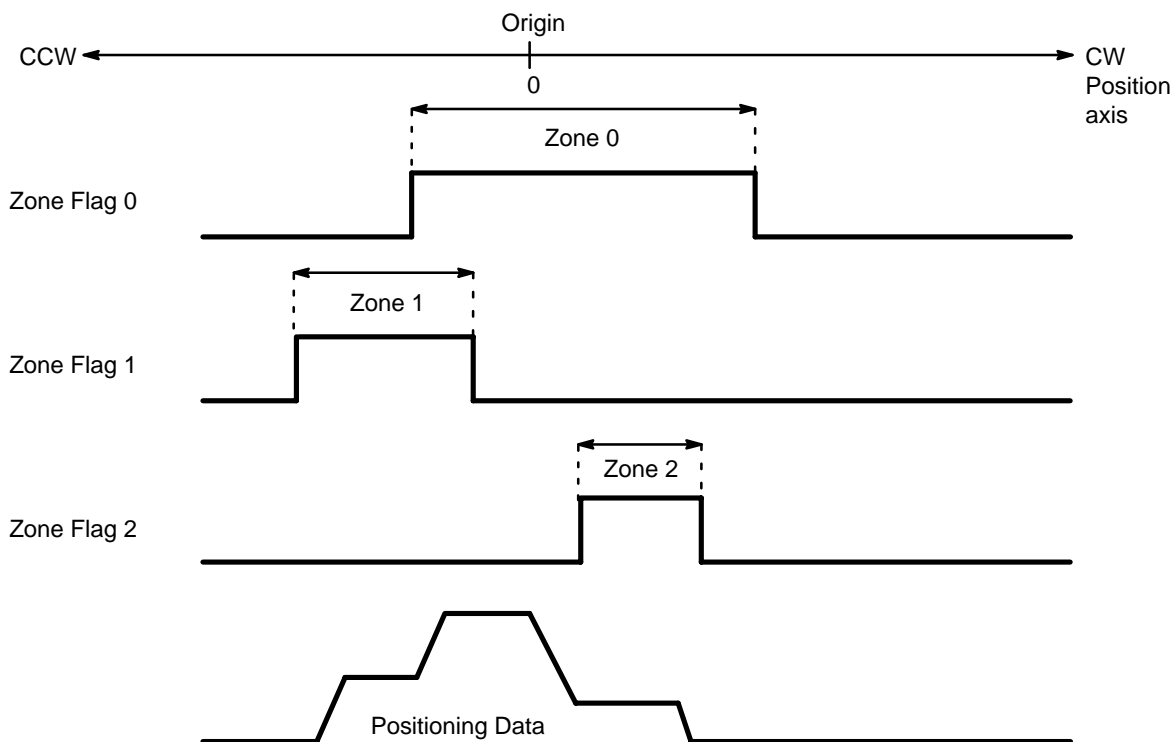

Regions spanning multiple positioning data, or some small regions and the like may be set freely using positioning data and independent regions. Whether the current position lies inside or outside the region is indicated.

Zone Settings

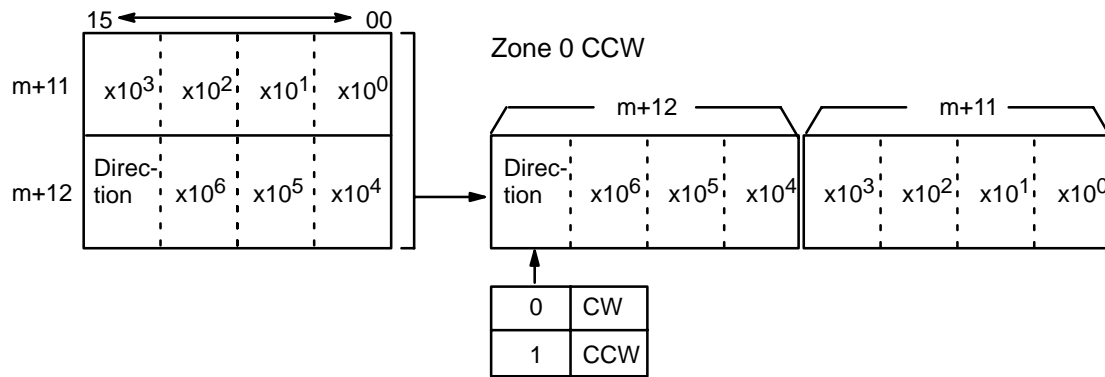
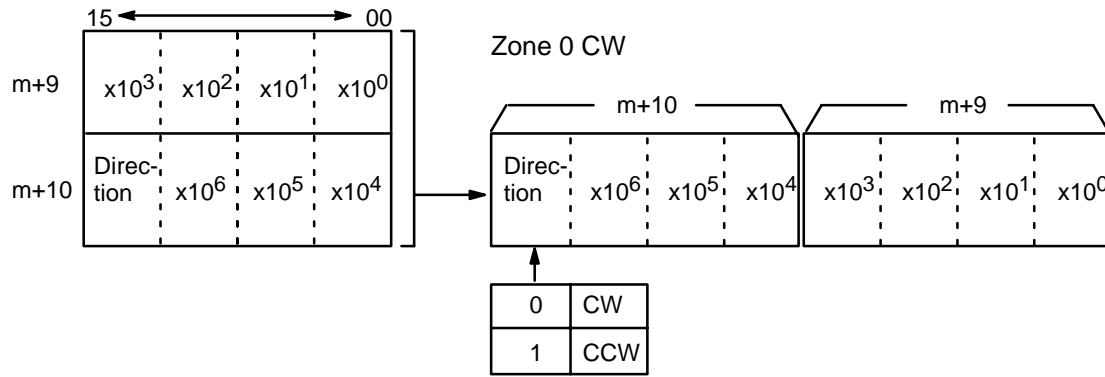

Zones 1 and 2, CW/CCW are set similarly.

m+13 m+14	Zone 1 CW
m+15 m+16	Zone 1 CCW
m+17 m+18	Zone 2 CW
m+19 m+20	Zone 2 CCW

The CW and CCW sides of Zones 0, 1 and 2 form two sets of data. When the values of all four word are 0, it is assumed that there is no zone setting and no decision is executed. When the origin is confirmed and the current position is acquired, this decision is executed.

Origin Signal and Proximity Signal X: DM word m+21
Y: DM word m+121

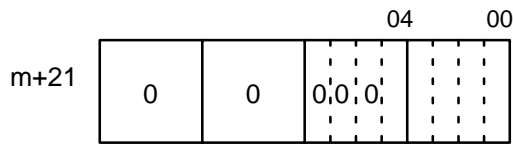
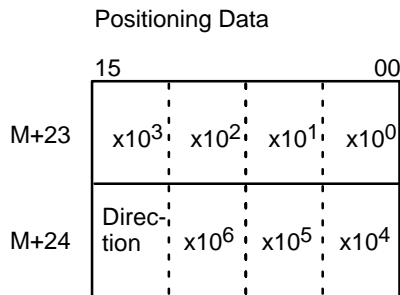
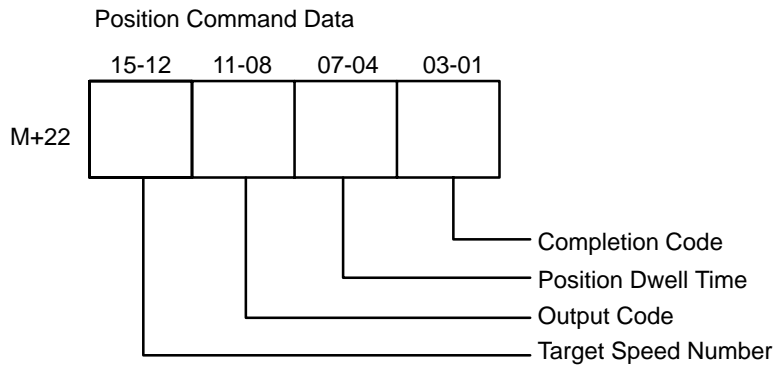

(m=1000 + 100 x unit number)

bit	Designation	1	0
00	ORIGIN SEARCH direction	CCW	CW
01	Origin proximity signal presence	present	absent
02	Origin proximity type	N.O.	N.C.
03	Origin signal type	N.O.	N.C.
04	ORIGIN SEARCH method	present	absent

N.O: Normally-open contacts
N.C: Normally-closed contacts

Positioning Actions

X: DM words $m+22$ through $m+81$ /DM words l through $l+98$
 Y: DM words $m+122$ through $m+181$ /DM words $l+100$ through $l+198$

Positioning actions (or sequences) consist of a completion code, dwell time, output code, speed number, and target position. These actions are generally referred to by number and completion code. For example, “#6, continuous” indicates positioning action #6 with a completion code of 2 (continuous). The settings for positioning action #0, DM words $m+22$ through $m+24$, are explained below. The same procedure is followed for any other positioning action. Refer to Section 3-3 DM Area Allocations for detailed word and bit allocations. If you are using an expanded DM area, set positioning action #s 20-52 in the same way.

Completion Code

X: Bits 03-00 of DM word $m+22$
 Y: Bits 03-00 of DM word $m+122$

Set from 0 to 5 to specify the one of the six types of completions (described below). Also refer to Section 5-4 Execution Examples.

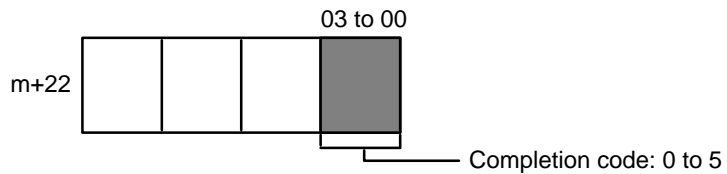

Only codes 0 through 3 can be used with interpolation; codes 4 and 5 cannot be used.

0	Single
1	Pause
2	Continuous
3	Bank
4	Extended
5	Extended with positioning

0: Single

The target position and target speed are reached and feeding stops. After completion of this action, START is required to execute the next positioning action.

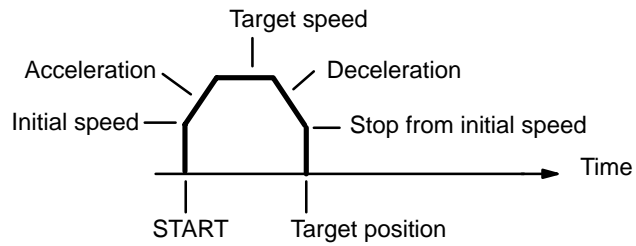

1: Pause

The target position and target speed are reached, and the next positioning action is automatically started following the dwell time.

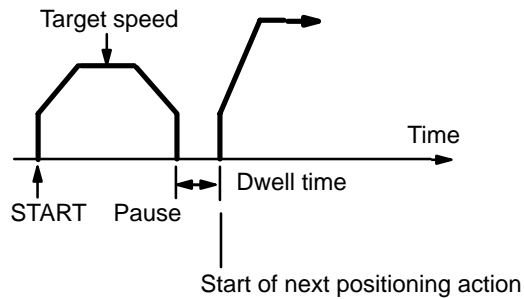

2: Continuous

As soon as the target position for the first positioning action is reached, the next positioning action is started. The first target position is reached at the target speed set for the next positioning action, so that the next positioning action can be executed immediately.

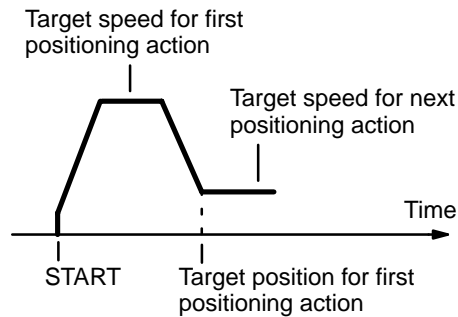

3: Bank end

The term “bank” refers to a combination of several positioning actions or sequences. The target position and target speed are reached and feeding stops. The next positioning action to be executed will be the initial positioning action number in bits 07-00 of DM word m. START is required to resume execution of positioning actions.

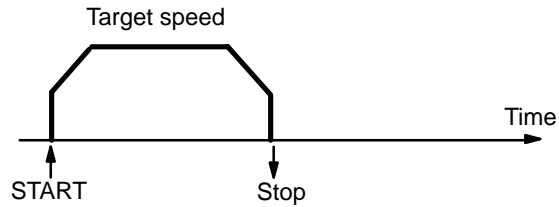

4: Extended

The Unit continually outputs pulses at the speed set for the positioning action. The Unit will not calculate the present position, and the no-origin flag (bit 11 of word n+10) will go ON during operation. The direction of pulse output is determined by the direction digit set in the positioning data. Extended positioning actions are terminated with STOP. START is required to resume execution of positioning actions.

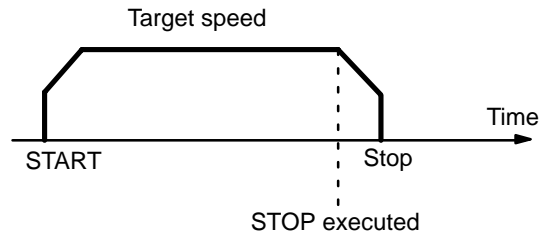

5: Extended With Positioning

The Unit continually outputs pulses at the speed set for the positioning action. The Unit will not calculate the present position, and the no-origin flag (bit 11 of word n+5) will go ON during operation. The direction of pulse output is determined by the direction bit set for the positioning action. When STOP is executed, the present position is reset and positioning is executed according to the data set for the positioning action. START is required in order to resume execution of positioning actions.

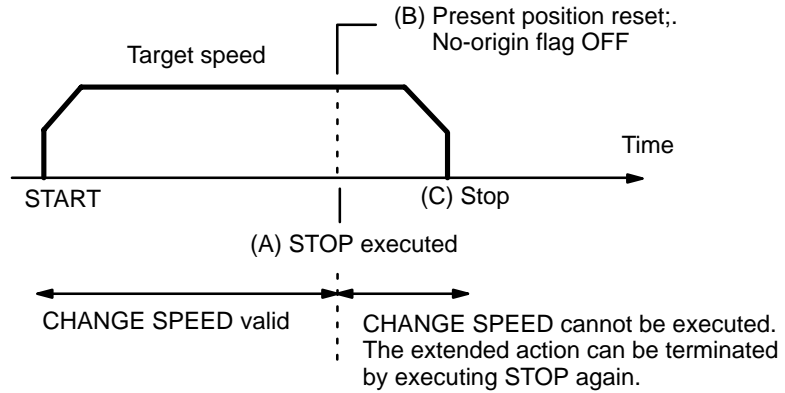

STOP can be executed by either an external input signal or by setting bit 15 of IR word n. For details, refer to Section 5-6 STOP.

Delay Time

From position A to position B in the above diagram, there is a delay time of approximately 2 ms. From position B to position C, there may be a maximum additional delay time of 2 ms. The delay time between points A and B does not affect the present position set in words n+13 and n+14. During the delay time between B and C, the present position in those words is reset to zero and then updated. The delay time is also output to those words.

Positioning Action No. 0 for Unit No.0

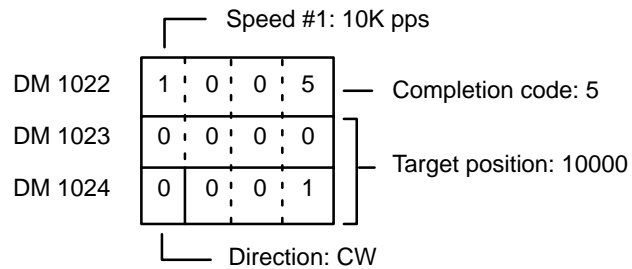

After STOP, the present position is as follows:

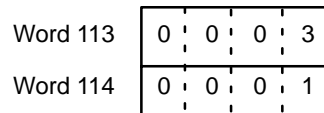

In this example, the present position after operation has stopped is 10003. Since the target position was 10000, the actual position has exceeded the target position by 3 pulses. Since the speed was set to 10K pps, $3/10,000 = 0.003 \text{ s} = 0.3 \text{ ms}$. Thus the delay time is 0.3 ms.

If the target position is near the position at which STOP is executed, pulse output will cease before deceleration is completed. However, no error code will be output. Also remember that the next START cannot be executed while the STOP command bit is set to one.

Dwell Time

X: Bits 07-04 of DM word m+22
 Y: Bits 07-04 of DM word m+122

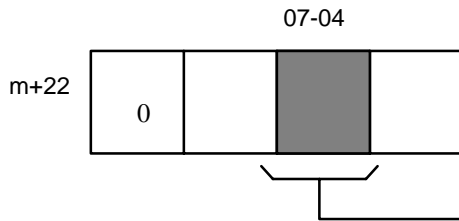

ORIGIN SEARCH dwell time
 Set to an integer between 0 and F (hex) in units of 0.1 seconds. After pulse output stops and the dwell time has elapsed, the busy flag turns OFF and the next action is enabled.

The next action can be executed when the busy flag turns OFF after the dwell time has expired. In other words, the positioning completed flag remains OFF and the busy flag remains ON until the dwell time has expired. (Refer to Section 5-4 Execution Examples.)

Output Code

X: Bits 11-08 of DM word m+22
 Y: Bits 11-08 of DM word m+122
 Set to an integer between 0-F (hex).

These codes can be set as desired by the user. Upon completion of the positioning action, they are output to bits 11-08 of word n+12 in the OUT refresh area.

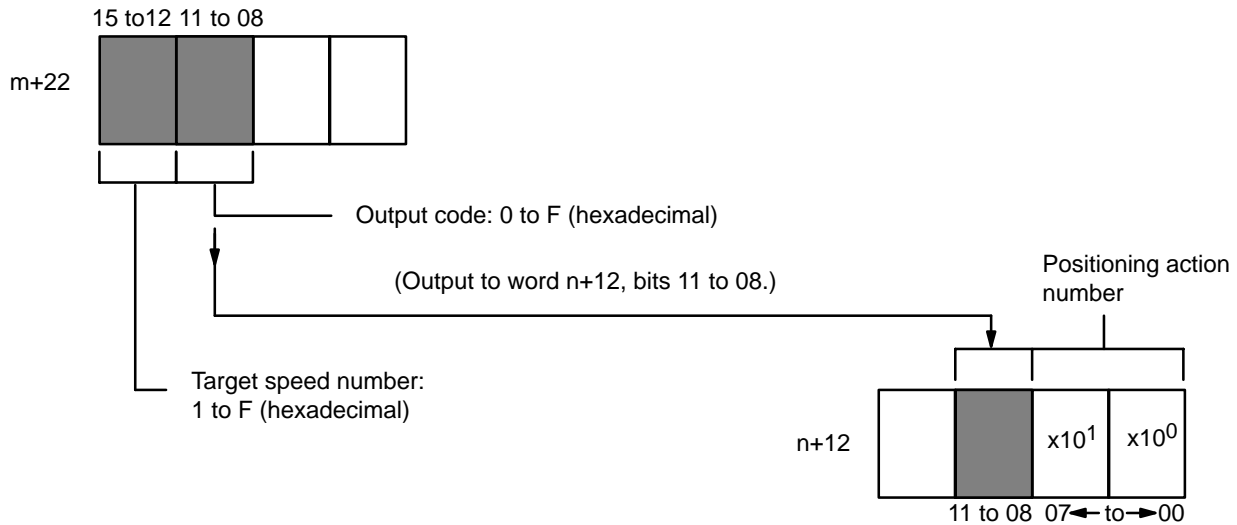

Target Speed Number

X: Bits 15-12 of DM word m+22
 Y: Bits 15-12 of DM word m+122

Set to a value between 1 and F (hex). The speed numbers set here refer to the speeds set in DM words m+82 through m+97/bit 04 of DM word m+3. The speed unit is set in DM word m+97 and bit 04 of word m+3. A speed coefficient is set in bits 05 of word m+2; its setting is explained in Section 6-1 IR Area Settings.

Target Position

X: DM words m+23 and m+24
 Y: DM words m+123 and m+124

The target position is set by the lowest seven digits, i.e., all four digits of word 23 and the lowest three digits of word 24. The remaining digit of word 24 is used as the direction digit. (Refer to Section 3-3 DM Area Allocations.)

Maximum values are as follows:

CW: 8388606 pulses

CCW: 8388607 pulses

Absolute values are measured from the origin. Increment values are measured from the present position. Positions resulting from increments must be between -8,388,607 and +8,388,606.

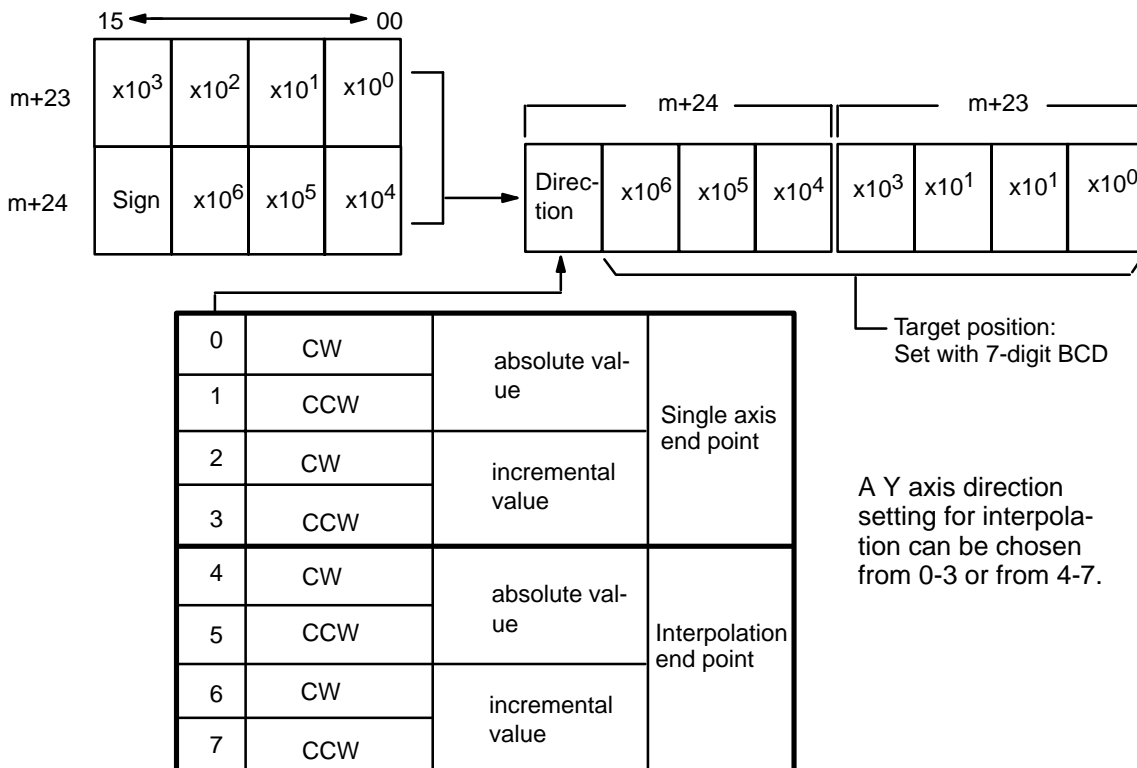

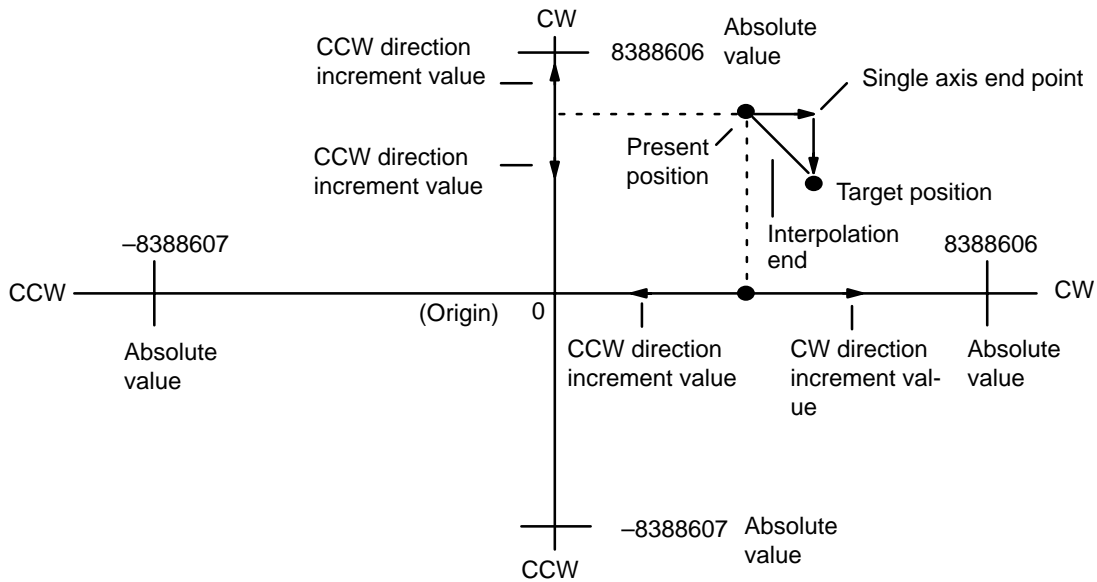

Absolute value expresses a displacement from the origin. Increment value expresses a displacement from the present position. When set for single-axis completion, the X and Y axes operate separately. When interpolated completion is set, linear positioning between the present position and target position is carried out. The result of adding an increment value to the present position must be positive for CW movement and negative for CCW movement.

Note that the TEACH command can be used to write target positions into the DM area. Refer to Section 7 TEACH for details.

Interpolation Settings

When setting an interpolation end point, choose a direction setting from four and seven for the target position, and set the same positioning action number for the X and Y axes. Interpolation begins when the X axis START command bit (bit 00 of word n) turns ON. The positioning action number executed for X axis will also be executed for the Y axis. If Y axis START command bit (bit 00 of word n+5) is ON, nothing will be executed except independent Y axis operation. Execution is carried out with the initial positioning action number, initial speed number, acceleration, deceleration, target speed number, output code, and dwell time set for the X axis.

During interpolation, completion code 2 (Continuous) cannot be used with single-axis operation and completion code 3 (Bank end) cannot be used for the X axis only. When X-axis completion is set to code 2 or 3, the Y-axis completion code will also become code 2 or 3, with the completion code setting for the Y axis being ignored. Interpolation with completion codes 4 (Extended) and 5 (Extended with positioning) is also not carried out.

Cautions for Using Completion Code 2: Continuous

1. Stepping Motor

Avoid using continuous completion, code 2, with the stepping motor. During interpolation, pulses are output in accordance with the speed changes set for the interpolation and the programmed trajectory. When interpolation is executed continuously, changes in speed for the X and Y axes cause pulses to be output rapidly, and to be stopped suddenly. If the stepping motor does not follow these changes in speed, misadjustment occurs. Consequently, it is prudent to use completion code 2 (Continuous) as little as possible with the stepping motor. Instead, use completion code 1 (Pause).

Interpolation operation

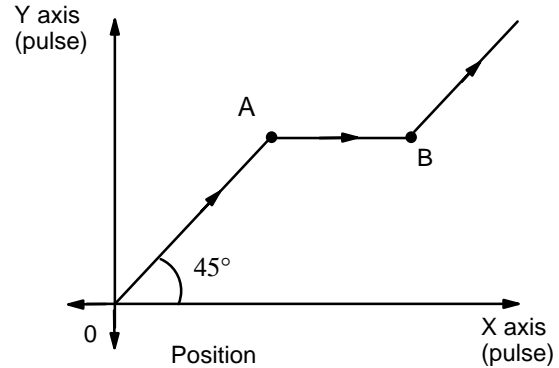
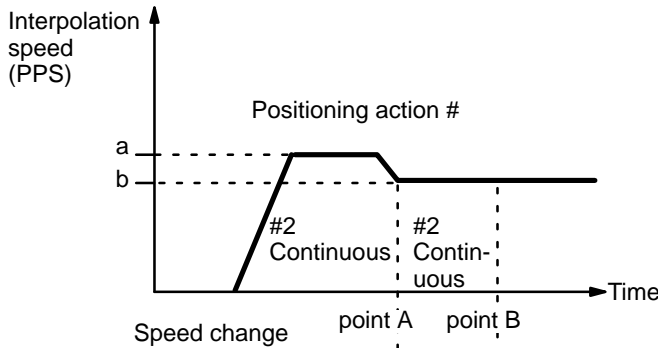

X axis speed change

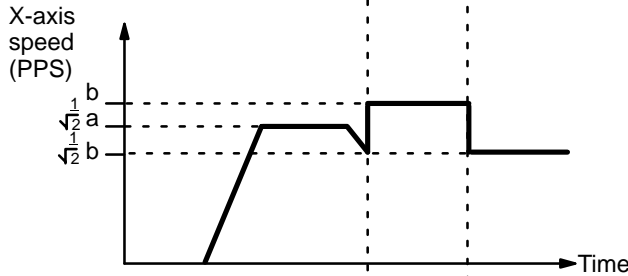

Y axis speed change

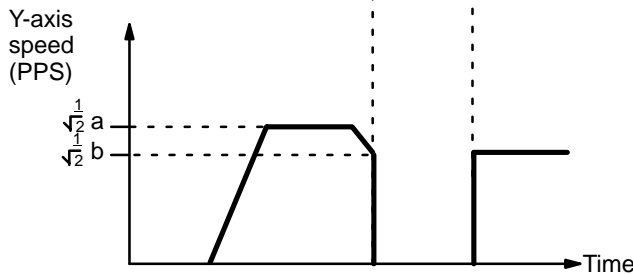

2. Programs

During continuous operation, direction cannot be reversed until completion of the positioning action. The following examples illustrate operations that cannot be carried out, because the X axis positioning actions No. 1 and No. 3, and the Y axis positioning actions No. 0 and No. 2, are in the opposite directions. Instead of continuous completion, use completion code 1 (Pause) for positioning action No. 1, or for all the positioning actions.

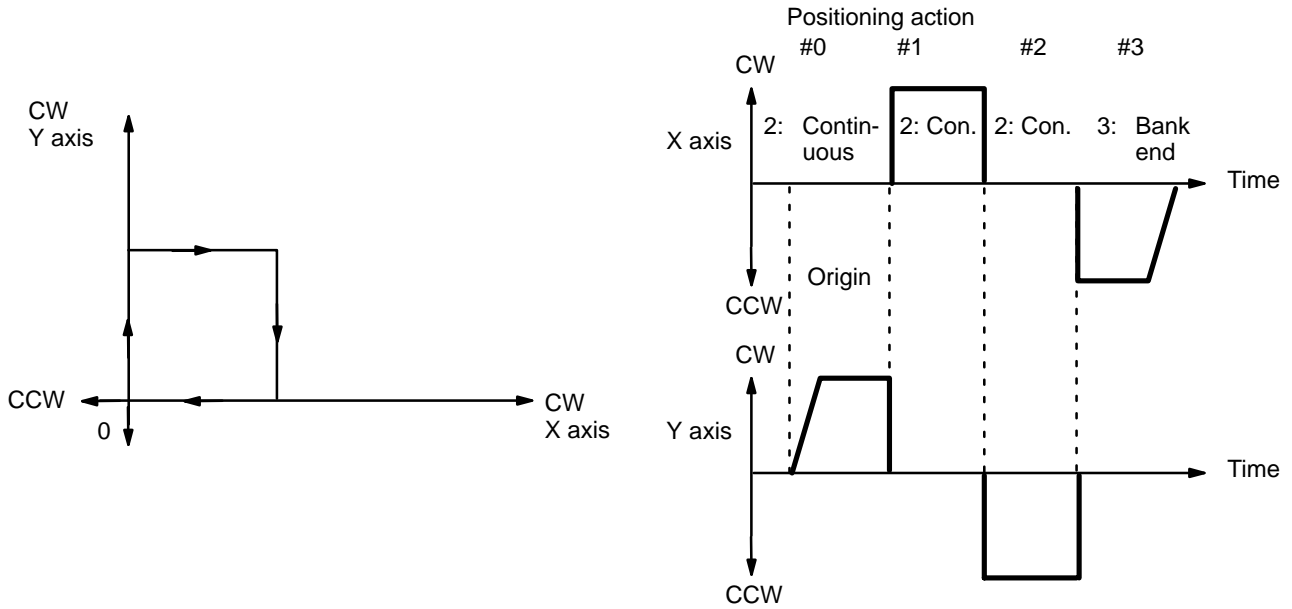

3. Pulse Displacement

Pulse displacement can occur at continuous transition points.

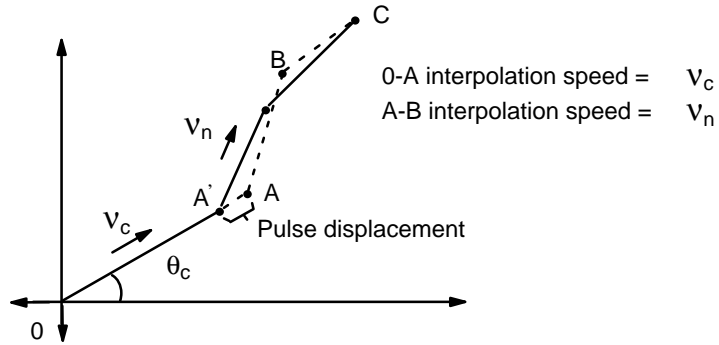

The amount depends on the settings of the program, but pulse displacement invariably occurs when continuous completion is used with interpolation.

The maximum pulse displacement vector is $\frac{V_n}{250}$,

so displacement in the X direction is between 0 and $\frac{V_n}{250} \cos \theta_c$,

and displacement in the Y direction is between 0 and $\frac{V_n}{250} \sin \theta_c$.

Displacement occurs because acceleration/deceleration patterns for interpolation receive priority. During continuous positioning there is no displacement at the final point (C in the diagram above), so positioning can be executed accurately at that point. For accurate positioning at intermediate points, use completion code 1 (Pause).

Speeds

Slight differences exist between speeds set in the DM area and actual speeds. These differences do not affect positioning accuracy.

m+82	m+182	15 to 00	Speed #1	0000 to 9999 (BCD)
m+83	m+183	15 to 00	Speed #2	0000 to 9999 (BCD)
m+84	m+184	15 to 00	Speed #3	0000 to 9999 (BCD)
m+85	m+185	15 to 00	Speed #4	0000 to 9999 (BCD)
m+86	m+186	15 to 00	Speed #5	0000 to 9999 (BCD)
m+87	m+187	15 to 00	Speed #6	0000 to 9999 (BCD)
m+88	m+188	15 to 00	Speed #7	0000 to 9999 (BCD)
m+89	m+189	15 to 00	Speed #8	0000 to 9999 (BCD)
m+90	m+190	15 to 00	Speed #9	0000 to 9999 (BCD)
m+91	m+191	15 to 00	Speed #10	0000 to 9999 (BCD)
m+92	m+192	15 to 00	Speed #11	0000 to 9999 (BCD)
m+93	m+193	15 to 00	Speed #12	0000 to 9999 (BCD)
m+94	m+194	15 to 00	Speed #13	0000 to 9999 (BCD)
m+95	m+195	15 to 00	Speed #14	0000 to 9999 (BCD)
m+96	m+196	15 to 00	Speed #15	0000 to 9999 (BCD)

Settings between 92 and 250,000 pps

$$\text{Actual speed (pps)} = \frac{6,000,000}{\text{INT}(6,000,000/\text{set value})}$$

where,

INT: Nearest integer

INT(6,000,000/set value): Divider ratio

pps: pulses per second

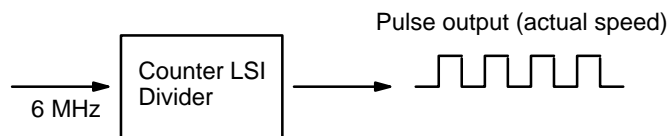

The slight difference occurs because a 6-MHz source clock is divided by the integral divider ratio.

Example Values:

Set Value (pps)	Actual Speed (pps)
250,000	250,000.00
180,000	181818.18
140,000	142,857.14
95,000	95,238.10
3,500	3,500.58
92	92.00

Settings between 1 and 91 pps

$$\text{Actual speed (pps)} = \frac{23,437.5}{\text{INT}(23,437.5/\text{set value})}$$

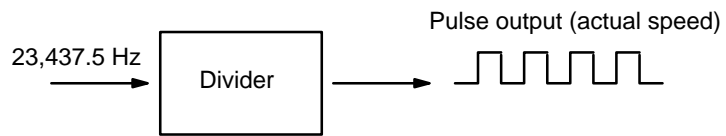

A 23,437.5 Hz source clock is divided by the integral divider ratio.

Example Values:

Set Value (pps)	Actual Speed (pps)
91	91.20
60	60.10

Speed Unit Multiplier

Word		Bit	Function	
X-axis	Y-axis			
m+97	m+197	00	Not used	DM word m+3(X)/m+103(Y) bit 04:0
		01	Unit for speed #1	
		02	Unit for speed #2	
		03	Unit for speed #3	
		04	Unit for speed #4	
		05	Unit for speed #5	
		06	Unit for speed #6	
		07	Unit for speed #7	DM word m+3(X)/m+103(Y) bit 04:1
		08	Unit for speed #8	
		09	Unit for speed #9	
		10	Unit for speed #10	
		11	Unit for speed #11	
		12	Unit for speed #12	
		13	Unit for speed #13	
		14	Unit for speed #14	
		15	Unit for speed #15	

0	x 1 pps
1	x 10 pps

0	x 1 pps
1	x 100 pps

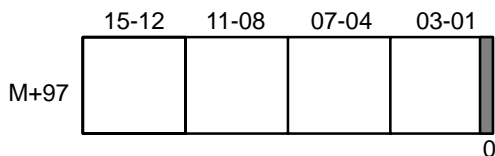

Each bit sets the corresponding speed as follows. Bit 00 is not used.

- Bit 00 is not used
- Bit 01 is assigned to speed no.1
- Bit 02 is assigned to speed no.2
- Bit 03 is assigned to speed no.3
- ...
- Bit 15 is assigned to speed no.15

4-2 Unit Table Creation

The internal processing of the Position Control Unit is as follows during table creation.

- 1, 2, 3...
- The speed difference, ΔV , is obtained to express the range of speed settings.

$$\Delta V = \text{MAX} - \text{MIN}$$
 where,
 MAX: Twice the maximum set value (not to exceed 250,000).
 MIN: Speed indicated by initial speed number.
 - The number of division steps, L, is determined such that the unit time for each step is 4 ms. The maximum number of steps is 250.

$$L = \frac{(\Delta V/R)}{4}$$
 where,
 R: Acceleration or deceleration data, whichever greater.
 $\Delta V/R$: Acceleration (or deceleration) time between MAX and MIN
 - Next, the speed difference (Δv) for each step is obtained.

$$\Delta v = (\Delta V/L)$$
 - The divider ratios for all steps are calculated and set in a table.

Step	Target (step) speed	Division ratio
1	Min	
2	MIN + Δv	
3	MIN + 2 x Δv	
⋮		
L	MAX	

The dividing ratio is an integer value explained on the preceding page.

5. Example:

Start speed	0 (pps)
Maximum value of speed data Nos. 1 to 15	20,000 (pps)
Acceleration	100 (pps/1ms)
Deceleration	100 (pps/1ms)

$$\Delta V = 20000 \times 2 = 40000$$

$$L = \frac{(\Delta V/R)}{4} = \frac{(40000/100)}{4} = 100$$

$$\Delta v = 40000/100 = 400$$

v (Speed)

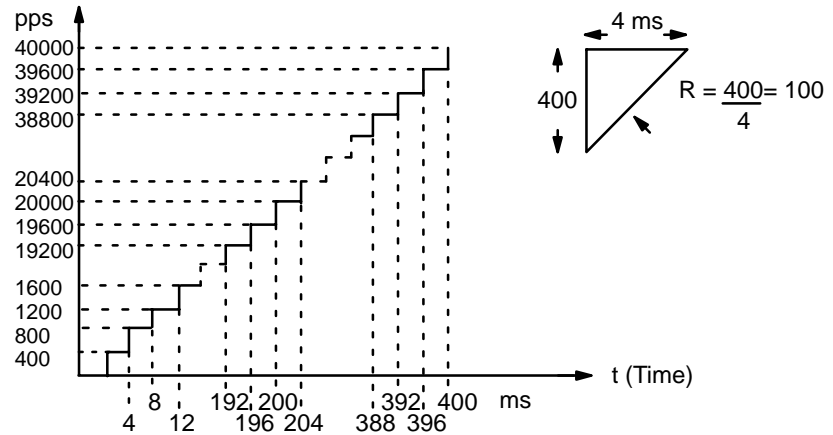

SECTION 5

IR Area Allocation

5-1	IR Area Allocation	98
5-2	IR Area Data Format	100
5-3	IR Area Settings	105
5-4	Execution Examples	106
5-5	ORIGIN SEARCH Completion Examples	119
5-6	Start/Stop	122

Section Overview

This section presents the IR Area allocation and data formats. It also provides some execution examples to illustrate how the Position Control Unit is used in different configurations.

5-1 IR Area Allocation

Here n represents the first IR word allocated to the Unit and equals 100 plus 10 times the unit number. These tables list the X axis allocations. The Y axis allocations are analogous, but are offset 5 words from the X axis locations. For example, bit 00 of word n is the START command bit for the X axis, while bit 00 of word n+5 is the START command bit for the Y axis.

Word	n	n+1	n+2	n+3	n+4	
Bit	00	START	Initial positioning action no. 00-52 (BCD)	Speed coefficients (05 to 00) Deviation counter reset (06) Origin adjustment (07)	Beginning word no. (for TRANSFER DATA)	PC data area (for TRANSFER DATA) 0-4 (BCD)
	01	Valid initial positioning action number				
	02	ORIGIN SEARCH				
	03	ORIGIN RETURN				
	04	RELEASE PROHIBIT				
	05	READ ERROR				
	06	CHANGE SPEED				
	07	Valid speed coefficient	CHANGE SPEED COEFFICIENT			
	08	RESET ORIGIN	TEACH positioning action no. 00-52 (BCD)	Beginning transfer no. 00-58 (BCD)		Number of transfers (for TRANSFER DATA) 01-59 (BCD)
	09	TEACH				
	10	TRANSFER DATA				
	11	HIGH-SPEED JOG				
	12	JOG direction				
	13	LOW SPEED JOG				
	14	INCH	Buffer transfer	TRANSFER DATA type		
15	STOP					

Continued

Word	n+10		n+11	n+12	n+13	n+14
Bit	00	Positioning completed flag	Error code	Positioning action no. 00-52 (BCD)	Present position (rightmost 4 digits)	Direction digit Present position (leftmost 3 digits)
	01	Bank completed flag				
	02	At-origin flag				
	03	Alarm flag				
	04	Emergency stop flag				
	05	Error flag				
	06	Zone 0 flag				
	07	Zone 1 flag		Positioning completed signal		
	08	Zone 2 flag		Output code 0-F		
	09	Teaching completed flag				
	10	Transfer completed flag				
	11	No-origin flag				
	12	Busy flag		Emergency stop signal		
	13	CW limit flag		External interrupt signal		
	14	CCW limit flag		Origin signal		
	15	STOP flag		Origin proximity signal		

5-2 IR Area Data Format

Data is allocated either by bit or by word, though it is often input and output by decimal digit, i.e., four bits (BCD). Position data is held in two adjacent words, generally with a direction digit, in the following format.

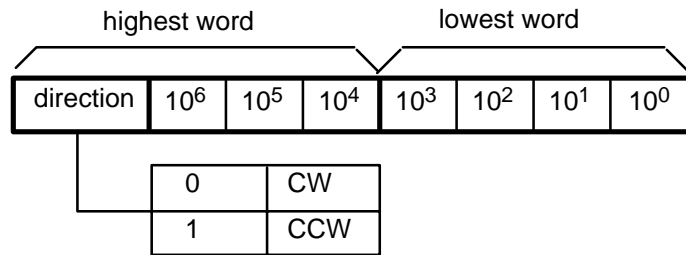

Note that the rightmost word is always the lowest word. If the two words were $n+8$ and $n+9$, for example, the rightmost word would be $n+8$ and the leftmost would be $n+9$. Furthermore, the rightmost digit in each word begins in the lowest bits. Thus, the digits $\times 10^4$ and $\times 10^0$ above would be held in bits 00 through 03 of their respective words. The direction digit also provides other information when required.

IR Allocation X-axis Output

Word	Bit	Function (\uparrow : leading edge; \downarrow : trailing edge)
Outputs (n = 100 x10 x unit no.) n	00	START: At the leading edge (\uparrow) of this bit, the Position Control Unit references bits 01 and 07 of word n+1 and begins positioning.
	01	Valid initial positioning no.: When set to 1, the initial positioning no. set in bits 07 to 00 of word n+1 is valid. When set to 0, the initial positioning no. set in bits 07 to 00 of DM word m is valid.
	02	ORIGIN SEARCH: (\uparrow) Searches for origin proximity signals and origin signals, and determines the origin.
	03	ORIGIN RETURN: (\uparrow) Returns to the origin (as long as the origin has already been determined).
	04	RELEASE PROHIBIT: (\uparrow)
	05	READ ERROR: (\uparrow)
	06	CHANGE SPEED: (\uparrow) if DIP switch pin no. 2 is ON. If pin no. 2 is OFF, then this bit executes CHANGE SPEED when set to 1 and STOP when set to 0.
	07	Valid speed coefficient: When set to 1, the speed coefficient set in bits 05 to 00 of word n+2 is valid. When set to 0, the speed coefficient of the target speed is set at 1.0.
	08	RESET ORIGIN: (\uparrow)
	09	TEACH: (\uparrow) References bits 15 to 08 of word n+1 and registers the present position.
	10	TRANSFER DATA: (\uparrow) References words n+2 to n+4 and begins the transfer of data.
	11	HIGH-SPEED JOG: (0: stops, 1: operates) in the direction indicated by bit 12 of word n.
	12	INCH/JOG direction: (0: CW, 1: CCW)
	13	LOW-SPEED JOG: (0: stops, 1: operates) in the direction indicated by bit 12 of word n.
	14	INCH: (\uparrow) Outputs one pulse.
	15	STOP: (\uparrow) The Positioning cannot be restarted while this bit is set to 1.
n+1	00 to 06	Initial positioning action number: 00 to 52 (BCD)
	07	Target speed/coefficient change
	08 to 14	TEACH positioning action number: 00 to 52 (BCD)
	15	BUFFER TRANSFER: (\uparrow)
n+2	00 to 05	Speed coefficient: 00 to 20 (BCD) in units of x 0.1 Speed numbers for CHANGE SPEED: 00 to 15 (00: current number + 1)
	06	Deviation counter reset output (A6-B6) forced ON/OFF bit (1: ON)
	07	Origin adjustment command output (A7-B7) forced ON/OFF bit (1: ON)
	08 to 14	Beginning transfer number: 00 to 58 (BCD)
	15	When set to 1, presets the present position during DATA TRANSFER.
n+3	00 to 15	Beginning word number for DATA TRANSFER (4 digits BCD)
n+4	00 to 07	DATA TRANSFER relay area 0-4 (BCD) (00: DM, 01: I/O, 02: LR, 03: HR, 04: AR)
	08 to 15	Quantity of data transmitted 01-59 (BCD)

IR Allocation X-axis Input

Word	Bit	Function ($\overline{\uparrow}$: leading edge; $\overline{\downarrow}$: trailing edge)	
Inputs (n = 100 x unit no. n+10	00	Positioning completed flag: ($\overline{\uparrow}$: completed, $\overline{\downarrow}$: starting)	
	01	Bank completed flag: ($\overline{\uparrow}$: bank completed, $\overline{\downarrow}$: starting)	
	02	At-origin flag: (1: stopped at origin)	
	03	Alarm flag: (1: alarm)	
	04	Emergency stop flag: $\overline{\uparrow}$:Emergency stop, $\overline{\downarrow}$:pulse output enabled word n+5 of bit 4	
	05	Error flag: (1: error)	
	06	Zone 0 flag: (0: outside zone 0, 1: inside zone 0)	
	07	Zone 1 flag: (0: outside zone 1, 1: inside zone 1)	
	08	Zone 2 flag: (0: outside zone 2, 1: inside zone 2)	
	09	Teaching completed flag: ($\overline{\uparrow}$: completed, $\overline{\downarrow}$: starting)	
	10	Transfer BUFFER TRANSFER also completed flag: ($\overline{\uparrow}$: completed, $\overline{\downarrow}$: starting)	
	11	No-origin flag: (1: no origin)	
	12	Busy flag: (1: busy) during transfer or pulse output (See note.)	
	13	CW limit flag: (1: CW limit signal has been detected.)	For external input monitoring
	14	CCW limit flag: (1: CCW limit signal has been detected.)	
		15	STOP flag: ($\overline{\uparrow}$: STOP executed, $\overline{\downarrow}$: operation begins)
n+11	00 to 15	Error code: 4 digits (BCD)	
n+12	00 to 06	Positioning action number: 00 to 52 (BCD)	
	07	Positioning completed flag: (1: positioning completed)	For external input monitoring
	08 to 11	Output code: 0 to F (hexadecimal)	
	12	Emergency stop signal: (1: Emergency stop signal is being input.)	For external input monitoring
	13	External interrupt signal: (1: External interrupt signal is being input.)	
	14	Origin signal: (1: Origin signal is being input.)	
15	Origin proximity signal: (1: Origin proximity signal is being input.)		
n+13	00 to 15	<div style="text-align: center;"> </div>	
n+14	00 to 15	<div style="text-align: center;"> </div>	

Note If the positioning time is very short, it may not be possible to read the busy flag's ON status in a ladder program cycle.

IR Allocation Y-axis Output

Word	Bit	Function (\uparrow : leading edge; \downarrow : trailing edge)
Outputs (n = 100 x10 x unit no.) n+5	00	START: At the leading edge (\uparrow) of this bit, the Position Control Unit references bits 01 and 07 of word n+1 and begins positioning.
	01	Valid initial positioning no.: When set to 1, the initial positioning no. set in bits 07 to 00 of word n+6 is valid. When set to 0, the initial positioning no. set in bits 07 to 00 of DM word m is valid.
	02	ORIGIN SEARCH: (\uparrow) Searches for origin proximity signals and origin signals, and determines the origin.
	03	ORIGIN RETURN: (\uparrow) Returns to the origin (as long as the origin has already been determined).
	04	RELEASE PROHIBIT: (\uparrow)
	05	READ ERROR: (\uparrow)
	06	CHANGE SPEED: (\uparrow) if DIP switch pin no. 5 is ON. If pin no. 5 is OFF, then this bit executes CHANGE SPEED when set to 1 and STOP when set to 0.
	07	Valid speed coefficient: When set to 1, the speed coefficient set in bits 05 to 00 of word n+7 is valid. When set to 0, the speed coefficient of the target speed is set at 1.0.
	08	RESET ORIGIN: (\uparrow)
	09	TEACH: (\uparrow) References bits 15 to 08 of word n+1 and registers the present position.
	10	TRANSFER DATA: (\uparrow) References words n+2 to n+4 and begins the transfer of data.
	11	HIGH-SPEED JOG: (0: stops, 1: operates) in the direction indicated by bit 12 of word n.
	12	INCH/JOG direction: (0: CW, 1: CCW)
	13	LOW-SPEED JOG: (0: stops, 1: operates) in the direction indicated by bit 12 of word n.
	14	INCH: (\uparrow) Outputs one pulse.
15	STOP: (\uparrow) The Positioning cannot be restarted while this bit is set to 1.	
n+6	00 to 06	Initial positioning action number: 00 to 52 (BCD)
	07	Target speed/coefficient change: (\uparrow)
	08 to 14	TEACH positioning action number: 00 to 52 (BCD)
	15	BUFFER TRANSFER: (\uparrow)
n+7	00 to 05	Speed coefficient: 00 to 20 (BCD) in units of x 0.1 Speed numbers for CHANGE SPEED: 00 to 15 (00: current number + 1)
	06	Deviation counter reset output (A6-B6) forced ON/OFF bit (1: ON)
	07	Origin adjustment command output (A7-B7) forced ON/OFF bit (1: ON)
	08 to 14	Beginning transfer number: 00 to 59 (BCD)
	15	When set to 1, presets the present position during DATA TRANSFER.
n+8	00 to 15	Beginning word number for DATA TRANSFER (4 digits BCD)
n+9	00 to 07	DATA TRANSFER relay area 0-4 (BCD) (00: DM, 01: I/O, 02: LR, 03: HR, 04: AR)
	08 to 15	Quantity of data transmitted 01-59 (BCD)

IR Allocation Y-axis Input

Word	Bit	Function (\uparrow : leading edge; \downarrow : trailing edge)	
Inputs (n = 100 x unit no. n+15)	00	Positioning completed flag: (\uparrow : completed, \downarrow : starting)	
	01	Bank completed flag: (\uparrow : bank completed, \downarrow : starting)	
	02	At-origin flag: (1: stopped at origin)	
	03	Alarm flag: (1: alarm)	
	04	Emergency stop flag: \uparrow :Emergency stop, \downarrow :pulse output enabled word n+5 of bit 4	
	05	Error flag: (1: error)	
	06	Zone 0 flag: (0: outside zone 0, 1: inside zone 0)	
	07	Zone 1 flag: (0: outside zone 1, 1: inside zone 1)	
	08	Zone 2 flag: (0: outside zone 2, 1: inside zone 2)	
	09	Teaching completed flag: (\uparrow : completed, \downarrow : starting)	
	10	Transfer completed flag: (\uparrow : completed, \downarrow : starting) BUFFER TRANSFER:(\downarrow)	
	11	No-origin flag: (1: no origin)	
	12	Busy flag: (1: busy) during transfer or pulse output (See note.)	
	13	CW limit flag: (1: CW limit signal has been detected.)	For external input monitoring
	14	CCW limit flag: (1: CCW limit signal has been detected.)	
		15	STOP flag: (\uparrow : STOP executed, \downarrow : operation begins)
n+16	00 to 15	Error code: 4 digits (BCD)	
n+17	00 to 06	Positioning action number: 00 to 52 (BCD)	
	07	Positioning completed flag: (1: positioning completed)	For external input monitoring
	08 to 11	Output code: 0 to F (hexadecimal)	
	12	Emergency stop signal: (1: Emergency stop signal is being input.)	For external input monitoring
	13	External interrupt signal: (1: External interrupt signal is being input.)	
	14	Origin signal: (1: Origin signal is being input.)	
15	Origin proximity signal: (1: Origin proximity signal is being input.)		
n+18	00 to 15	<div style="text-align: center;"> </div>	
n+19	00 to 15	<div style="text-align: center;"> </div>	

Note If the positioning time is very short, it may not be possible to read the busy flag's ON status in a ladder program cycle.

5-3 IR Area Settings

ORIGIN SEARCH

X: Bit 02 of word n
 Y: Bit 02 of word n+5

In C200H PCs, IR words 100 to 199 are used for Special I/O Units. When a Position Control Unit is used, some of these are allocated as I/O refresh areas. For a detailed explanation, refer to Section 3-2 Data Configuration and Allocation. For a detailed list of the words and bits in the IR area, refer to Section 5-1 IR Area Allocations.

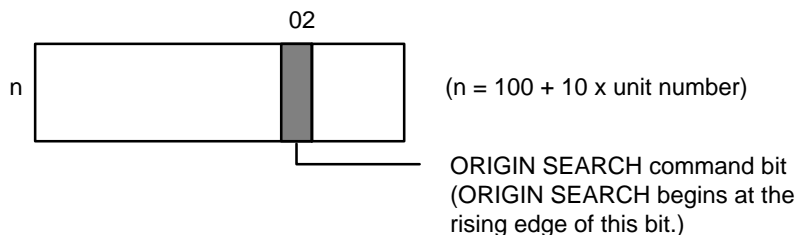

5-4 Execution Examples

The following examples illustrate the relationship between the mode number, presence or absence of a proximity signal, presence or absence of proximity reverse, and the execution of positioning actions. The origin and proximity signals both use N.O. inputs (bits 02 and 03 of DM word m+21 ON). An abbreviated explanation is given for the case with N.C. inputs.

Mode 0

Connect the open collector signals of the sensor, etc., to the origin line driver input (10 and 11 for X, 32 and 33 for Y) of the Position Control Unit. Origin response time is 1.0 ms. Refer to Section 2-4 Wiring.

Example 1: When Origin Proximity Reverse is Enabled

X: DM word m+21
Y: DM word m+121
(bit 01 ON, bit 04 ON)

As illustrated on the following page, use the origin proximity signal to ensure sufficient deceleration time when using a slit disc for the origin signal.

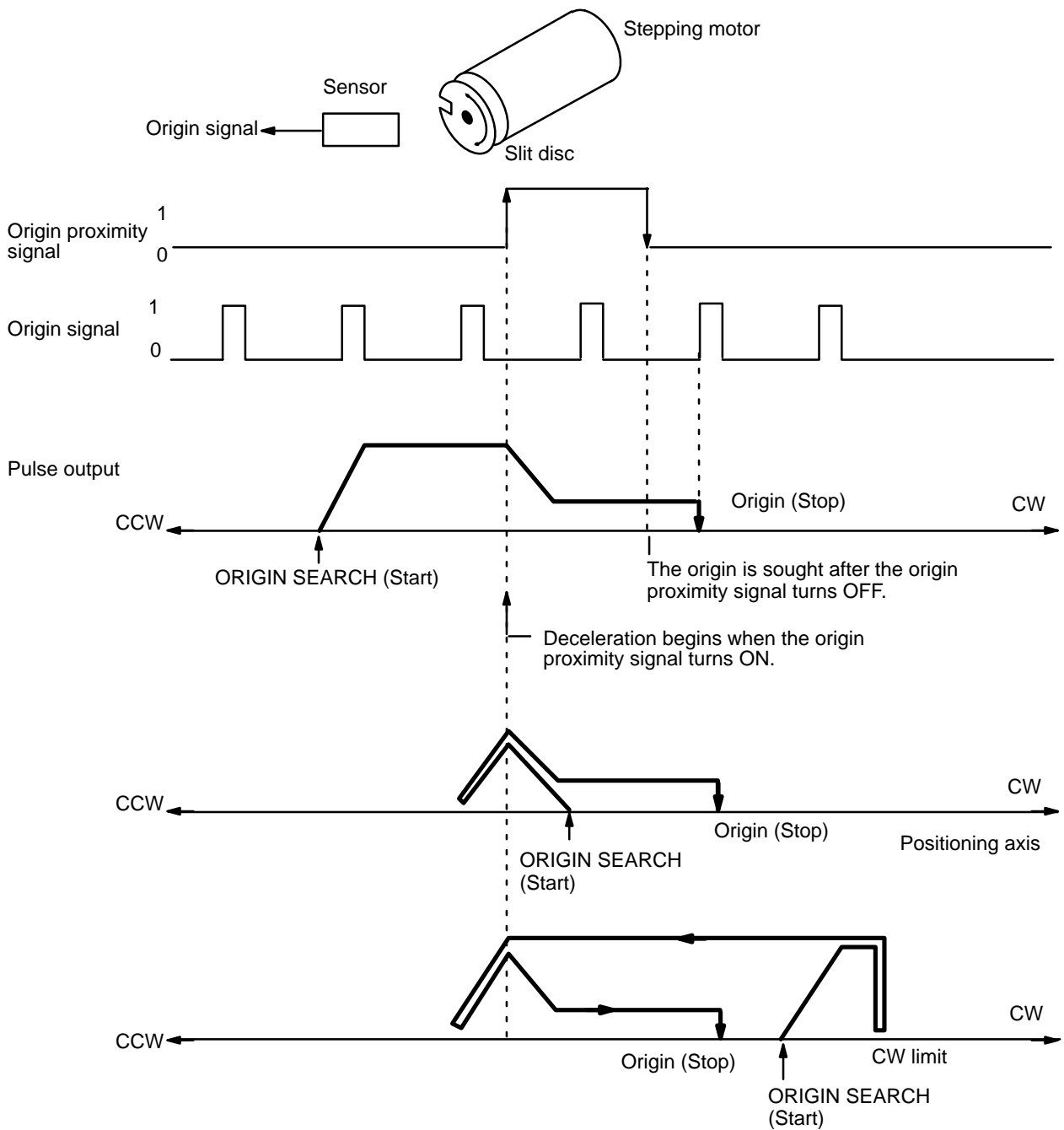

**Example 2:
When Origin Proximity
Reverse is Disabled**

X: DM word m+21
Y: DM word m+121
(bit 01 ON, bit 04 OFF)

This example shows one pulse of the proximity signal and one pulse of the origin signal.

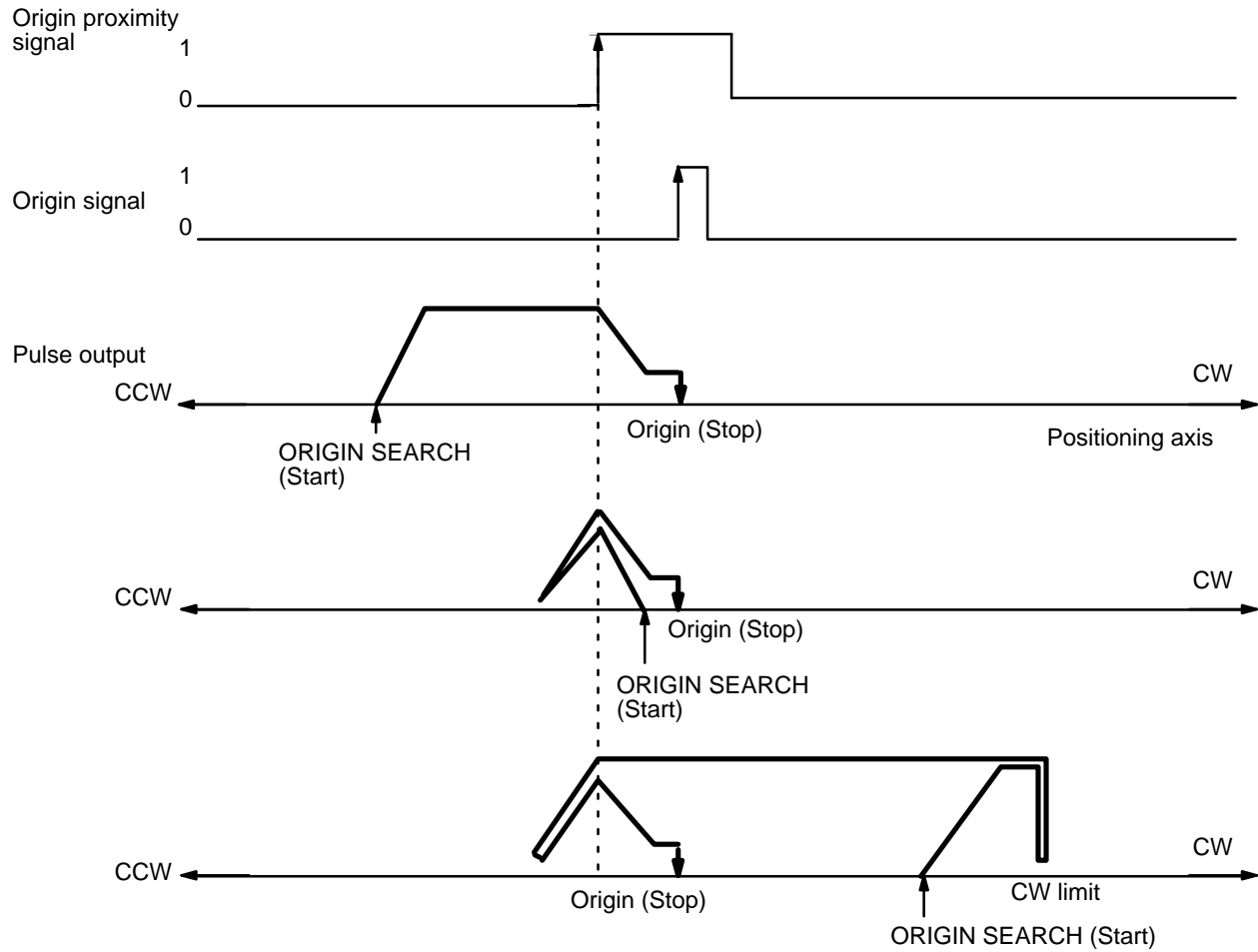

**Example 3:
No Origin Proximity Signal**

X: DM word m+21
Y: DM word m+121
(bit 01 OFF)

Only the origin signal is used. All positioning actions are carried out at proximity speed (low speed).

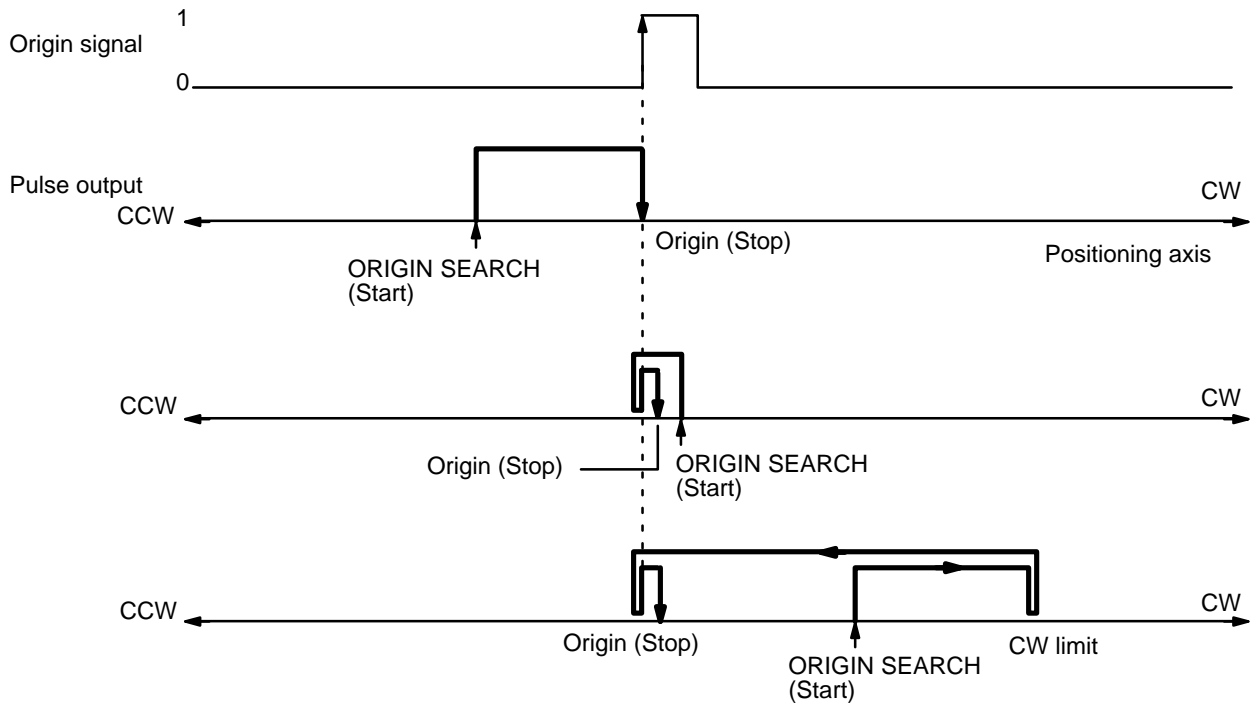

Mode 1

The Origin response time is 0.1 ms. Connect the encoder's Z-phase signal to inputs 9 and 11 for the X axis, and to inputs 31 and 33 for Y axis. Be sure to use the proximity signal. Also refer to the wiring information in Section 2-4.

Note In mode 1, the proximity signal is used even if the axis is set for "No proximity signal" (bit 01 OFF.)

**Example 1:
When Origin Proximity
Reverse is Enabled**

X: DM word m+21
Y: DM word m+121 (bit 01 ON, bit 04 ON)

Use the origin proximity signal to ensure sufficient deceleration time when origin proximity reverse is needed.

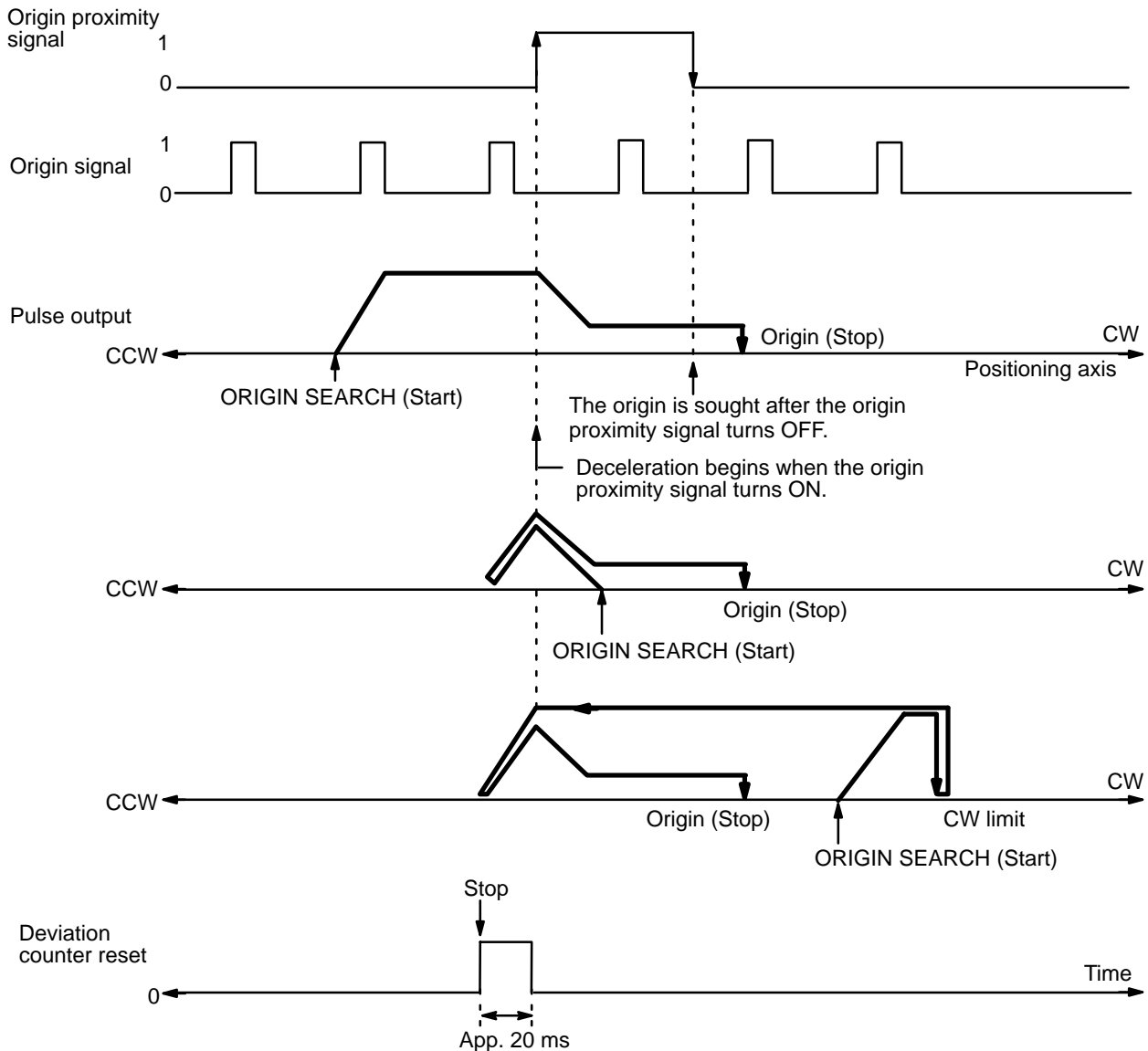

After positioning has stopped, a deviation counter reset signal of about 20 ms is output.

In this mode, if deceleration has not ended when the origin proximity signal has turned OFF, positioning is stopped by the origin signal input after deceleration has ended. If the deceleration period is short for some reason (such as starting inside the origin proximity area), the Position Control Unit will detect another origin signal. Therefore, be sure that the origin proximity signal period is long enough, i.e., at least as long as the deceleration period.

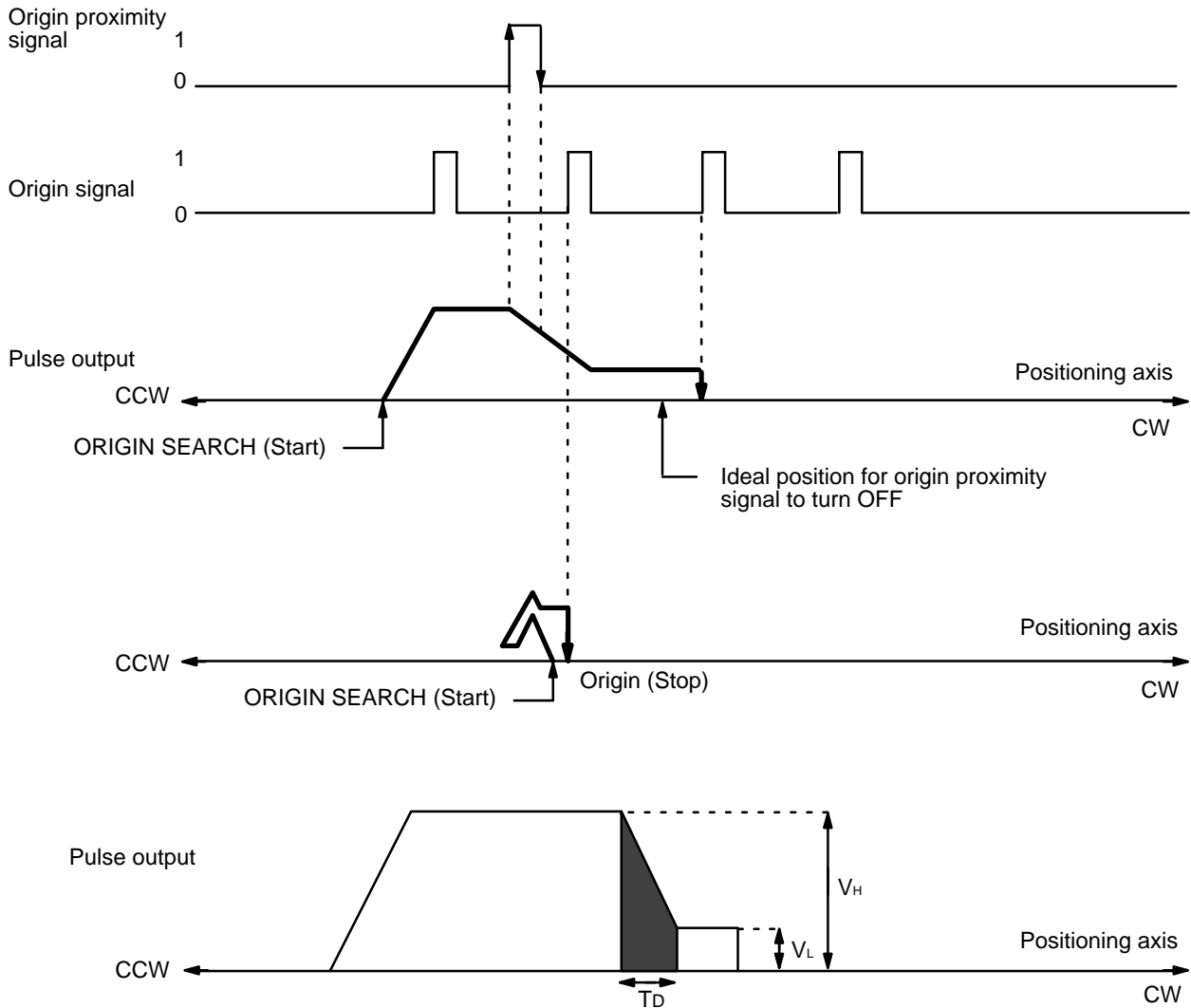

A general method for calculating the number of pulses within the deceleration interval is presented below.

Deceleration time $T_D = (V_H - V_L) / 1000 \times R$,
 where R: deceleration data (pps/1 ms);

Number of pulses P_D for deceleration period $= (V_H + V_L) \times T_D / 2$
 $= (V_H^2 - V_L^2) / 2000 \times R$.

If $V_H = 20000$ pps, $V_L = 1000$ pps, and $R = 1000$ pps/ms,
 then $P_D = (20000^2 - 1000^2) / 2000 \times 100 = 1995$.

Therefore, approximately 2,000 pulses are required for deceleration.

**Example 2:
When Origin Proximity
Reverse is Disabled**

X: DM word m+21

Y: DM word m+121 (bit 01 ON, bit 04 OFF)

In this example, origin proximity reverse is not used. Positioning stops when the first origin signal is input after deceleration has ended.

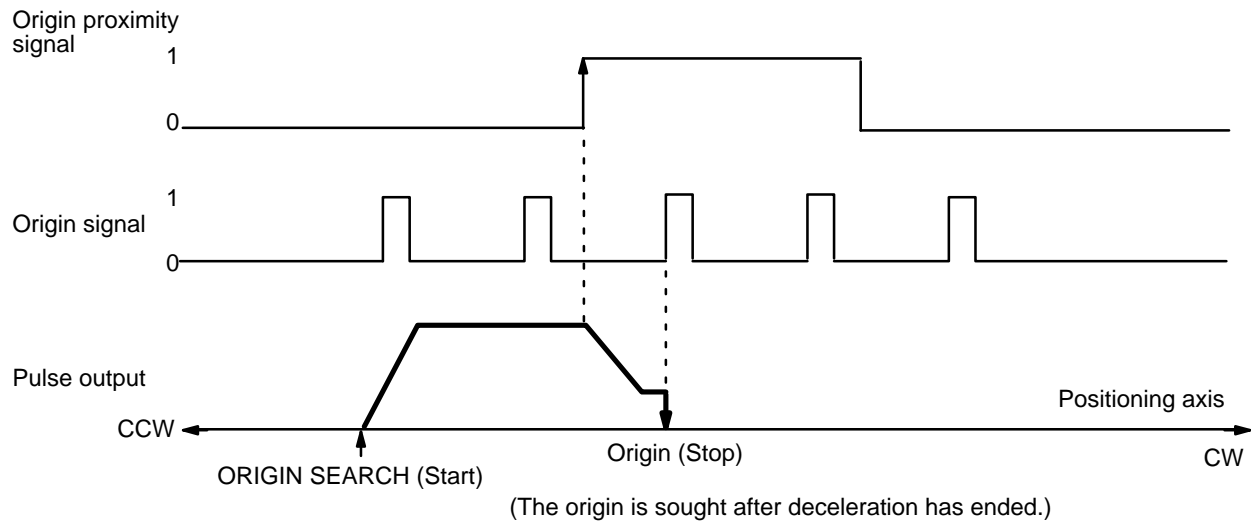

Be aware that when there is an origin signal during deceleration, the stop position depends on the length of the deceleration interval.

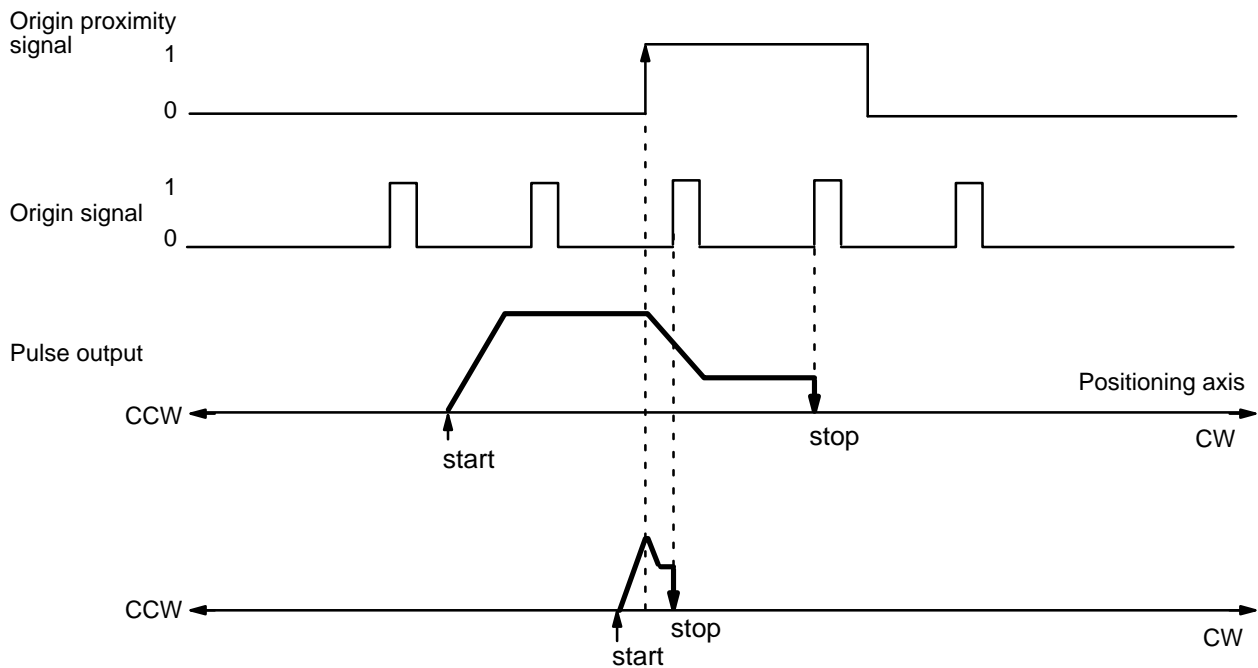

In this example diagram, deceleration from ORIGIN SEARCH high speed to proximity speed (low speed) is completed in the period between the origin proximity signal and the first origin signal.

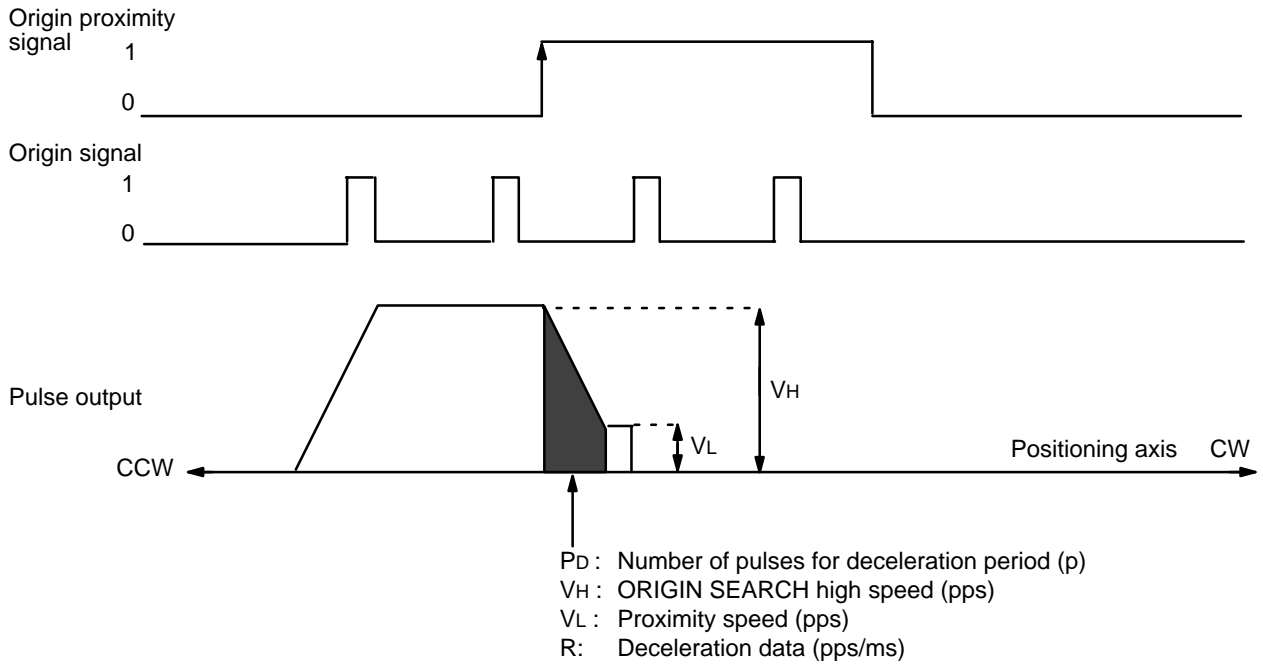

$$P_D = [(V_H + V_L) \times (V_H - V_L/1000 \times R)]/2 = (V_H^2 - V_L^2/2000 \times R)$$

Set the values of V_H and R , using this expression, so that the value of P_D falls within the range shown in the above figure.

Mode 2

This mode is similar to Mode 1, but the servomotor driver positioning completed signal is also used. For the connection of this signal, refer to 2-4 Wiring.

The busy flag turns OFF when the positioning completed signal has been input. Keep the dwell time set to 0, for however long the dwell time is set, the busy flag takes that much longer to turn OFF.

Note In mode 2, the proximity signal is used even if the axis is set for “No proximity signal” (bit 01 OFF.)

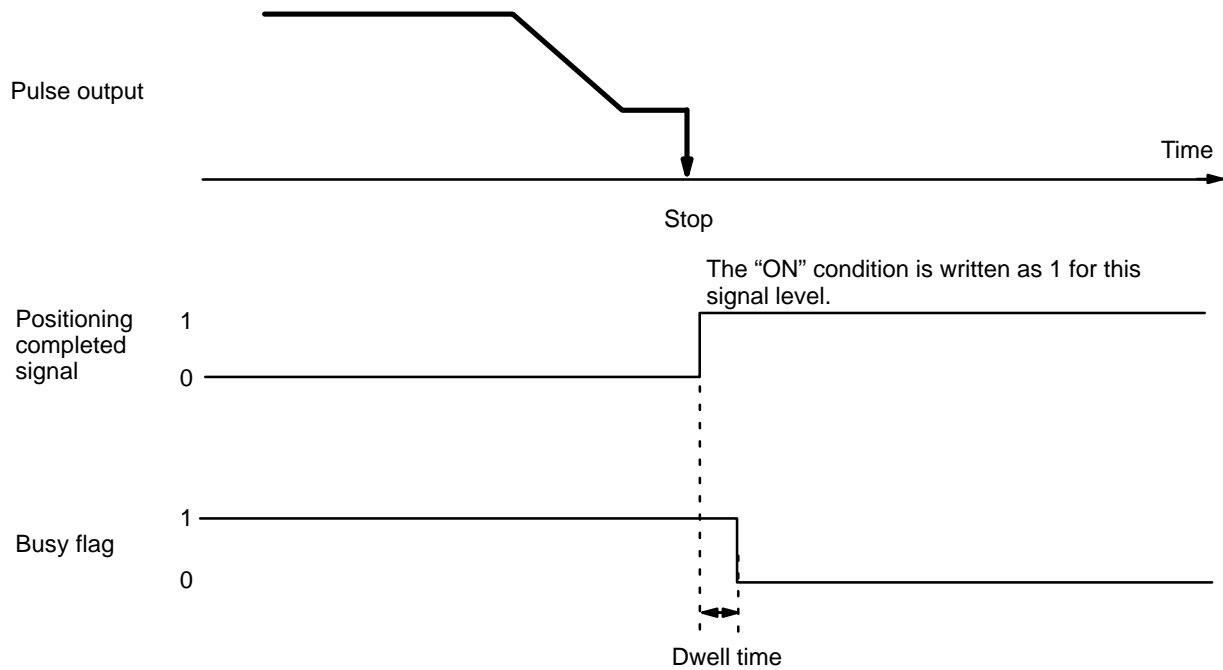

Mode 3

Mode 3 makes use of the origin adjustment functions of OMRON Servomotor Drivers R88D-EP and R88D-SR. The servomotor's positioning completed signal (INP) is used as the origin search completion signal. Do not use an origin, Z-phase, or deviation counter reset signal.

Note In mode 3, the proximity signal is used even if the axis is set for "No proximity signal" (bit 01 OFF.)

**Example 1:
When Origin Proximity
Reverse is Enabled**

X: DM word m+21
Y: DM word m+121
(bit 01 ON, bit 04 ON)

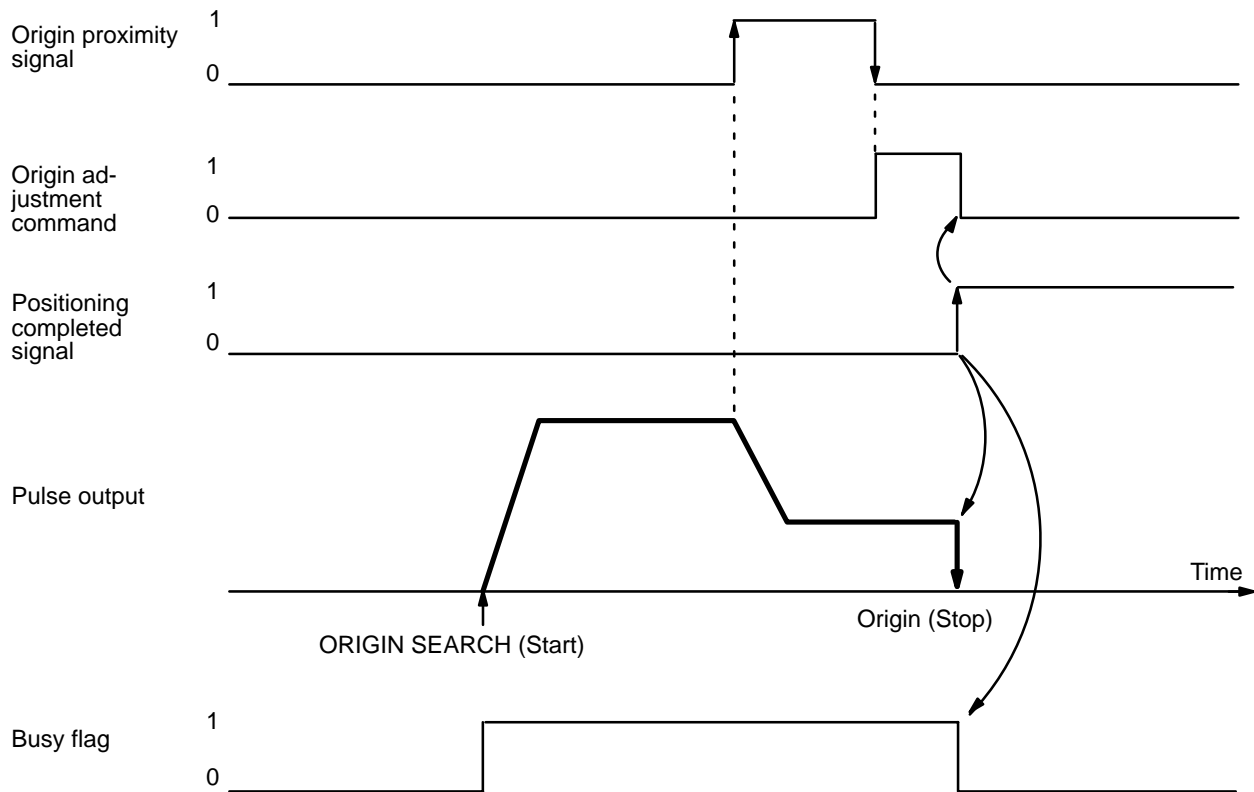

When the servomotor driver receives the origin adjustment command (H.RET) from the Position Control Unit, the deviation counter of the servomotor driver is internally reset by the Z-phase signal (which is output by the encoder) and the servomotor driver stops.

Servomotor Driver Processing:

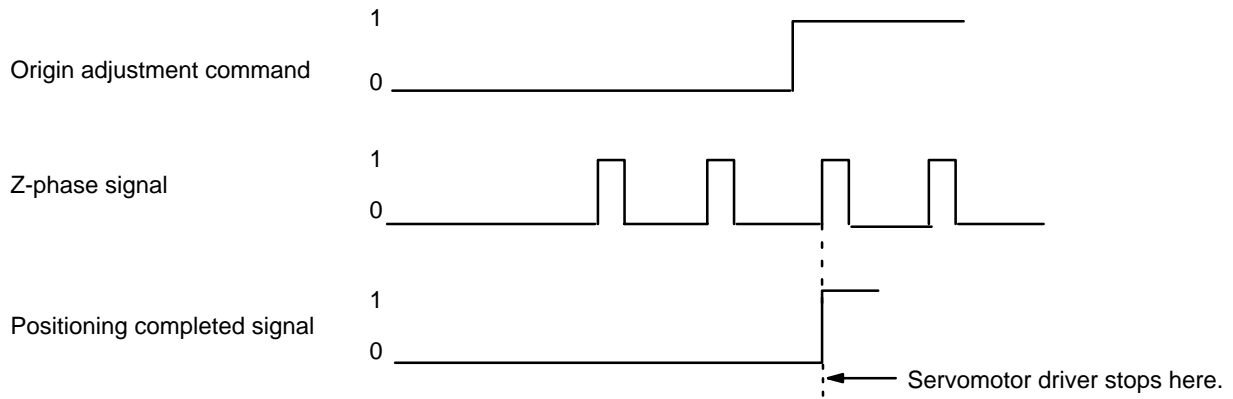

The point at which positioning stops is the same as in modes 1 and 2. There are some differences in operation depending on the starting position for ORIGIN SEARCH. For details, refer to the examples under Mode 1.

Refer also to the examples under Mode 1 for certain precautions concerning the length of the origin proximity signal. In mode 3, if deceleration has not ended by the time the origin proximity signal has turned OFF, the origin adjustment signal is output when deceleration ends.

**Example 2:
When Origin Proximity
Reverse is Disabled**

X: DM word m+21
Y: DM word m+121
(bit 01 ON, bit 04 OFF)

In this example, origin proximity reverse is not used. The origin adjustment command is output after deceleration has ended.

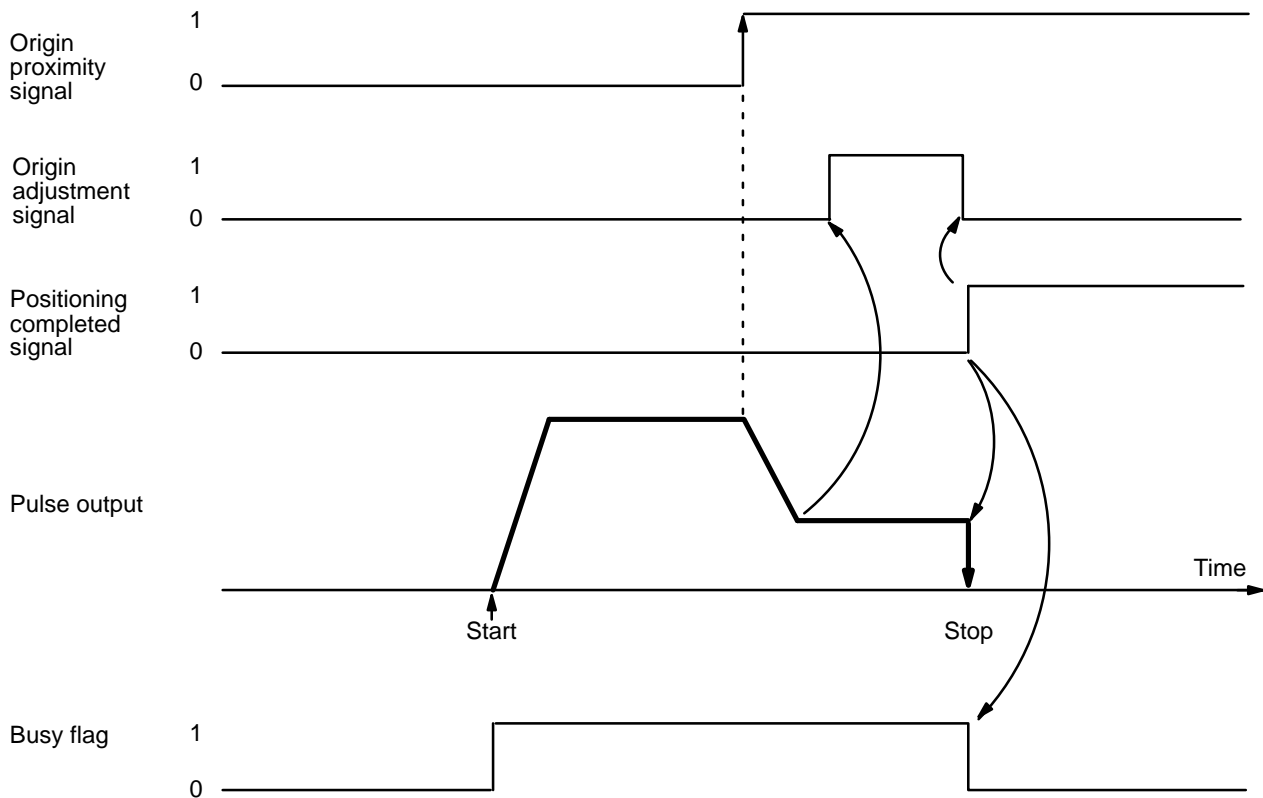

If the Z-phase signal is input from the encoder during deceleration, the point at which positioning is stopped differs depending on the length of the deceleration period.

For details on calculating the number of pulses during deceleration, refer to Mode 1, Example 2: *When Origin Proximity Reverse is Disabled*.

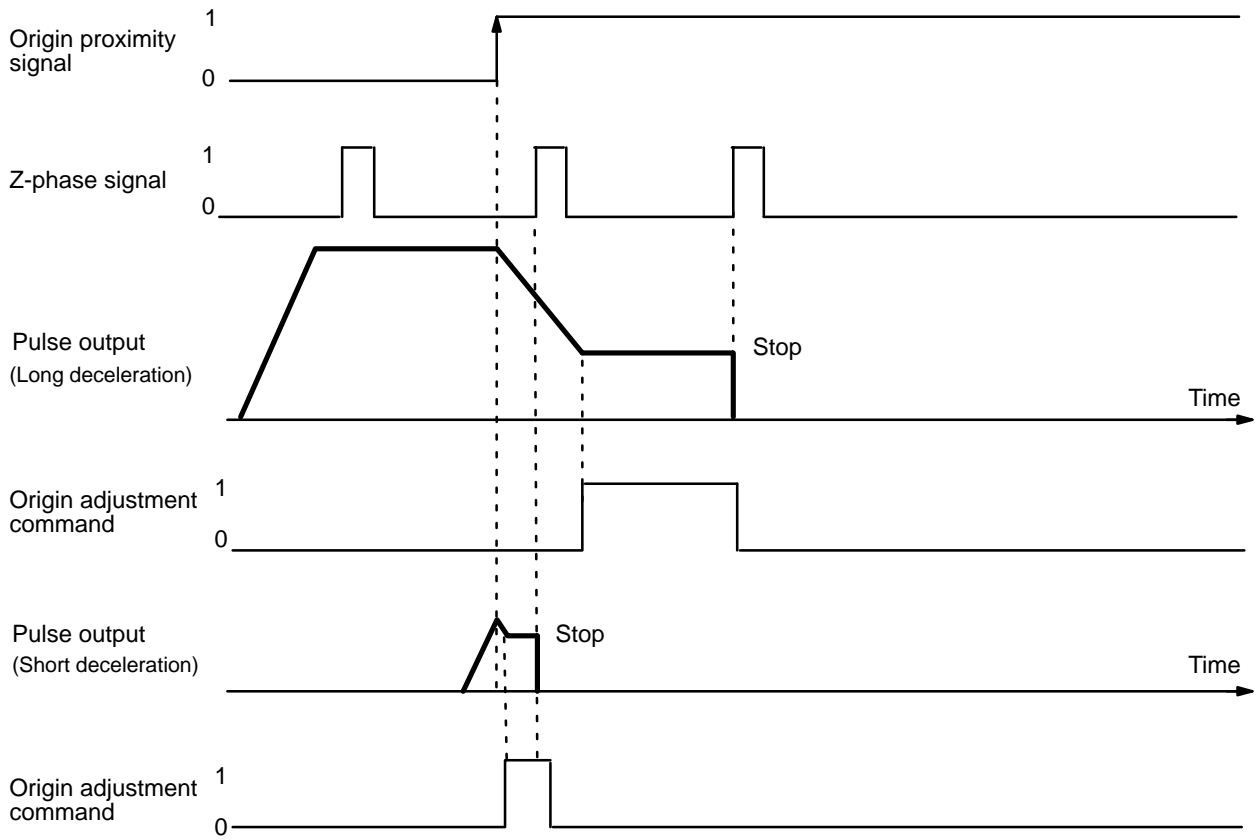

5-5 ORIGIN SEARCH Completion Examples

Completion Patterns With an Origin Proximity Signal
 X: DM word m+23
 Y: DM word m+123
 (bit 01 ON)

The following two example diagrams both illustrate completion of ORIGIN SEARCH when an origin proximity signal is present. There is an origin compensation value set in the second example, but not in the first.

Example 1: Without Origin Compensation

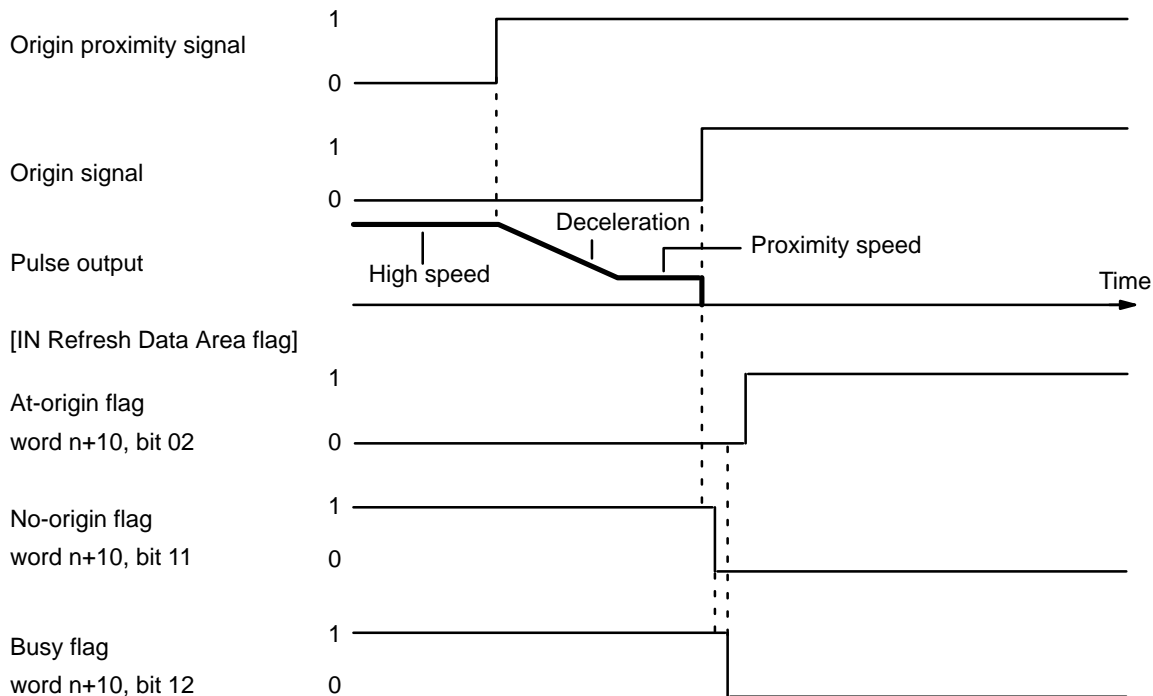

Example 2: With Origin Compensation

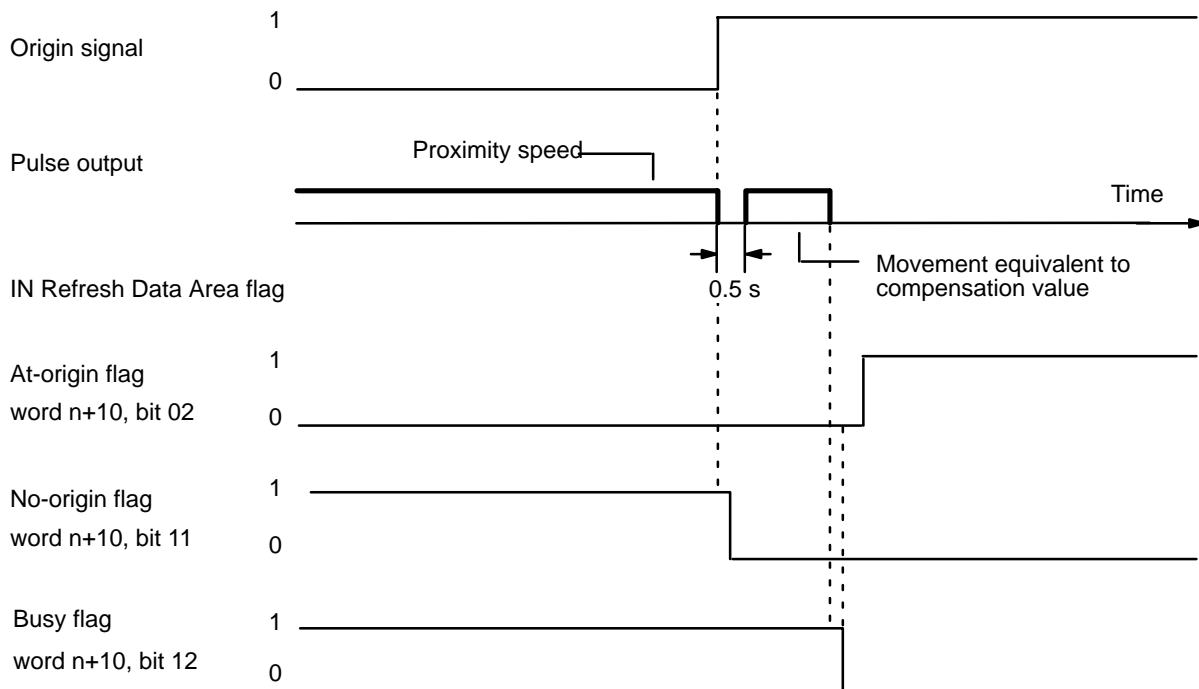

Program Example

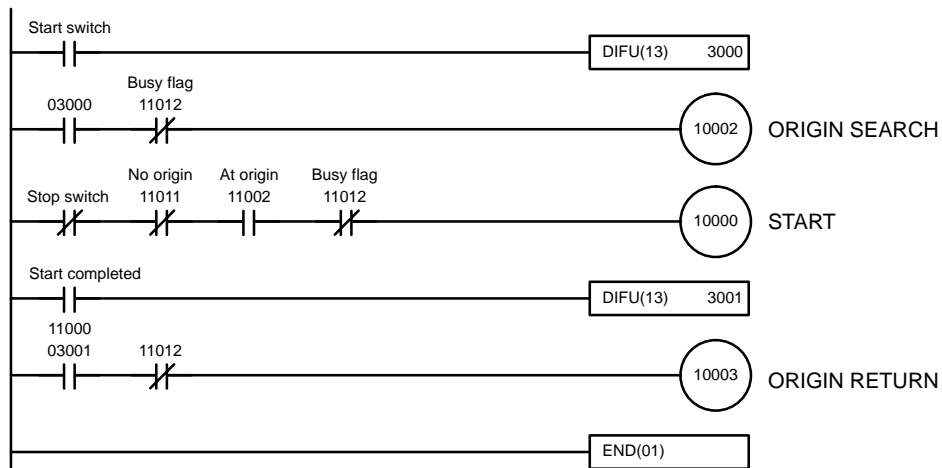

**Completion Patterns
Without an Origin Proximity
Signal**

X: DM word m+21
Y: DM word m+121
(bit 01 OFF)

The following two example diagrams both illustrate completion of ORIGIN SEARCH when no origin proximity signal is present. There is an origin compensation value set in the second example, but not in the first.

Example 1: Without Origin Compensation

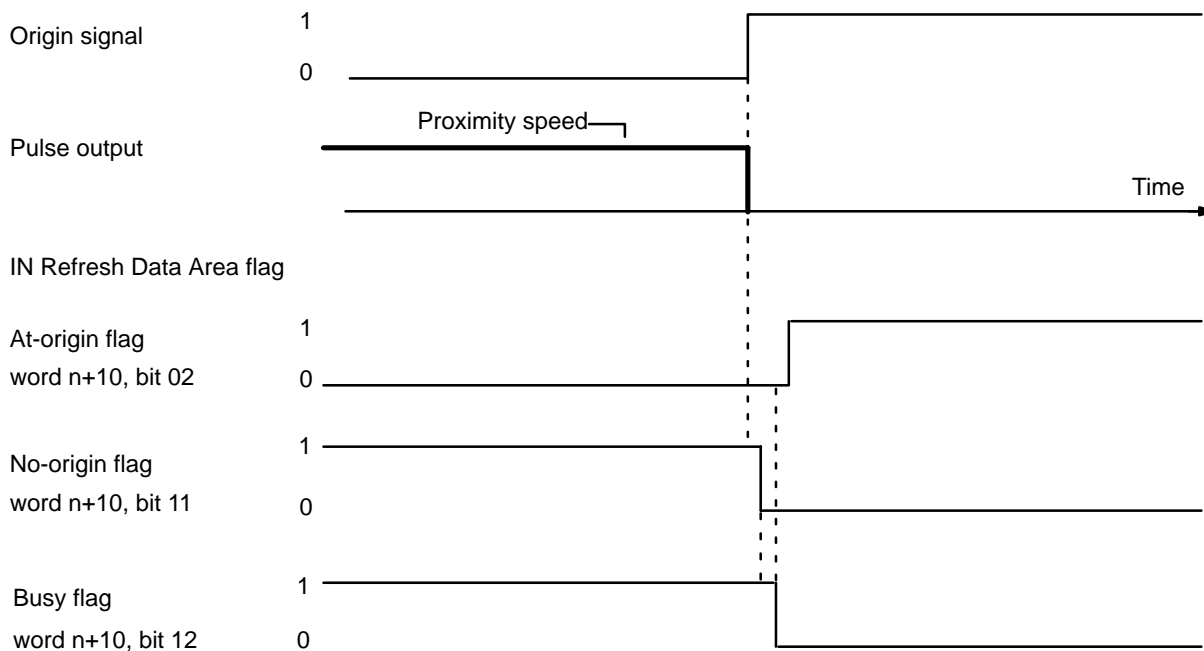

5-6 Start/Stop

In C200H PCs, IR words 100 to 199 are used for Special I/O Units. When a Position Control Unit is used, some of these words are allocated as I/O refresh areas. For a detailed explanation, refer to Section 3-2 Data Configuration and Allocation.

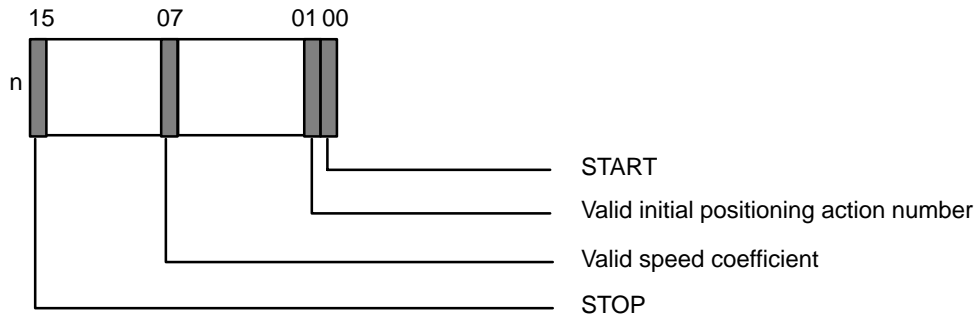

START

X: Bit 00 of word n
 Y: Bit 00 of word n+5

When bit 00 turns ON, the settings in bits 01 and 07 are referenced and positioning begun. For interpolation moves use bit 00 of word n only; bit 00 of word n+5 (Y axis start) is not valid.

START Activation Time

The time required between START command bit recognition and the beginning of pulse output depends on the combinations of position data to be executed.

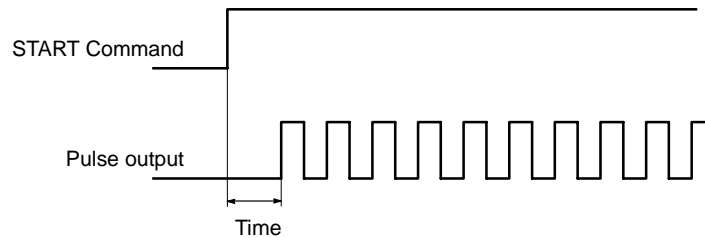

Pattern	START activation time		
	Starting the Y axis alone while the X axis is stopped Starting the X axis alone while the Y axis is stopped	Starting the Y axis alone while the X axis is moving Starting the X axis alone while the Y axis is moving	Interpolation startup
Pattern 0	18 to 21 ms	18 to 21 ms	27 to 29 ms
Pattern 1 (no. of data = 2)	18 to 21 ms	18 to 21 ms	27 to 29 ms
Pattern 1 (no. of data = max.)	18 to 21 ms	18 to 21 ms	27 to 29 ms
Pattern 2 (no. of continuous data = 2)	18 to 21 ms	18 to 21 ms	27 to 30 ms
Pattern 2 (no. of continuous data = max.)	38 to 41 ms	41 to 44 ms	80 to 83 ms
Pattern 3	18 to 21 ms	18 to 21 ms	27 to 29 ms
Pattern 4	18 to 21 ms	18 to 21 ms	---
Pattern 5	18 to 21 ms	18 to 21 ms	---

Note Maximum number of data items = 53

External Interrupt Response Time

The time required between CHANGE SPEED or STOP command bit recognition and the beginning of execution is at least 4 ms.

Valid Initial Positioning Action Number

X: Bit 01 of word n
Y: Bit 01 of word n+5

1	Bits 07-00 of word n+1 valid
0	Bits 07-00 of DM word m valid

Set this bit to 1 when you have designated the initial positioning number in the I/O refresh areas. After the initial position is set with bits 07 to 00 of word n+1, set the START command bit. These values are set within the same scan.

Set to zero for the first START after the power is turned on, operation after bank end, and operation after positioning action number 19 (or 52 if using an expanded DM area).

Valid Speed Coefficient

X: Bit 07 of word n
Y: Bit 07 of word n+5

Used when the target speed of the positioning action is to be multiplied by a coefficient. Set the speed coefficient in bits 07 to 00 of word n+2, and then the START command bit within the same scan. This bit can function simultaneously with bit 01 above. When this bit is ZERO, the target speed during START becomes 1.0. For an example of valid speed coefficient operation, refer to Section 6-9 CHANGE SPEED COEFFICIENT.

Deceleration/Stop Command (STOP)

X Bit 15 of word n
Y: Bit 15 of word n+5

This bit turns ON when STOP is executed during pulse output. Declaration begins at the deceleration setting of DM word m+99., and eventually stops when a speed of zero is reached. Pulse output cannot be executed as long as this bit remains ON. Refer to Section 6-7 STOP for a more detailed explanation and several examples of STOP execution.

Initial Positioning Action Number

When the START command bit (bit 00 of word n) turns ON, START is executed with the positioning action number specified here if bit 01 of word n is ONE.
X: Bits 06-00 of word n+1
Y: Bits 06-00 of word n+6

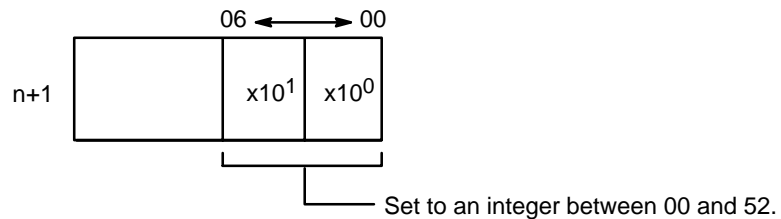

Speed Coefficient

X: Bits 05-00 of word of word n+2
X: Bits 05-00 of word of word n+7

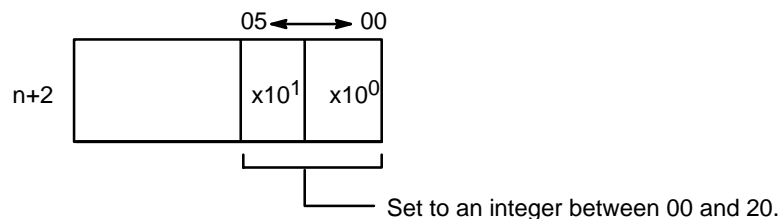

This setting represents units of (0.1). A setting of 15, for example, represents a value of (1.5).

This coefficient is valid if bit 07 of word n is ONE when the START command bit (bit 00 of word n) turns ON. It is valid only during START and cannot be changed during operation.

The speed coefficient represents a coefficient of the target speed. If its value is set at 00, the speed will be taken at face value and a coefficient of 1.0 will be applied. If the value is set between 01 and 20, the set value will be multiplied by 0.1 to determine the coefficient. The speed coefficient can thus be set in increments from 0.1 to 2.0.

If the speed resulting from the coefficient exceeds 250 kpps or falls below 1 kpps, the speed will be set at 250 kpps or 1 kpps, respectively. The target speed coefficient is taken in when started or when the target speed coefficient change flag, bit 07 of word n+1 for the X axis and n+6 for the Y axis, is turned ON. When the target speed changes during operation, set bit 07 of word n+1 to ON after changing the target speed. The target speed coefficient has no effect on accelerations and decelerations.

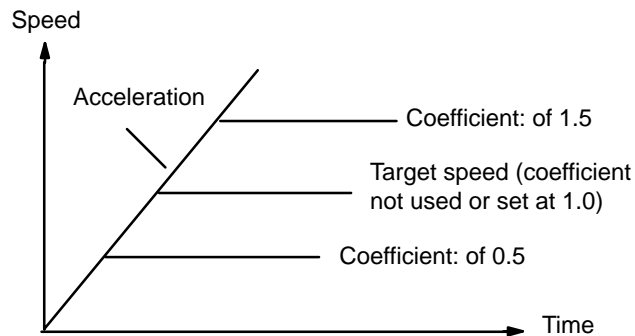

Deviation Counter Reset Output Signal

X: Bit 06 of word n+2
Y: Bit 06 of word n+7

Bit 06 is only valid during STOP. The deviation counter reset output (A6, B6) is ON if this bit is set to 1, and OFF if it is set to 0.

Origin Adjustment Output Signal

X: Bit 07 word n+2
Y: Bit 07 word n+7

Bit 07 is only valid during STOP or manual operation (JOG or INCH). Origin adjustment output is ON if this bit is set to ONE, and OFF if it is set to ZERO.

SECTION 6

Manual Operations

6-1	IR Area Settings	126
6-2	HIGH-SPEED JOG	127
6-3	LOW-SPEED JOG	128
6-4	INCH	129
6-5	RESET ORIGIN	130
6-6	External Interrupt Commands	131
6-7	STOP	134
6-8	CHANGE SPEED	146
6-9	CHANGE SPEED COEFFICIENT	147

Section Overview

There are three manual feeding commands: HIGH-SPEED JOG, LOW-SPEED JOG and INCH. Acceleration and deceleration are possible with HIGH-SPEED JOG, but not with LOW-SPEED JOG. INCH operates one pulse at a time. The following explanations are made with respect to the X-axis, but the case of the Y-axis is the same.

6-1 IR Area Settings

In C200H PCs, IR words 100 to 199 are used for Special I/O Units. When a Position Control Unit is used, they are allocated as I/O refresh areas. For a detailed explanation, refer to Section 3-2 Data Configuration and Allocation. For a detailed table of words and bits in the IR area, refer to Section 5-1 IR Area Allocations.

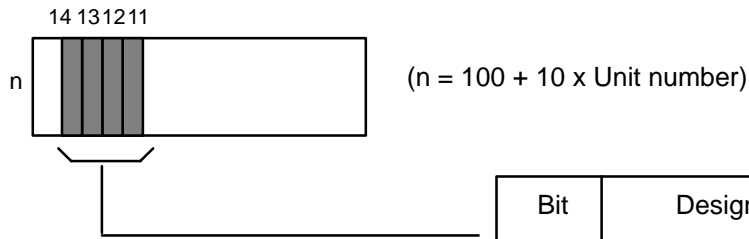

Bit	Designation	1	0
11	HIGH-SPEED JOG	operate	stop
12	JOG/INCH direction	CCW	CW
13	LOW-SPEED JOG	operate	stop
14	INCH	INCH begins on the rising edge of this bit.	

6-2 HIGH-SPEED JOG

The LOW-SPEED JOG command (word n, bit 11) causes the Unit to manually feed at the designated speed (effective on signal's rising edge). Feeding starts when the command bit is set and continues until it is reset.

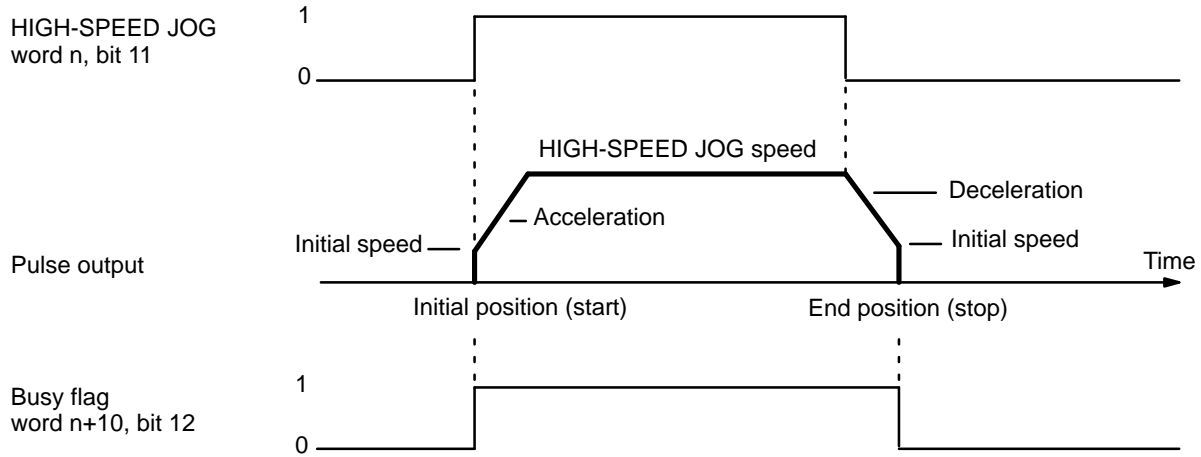

6-3 LOW-SPEED JOG

The LOW-SPEED JOG command (bit 13 of word n) causes the Unit to manually feed at the designated speed (effective on signal's rising edge). Feeding starts when the command bit is set and continues until it is reset.

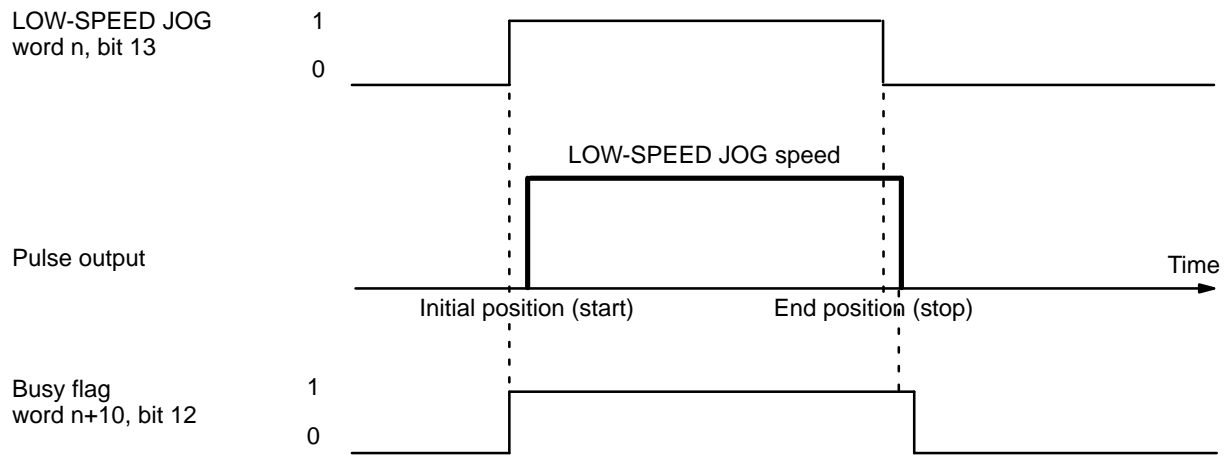

6-4 INCH

The INCH command (bit 14 of word n) causes the Unit to manually inch one pulse at a time (effective on signal's rising edge). One pulse will be feed each time this bit is set.

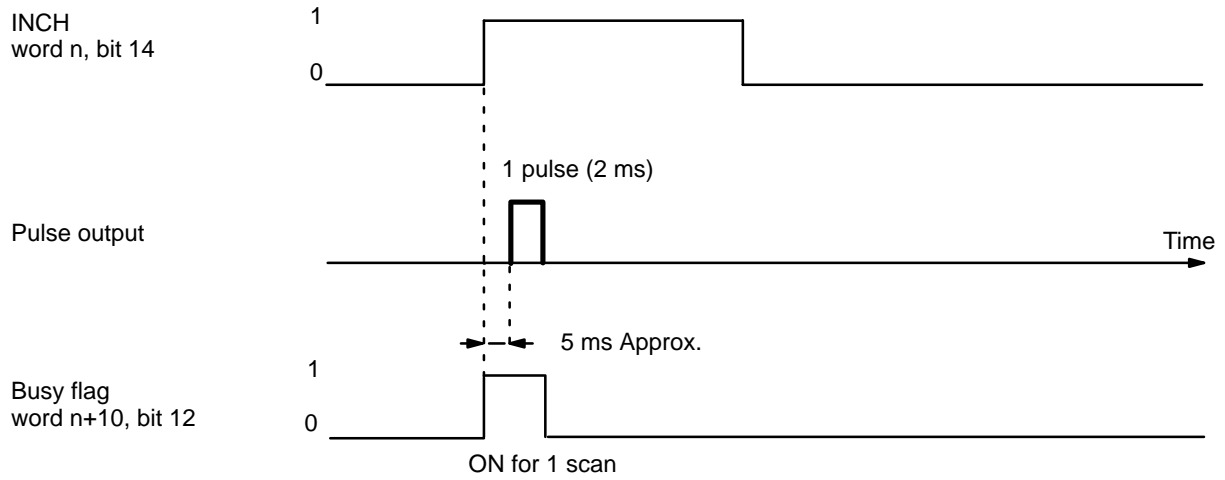

The busy flag turns ON for only one scan when the scan time is 12 ms or more. When the scan time is less than 12 ms, it may turn ON for two scans.

6-5 RESET ORIGIN

The RESET ORIGIN command bit, bit 08 of word n, is set to redefine the present position as the origin (effective on signal's rising edge). Although the following example uses the X axis, the case of the Y axis is essentially the same.

Execution Example

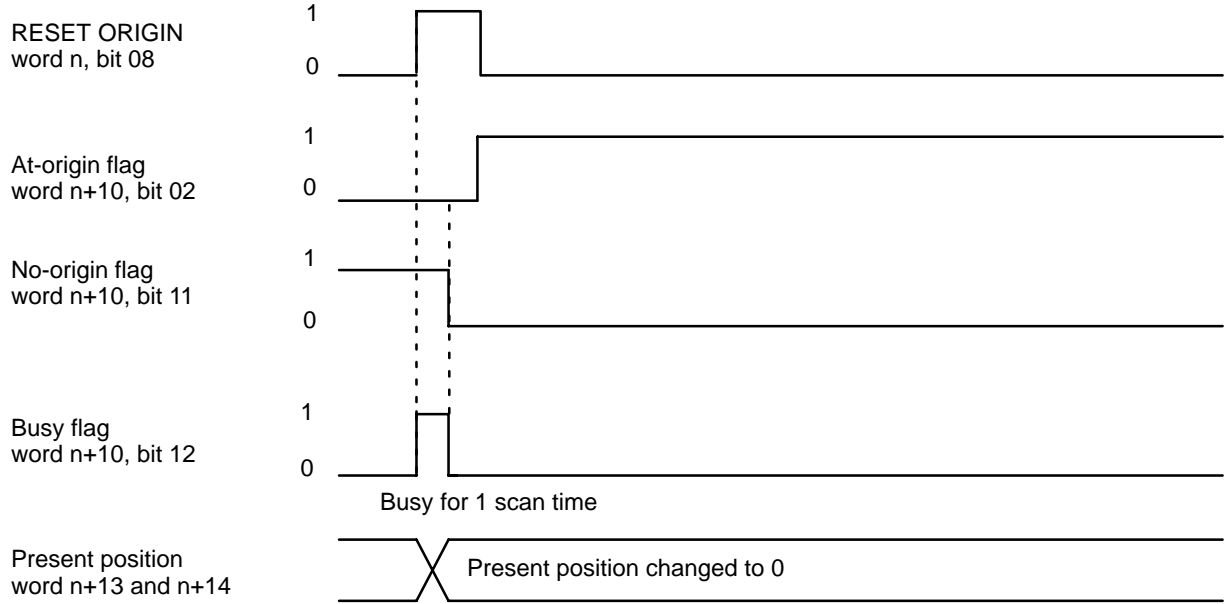

See Example 9-2 Programming Examples for more information on using RESET ORIGIN.

6-6 External Interrupt Commands

Positioning can be stopped and speeds can be changed by either the bits set in the IR area or by external interrupt signal input. Specify the target speeds to be used for CHANGE SPEED with the speed numbers set in bits 05 to 00 of IR word n+2. If those bits are set to ZERO, the next speed number after the one currently being executed will be taken as the target speed.

When executing CHANGE SPEED with an external input, designate the speed number from IR word n+2 at least one scan time in advance or it will not be in time. Otherwise, when designating the speed number, use an IR area work bit. (See IR Area Settings below).

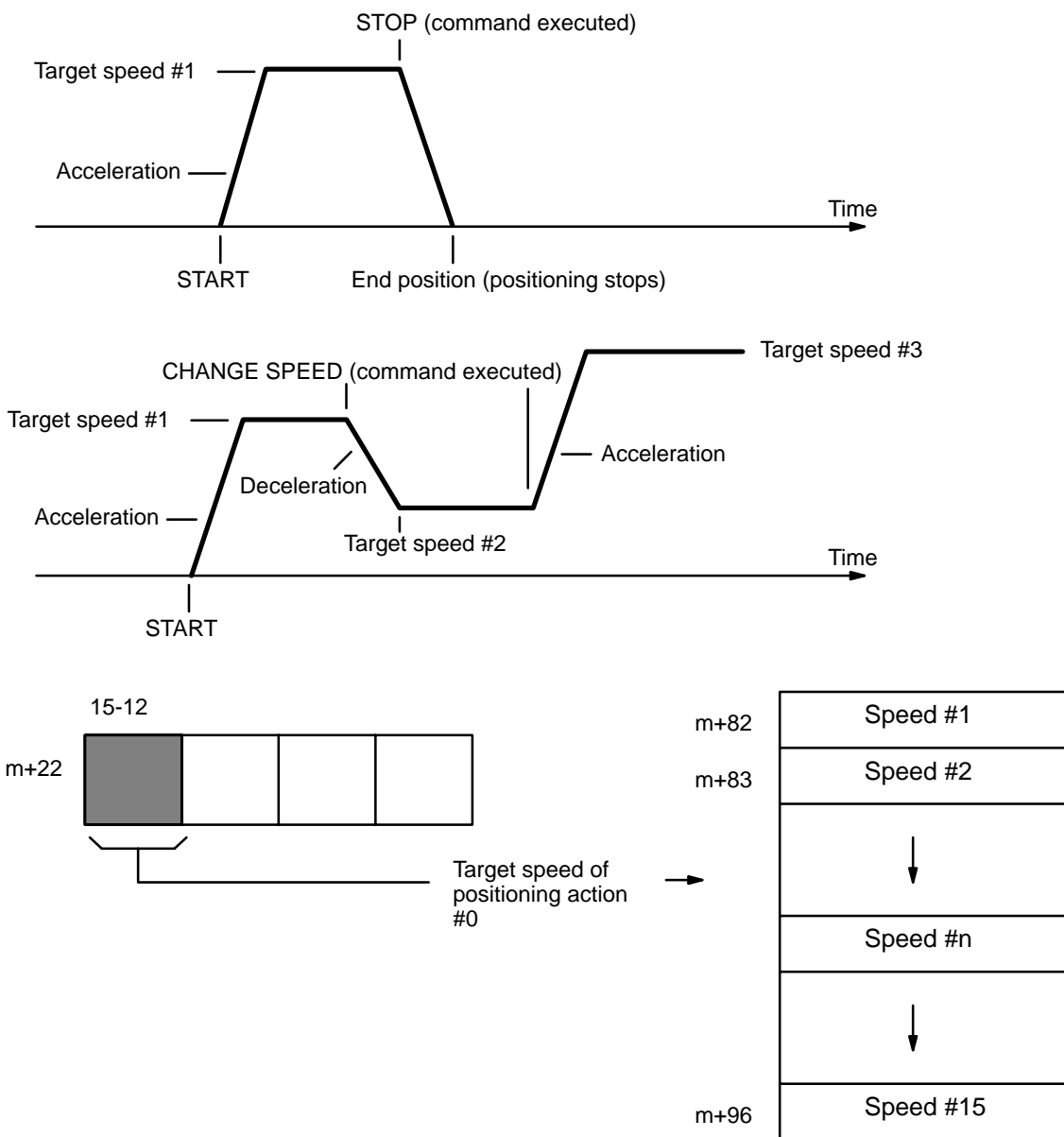

Connection for External Interrupt Signal

The signal's rising edge is acknowledged as the input signal.

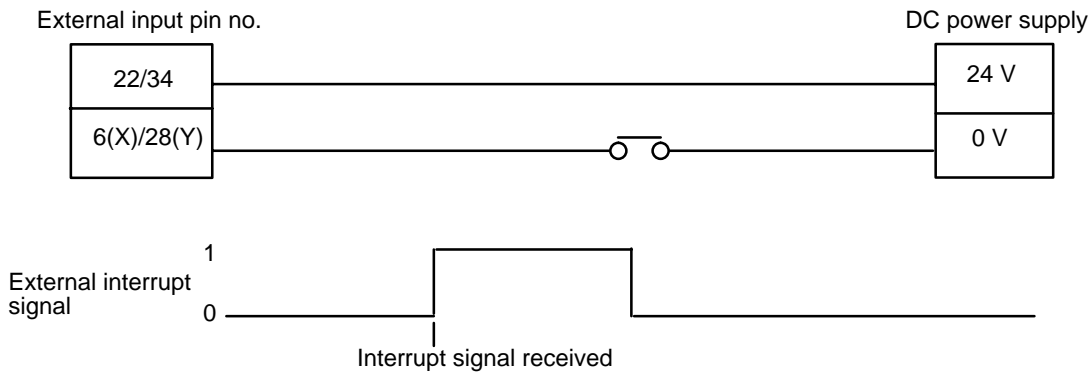

DIP Switch Settings

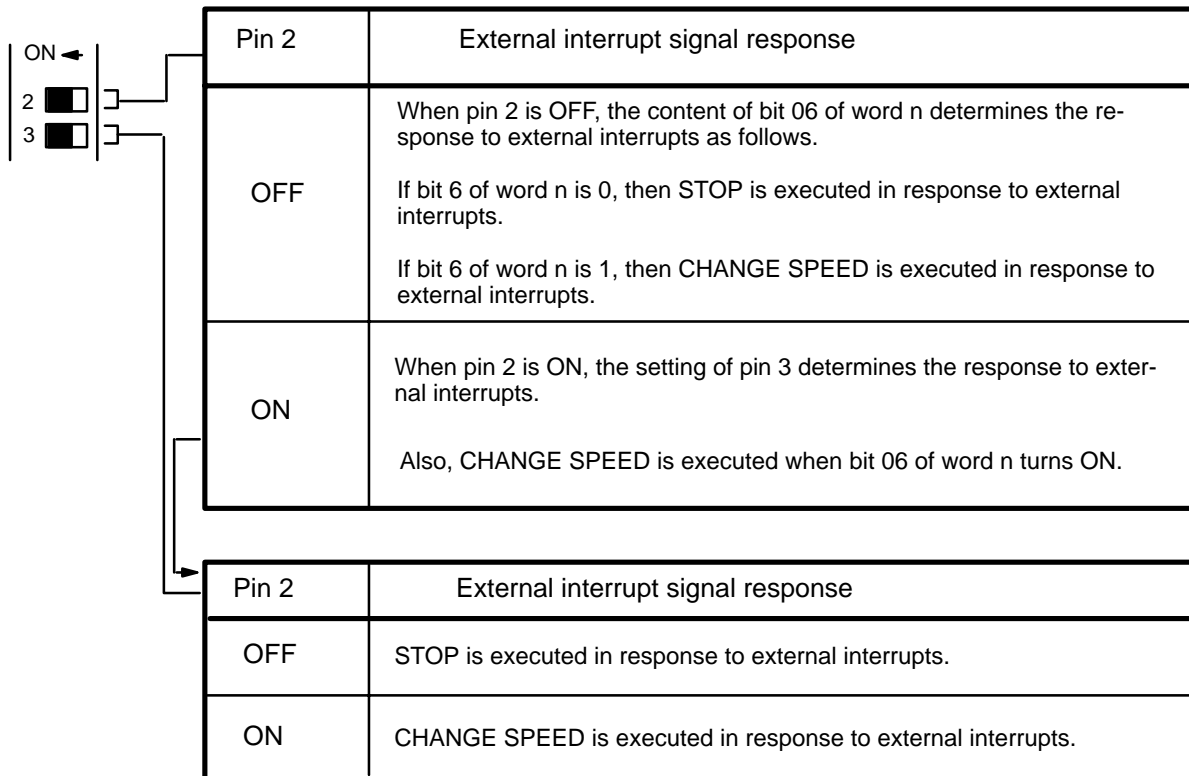

There are thus two ways to execute STOP: through an external interrupt or through the command bit, bit 15 of word n. Both of these methods are available at the same time if bit 06 of word n is ZERO and pin 2 is OFF, or if pin 2 is ON and pin 3 is OFF.

There are also two ways to execute CHANGE SPEED: through an external interrupt, or if pin 2 is ON, directly with bit 06 of word n as the command bit. Execution through an external interrupt is available if bit 06 of word n is ONE and pin 3 is OFF, or if pins 2 and 3 are both ON. In the latter case, execution through the command bit and external interrupt are both available.

Note that START cannot be executed as long as STOP (either from bit 15 of word n or from an external interrupt signal) is in effect.

IR Area Settings

In addition to bits 15 and 06 of word n (described under DIP Switch Settings above), set bits 05 to 00 of word n+2. If these bits are set to ZERO, the next speed number after the one currently being executed will be taken as the target speed for CHANGE SPEED. If they are set to from 01 to 15, then that will specify the speed number to be taken as the target speed.

When executing CHANGE SPEED with an external interrupt signal, the data from this area must be written in at least one scan time before the interrupt signal. When executing CHANGE SPEED with a work bit (bit 06 of word n), it can be written simultaneously with the rising edge of the work bit.

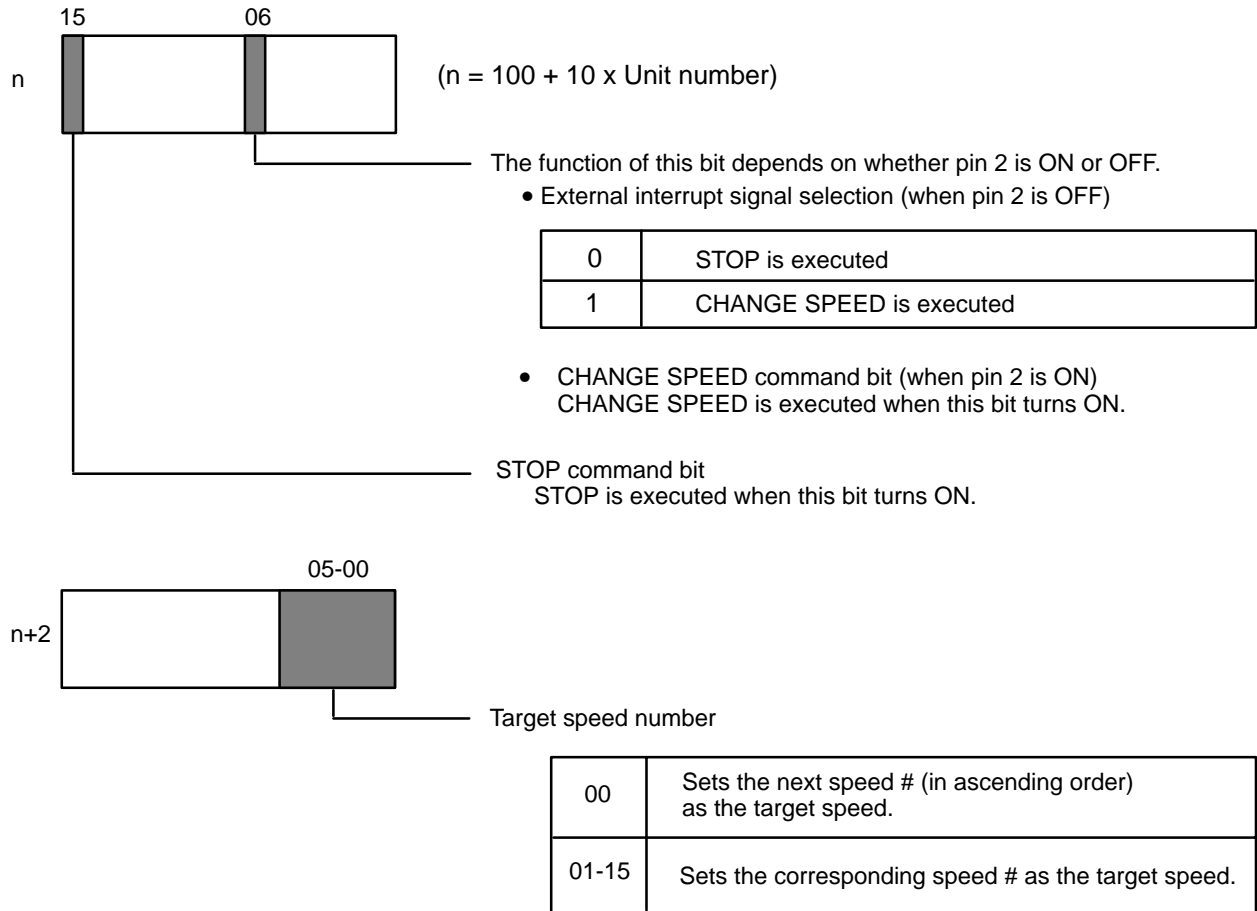

When an external interrupt signal functions as the CHANGE SPEED command signal, this area cannot be written to more than 1 scan prior to signal input. When the IR area (bit 06 of word of word n) functions as the CHANGE SPEED command bit, setting this bit and writing to word n+2 are done simultaneously.

6-7 STOP

STOP can be executed during pulse output for START, ORIGIN SEARCH, ORIGIN RETURN, HIGH-SPEED JOG, and LOW-SPEED JOG to decelerate to a stop (effective on signal's rising edge). Note, however, that the next START cannot be executed as long as STOP (either from bit 15 of word n or from an external interrupt signal) is in effect.

STOP Executed During START

When the STOP command bit is set during execution of a positioning action under START, the positioning completed flag is not turned ON, and the positioning action number not changed. When START is next executed, the target position and speed of that action will be used, as long as the target position has not been exceeded. The busy flag, however, turns OFF, allowing manual operations to be used up to the next START.

Consider, for example, execution using the following DM words and data.

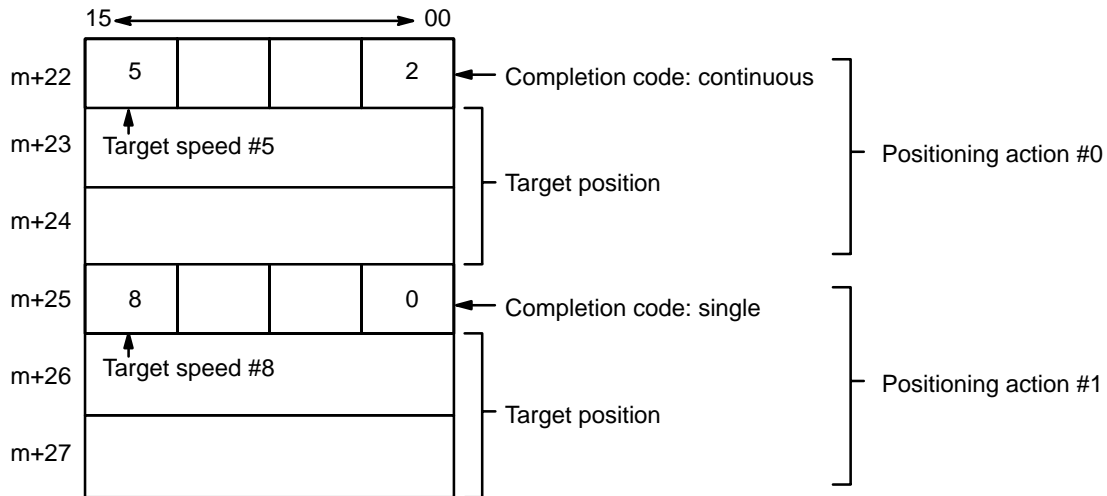

Example 1

The first example illustrates what happens when STOP is not executed.

START
word n, bit 00

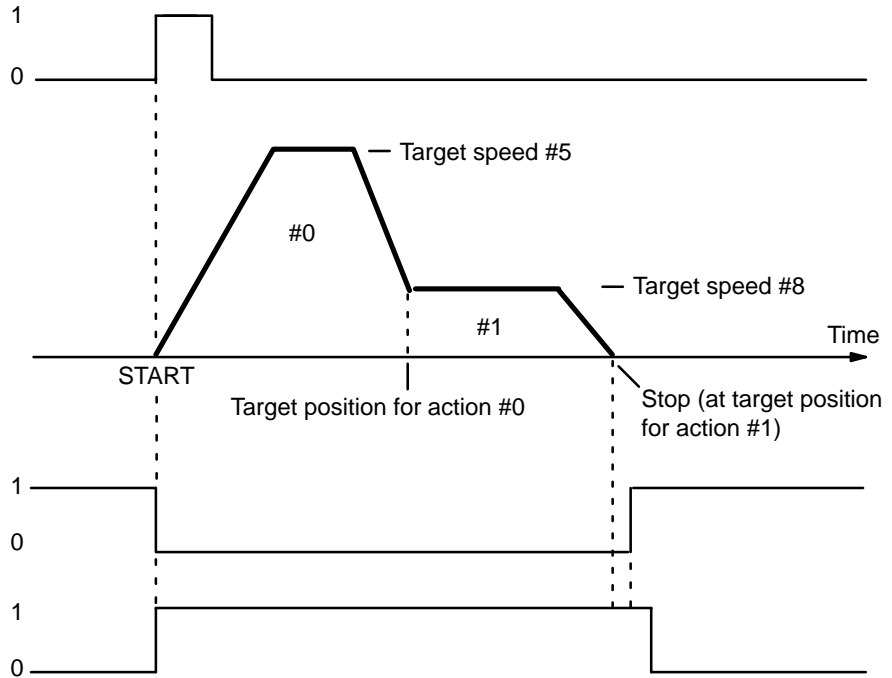

Example 2

This example shows STOP execution when the target position is not exceeded and the target position is designated from the origin (i.e., is not an increment). When START is next executed, the data of the positioning action at the time of STOP is taken as the target position.

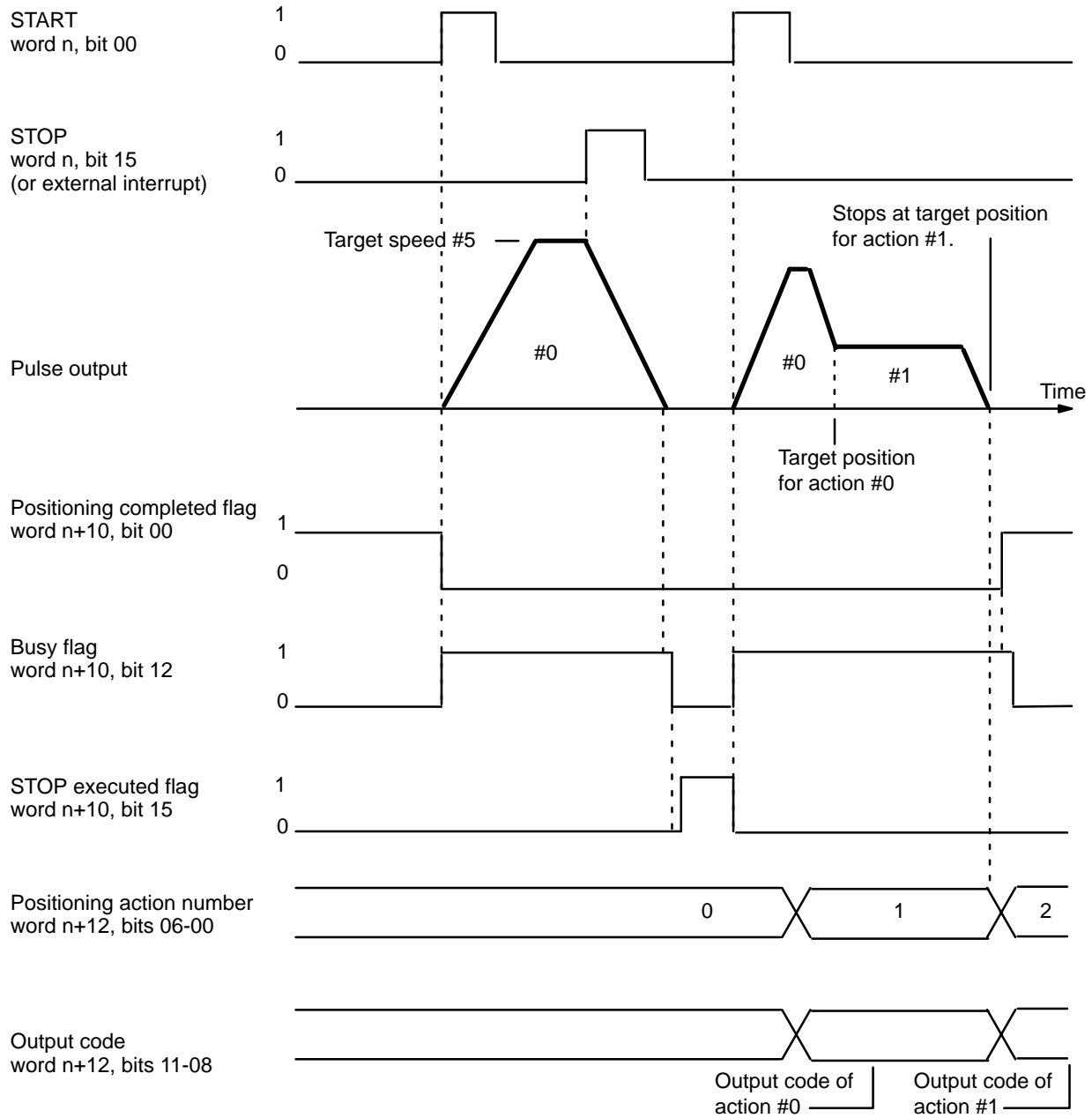

When the STOP executed flag for either the X or Y axis turns ON, the Unit stops interpolation. Restart using the X-axis START command.

Example 3

This example shows execution when a target position designated from the origin (i.e., not an increment) is exceeded during deceleration of STOP, which can happen if STOP is executed at the end of a continuous positioning action. If START is executed again before this situation is corrected, the feeding direction for the action will be wrong, and an error (code 5020) will be generated because the action cannot begin. The Unit can be restarted after manually feeding (with JOG) back to the other side of the target position for action #0.

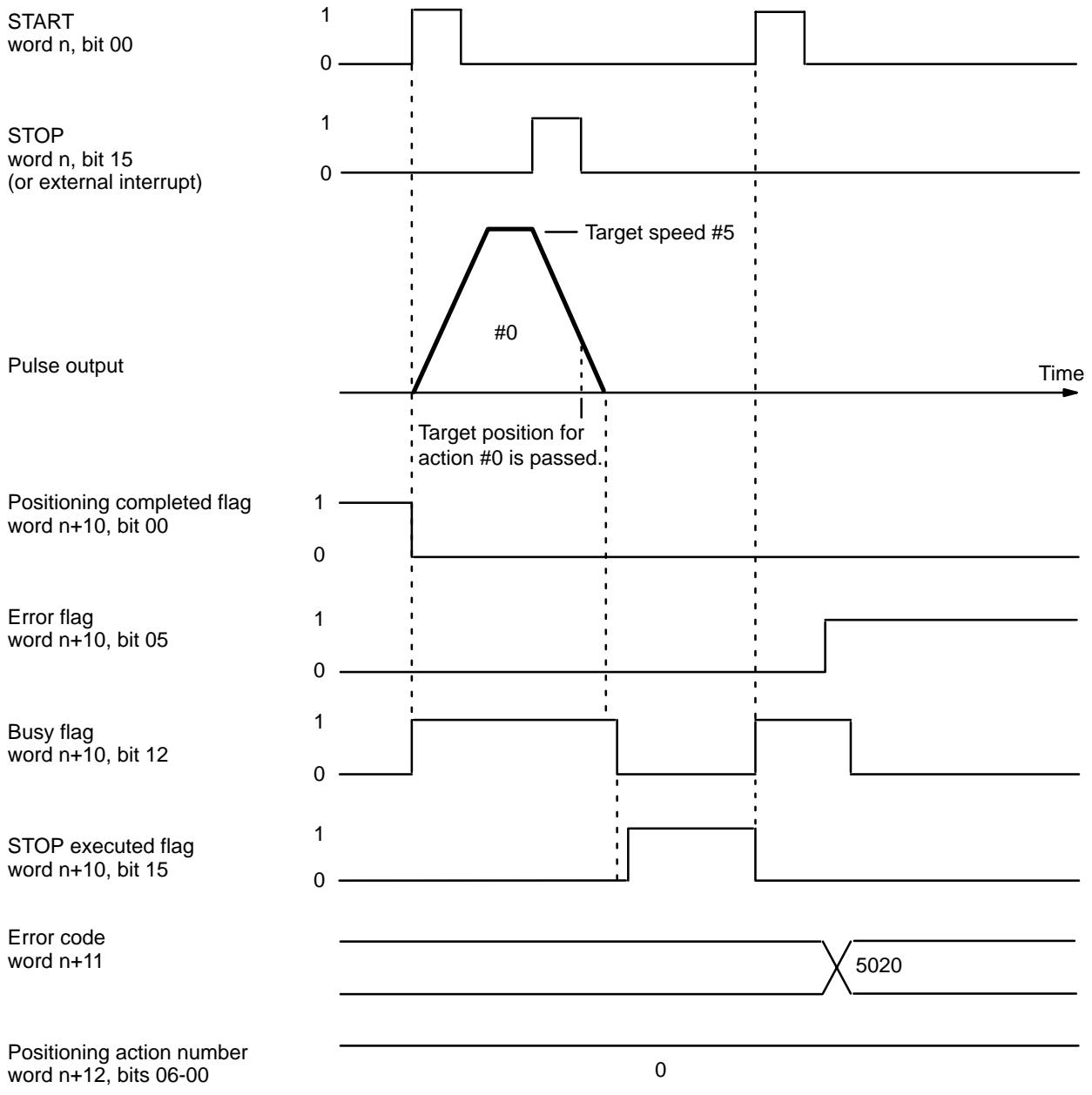

This error is also generated if the target position for action #0 is exceeded by manual operations before START is executed following STOP. With interpolation, use JOG to return to the target position on both the X and Y axes.

Example 4

When the target position is expressed as an increment, the positioning action will be started over automatically from the position reached after STOP was executed.

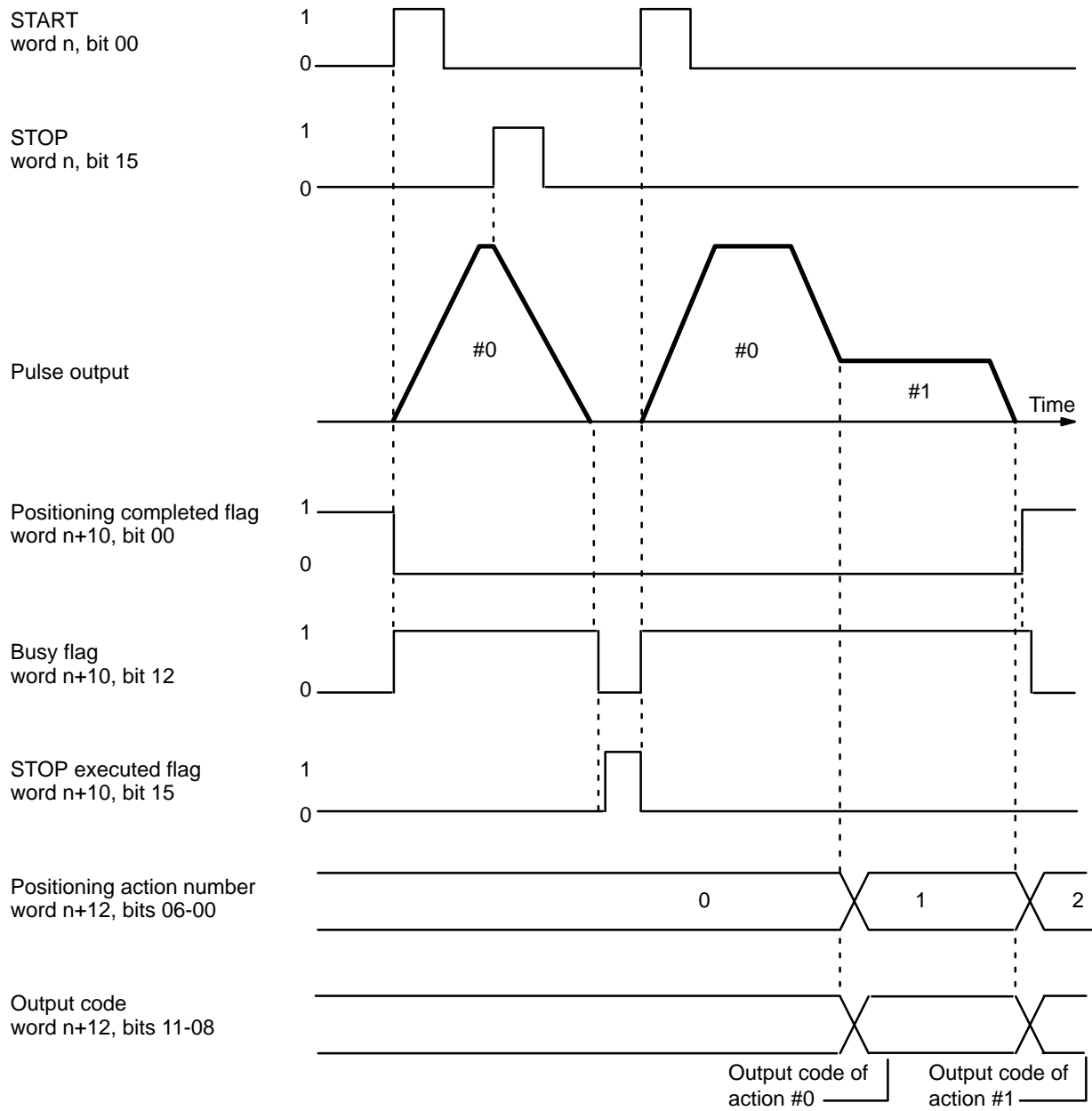

For interpolation, the operation is the same as above, even if the target position is expressed as relative positions on both axes.

Cautions for Using STOP during Interpolation

During interpolation, STOP is executed when the STOP executed flag of either the X or Y axis turns ON (X: bit 15 of word n+10; Y: bit 15 of word n+15). Restart via the X axis START command bit (bit 00 of word n). If restarting is executed via the Y axis START command bit (bit 00 of word n=5), positioning action is carried out for only the Y axis. Restarting uses the data in the same way as restarting a single axis.

Be aware that a restart when one axis is in an absolute position and the other is in an incremental (relative) position begins execution with the axes in those states (one axis absolute, the other incremental).

**X Axis: Relative Position
Y Axis: Absolute Position**

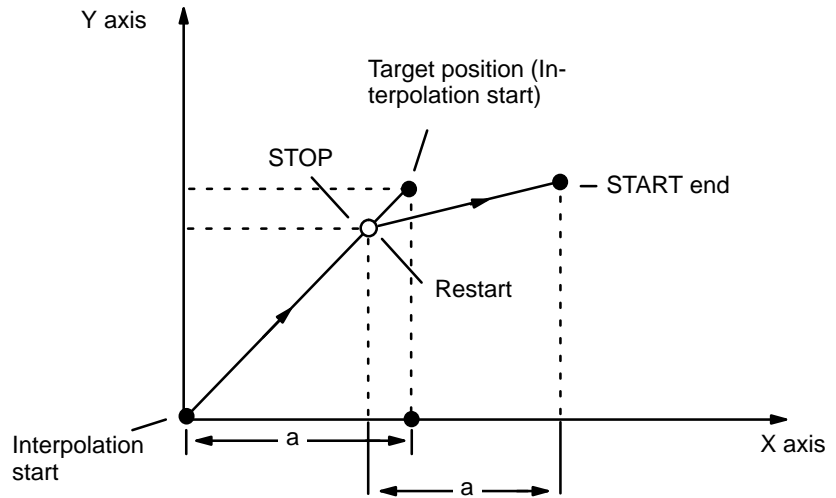

**X Axis: Absolute Position
Y Axis: Absolute Position**

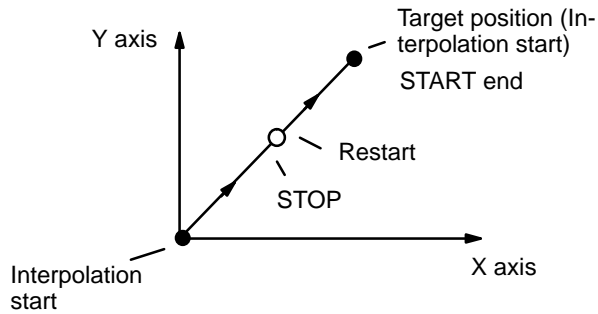

X Axis: Relative Position
Y Axis: Relative Position

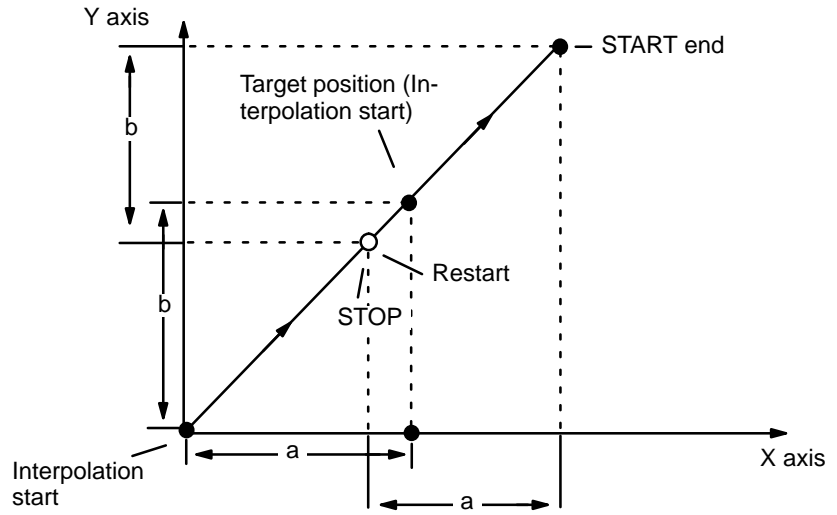

STOP During ORIGIN SEARCH

Feeding will be decelerated to a stop and the command must be reexecuted from the position reached at the end of STOP.

STOP During ORIGIN RETURN

Feeding stops according to the deceleration rate.

ORIGIN RETURN
word n, bit 03

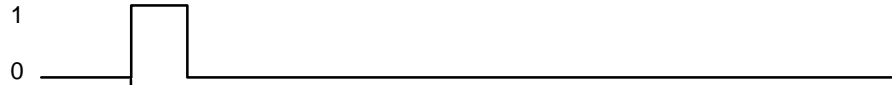

STOP
word n, bit 15



Pulse output

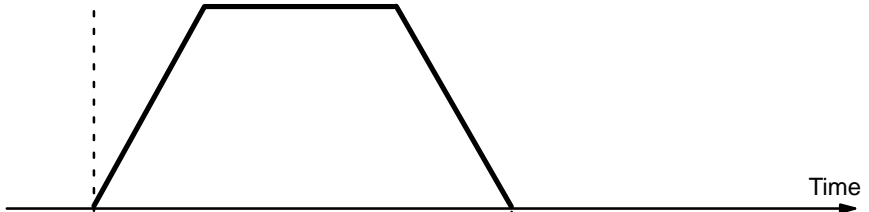

Busy flag
word n+10, bit 12

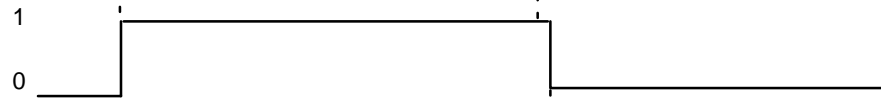

STOP executed flag
word n+10, bit 15



STOP During HIGH-SPEED JOG

If STOP is executed during HIGH-SPEED JOG, feeding will be stopped just as if the HIGH-SPEED JOG command bit (bit 11 of word n) were reset to ZERO. The command bit, however, will remain at ONE.

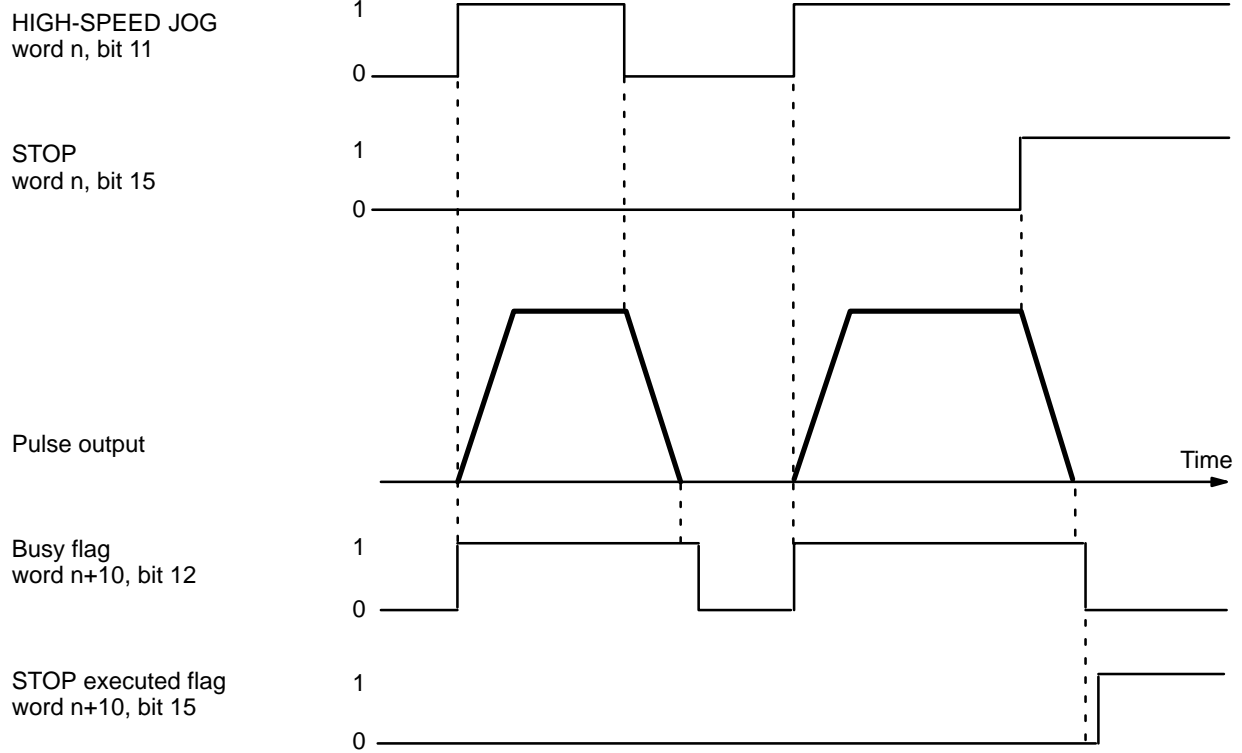

STOP During LOW-SPEED JOG

If STOP is executed during LOW-SPEED JOG, feeding will be stopped just as if the LOW-SPEED JOG command bit (bit 13 of word n) were reset to ZERO. The command bit, however, will remain at ONE.

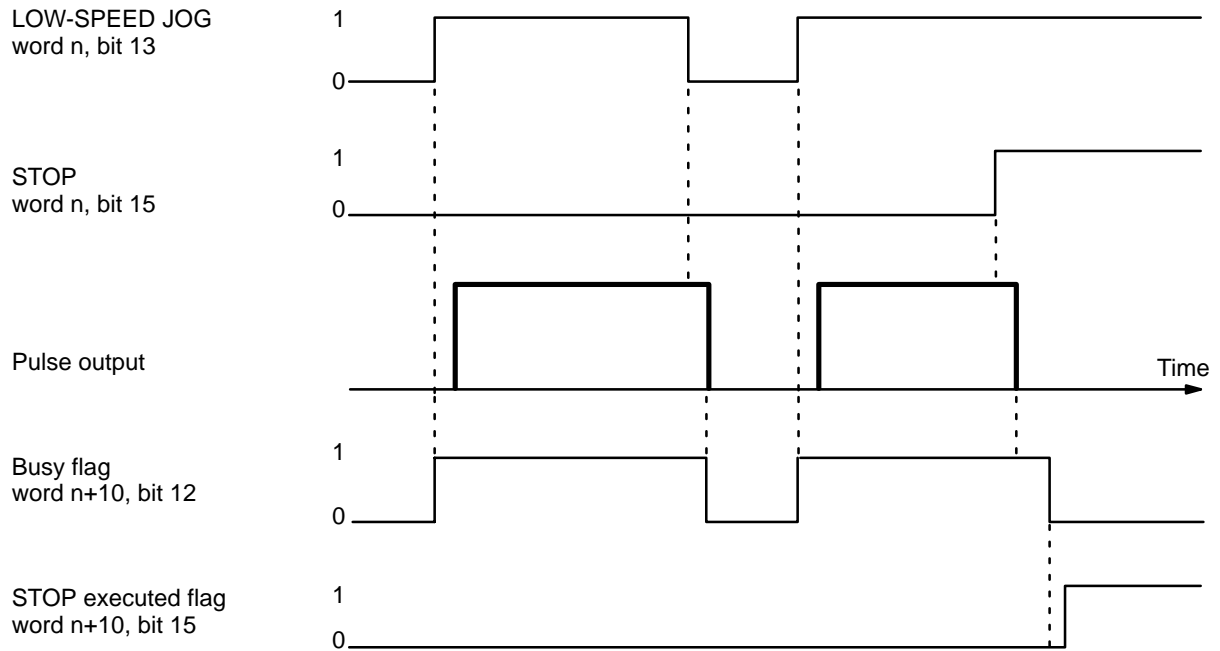

STOP During a Completion Code 5 Positioning Action

When STOP is executed for the first time during a positioning action with a completion code of 5, positioning will be executed according to whatever position data is set. When it is executed for a second time (see the example diagram on the following page), positioning is interrupted and decelerates to a stop.

Positioning cannot be restarted as long as the signal defined as the STOP command (either word n, bit 15 or an external interrupt signal) is ON, i.e., set to ONE. For details on defining either word n, bit 15 or an external interrupt signal as the STOP command, refer to DIP Switch Settings under 6-6 External Interrupt Commands.

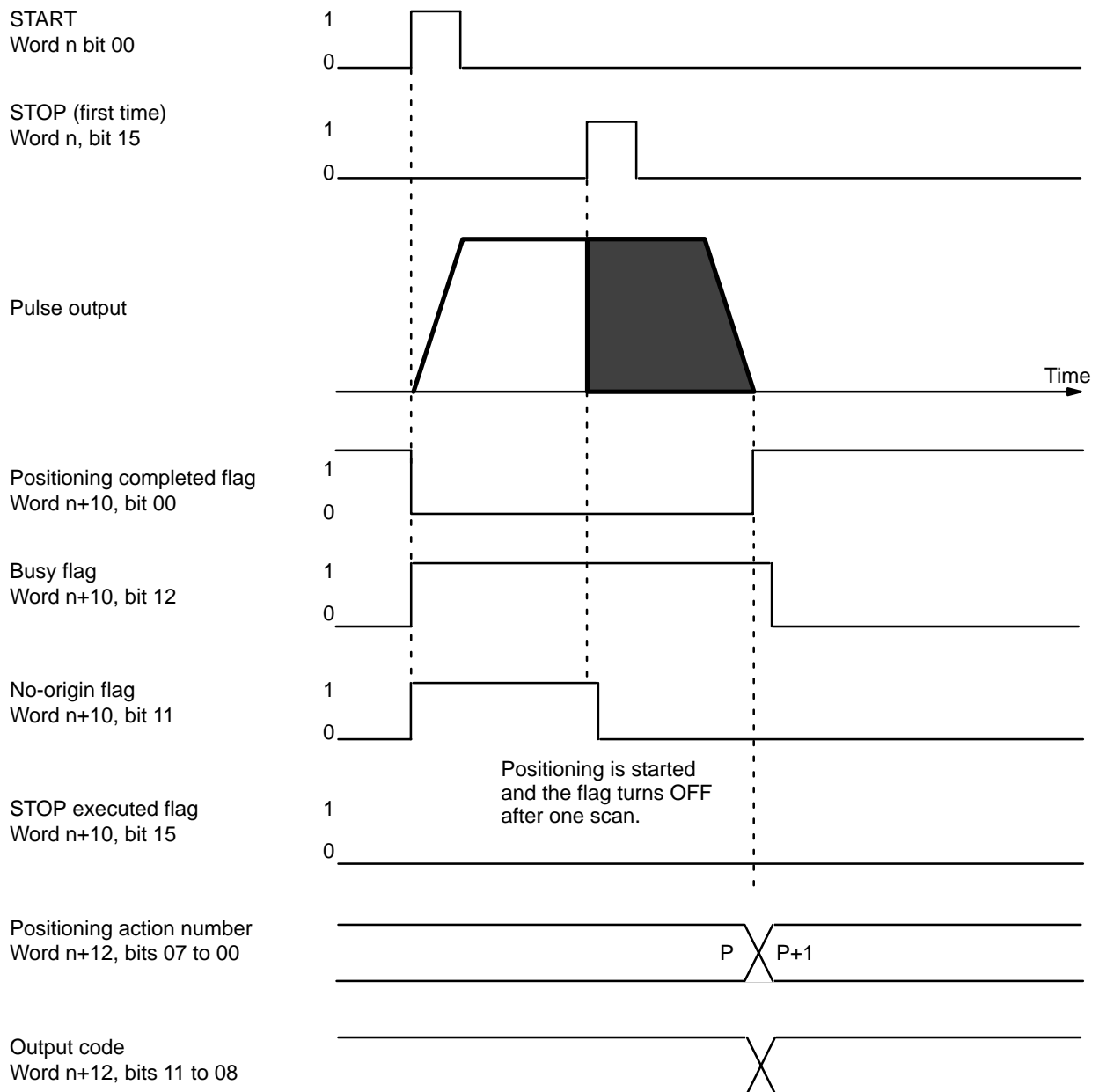

When STOP is executed for the second time, positioning is interrupted and deceleration comes to a stop.

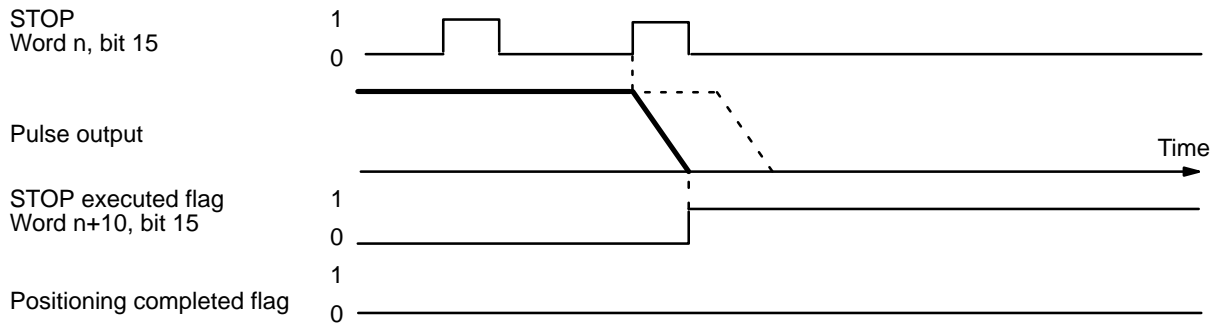

The positioning action number and output code will not be updated.

6-8 CHANGE SPEED

CHANGE SPEED can only be executed during positioning initiated with START. When executing CHANGE SPEED several times consecutively, you can either choose to have speed numbers incremented one by one, or select specific speed numbers to be executed in any order. Set the speed numbers in bits 05 to 00 of IR word n+2. (Refer to IR Area Settings and DIP Switch Settings under 6-6 External Interrupt Commands). If you set these bits to 00, the speed numbers will be incremented in order beginning with the one currently being executed. You can select specific speed numbers by setting the bits anywhere from 01 to 15.

It is also possible to execute CHANGE SPEED with bit 06 of IR word n, depending on the DIP switch settings. If bit 06 is used, the data will simultaneously be input to word n+2. With an external interrupt signal, however, you must input the data at least one scan before the scan in which it is to be used.

When the target position is being approached, CHANGE SPEED will not affect deceleration for that purpose. In other words, normal deceleration to end at the target position will be carried out for single, pause, or bank end positioning actions and the target speed for the next positioning action will take priority for a continuous positioning action.

Execution Example

In the following example diagram, speed number 1 is used for the positioning action executed first.

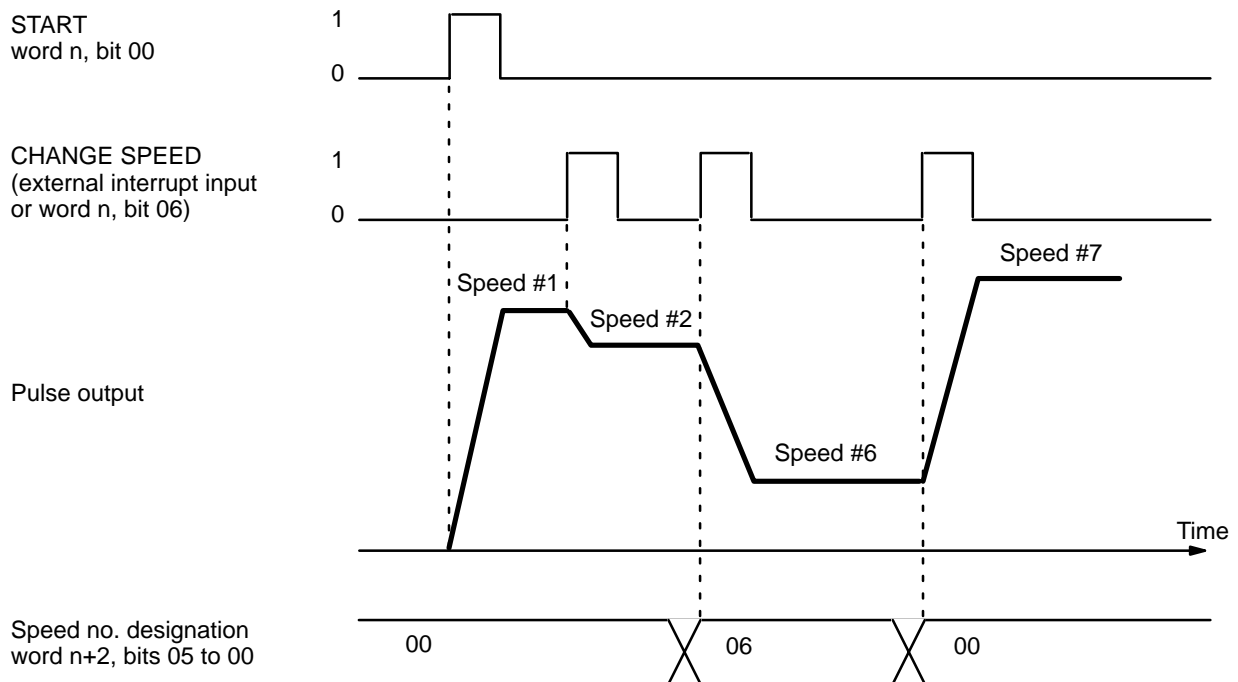

CHANGE SPEED is effective only for X axis commands. Y axis commands are ignored. X axis data becomes the interpolation data.

6-9 CHANGE SPEED COEFFICIENT

X: Bit 07 of word of word n+1
 Y: Bit 07 of word of word n+6

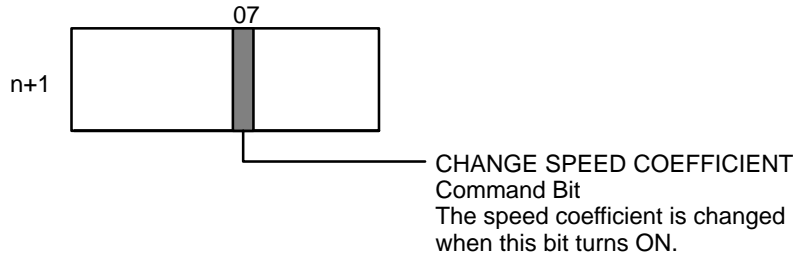

Used when the coefficient of the target speed is to be changed during positioning. After the coefficient is set in bits 05-00 of word n+2, this bit turns ON to change the speed coefficient. When START is executed with the valid speed coefficient bit ON, the coefficient set at that times is used without change. The CHANGE TARGET SPEED COEFFICIENT command cannot be executed within the same scan as START. If you want to use this command with START, be sure to turn this bit ON before executing START.

Operation of CHANGE SPEED COEFFICIENT Command

When the CHANGE SPEED COEFFICIENT command bit turns ON, all operations use the new coefficient. When the speed coefficient becomes invalid during operation (the coefficient becomes 1.0), set the value of the target speed coefficient to 0 or 10 and set the CHANGE SPEED COEFFICIENT command bit to ONE.

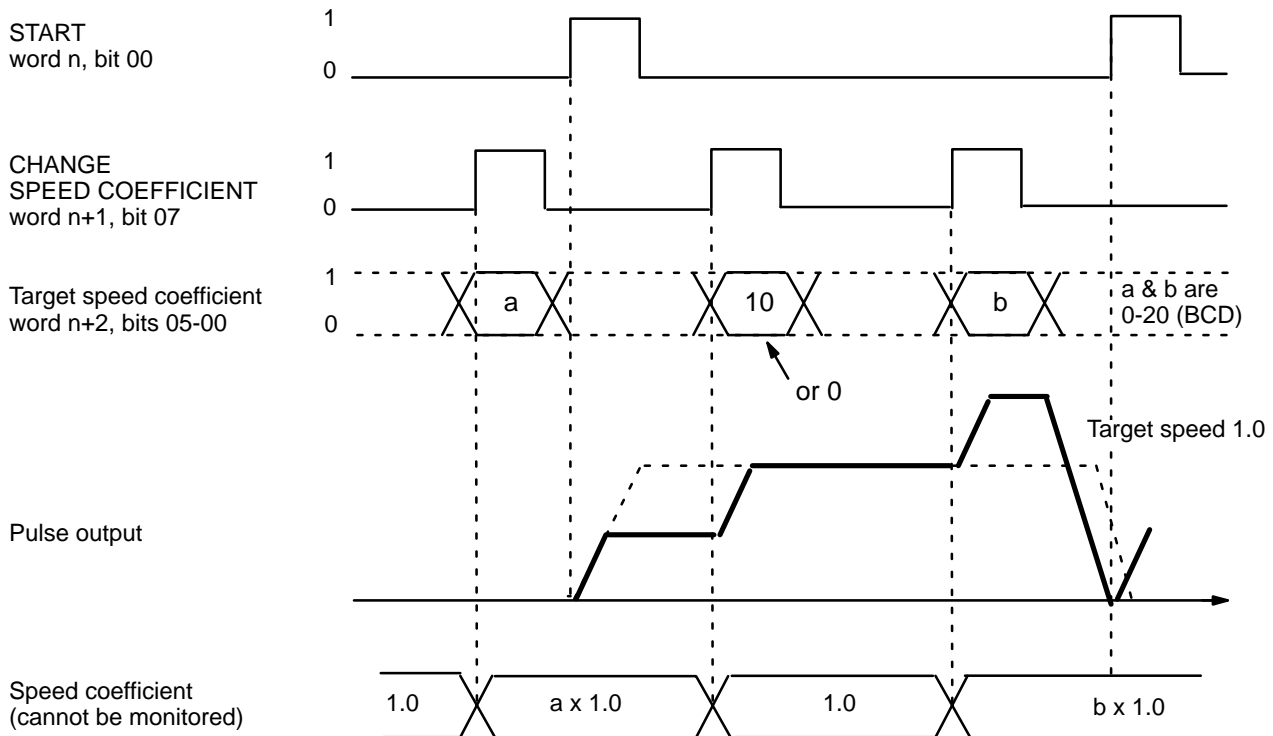

Operation of Valid Speed Coefficient

The valid target speed coefficient and the CHANGE SPEED COEFFICIENT command both use bits 05-00 of word n+2, but they operate independently. The valid speed coefficient applies a speed coefficient to the whole series of operations, while CHANGE SPEED COEFFICIENT is used to make changes in mid operation. Only the X axis flag turns ON during interpolation; the Y axis flag is ignored. The coefficient is applied to the interpolation target speed.

The valid target speed coefficient bit is either ONE or ZERO throughout operation. If this bit is ONE, the target speed coefficient is applied. The bit remains set until the next START command is executed.

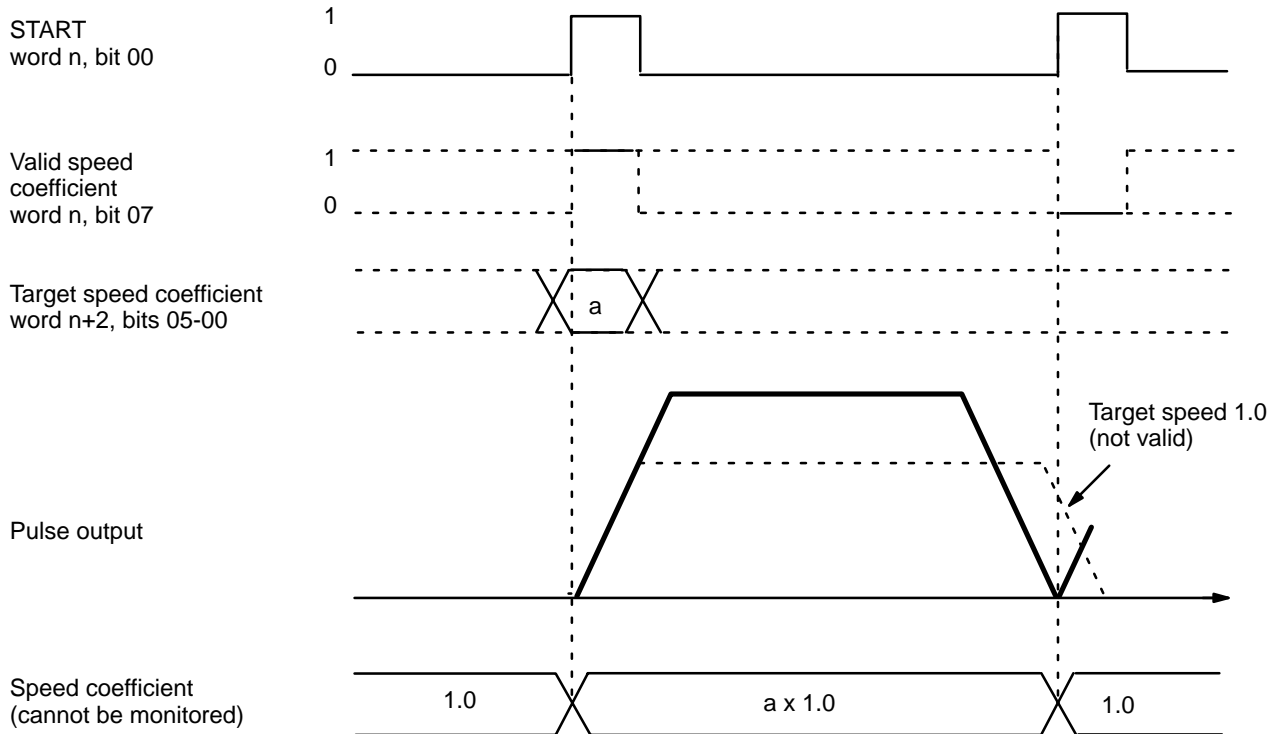

Combined Operation with START

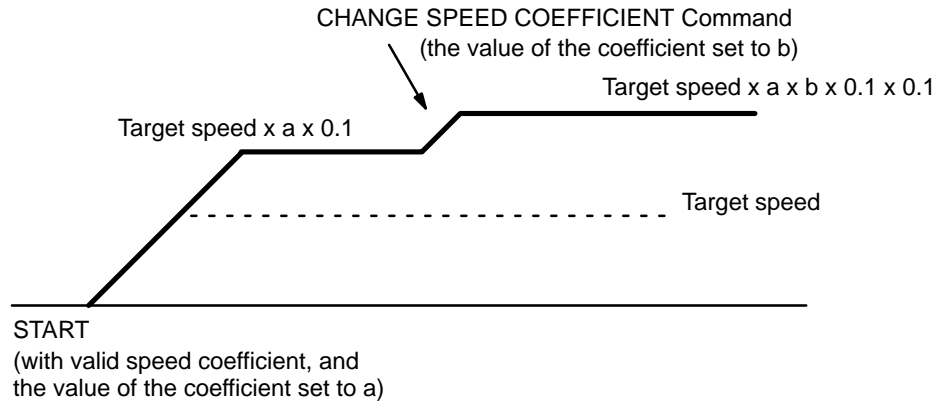

This example illustrates how the CHANGE SPEED COEFFICIENT command works with a valid target speed coefficient upon execution of START. Here the coefficient setting is 0 or 10. When CHANGE SPEED COEFFICIENT is executed, valid speed coefficient becomes invalid (the coefficient becomes 1.0). When setting the coefficient to 1.0, set bits 05-00 of word n+2 to 1/a (1/a will be an integer between 0 and 20), and then execute the CHANGE SPEED COEFFICIENT command.

SECTION 7

The TEACH Command

7-1	IR Area Settings	153
7-2	Execution Example	155
7-3	Teaching from the Programming Console	156
7-4	TRANSFER DATA	158
7-5	Present Position Preset	165

Section Overview

This section explains the TEACH command. When the origin and present position are defined (i.e., when the no-origin flag is OFF), you can use TEACH to write the present position as fixed data into the C200H PC's DM area available for use by Special I/O Units. Setting the TEACH command bit (bit 09 of word n for the X axis, bit 09 of word n+5 for the Y axis) writes the present position as the target position for the designated positioning action. Data are set as absolute positions rather than increments. TEACH can be executed within a single scan. The following diagram uses Unit #10 as an example and refers to the X axis. The case of the Y axis is the same.

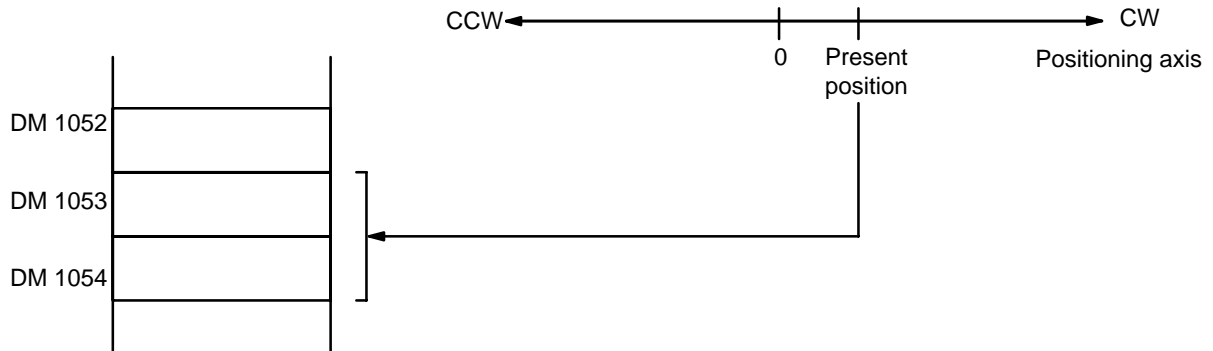

Data set using TEACH is valid immediately and can be used for positioning actions without turning off the power or transferring data. Note that data rewritten using the Programming Console is not valid until data has been transferred again.

7-1 IR Area Settings

In C200H PCs, IR words 100 to 199 are used for Special I/O Units. When a Position Control Unit is used, they are allocated as I/O refresh areas. For a detailed table of words and bits in the IR area, refer to Section 5-1 IR Area Allocations.

Present Position

When the no-origin flag is OFF, and pulse output is stopped at the position to be taught, the present position is set in words n+13 and n+14.

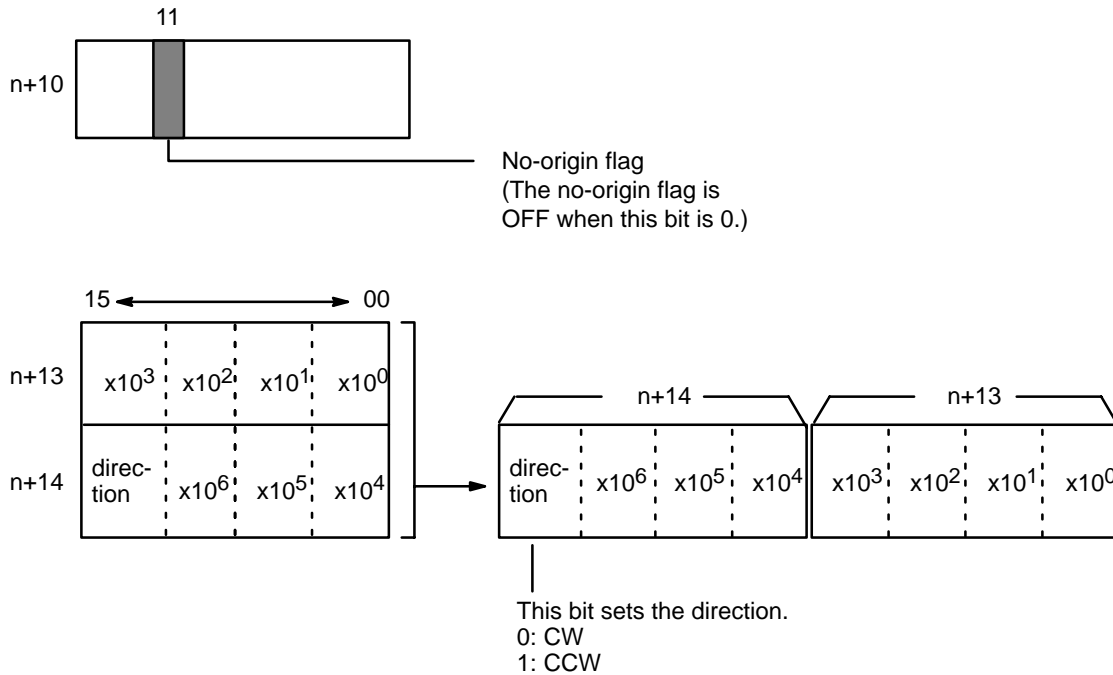

TEACH Positioning Action Number

X: Bits 15-08 of word n+1
Y: Bits 15-08 of word n+6

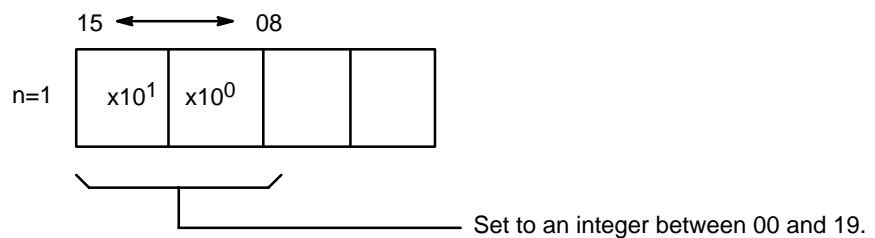

The number set here indicates the positioning action under START for which the present position is to be set as the target position.

TEACH Command Bit

X: Bit 09 of word n
Y: Bit 09 of word n+5

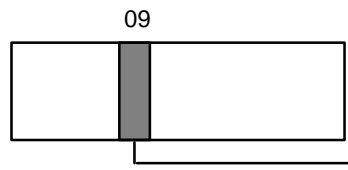

TEACH command bit
(TEACH begins at the
rising edge of this bit.)

When this bit turns ON, the settings it enables are effective in the same scan.

7-2 Execution Example

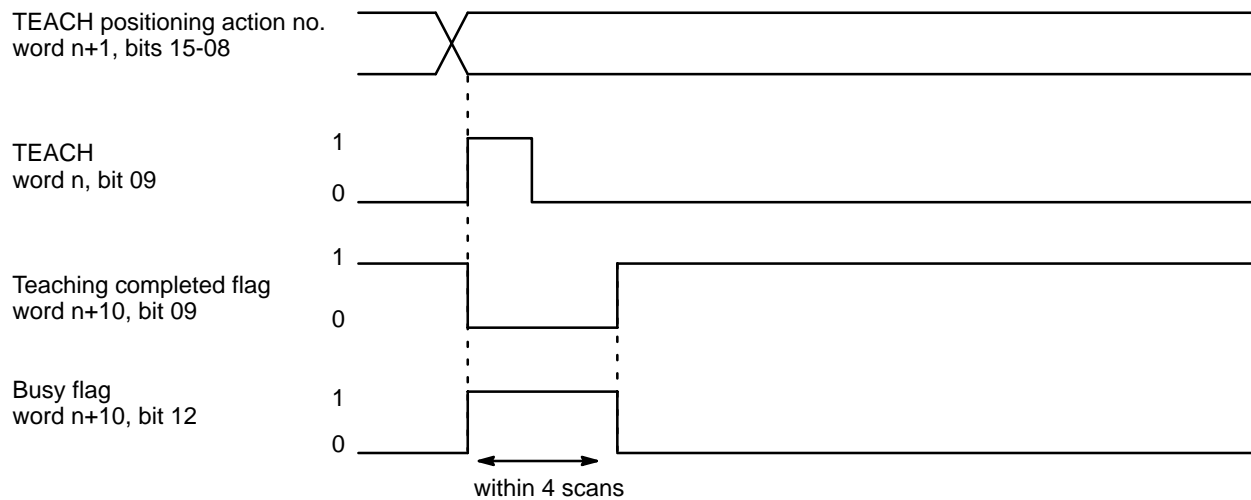

7-3 Teaching from the Programming Console

The following example shows how to teach positions from the Programming Console for Unit No. 0. It assumes that ORIGIN SEARCH has been executed, and writes the present position into words DM 1053 and 1054 as an absolute position (i.e., relative to the origin).

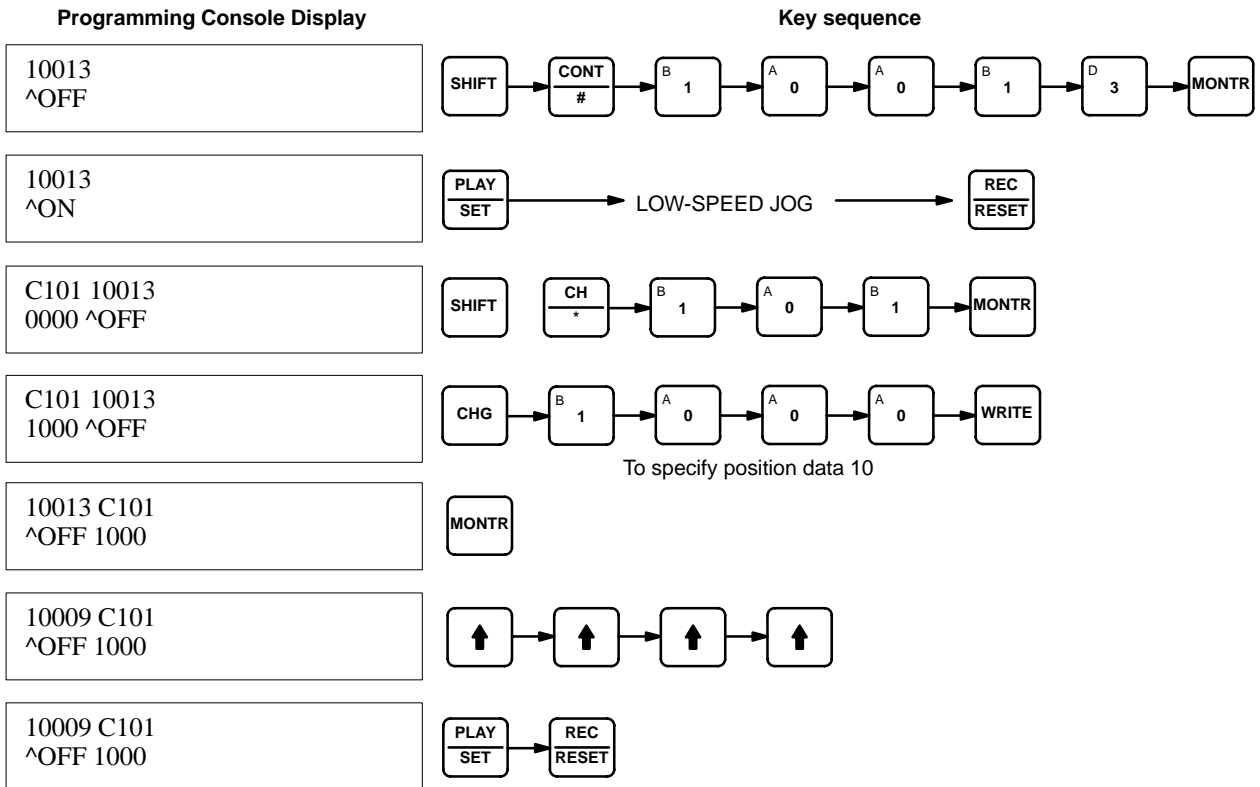

TEACHING From a Program

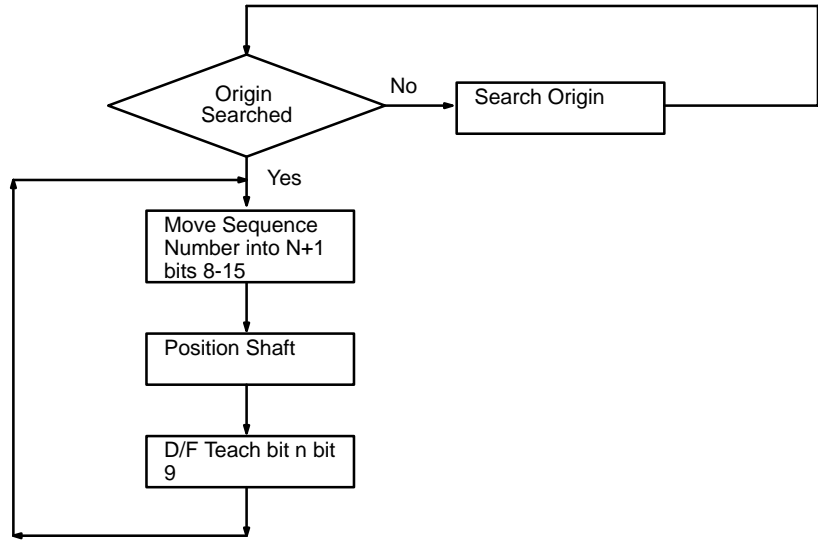

7-4 TRANSFER DATA

Use TRANSFER DATA when the set data automatically transferred from the C200H PC to the Position Control Unit is insufficient. Although only the data from the area designated for any particular Unit is automatically transferred when the Unit is powered up or restarted by the AR area restart bit, TRANSFER DATA can also be used to access data from any data area in the PC. In other words (as described in Section 3-2 Data Configuration and Allocation), Position Control Units are consecutively allocated 200 words each from the DM area, and this data is automatically transferred. TRANSFER DATA, however, can transfer data from other parts of the DM area, as well as from the LR, HR, and other areas. Transfer can take place during positioning actions. After transfer, the contents of the buffer must also be transferred. Be sure to execute transfer of buffer contents during a pause while in operating mode. Position, speed, acceleration, and deceleration data are all transferable. Transfer overwrites the RAM of the NC211, but does not affect the DM area in the C200H.

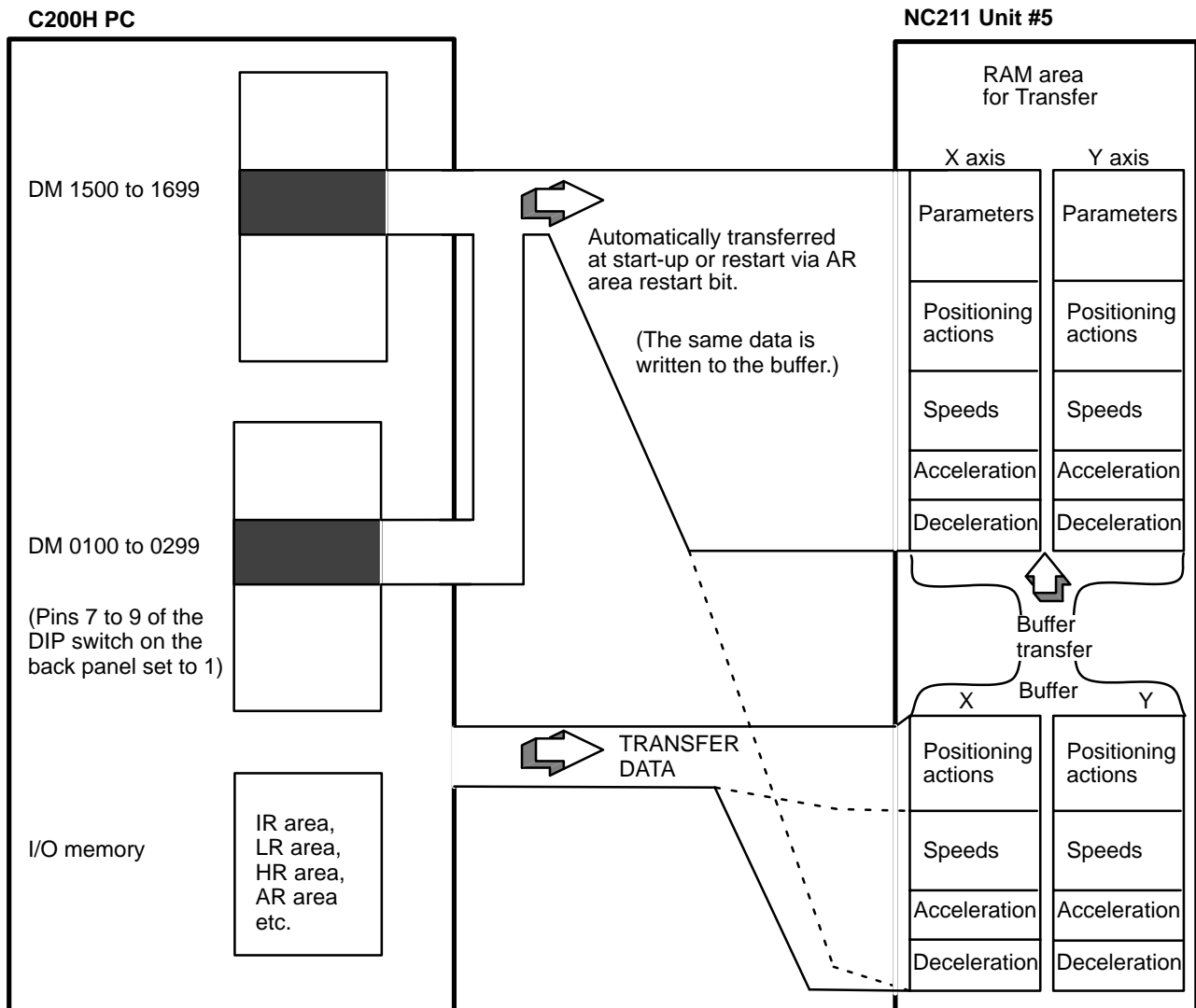

Note If expanded DM is not used, the data for speed, acceleration, and deceleration cannot be transferred with the data for positioning actions.

Normal Transfer

Positioning actions, speeds, acceleration, and deceleration can be transferred from a data area of the PC other than the one allocated to the Position Control Unit. Any data area in the C200H PC may be designated. This data is directly transferred from the designated area to memory within the Unit; the data set for the Unit in the allocated section of DM area is not affected. Parameters set in DM words m through m+21 are not changed when TRANSFER DATA is executed.

Data Preparation

Up to 26 transfers (three words each) can be made each time normal TRANSFER DATA is executed. Each transfer consists of one positioning action, three speeds, or speed units, acceleration, and deceleration. In any case, three words are required for each transfer. This data must be prepared in a PC data area in the required format and in consecutive words. (Refer to 3-3 DM Area Allocations for the content of each word/bit.) With data expansion, 59 transfers are possible.

PC Data Areas Available for TRANSFER DATA

Data Area	Words
DM area	0000 to 0999
DM area (for Special I/O Units)	1000 to 1999
I/O area	000 to 255
LR area	000 to 63
HR area	00 to 99
AR area	00 to 27

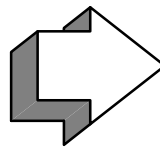

Position Control Unit's Rewritten Data

Transfer #0	Positioning action #0
Transfer #1	Positioning action #1
↓	↓
Transfer #19	Positioning action #19
Transfer #53	Speed #1 Speed #2 Speed #3
Transfer #54	Speed #4 Speed #5 Speed #6
↓	↓
Transfer #57	Speed #13 Speed #14 Speed #15
Transfer #58	Speed units Acceleration Deceleration

Positioning Action Data Expansion

Transfer #20	Positioning action #20
↓	↓
Transfer #52	Positioning action #52

Data Transfer Time

When executing TRANSFER DATA, the transfer completed flag (bit 10 of word n+12) will be OFF during data transfer and processing for the following period:

A maximum of $0.2 \text{ s} + k$ (scan time)

The value of k depends on the number of transfers being made, as illustrated in the following table. (When transferring data for both axes simultaneously, add the two k values.)

Number of transfers	k
1 to 6	1
7 to 13	2
14 to 20	3
21 to 27	4
28 to 34	5
35 to 41	6
42 to 48	7
49 to 55	8
56 to 59	9

Influence on PC Scan Time

Mounting one Position Control Unit on a PC extends the PC's scan time by about 7 ms. In addition, when transferring data, the scan time during which data is transferred increases by another 5 ms. For example, to transfer all 52 positioning actions, TRANSFER DATA only needs to be executed once, but both the PC and Position Control Unit require eight scans. Each of these scan times will be 5 ms longer than the normal scan time.

PC Data Area

X: Bits 07-00 of word n+4
 Y: Bits 07-00 of word n+9

This is the first word in the PC data area that is to be transferred into the Position Control Unit beginning at the transfer number designated above. The beginning word and ending word (computed from the number of transfers) must be within one of the data areas designated during data preparation.

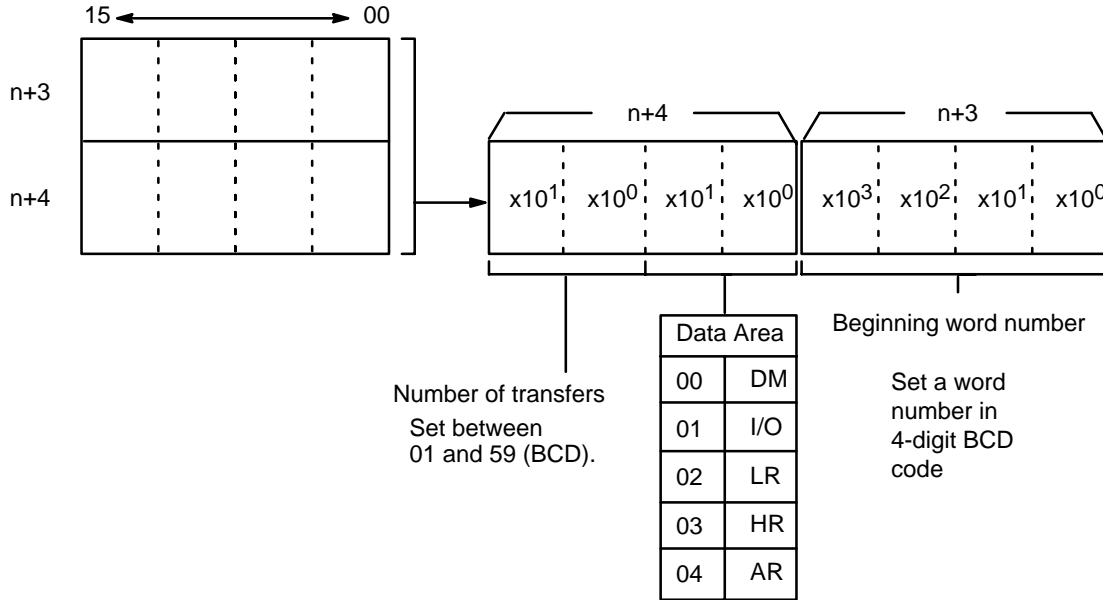

If expanded DM is not used, the data for speed, acceleration, and deceleration (transfer data #53-58) cannot be transferred with the data for positioning action (transfer data # 0-19). In that case, be sure to transfer the data separately.

TRANSFER DATA Command Bit

X: Bit 10 of word n
 Y: Bit 10 of word n+5

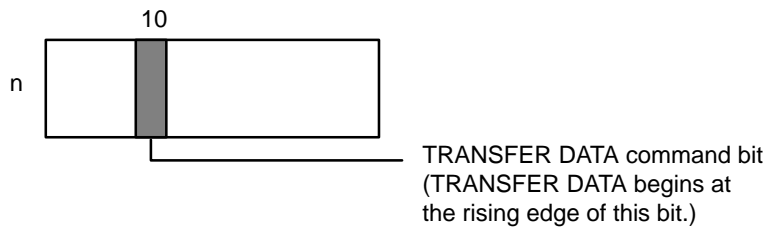

When this bit turns ON, the settings it enables are effective in the same scan.

Transfer buffer Command Bit

X: Bit 15 of word n+1
 Y: Bit 15 of word n+6

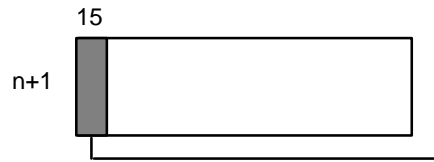

transfer buffer command bit
 (After TRANSFER DATA has been executed, Transfer buffer begins at the rising edge of this bit)

If the contents of the buffer are not transferred after TRANSFER DATA has been executed, the positioning action data contained in the buffer is lost. Be sure to execute Transfer buffer after TRANSFER DATA is completed and positioning stopped, but while the PC is in RUN mode. TRANSFER DATA can be executed repeatedly before executing Transfer buffer. For example, if partial transfers of positioning action and speed data have been made, a single execution of transfer buffer is adequate. Because all data in the buffer is transferred to the memory area of the PC200H, words n+2 through n+4 do not need to be set when transfer buffer is executed. Transfer buffer does not alter the contents of the buffer.

**Execution Example
(Normal Transfer)**

This example assumes that bit 15 of word n+2 is ZERO.

Preparation of data
in PC's data areas



Set necessary information in IR area.

Beginning transfer number
word n+2, bits 14-08

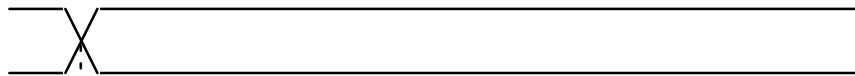

Beginning word number
word n+3



PC data area/no. of transfers
word n+4

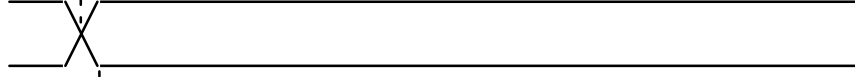

TRANSFER DATA
word n, bit 10

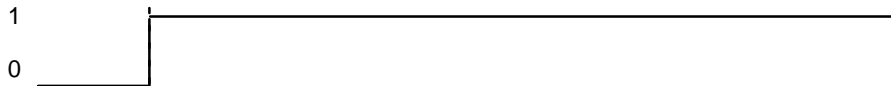

Transfer completed flag
word n+10, bit 10

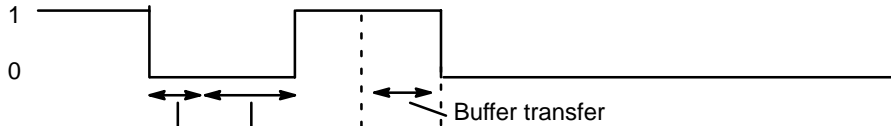

Transfer buffer
word n+1, bit 15

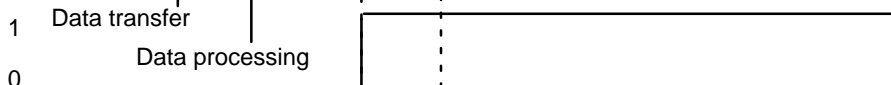

Busy flag
word n+10, bit 12

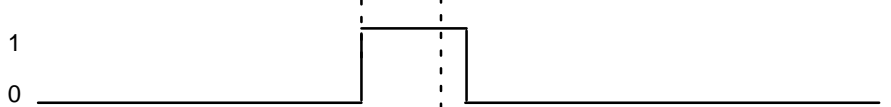

After transfer buffer has been completed,
the busy flag turns off.

TRANSFER DATA can be executed whether the busy flag is ON or OFF. The TRANSFER DATA command bit and transfer completed flag do not affect the busy flag. The transfer buffer is disabled while the busy flag is ON. Do not attempt to execute transfer buffer while TRANSFER DATA is being executed. Do not attempt to execute TRANSFER DATA while transfer buffer is being executed.

7-5 Present Position Preset

If bit 15 of word n+2 is ONE, setting the TRANSFER DATA command bit (bit 10 of word n) either presets or changes the present position. This command eliminates the need to execute ORIGIN SEARCH to establish position. Because the origin and present position are unknown when the Unit is powered up, ORIGIN SEARCH must normally be executed before any positioning action. However, when you want to know the absolute position and set a particular numerical value, use present position preset. You can also use the preset function to change the present position.

Retaining Present Position

No data is retained in the Position Control Unit after power is turned OFF. If the present position needs to be retained, copy it (words n+13 and n+14) to either the HR or DM area; it can then be restored by executing TRANSFER DATA the next time the Unit is powered up.

The following programming example shows word n+13 data being sent to word HR 00 and word n+14 data to word HR 01. If there is no origin, bit 11 of word n+10 (the no-origin flag) turns ON. As long as there is an origin and the present position data is valid, the present position will be transferred. Be sure to execute DATA TRANSFER for present position preset during a pause, but while the PC Unit is in operating mode.

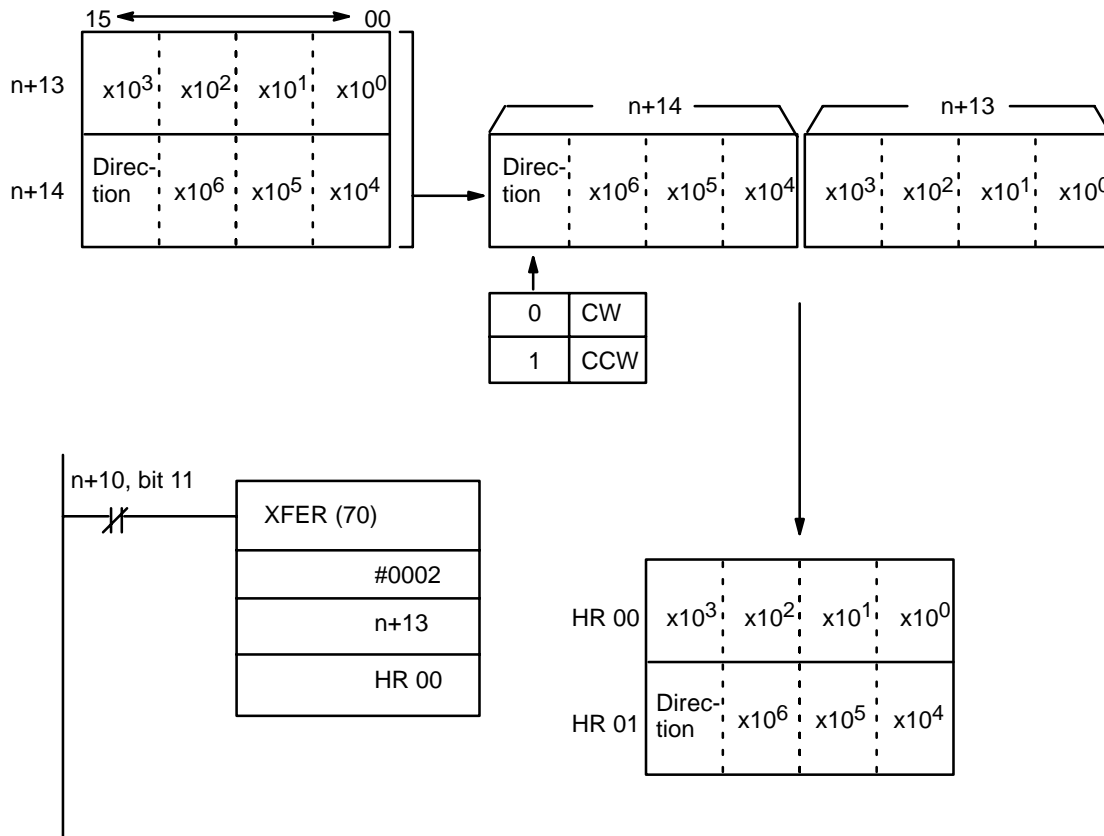

Data Preparation

Data must be prepared in the same manner as for normal execution of TRANSFER DATA, except that only two words indicating the target position are required (number of transfers need not be set). Execution of transfer buffer is unnecessary after present position preset.

Present Position Preset Bit

X: Bit 15 of word n+2
 Y: Bit 15 of word n+7

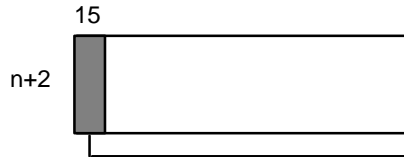

Present position preset bit
 When this bit is 1, present position preset is set.

Set this bit to ONE to use the preset function. If this bit is set to ZERO, the beginning transfer number is set in bits 15-08 as described in Beginning Word Number under Section 7-4 IR Area Settings.

Beginning Word Number

X: Word n+3/bits 07-00 of word n+4
 Y: Word n+8/bits 07-00 of word n+9

Set the data area in BCD from which the transfer is to be made.

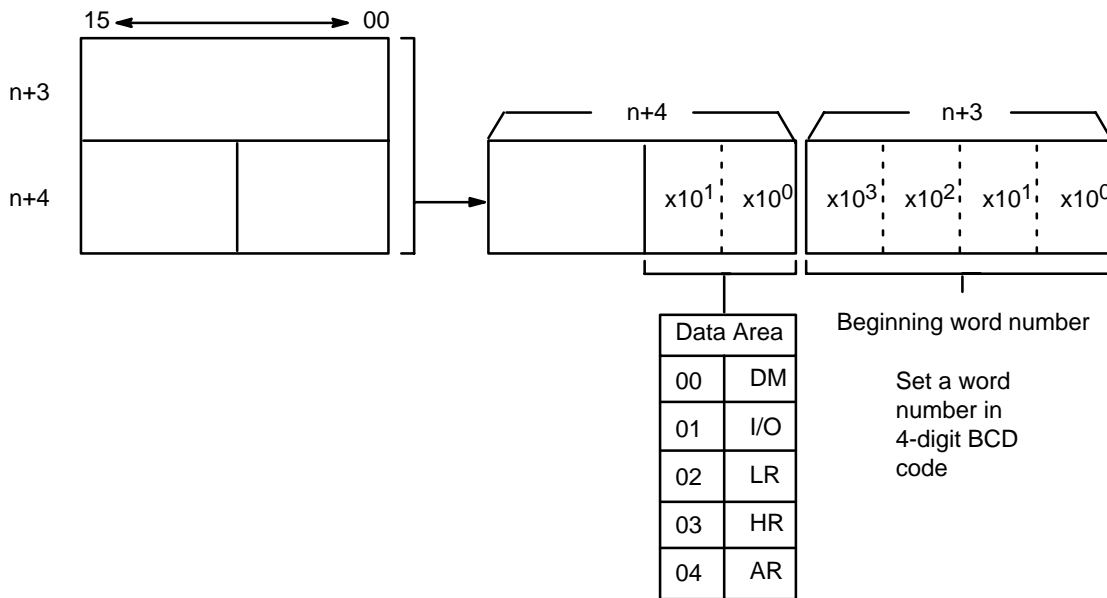

This number indicates the first of the two words to be transferred as the present position. The two words must be within one of the data areas designated for Data Preparation under Section 7-4 Transfer Data.

PC Data Area

X: Word n+3/bits 07-00 of word n+4

Y: Word n+8/bits 07-00 of word n+9

Set the data area (in four digits BCD) from which the transfer is to be made.

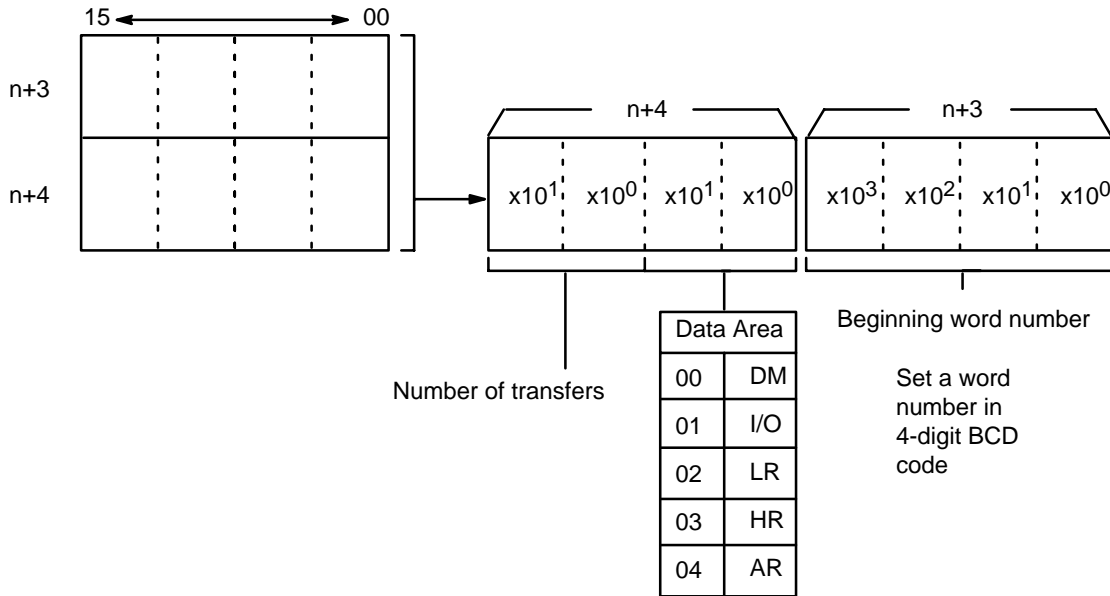

Here the number of transfers is fixed at 2 words, and no setting needs to be made for transfer quantity.

TRANSFER DATA Command Bit

The TRANSFER DATA command bit setting is the same as described previously for normal transfer under Section 7-4 IR Area Settings.

Execution Example (Preset)

The following example assumes that bit 15 of word n+2 has been set to ONE.

Set necessary information in IR area.

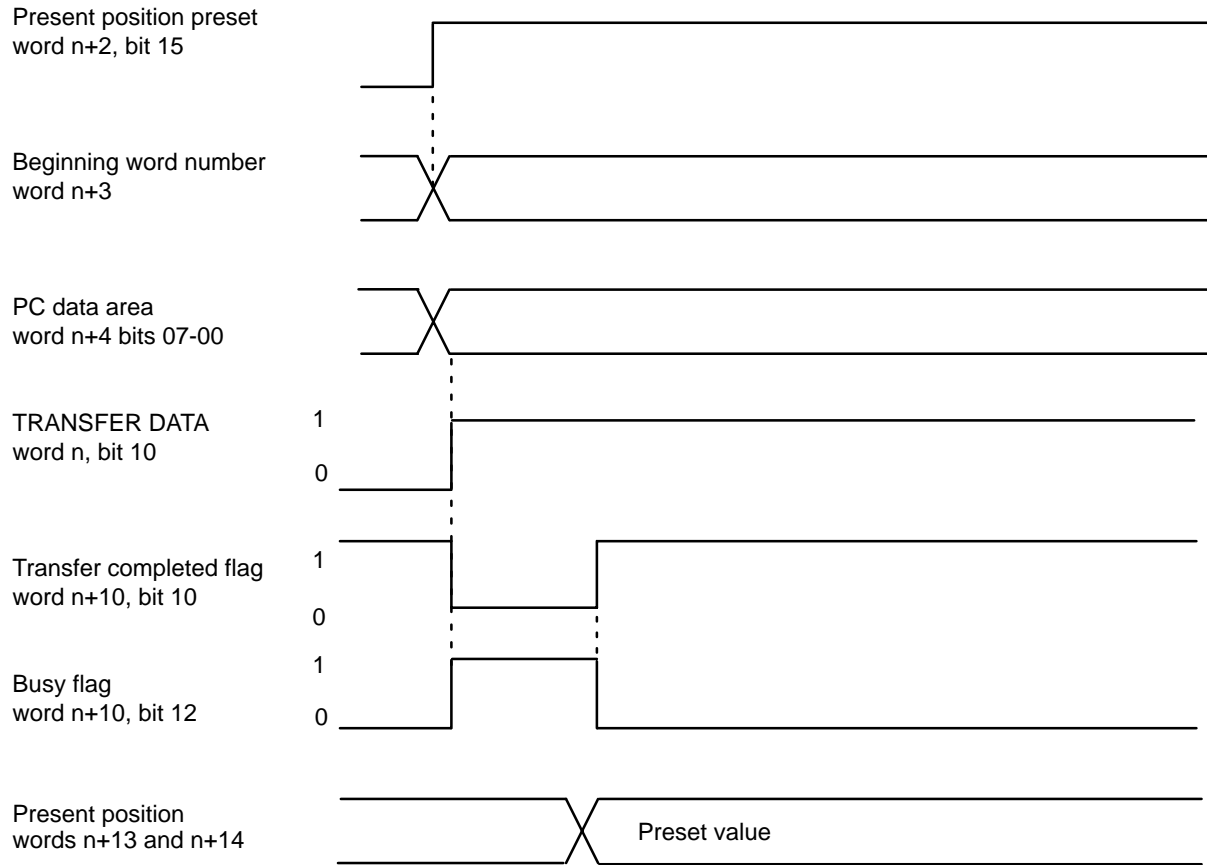

TRANSFER DATA cannot be executed for present position preset when the busy flag is OFF.

SECTION 8

Error Processing

8-1	Alarms and Errors	170
8-2	Alarm/Error Indicators	172
8-3	RELEASE PROHIBIT	173
8-4	READ ERROR	176
8-5	Troubleshooting from the PC	179
8-6	Detection of Abnormal Pulse Outputs	181
8-7	Alarm Code List	183
8-8	Error Code List	185

Section Overview

This section presents information about Alarms, Errors, and troubleshooting. It explains what to do when errors occur and how to avoid errors before they happen. The end of this section presents a complete list of Alarm Codes and Error Codes.

8-1 Alarms and Errors

Alarms

Whenever the Position Control Unit is powered up, or data is transferred into the Unit, checks are performed to ensure that the data is in the proper form and can be used for operation. If an error exists in speed or positioning action data at this time, an alarm code is generated. Errors that result in alarms include BCD errors, out-of-range data, and no-data errors (when required data is set at 0). An alarm will thus be generated, for example, if the required settings are not made in the DM area of the PC. Operation can be continued even after an alarm has been generated, however, as long as the data that generated the alarm is not used.

Errors

If operation is attempted with data for which an alarm has been generated, an error code will be generated and further operation will not be possible. Error codes can also be generated during pulse output, e.g., when an emergency stop results from CW limit input.

Relationship between Alarms and Errors

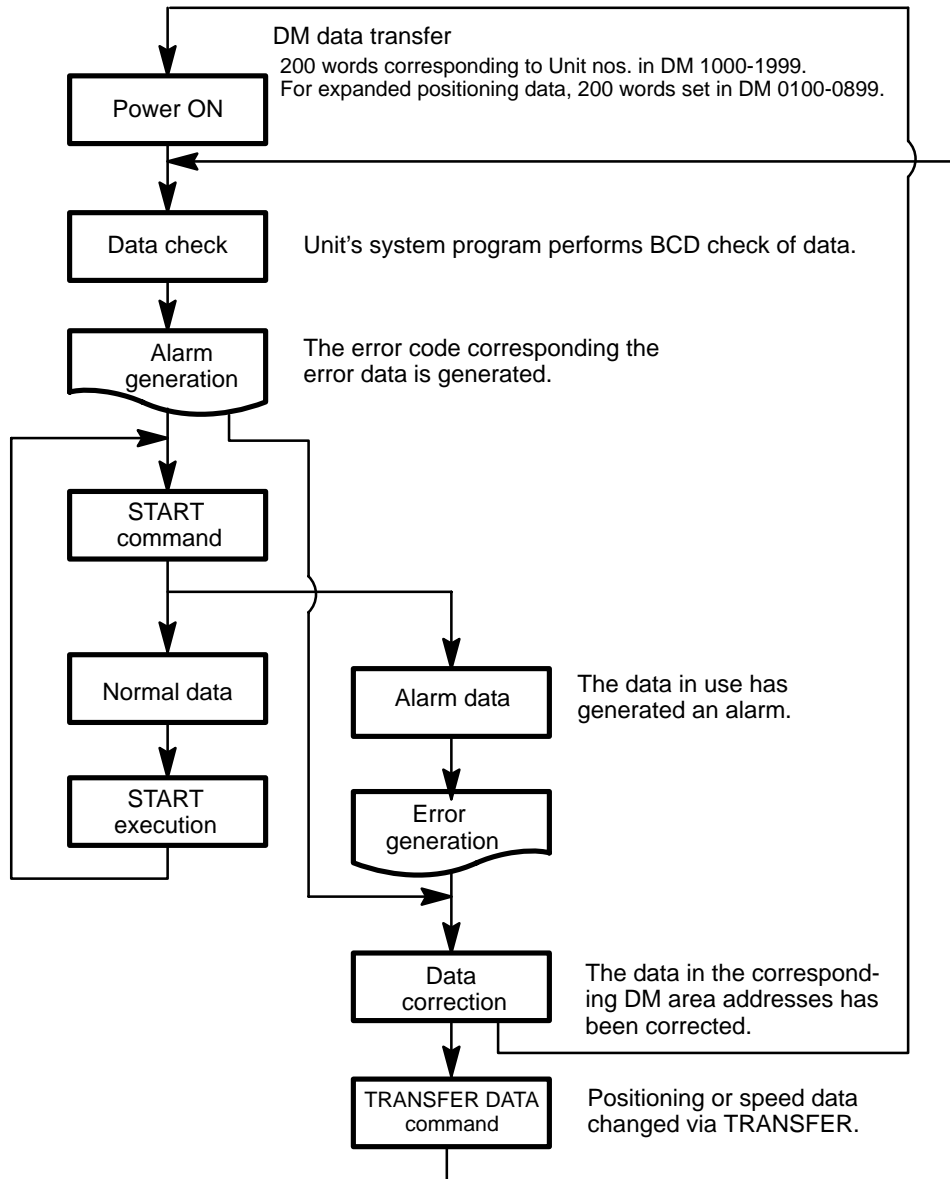

8-2 Alarm/Error Indicators

The existence of an alarm or error code is indicated both by the alarm/error LED on the front panel (see figure below) and by the flags (see above) in the IR area of the PC.

Front Panel LED

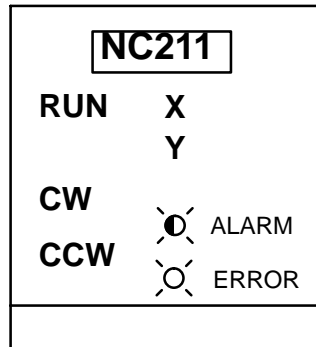

ALARM indicator flashes when an alarm code has been output and the ERROR indicator lights when an error has occurred.

Outputs to the IR Area

Twenty words from DM 100-199 allocated for each Unit number.

Alarm Flag

X: Bit 03 of word n+10
Y: Bit 03 of word n+15

Error flag

X: Bit 05 of word n+10
Y: Bit 05 of word n+15

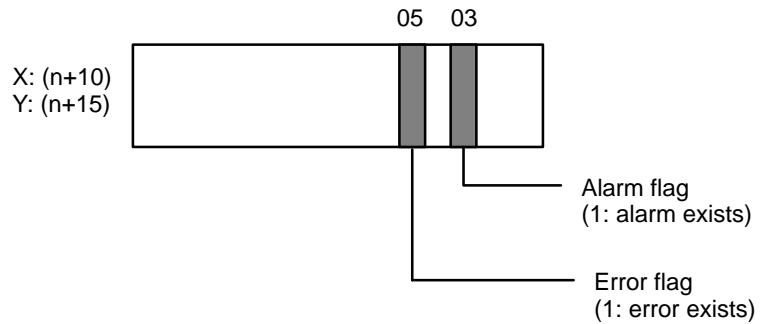

8-3 RELEASE PROHIBIT

When Position Control Unit operation is stopped as a result of input of an emergency stop, CW limit, or CCW limit signal, (i.e., when the N.C. input of any of these turns ON), further pulse output is prohibited. In order to resume pulse output, it is necessary to cancel this prohibition by means of the RELEASE PROHIBIT command bit (bit 04 of word n) and release of the external emergency stop switch.

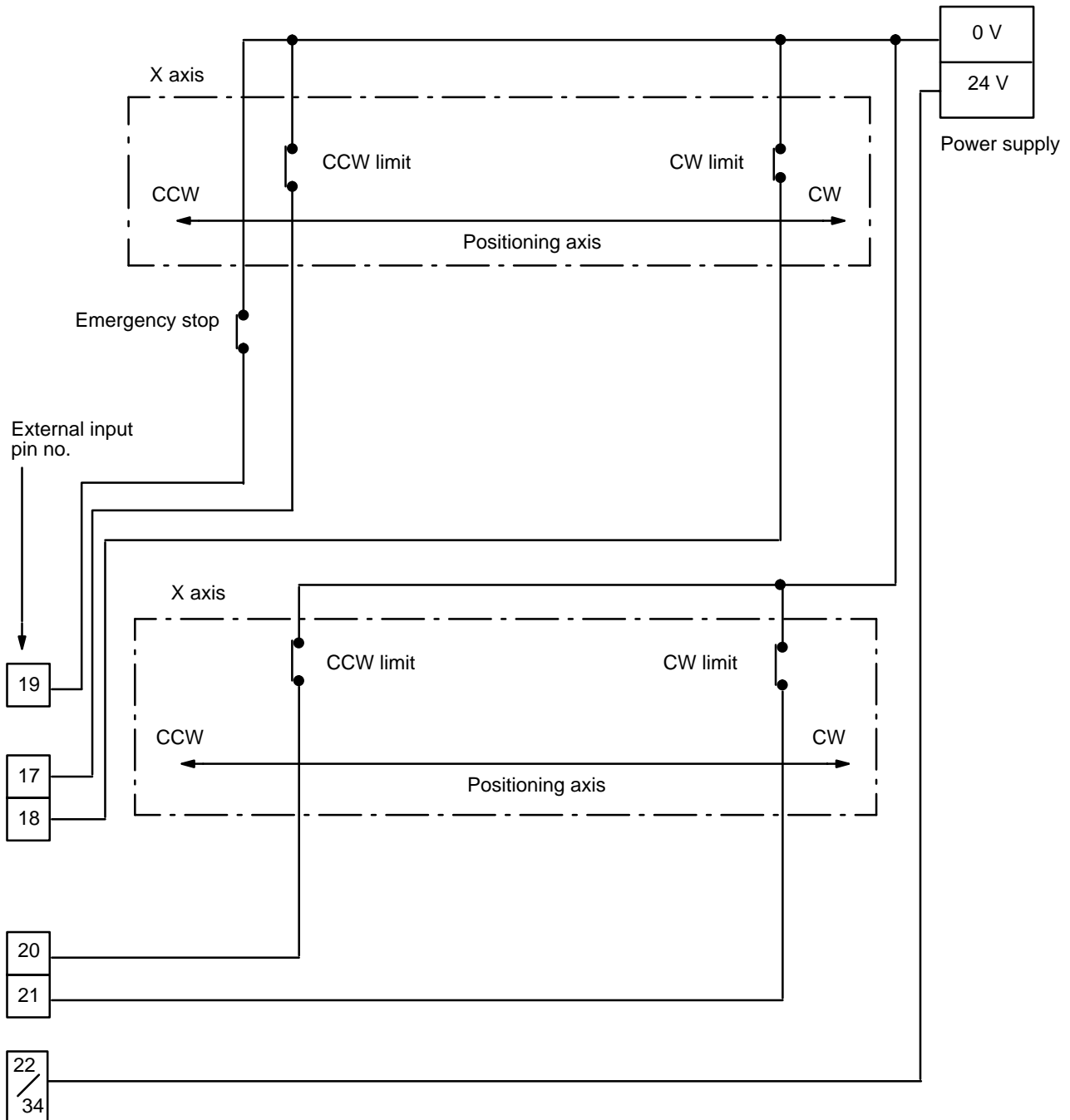

Execution Examples

Example 1: Emergency Stop

The present position is lost during an emergency stop, and positioning cannot be started again directly after RELEASE PROHIBIT. Execute ORIGIN SEARCH before proceeding. Although the following explanation is made with respect to the X axis, the case of the Y axis is essentially the same. The error flag is turned OFF after executing the ORIGIN SEARCH.

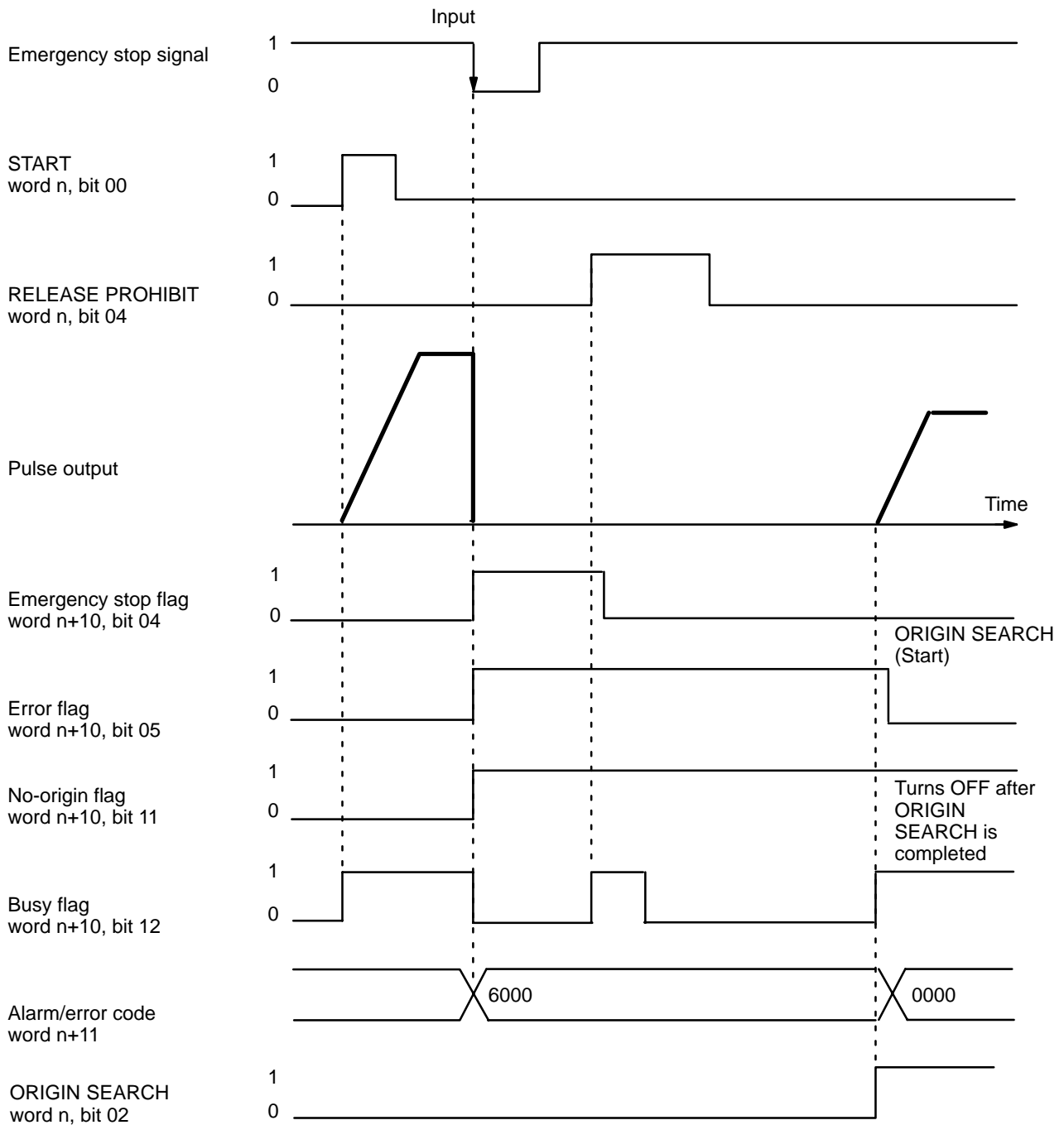

Example 2: Exceeding CW or CCW Limit

The emergency stop flag is not affected by exceeding the CW or CCW limit. If a limit is exceeded, pulse output is possible in the opposite direction only. The CW limit is exceeded here, so only CCW output is possible. This example uses JOG to clear the limit flag, but ORIGIN SEARCH may also be used.

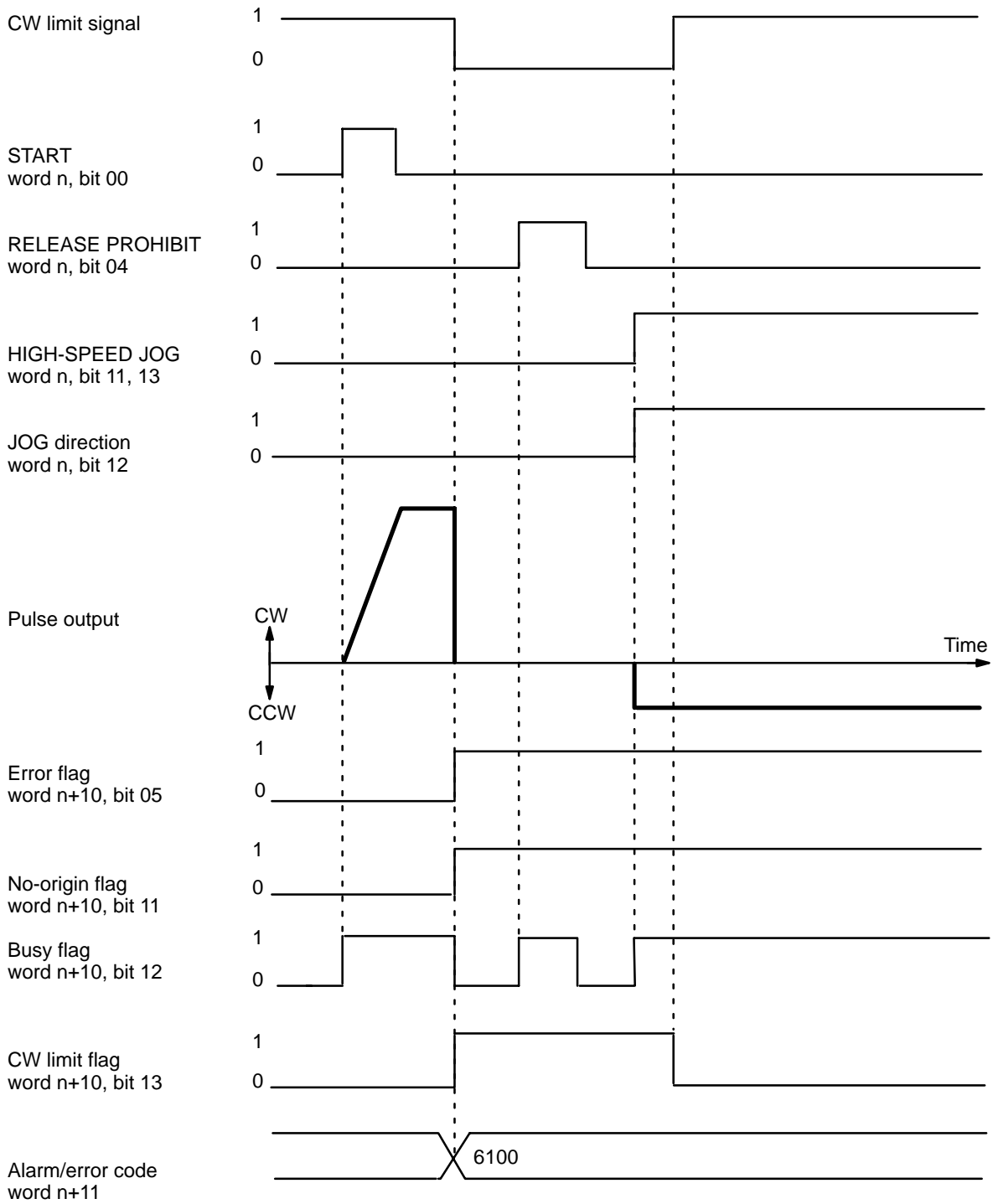

8-4 READ ERROR

The READ ERROR command bit, bit 05 of word n, is set to access error and alarm codes when more than one of these is present (effective on the signal's rising edge).

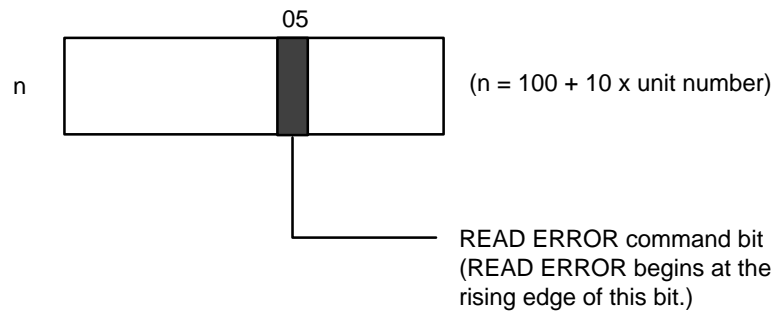

The codes are consecutively output to word n+10. Errors and alarms have separate flags, as follows:

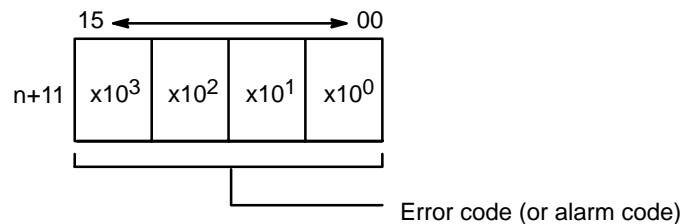
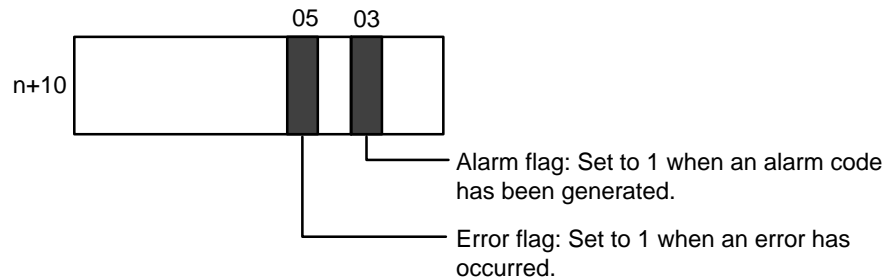

Word n+11 shows four digits in BCD when displayed on the Programming Console. If there are no errors or alarms, 0000 will be displayed. If there are any errors or alarms, they will be displayed in code. The codes will be displayed in order as READ ERROR is executed. (If there is only one code, however, the display will not change when READ ERROR is executed.)

The error or alarm code (word n+11) is updated via I/O refreshing immediately after the READ ERROR command bit is turned ON. The busy flag does not turn ON. READ ERROR can be used within a signal scan.

Execution Example

The following diagram shows an example in which first the alarm code 1501 and then the error code 5000 are displayed.

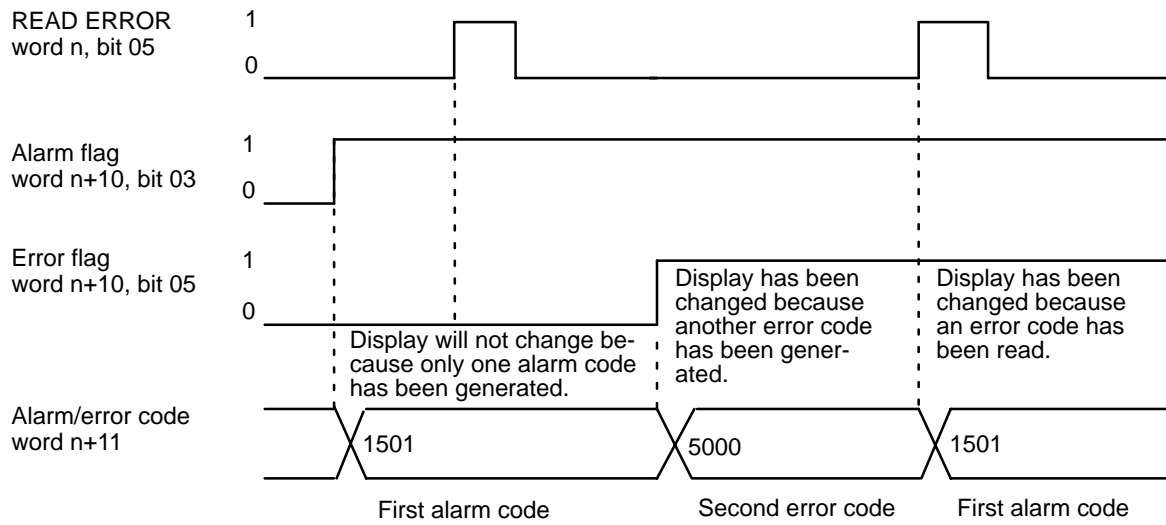

Note When either axis is in the middle of data transfer or when the busy flag is turned ON, error codes are not accessed correctly from the data buffer. In such cases, the above example does not apply.

Reading from the Programming Console

The following example diagram (for Unit #1) shows how to read an alarm/error code from the Programming Console.

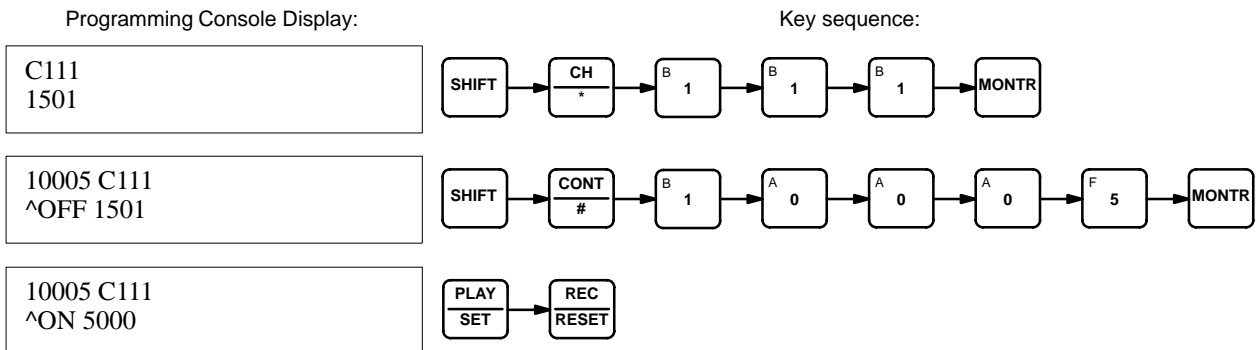

Alarm/Error Codes

X: Word n+11

Y: Word n+16

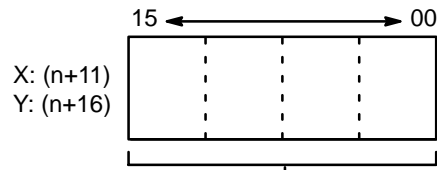

Error code (or alarm code)

Generally, a new error (or alarm) outputs a single error code. When the error output bit turns ON, multiple error or alarm codes can be read sequentially.

This word contains only the most recent alarm or error code. Several error codes can be read out in sequence by setting the READ ERROR command bit (X: bit 05 of word n; Y: bit 05 of word n+5). Refer to Section 8-4 READ ERROR.

8-5 Troubleshooting from the PC

Abnormalities in the Position Control Unit can be monitored from the C200H PC. The C200H PC is monitored as a Special I/O Unit, and as such is treated in the same as a High-Speed Counter.

Error List for Special I/O Units

Error	Causes of Abnormality and Operating Status	Correction
Waiting for Special I/O Unit start-up.	Special I/O Unit has a hardware malfunction. PC will not begin operation.	Replace the abnormal Special I/O Unit with a new Unit. (The abnormal Unit displays only "\$" when the I/O table is read.)
Too many Special I/O Units.	Same unit number has been assigned to more than one Special I/O Unit. PC will not begin operation. SR bit 25415 is ON.	Set unit numbers so that each is used only once. (Unit numbers can be accessed by reading the I/O table.)
Error in Special I/O Unit.	Refreshing between the CPU and the Special I/O Unit was not executed correctly. Only the abnormal Unit will stop operating. SR bit 25415 is ON.	Obtain the abnormal unit number by reading AR bits 0000-0009 and remove the cause of the error. Then restart by turning on, then back off, the appropriate restart bit (AR bits 0100-0109). If the Unit does not recover normal operation after restarting, replace it with a new one.

AR Area Error and Restart Bits for Special I/O Units

Error Flags

The following error flags will turn ON when the same unit number is assigned to more than one Special I/O Unit, or when the refreshing operation between the PC and the Special I/O Unit is not executed properly.

Bit	Unit Number
AR 000	0
AR 001	1
AR 002	2
AR 003	3
AR 004	4
AR 005	5
AR 006	6
AR 007	7
AR 008	8
AR 009	9

Restart Bits

These restart bits are turned OFF, ON, and back OFF again to restart Special I/O Units. Turning OFF power to the Unit is necessary when using its restart bit.

Bit	Unit Number
AR 0100	0
AR 0101	1
AR 0102	2
AR 0103	3
AR 0104	4
AR 0105	5
AR 0106	6
AR 0107	7
AR 0108	8
AR 0109	9

8-6 Detection of Abnormal Pulse Outputs

The Position Control Unit outputs pulse trains in accordance with the programmed data. When tracing an abnormality, the following should be taken into consideration.

Number of Pulses

The Unit only outputs the number of pulses required to reach the target position. Count the number of pulses being output with an up/down counter and check to see if the proper number of pulses is being output.

Frequency of Pulse Train Output

The frequency of pulse train output can be observed on a synchroscope at the constant speed interval of the trapezoidal acceleration/deceleration. To measure the frequency during acceleration and deceleration, an F/V converter and X-Y recorder can be used. For regular maintenance, observation of the frequency at staple speed intervals with a synchroscope is sufficient.

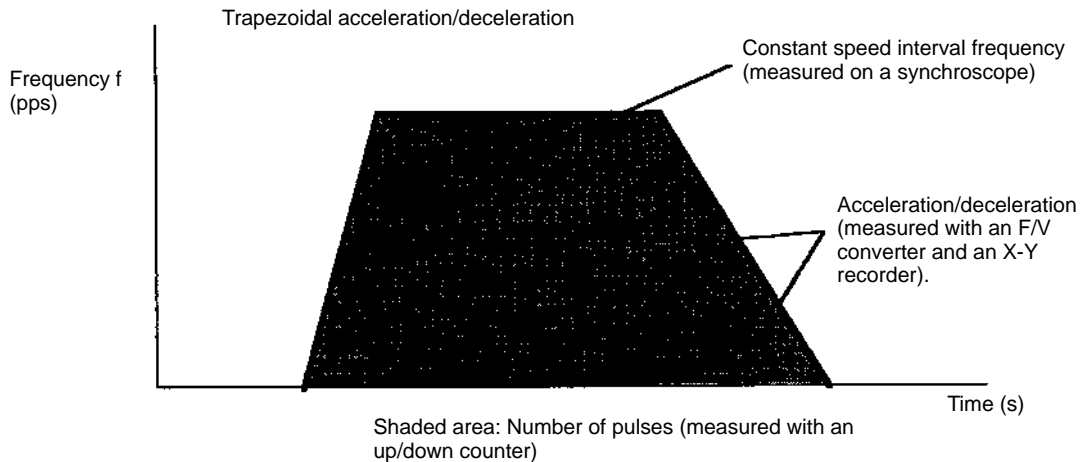

Position Control Unit

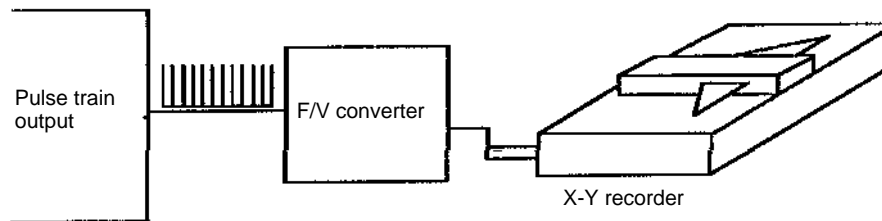

Connections to an Up/Down Counter

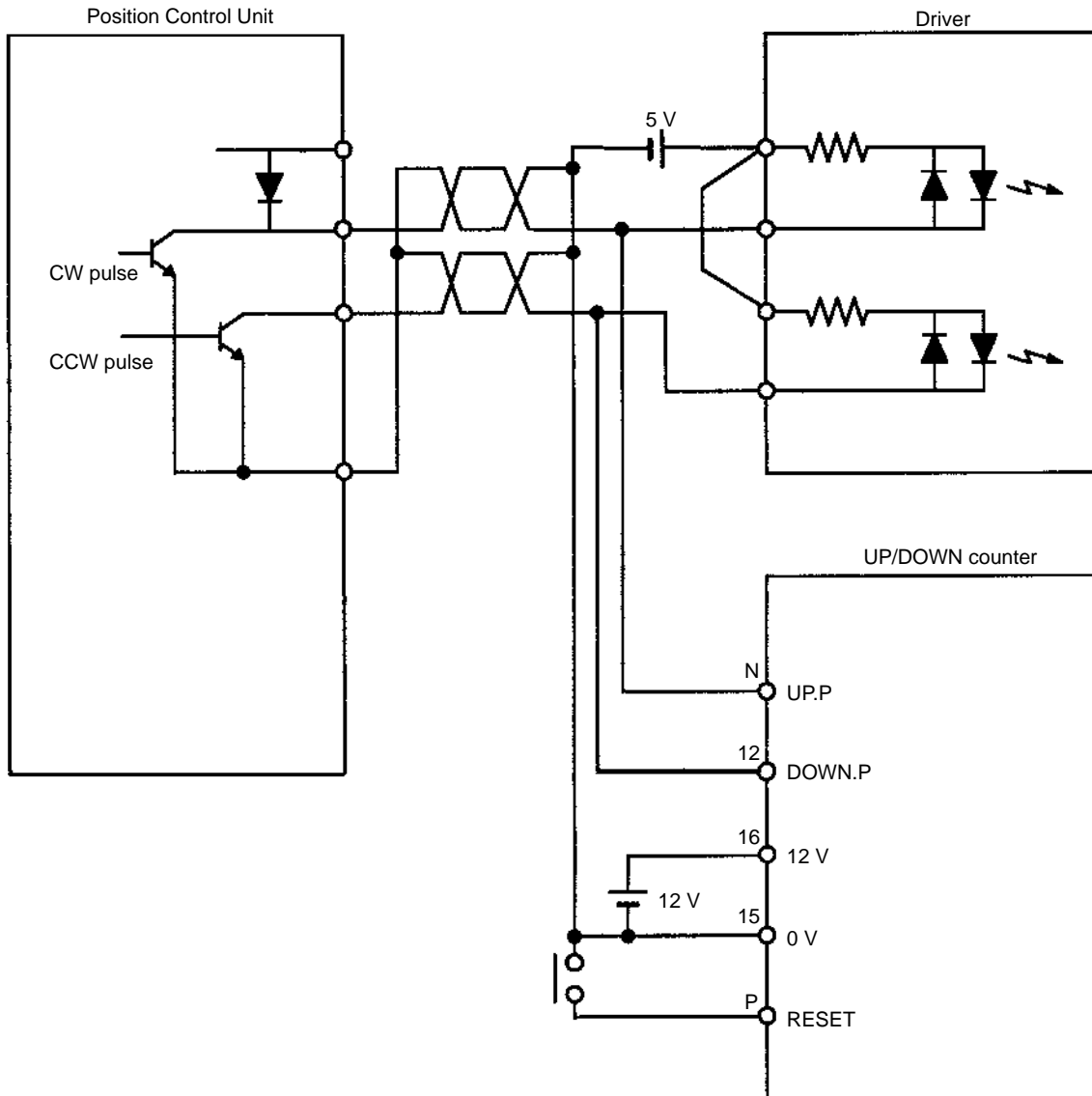

8-7 Alarm Code List

Note When interpolating, the Y axis error code is also output to the X-axis alarm/error code word (n + 11).

Area	Item	Alarm Code	Problem
Initial speed	BCD error	1000	There is a BCD error in the speed indicated by the initial speed number.
Initial positioning action no.	Limit error	1100	Initial positioning action number is not between 00 and 19.
Jog operations	HIGH-SPEED JOG speed error	1200	HIGH-SPEED JOG speed number is 0, or there is a BCD error in the speed designated by the number.
	LOW-SPEED JOG speed error	1201	LOW-SPEED JOG speed number is 0, or there is a BCD error in the speed designated by the number.
Acceleration/deceleration	Acceleration error	1300	Acceleration is 0, or contains a BCD error.
	Deceleration error	1301	Deceleration is 0 or contains a BCD error.
ORIGIN RETURN	Speed error	1400	ORIGIN RETURN speed designated by the number is 0, or there is a BCD error in the speed designated by the number.
Speeds	Speed contradiction	1500	Table for trapezoidal acceleration/deceleration cannot be created due to error in speed, acceleration, or deceleration.
	BCD error	1501	There is a BCD error in speed #1.
		1502-1515	There is a BCD error in the speed data m+82 to m+96 which is indicated by the speed number designated by the last two digits.
ORIGIN SEARCH	Origin compensation BCD error	1600	Origin compensation contains a BCD error or exceeds the internal limit.
	High speed error	1601	ORIGIN SEARCH high speed number is 0, or there is a BCD error in the speed designated by the number.
	Proximity speed error	1602	ORIGIN SEARCH proximity speed number is 0, or there is a BCD error in the speed designated by the number.
	Speed contradiction	1603	High speed is slower than proximity speed.
Backlash compensation	BCD error	1700	There is a BCD error in the backlash compensation.

Continued . . .

Area	Item	Alarm Code	Problem
Internal limits	CW limit	1800	There is a BCD error in internal CW limit setting or the setting is not between 0 and 8,388,606.
	CCW limit	1801	There is a BCD error in internal CCW limit setting or the setting is not between 0 and 8,388,607.
Zones	Zone 0 CW error	1900	There is a BCD error in setting for CW limit of zone 0 or setting is not between -8,388,607 and 8,388,606.
	Zone 0 CCW error	1901	There is a BCD error in setting for CCW limit of zone 0 or setting is not between -8,388,607 and 8,388,606.
	Zone 0 contradiction	1902	CW and CCW limit setting for zone 0 are reversed (i.e., CW limit is counterclockwise of CCW limit).
	Zone 1 CW error	1910	Problems are identical to those for zone 0.
	Zone 1 CCW error	1911	
	Zone 1 contradiction	1912	
	Zone 2 CW error	1920	Problems are identical to those for zone 0.
	Zone 2 CCW error	1921	
Zone 2 contradiction	1922		
Positioning actions	Target position BCD error	2000	There is a BCD error in the target position for positioning action #0.
		2001-2052	There is a BCD error in the target position for the positioning action designated by the last two digits of the alarm code. There is a BCD error in the target position m+25 to m+81 which is indicated by the position No. designated by the last two digits.
	Speed BCD error	2100	There is a BCD error in the speed designated by the speed number for positioning action #0.
		2101-2152	There is a BCD error in the speed data m+82 to m+96 which is indicated by the target speed number designated by the last two digits.
	Position contradiction	2200	The completion codes for all positioning actions are 2 (continuous); the Unit cannot begin operation.
	Completion code error	2300	Completion code for positioning action #0 is not between 0 and 5.
2301-2352		There is a BCD error in the position data designated by the last two digits of the alarm code.	

8-8 Error Code List

Note When interpolating, the Y axis error code is also output to the X-axis alarm/error code word (n + 11).

Error	Error code	Problem	Correction
START	5000	Pulses cannot be output for START command because of data that generated an alarm. This data includes the initial speed, initial positioning action number, acceleration, deceleration, backlash compensation, internal CW limit, internal CCW limit, speed and target position.	Read out alarm code and correct data accordingly. The error code will be erased for the next START if data has been properly corrected.
Interpolation data	5010	Single-axis and interpolation data are mixed at initialization. This is a prohibited completion code.	Check the program. This error code is cancelled at the next data transfer.
Direction reversed	5020	Pulse output is not possible because the direction was reversed following a continuous positioning action.	Check positioning actions and correct data.
CW limit	5030	Pulse output is not possible because the internal CW limit would be passed.	
CCW limit	5031	Pulse output is not possible because the internal CCW limit would be passed.	
Present position undefined	5040	Execution of START, TEACH, or ORIGIN RETURN is not possible because the present position has not been established.	Execute ORIGIN SEARCH, RESET ORIGIN, or preset the present position with TRANSFER DATA.
Stopped at CW limit	5060	An attempt was made to feed clockwise using HIGH-SPEED JOG, LOW-SPEED JOG, or INCH following RELEASE PROHIBIT after feeding had been stopped at CCW limit.	
Stopped at CCW limit	5061	An attempt was made to feed counterclockwise using HIGH-SPEED JOG, LOW-SPEED JOG, or INCH following RELEASE PROHIBIT after feeding had been stopped at CCW limit.	
Manual CW limit	5070	The internal CW limit was reached and feeding stopped during execution of HIGH-SPEED JOG, LOW-SPEED JOG, or INCH.	Feed counterclockwise.
Manual CCW limit	5071	The internal CCW limit was reached and feeding stopped during execution of HIGH-SPEED JOG, LOW-SPEED JOG, or INCH.	Feed clockwise.
ORIGIN SEARCH disabled	5100	ORIGIN SEARCH cannot be executed because of data for the origin compensation, search speeds, or backlash compensation that generated an alarm code.	Read out alarm code and correct data accordingly.

Continued . . .

Error	Error code	Problem	Correction
ORIGIN RETURN disabled	5200	ORIGIN RETURN cannot be executed because of data for ORIGIN RETURN speed or backlash compensation that generated alarm.	Read out alarm code and correct and correct data accordingly.
HIGH-SPEED JOG disabled	5300	HIGH-SPEED JOG cannot be executed because of data for HIGH-SPEED JOG speed, initial speed, acceleration, deceleration, or backlash compensation that generated an alarm.	
LOW-SPEED JOG disabled	5400	LOW-SPEED JOG cannot be executed because of data for LOW-SPEED JOG speed, initial speed, or backlash compensation that generated an alarm.	
INCH disabled	5500	INCH cannot be executed because of data for backlash compensation that generated an alarm.	
Emergency stop executed	6000	Feeding has been stopped by emergency stop signal input.	Check wiring. Turn off emergency stop signal and execute RELEASE PROHIBIT and ORIGIN SEARCH.
CW limit	6100	Feeding has been stopped by CW limit signal input.	Check wiring. Execute RELEASE PROHIBIT and then feed counterclockwise using HIGH-SPEED JOG, LOW-SPEED JOG, or INCH (or execute ORIGIN SEARCH after RELEASE PROHIBIT).
CCW limit	6101	Feeding has been stopped by CCW limit signal input.	Check wiring. Execute RELEASE PROHIBIT and then feed clockwise using HIGH-SPEED JOG, LOW-SPEED JOG, or INCH (or execute ORIGIN SEARCH after RELEASE PROHIBIT).
No origin proximity signal	6200	No proximity signal is detected between the CCW and CW limits even though pin #3 on DIP switch designates a proximity signal.	Check DIP switch setting, wiring of proximity signal, and signal type (N.C. or N.O.).
No-origin flag	6201	The origin signal is not detected between CCW and CW limits.	Check wiring of origin signal and signal type (N.C. or N.O.)
Origin signal position	6202	Feeding was stopped by origin signal input during ORIGIN SEARCH before the proximity speed was reached, i.e., proximity signal and origin signal are too close relative to time required for deceleration from high speed to proximity speed.	Check position of origin signal and proximity signal relative to required deceleration.
Counterclockwise CW limit	6400	CW limit signal was input while feeding counterclockwise.	Check wiring of limit signals.
Clockwise CCW limit	6401	CCW limit signal was input while feeding clockwise.	Check wiring of limit signals.
PC mode change	6600	PC mode was changed between MONITOR and PROGRAM during pulse output.	Execute ORIGIN SEARCH to obtain present position.

Continued . . .

Error	Error code	Problem	Correction
CHANGE SPEED	6700	Feeding has been stopped during pulse output following CHANGE SPEED due to data for the speed of the next positioning action for which an alarm was generated.	Check speed data. If problem is corrected, this error code will be erased by the next START.
Multiple command	8000	More than one command bit has been set simultaneously.	Check program. This error code will be erased when every command bit in channel n goes to 0.
Initial positioning action no.	8100	Initial positioning action number contained in IR area is not between 00 and 19.	Check program. If problem is corrected, this error code will be erased by the next START.
TEACH positioning action no.	8200	TEACH positioning action number is not between 00 and 19.	Check program. If problem is corrected, this error code will be erased by the next TEACH.
ROM in PC	8210	TEACH cannot be executed because PC user program memory is ROM.	Check program. This error code will be erased by the next TRANSFER DATA.
Transferred positioning action no.	8300	Beginning transfer number for TRANSFER DATA is not between 00 and 25.	
PC beginning word number	8301	Beginning PC word number for TRANSFER DATA is out of range or becomes out of range when the designated number of transfers is added. (See 7-4 TRANSFER DATA for range details.)	
PC area number	8302	PC area number for TRANSFER DATA is not between 0 and 4.	Check program. This error code will be erased by the next TRANSFER DATA.
Number of transfers	8303	The number of transfers for TRANSFER DATA contains a BCD error or is out of range.	Check program. This error code will be erased by the next TRANSFER DATA.
Present position preset	8304	The position preset with TRANSFER DATA contains a BCD error or is out of range.	Check program and data in PC.
TRANSFER DATA timing	8405	TRANSFER BUFFER executed during Transfer buffer.	Check the program. This error code will be erased by the next DATA TRANSFER.
Transfer buffer timing	8306	Transfer buffer executed during TRANSFER BUFFER.	Check the program. This error code will be erased by the next DATA TRANSFER.
Hardware	9000	LSI initial processing at start-up is not completed normally.	Hardware is possibly faulty.
	9100	Target position for a positioning action has been exceeded.	Hardware is possibly faulty or error is possibly caused by noise.
	9200	Speed for a positioning action has been exceeded.	

SECTION 9

Programming Examples

9-1	Example 1	190
9-2	Example 2	196
9-3	Example 3	199
9-4	Example 4	201
9-5	Example 5	203
9-6	Example 6	208
9-7	Example 7	210
9-8	Example 8	218
9-9	Example 9	219
9-10	Example 10	221
9-11	Example 11	229

Section Overview

This section presents programming examples which illustrate how to use the many different commands and settings in operating the Position control Unit.

9-1 Example 1

Operation with Minimum Data: Displaying JOG Positions

Wiring

The illustration below shows the simplest possible wiring for operation of the Position Control Unit.

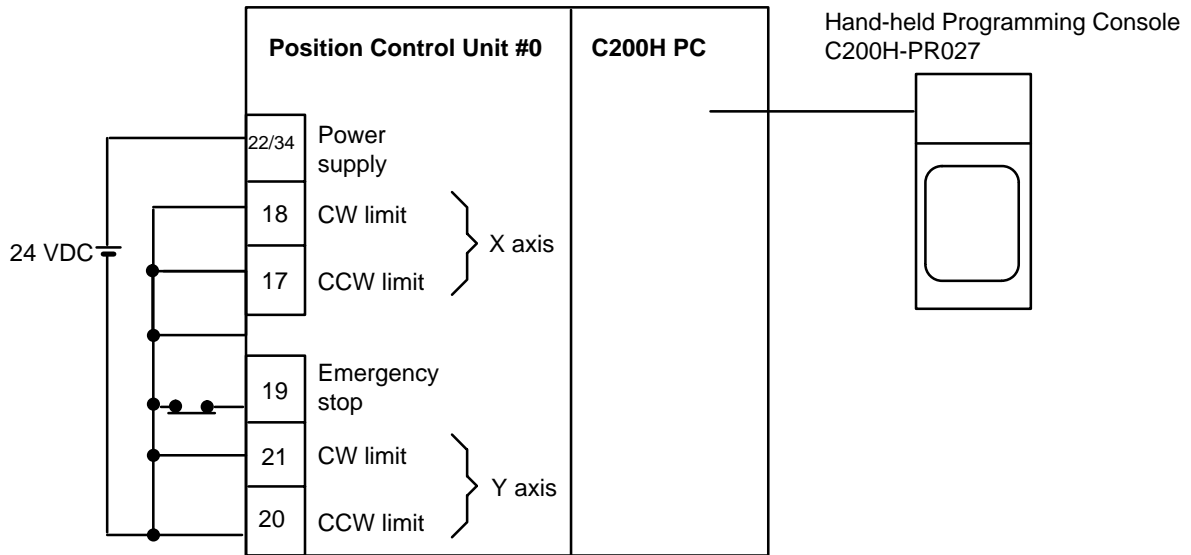

DM Area Settings

The data settings shown below are the minimum required to prevent the alarm/error LED from flashing.

X axis:

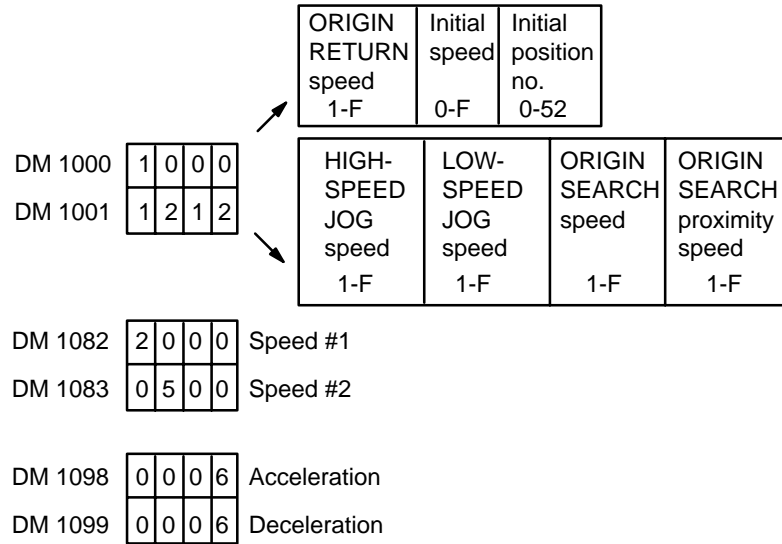

Y axis:

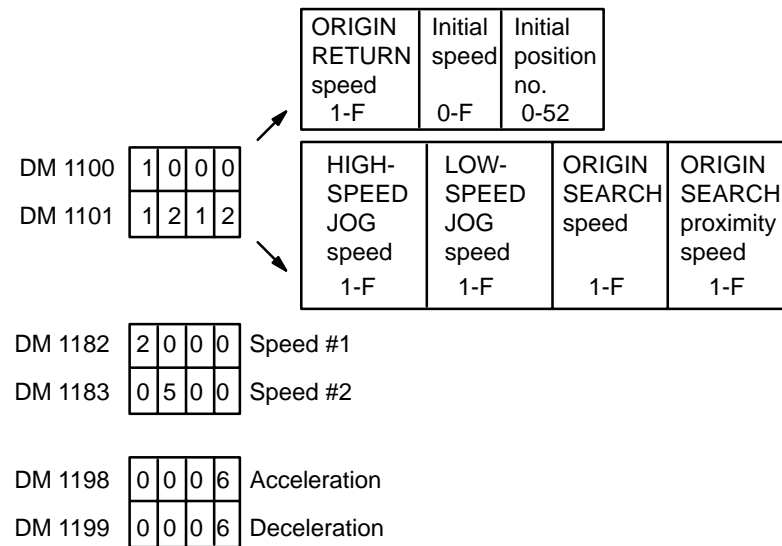

Procedure for the X Axis

- 1, 2, 3... 1. Set the PC to PROGRAM mode, and then begin operation from the Programming Console.
2. Write data into the DM area and restart.

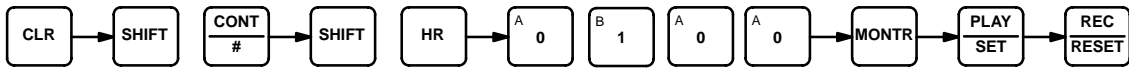

A0100
^OFF

3. Monitor the present position words.

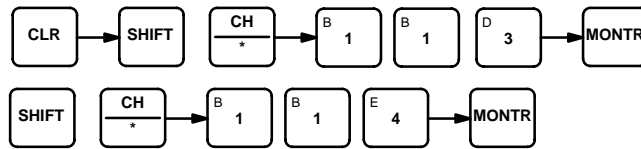

C114 C113
0999 9911

4. Monitor the RESET ORIGIN command bit.

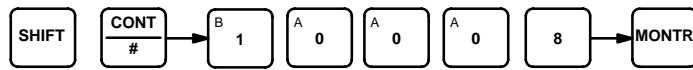

10008 C114 C113
^OFF 0999 9911

5. Reset the present position.

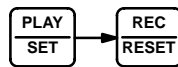

10008 C114 C113
^OFF 0000 0000

6. Set LOW-SPEED JOG command bit.



Programming Console Display

```
10013 C114 C113
^ON 0000 2340
```

The values of the present position increase or decrease.

Indicators on Position Control Unit

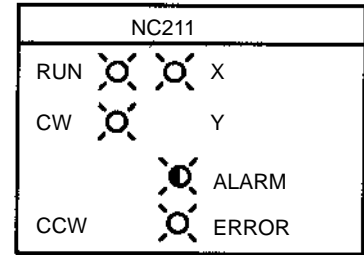

CW and busy LEDs light.
(with 10012, direction, OFF)

7. Stop LOW-SPEED JOG.



```
10013 C114 C113
^OFF 0001 0615
```

Procedure for the Y Axis

- 1, 2, 3... 1. Set the PC to PROGRAM mode, and then begin operation from the Programming Console.
2. Write data into the DM area and restart.

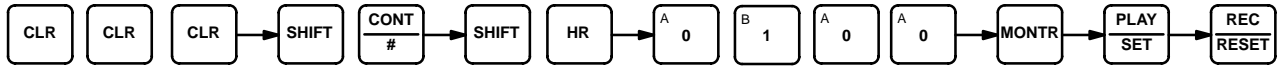

A0100
^OFF

3. Monitor the present position words.

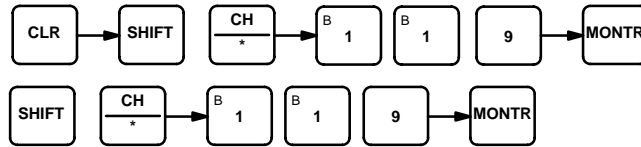

C119 C118
0999 9911

4. Monitor the RESET ORIGIN command bit.



10508 C119 C118
^OFF 0999 9911

5. Reset the present position.

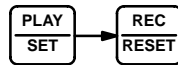

10508 C119 C118
^OFF 0000 0000

6. Set LOW-SPEED JOG command bit.



Programming Console Display

```
10513 C119 C118  
^ON 0000 2340
```

The values of the present position increase or decrease.

Indicators on Position Control Unit

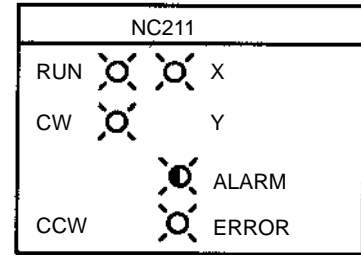

CW and Y LEDs light.

7. Stop LOW-SPEED JOG.



```
10053 C119 C118  
^OFF 0001 0615
```



9-2 Example 2

Positioning at an Interval: Using RESET ORIGIN

In this example, the Position Control Unit is assumed to be assigned unit number 0. (Single-axis START)

Operation

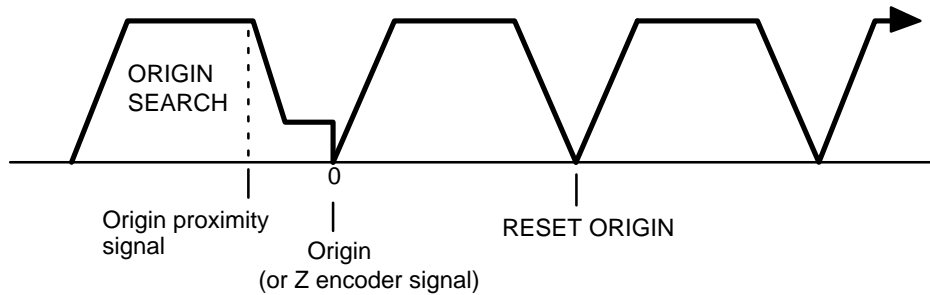
Feeding is executed to positions lying at equal distances in the same direction from a specific point; it is executed repeatedly using the same positioning action followed by RESET ORIGIN.



DM Area Settings for the X Axis

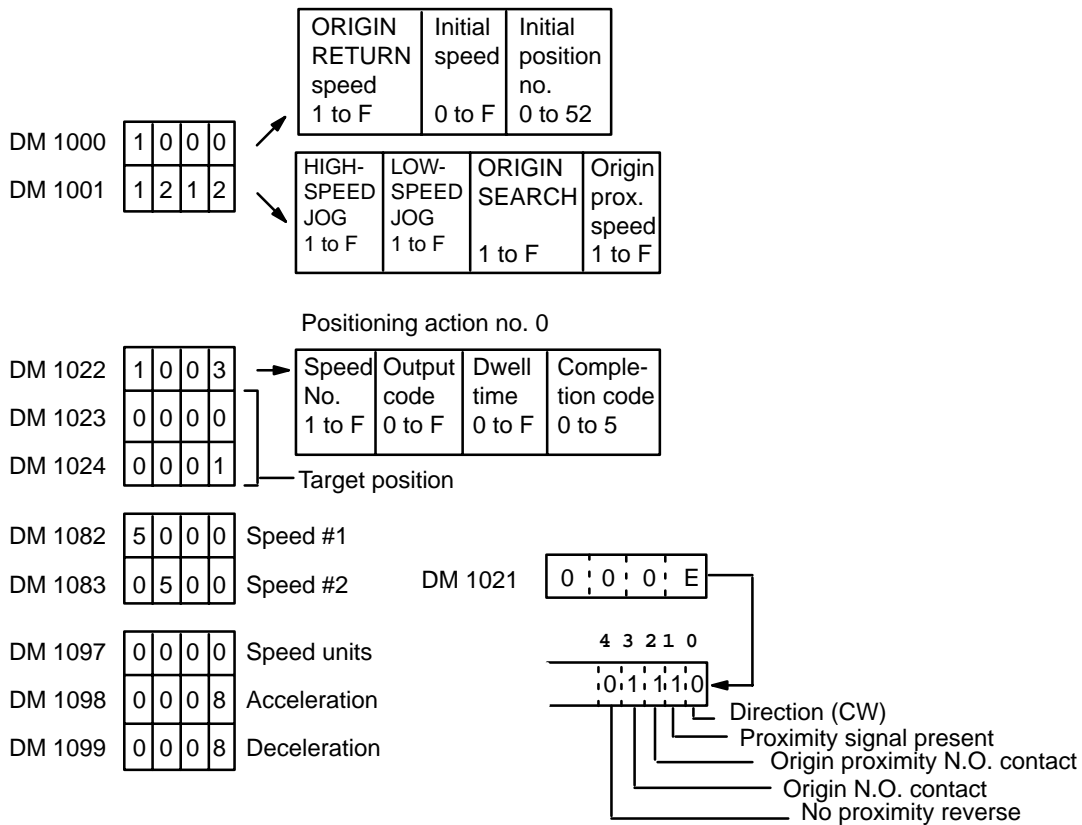

DM Area Settings for the Y Axis

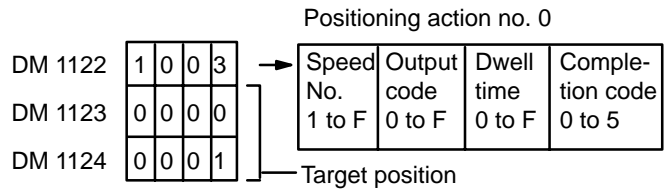
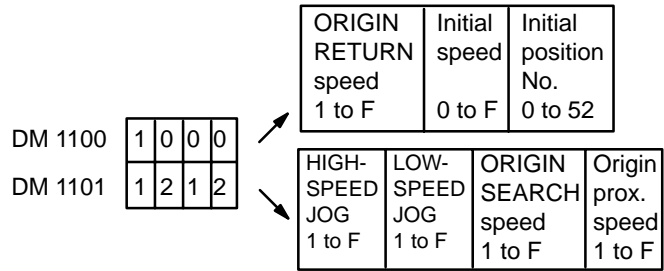

DM 1182 5 0 0 0 Speed No. 1
 DM 1183 0 5 0 0 Speed No. 2

DM 1197 0 0 0 0 Speed units
 DM 1198 0 0 0 8 Acceleration
 DM 1199 0 0 0 8 Deceleration

Program

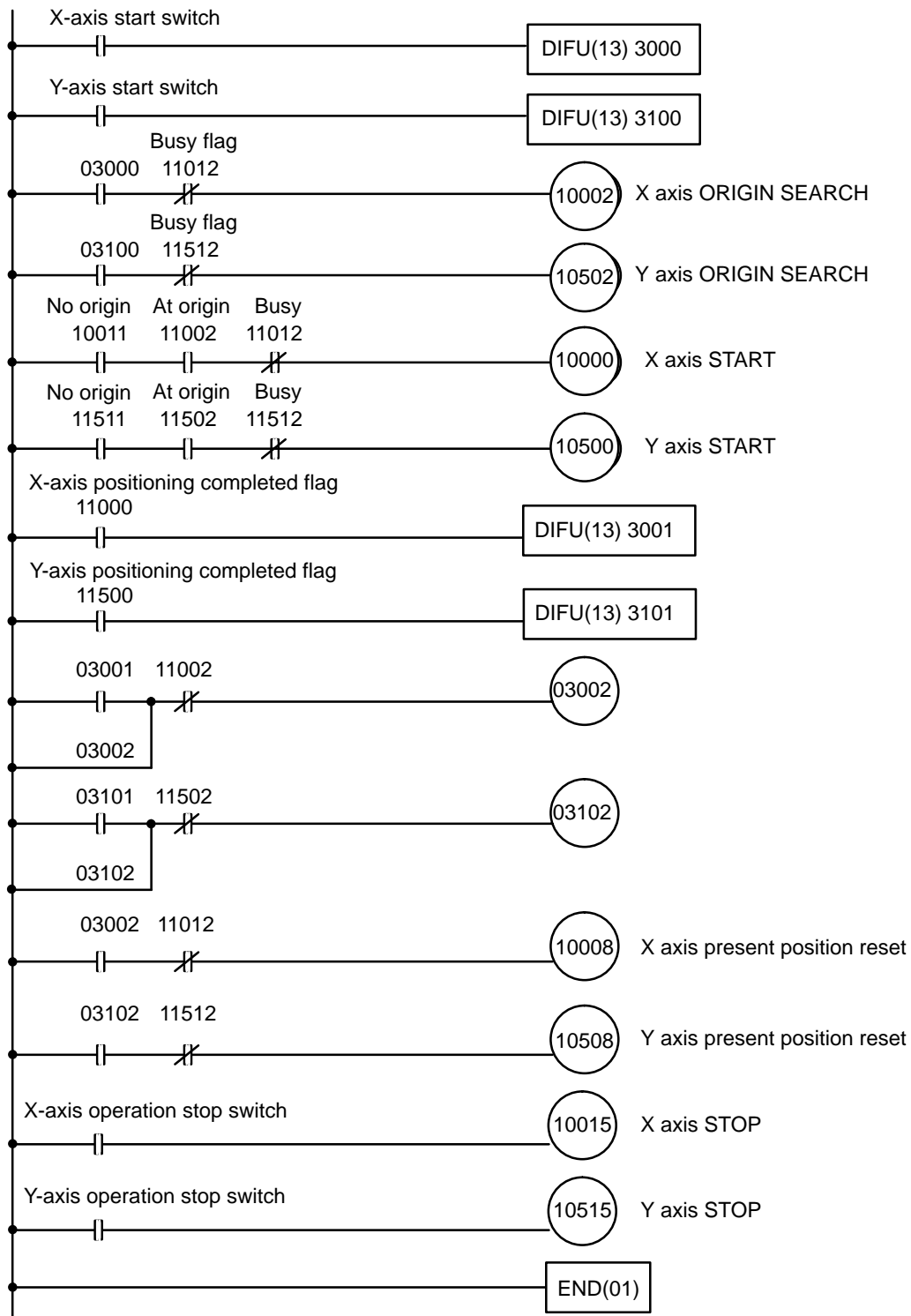

9-3 Example 3

Using the Origin and Origin Proximity Signals

Configuration (mode 0)

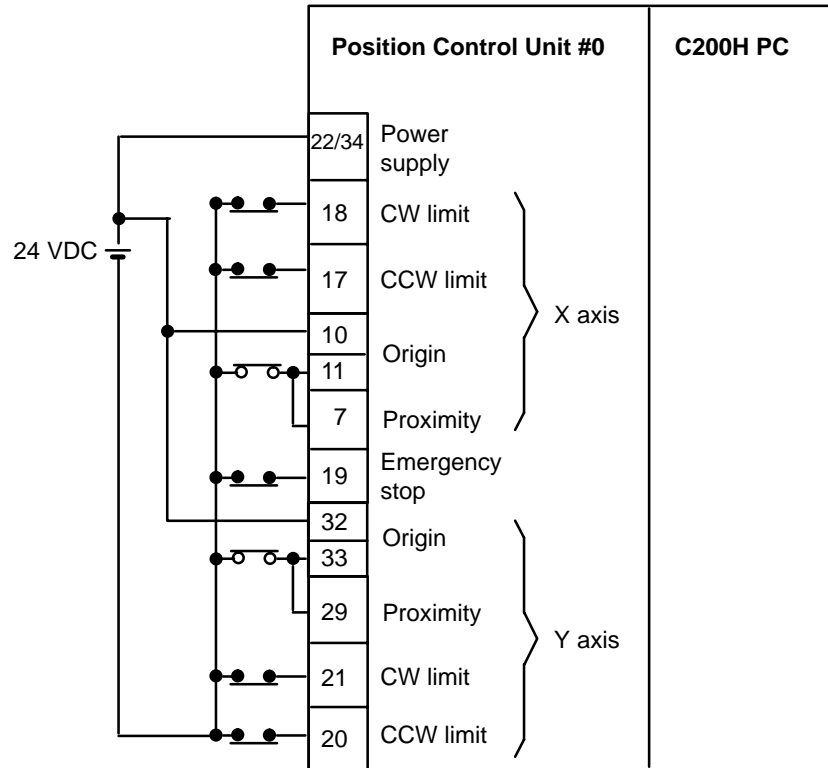

DM Area Settings

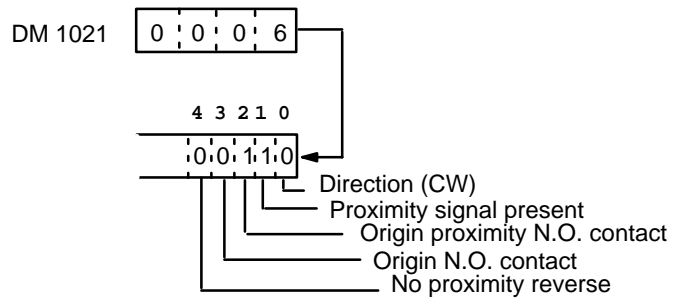

Operation

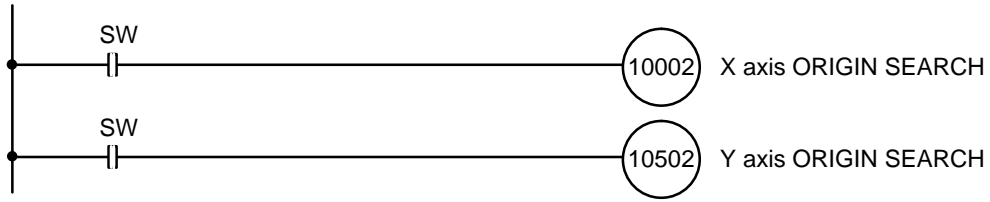

The possible search patterns for ORIGIN SEARCH using both an origin signal and an origin proximity signal are shown below.

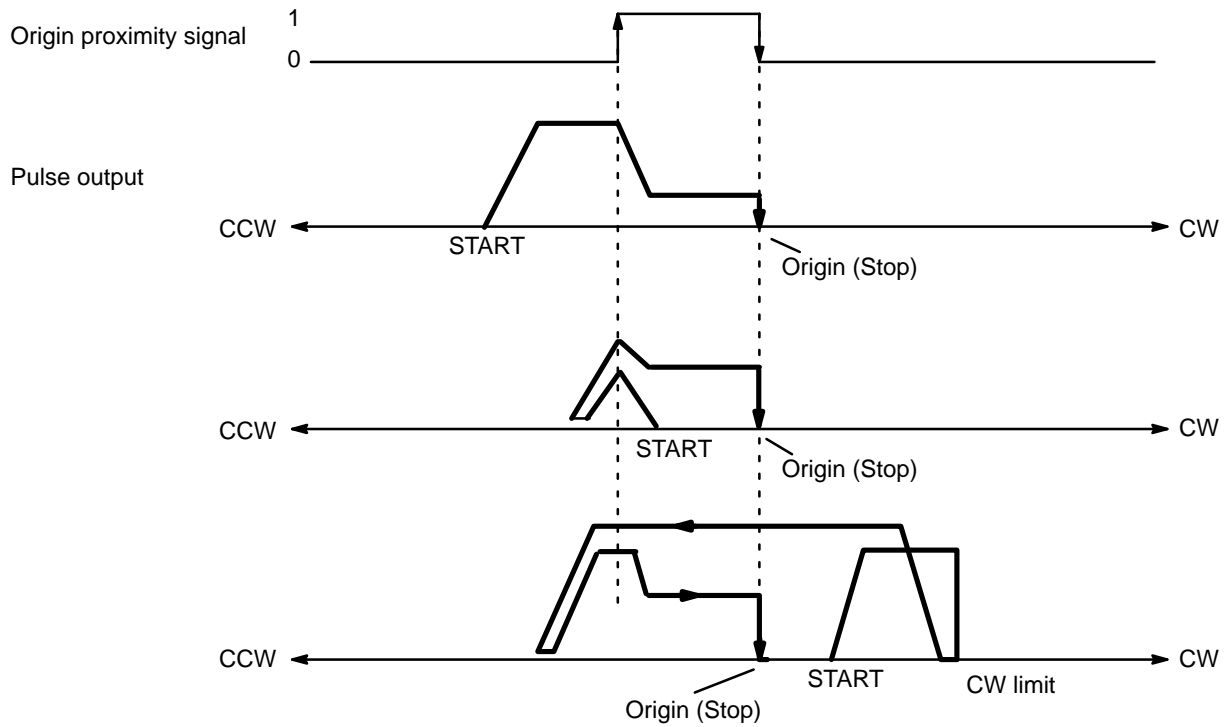

9-4 Example 4

Positioning After ORIGIN SEARCH

Operation

Operation alternates between an initial positioning action and ORIGIN RETURN, using a point on the X axis as a reference (point A in the diagram below). After STOP switch input, operation returns to the origin and stops.

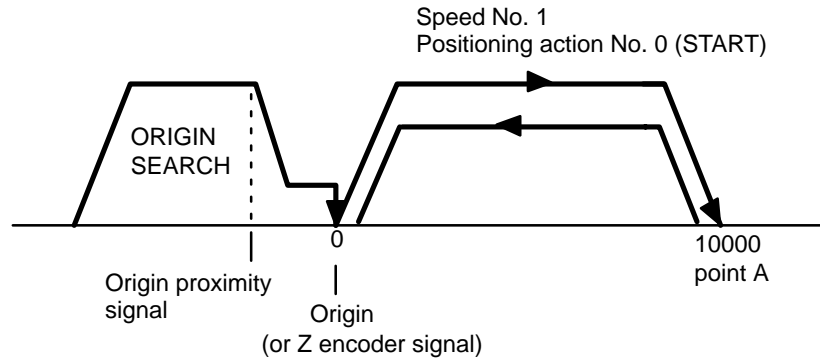

DM Area Settings

ORIGIN RETURN speed	Initial speed	Initial position no.
1 to F	0 to F	0 to 52

HIGH-SPEED JOG	LOW-SPEED JOG	ORIGIN SEARCH	Origin prox. speed
1 to F	1 to F	1 to F	1 to F

DM 1000

1	1	0	0
---	---	---	---

 →

DM 1001

1	2	1	2
---	---	---	---

 →

Positioning action no. 0

Speed No.	Output code	Dwell time	Completion code
1 to F	0 to F	0 to F	0 to 5

DM 1022

1	0	0	3
---	---	---	---

 →

DM 1023

0	0	0	0
---	---	---	---

 →

DM 1024

0	0	0	1
---	---	---	---

 → Target position

DM 1082

5	0	0	0
---	---	---	---

 Speed No. 1

DM 1083

0	5	0	0
---	---	---	---

 Speed No. 2

DM 1097

0	0	0	0
---	---	---	---

 Speed units

DM 1098

0	0	0	8
---	---	---	---

 Acceleration

DM 1099

0	0	0	8
---	---	---	---

 Deceleration

DM 1021

0	0	0	E
---	---	---	---

4 3 2 1 0

0 1 1 1 0

- Direction (CW)
- Proximity signal present
- Origin proximity N.O. contact
- Origin N.O. contact
- No proximity reverse

Program

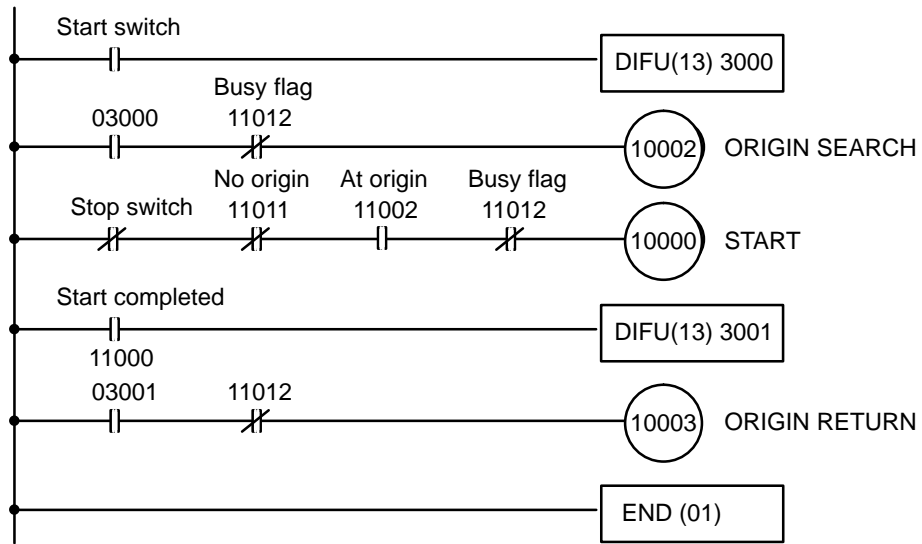

9-5 Example 5

Point to Point Operation on Both the X and Y Axes

This example shows how to use ORIGIN SEARCH, present position reset, or START after present position reset to operate simultaneously on both the X and Y axes. (Unit No. 0 is used for the purpose of this example.)

1. Independent Operation

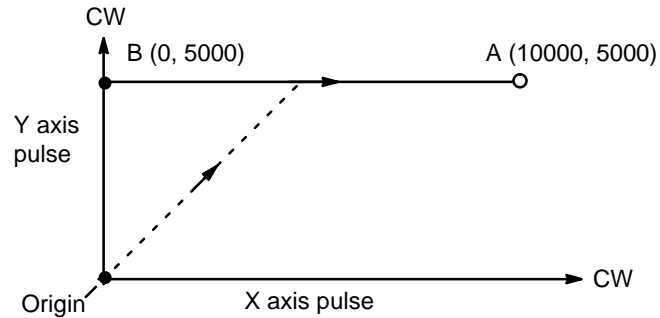

In the diagram above, single axis positioning is executed from the origin (0, 0) to point B (0, 5000) on the Y axis, followed by point A (10000, 5000) on the X axis. X axis START use the Y axis positioning completed flag (bit 00 of word n+15). When simultaneous operation on both axes is executed with the same DM area settings, X axis START receives priority. It takes 10-50 ms to process X axis START, and Y axis START must wait for that processing to finish.

DM Area Settings

	X axis		Y axis																	
DM 1000	<table border="1"><tr><td>1</td><td>0</td><td>0</td><td>0</td></tr></table>	1	0	0	0	DM 1100	<table border="1"><tr><td>1</td><td>0</td><td>0</td><td>0</td></tr></table>	1	0	0	0	<table border="1"> <tr> <td>ORIGIN RETURN speed</td> <td>Initial speed</td> <td>Initial position No.</td> </tr> <tr> <td>1 to F</td> <td>0 to F</td> <td>0 to 52</td> </tr> </table>	ORIGIN RETURN speed	Initial speed	Initial position No.	1 to F	0 to F	0 to 52		
1	0	0	0																	
1	0	0	0																	
ORIGIN RETURN speed	Initial speed	Initial position No.																		
1 to F	0 to F	0 to 52																		
DM 1001	<table border="1"><tr><td>1</td><td>2</td><td>1</td><td>2</td></tr></table>	1	2	1	2	DM 1101	<table border="1"><tr><td>1</td><td>2</td><td>1</td><td>2</td></tr></table>	1	2	1	2	<table border="1"> <tr> <td>HIGH-SPEED JOG</td> <td>LOW-SPEED JOG</td> <td>ORIGIN SEARCH speed</td> <td>Origin prox. speed</td> </tr> <tr> <td>1 to F</td> <td>1 to F</td> <td>1 to F</td> <td>1 to F</td> </tr> </table>	HIGH-SPEED JOG	LOW-SPEED JOG	ORIGIN SEARCH speed	Origin prox. speed	1 to F	1 to F	1 to F	1 to F
1	2	1	2																	
1	2	1	2																	
HIGH-SPEED JOG	LOW-SPEED JOG	ORIGIN SEARCH speed	Origin prox. speed																	
1 to F	1 to F	1 to F	1 to F																	
				Positioning action no. 0																
DM 1022	<table border="1"><tr><td>1</td><td>0</td><td>0</td><td>3</td></tr></table>	1	0	0	3	DM 1122	<table border="1"><tr><td>1</td><td>0</td><td>0</td><td>3</td></tr></table>	1	0	0	3	<table border="1"> <tr> <td>Speed No.</td> <td>Output code</td> <td>Dwell time</td> <td>Completion code</td> </tr> <tr> <td>1 to F</td> <td>0 to F</td> <td>0 to F</td> <td>0 to 5</td> </tr> </table>	Speed No.	Output code	Dwell time	Completion code	1 to F	0 to F	0 to F	0 to 5
1	0	0	3																	
1	0	0	3																	
Speed No.	Output code	Dwell time	Completion code																	
1 to F	0 to F	0 to F	0 to 5																	
DM 1023	<table border="1"><tr><td>0</td><td>0</td><td>0</td><td>0</td></tr></table>	0	0	0	0	DM 1123	<table border="1"><tr><td>5</td><td>0</td><td>0</td><td>0</td></tr></table>	5	0	0	0									
0	0	0	0																	
5	0	0	0																	
DM 1024	<table border="1"><tr><td>0</td><td>0</td><td>0</td><td>1</td></tr></table>	0	0	0	1	DM 1124	<table border="1"><tr><td>0</td><td>0</td><td>0</td><td>0</td></tr></table>	0	0	0	0									
0	0	0	1																	
0	0	0	0																	
				Target position																
DM 1082	<table border="1"><tr><td>1</td><td>0</td><td>0</td><td>0</td></tr></table>	1	0	0	0	DM 1182	<table border="1"><tr><td>1</td><td>0</td><td>0</td><td>0</td></tr></table>	1	0	0	0	Speed No. 1								
1	0	0	0																	
1	0	0	0																	
DM 1083	<table border="1"><tr><td>0</td><td>1</td><td>0</td><td>0</td></tr></table>	0	1	0	0	DM 1183	<table border="1"><tr><td>0</td><td>1</td><td>0</td><td>0</td></tr></table>	0	1	0	0	Speed No. 2								
0	1	0	0																	
0	1	0	0																	
DM 1098	<table border="1"><tr><td>0</td><td>0</td><td>0</td><td>5</td></tr></table>	0	0	0	5	DM 1198	<table border="1"><tr><td>0</td><td>0</td><td>0</td><td>5</td></tr></table>	0	0	0	5	Acceleration								
0	0	0	5																	
0	0	0	5																	
DM 1099	<table border="1"><tr><td>0</td><td>0</td><td>0</td><td>5</td></tr></table>	0	0	0	5	DM 1199	<table border="1"><tr><td>0</td><td>0</td><td>0</td><td>5</td></tr></table>	0	0	0	5	Deceleration								
0	0	0	5																	
0	0	0	5																	

Program

The following diagram shows a program for executing START independently on each axis.

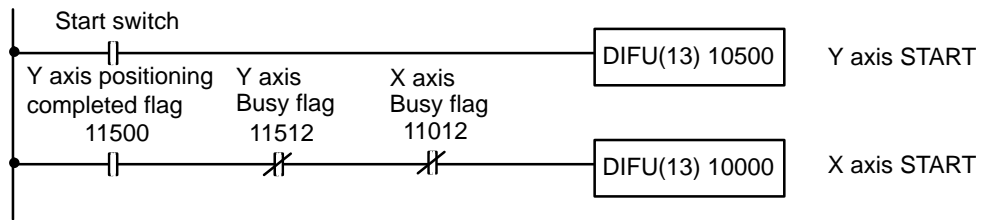

The next diagram shows the program for simultaneous START on both axes.

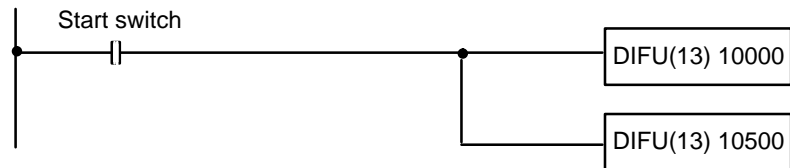

Note When operations are started on both axes simultaneously, the X axis receives priority. It takes 10-50 ms to process X axis START, and Y axis START must wait for that processing to finish.

2. Interpolation Operation with Independent Axis START

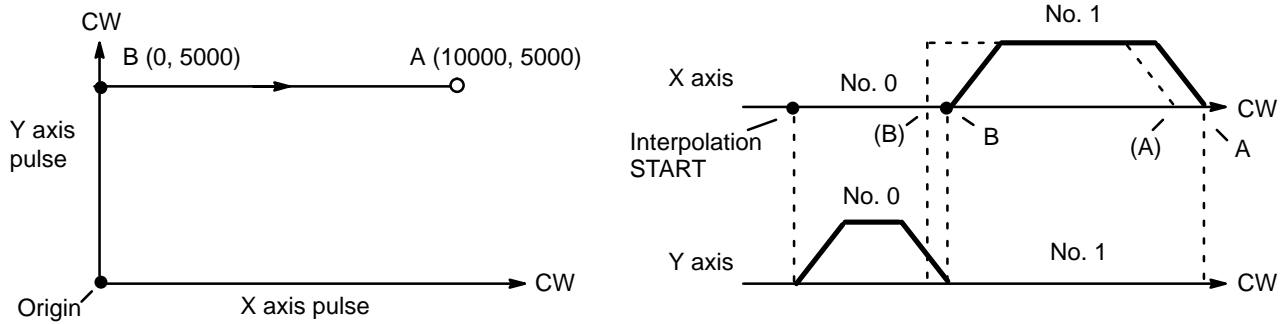

The same operation as in Example 1 is possible with interpolation; there are more DM area settings to make, but the program itself is simpler. The completion code in DM word 1022 changes from #1 (Single) to #2 (Continuous), allowing continuous operation (shown by the dotted lines in the diagram). For interpolation START, use X axis START.

DM Area Settings

X axis		Y axis		ORIGIN RETURN speed 1 to F	Initial speed 0 to F	Initial position no. 0 to 52
DM 1000	1 0 0 0	DM 1100	1 0 * * *	HIGH-SPEED JOG 1 to F	LOW-SPEED JOG 1 to F	ORIGIN SEARCH speed 1 to F
DM 1001	1 2 1 2	DM 1101	1 2 1 2	Origin prox. speed 1 to F	Positioning action no. 0	
DM 1022	1 0 0 1	DM 1122	1 0 * * 1	Speed No. 1 to F	Output code 0 to F	Dwell time 0 to F
DM 1023	0 0 0 0	DM 1123	5 0 0 0	Completion code 0 to 5		
DM 1024	4 0 0 0	DM 1124	0 0 0 0	Target position		
DM 1025	1 1 0 3	DM 1125	1 * 1 * 3	Direction		
DM 1026	0 0 0 0	DM 1126	0 0 0 0	Positioning action no. 1		
DM 1027	4 0 0 1	DM 1127	0 0 0 0			
DM 1082	1 0 0 0	DM 1182	1 0 0 0	* Speed No. 1		
DM 1083	0 1 0 0	DM 1183	0 1 0 0	* Speed No. 2		
DM 1098	0 0 0 5	DM 1198	0 0 0 5	* Acceleration		
DM 1099	0 0 0 5	DM 1199	0 0 0 5	* Deceleration		

Program

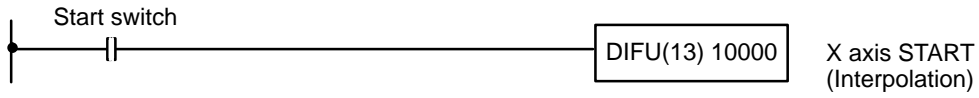

When the direction of the X axis positioning action is set from 4 to 7, it becomes interpolation data. The speed, acceleration, deceleration, output code, and dwell time settings for interpolation become X axis values. Y axis settings (marked with an asterisk *) are ignored, but data must be input to prevent an alarm form being generated.

3. Linear Interpolation Operation

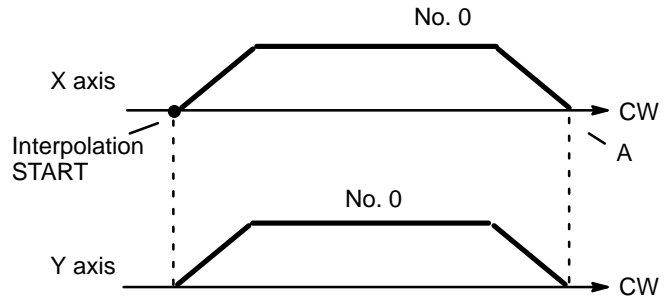
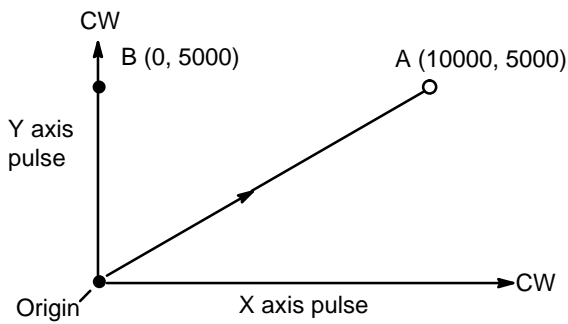

In this example, linear positioning is carried out from the origin (0, 0) to point A (10000, 5000). The speed of interpolation is the speed set for the X axis.

DM Area Settings

X axis				Y axis					
DM 1000	1	0	0	0	DM 1100	1	0	0	0
DM 1001	1	2	1	2	DM 1101	1	2	1	2
DM 1022	1	0	0	1	DM 1122	1	0	0	3
DM 1023	0	0	0	0	DM 1123	5	0	0	0
DM 1024	4	0	0	0	DM 1024	0	0	0	0
DM 1082	1	0	0	0	DM 1182	1	0	0	0
DM 1083	0	1	0	0	DM 1183	0	1	0	0
DM 1098	0	0	0	5	DM 1198	0	0	0	5
DM 1099	0	0	0	5	DM 1199	0	0	0	5

ORIGIN RETURN speed	Initial speed	Initial position no.
1 to F	0 to F	0 to 52

HIGH-SPEED JOG	LOW-SPEED JOG	ORIGIN SEARCH	Origin prox. speed
1 to F	1 to F	1 to F	1 to F

Positioning action no. 0

Speed No.	Output code	Dwell time	Completion code
1 to F	0 to F	0 to F	0 to 5

Target position

Direction			

Program

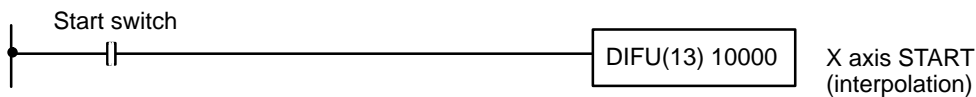

9-6 Example 6

Feeding Selectively with START

Configuration

The configuration here is the same as that for Example 1. There is no origin or origin proximity signal used. With the following data and program, the user can select feeding 4,000, 5,000, or 6,000 pulses at a time at 2,000 pps. The data settings shown below are the minimum required to prevent the alarm/error LED from flashing. The positioning actions are all CW (incremental) bank completion actions.

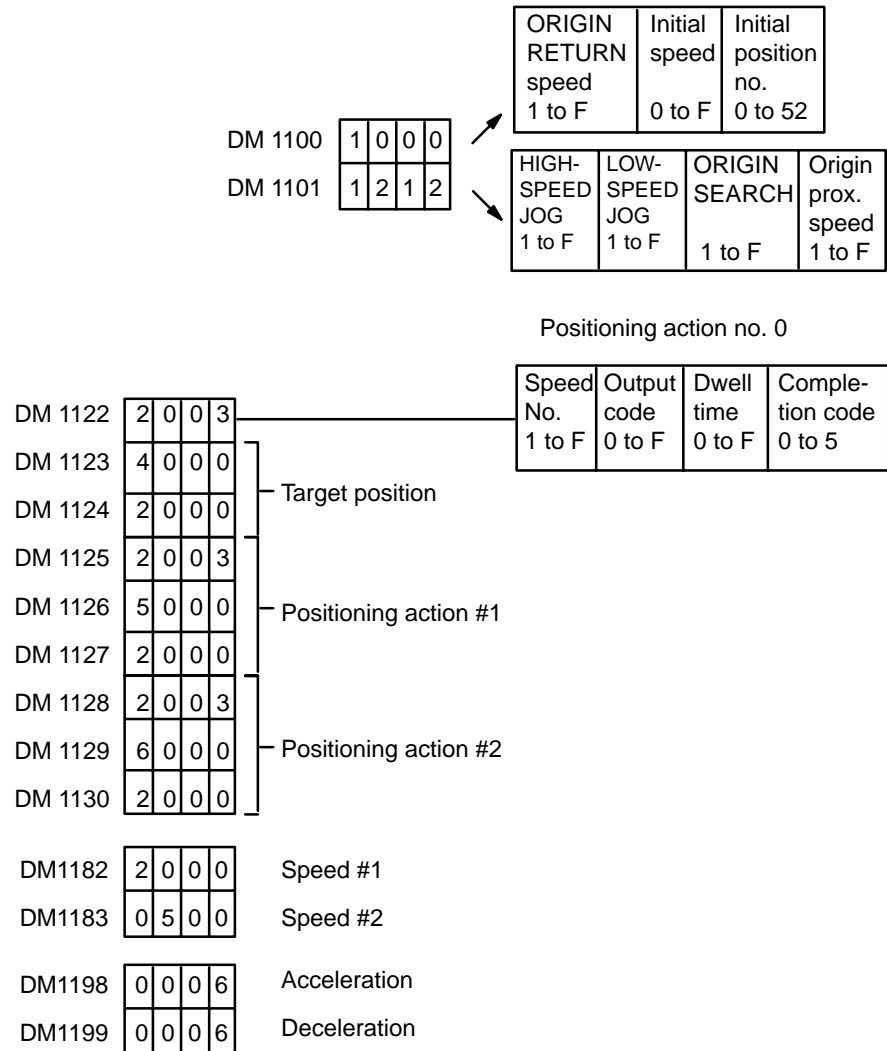

Program

With the following program, input A, B or C can be selected and START executed to feed the desired number of pulses.

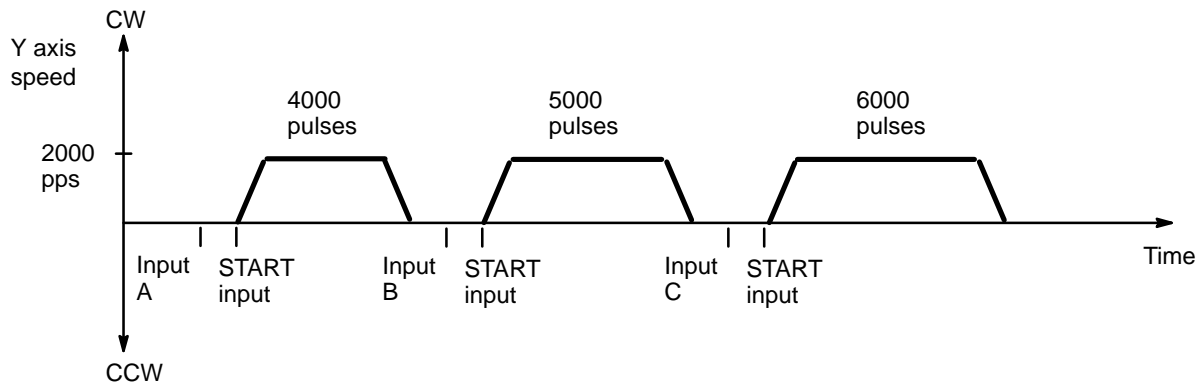
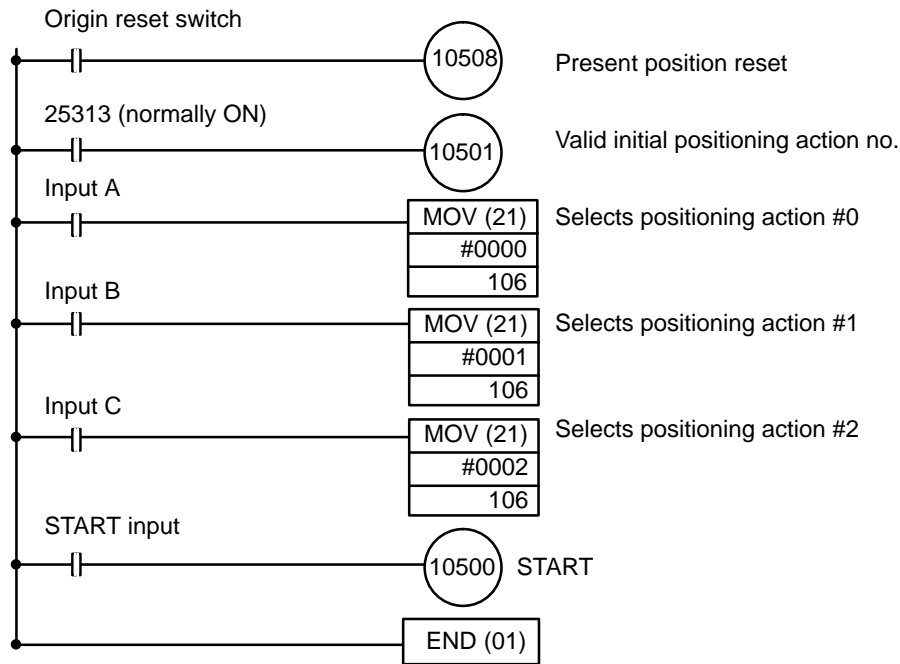

9-7 Example 7

Using START To Carry Out Positioning Actions

Wiring (Details Omitted)

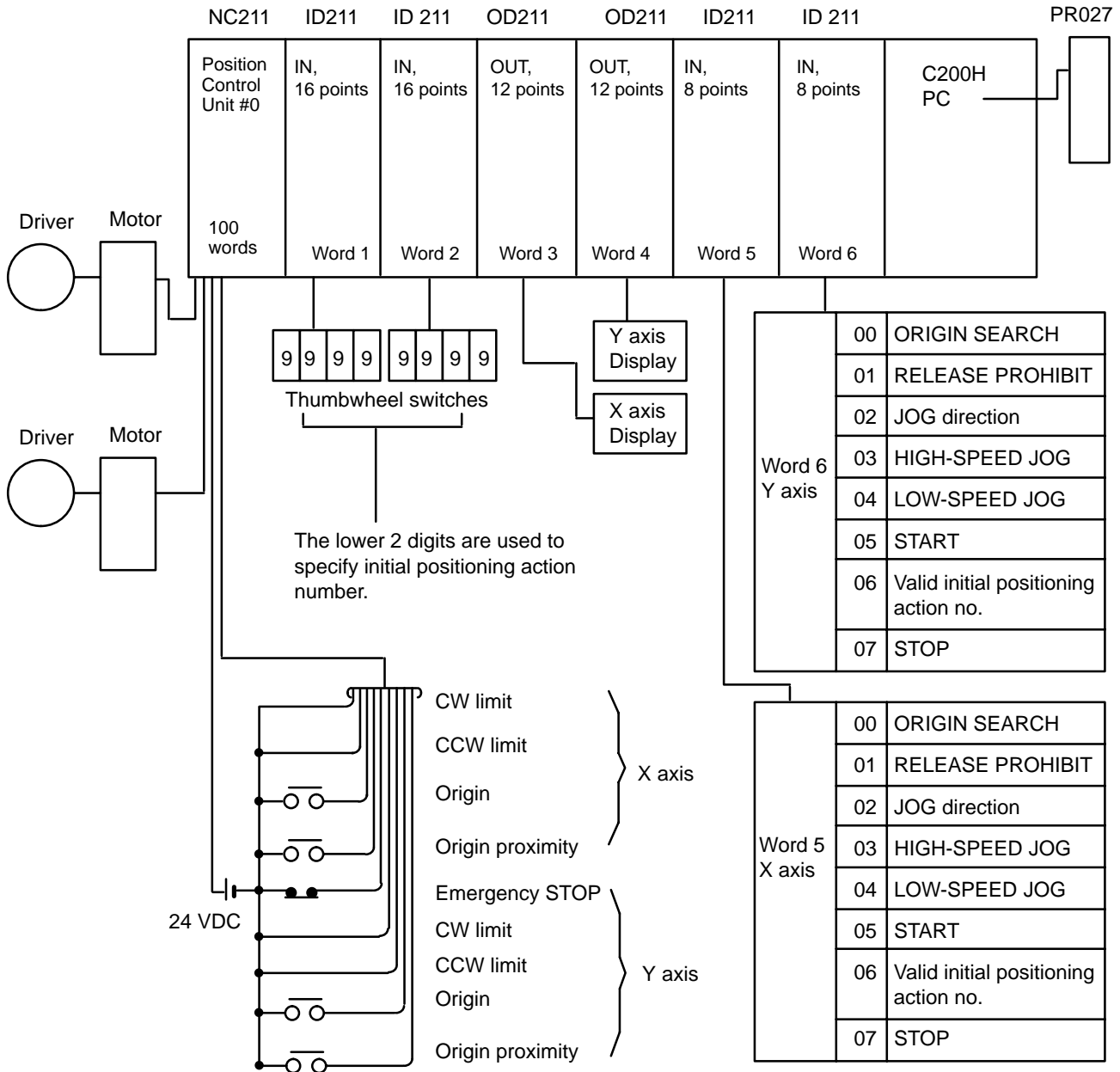

To execute positioning in autoincrement mode, turn ON 05 only. To forcibly execute the number specified by the thumbwheel switch, turn ON 06 and then 05.

To execute ORIGIN SEARCH, first turn ON switch 00, and then manually turn ON the origin proximity signal to stop feeding.

Program

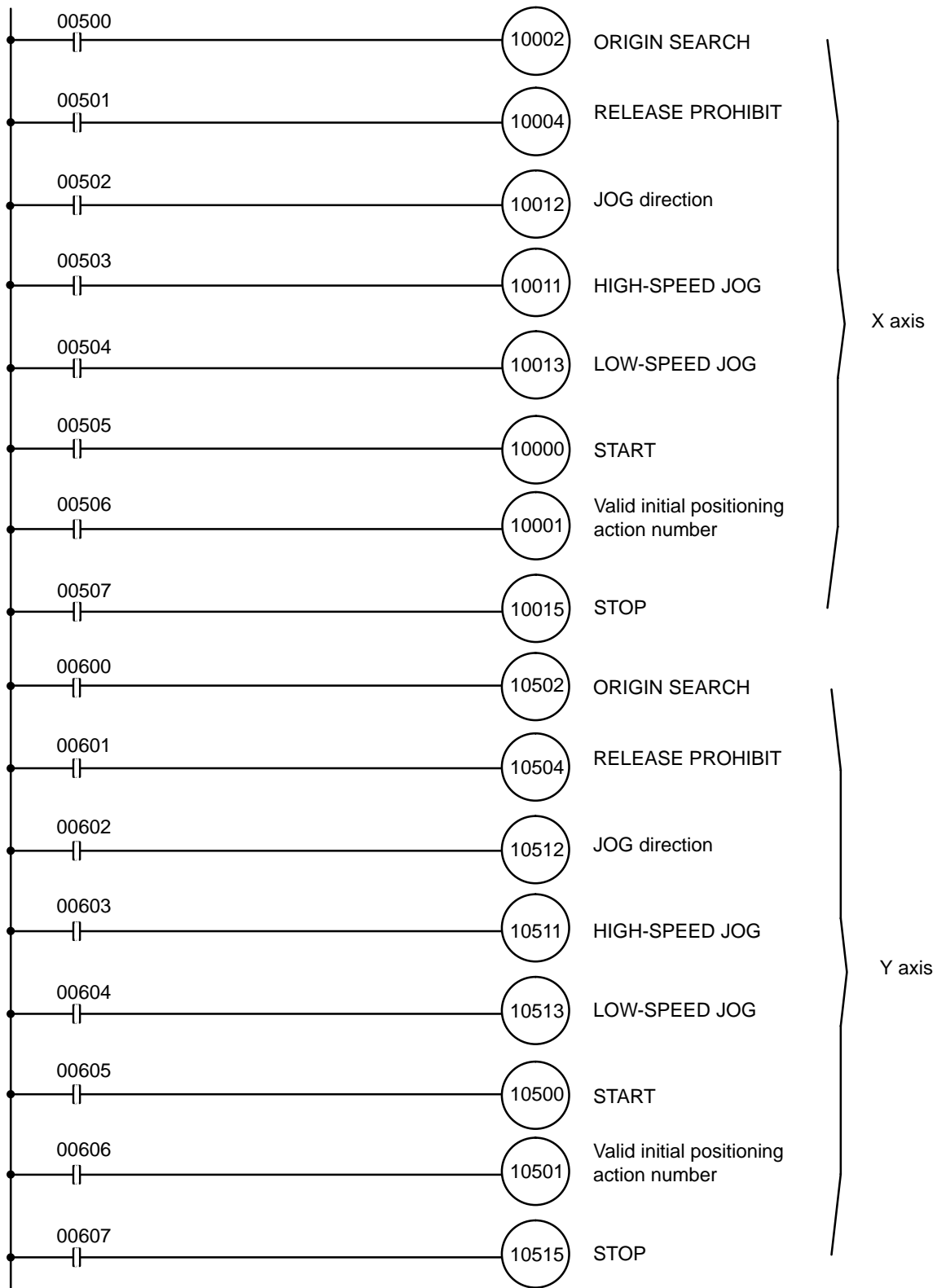

(continues on next page)

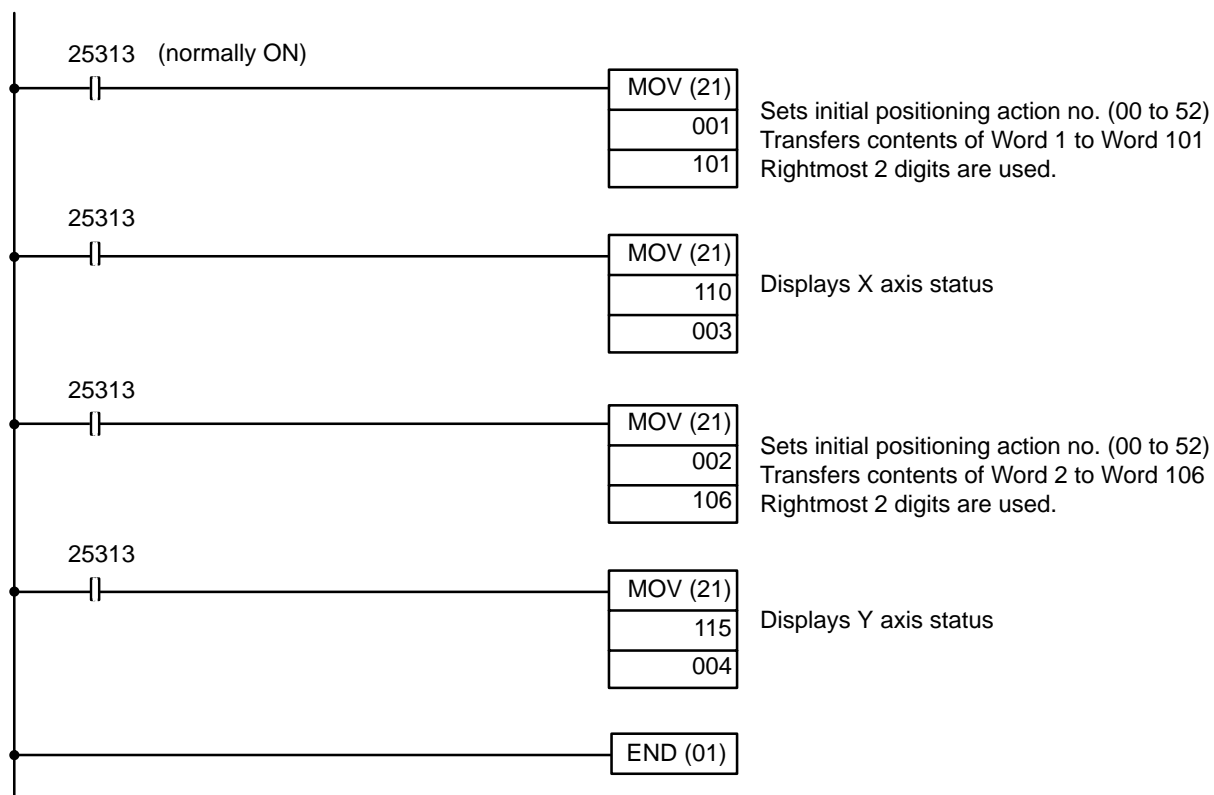

DM Area Coding Sheet

Unit Number: 0

Allocated DM words

DM 1000 through DM 1099

The first two digits of each word number have been eliminated from the tables on the following two pages. These digits are the same for all words and can be obtained by computing the first DM word allocated to the Unit, which in this example is DM 1000. This word, designated m , is equal to 1000 plus 100 times the unit number.

X axis					Function	W	15	00	Function	W	15	00	Function							
W	15	00																		
00	1	0	1	2	Initial position nos.; speed nos.	Transfer no. 7					Transfer no. 7									
01	2	3	4	5		34	9	1	A	1	Positioning action #4	4	67				Positioning action #15	15		
02	2	0	0	0	35	0	0	0	0	68										
03	0	0	0	0	36	4	0	0	5	69										
04	0	0	0	0	Backlash compensation	37	9	1	0	0	Positioning action #5	5	70			Positioning action #16	16			
05	0	0	0	0	CW limit	38	0	0	0	0			71							
06	0	8	0	0		39	4	0	0	6	72									
07	0	0	0	0	CCW limit	40	8	1	0	2	Positioning action #6	6	73			Positioning action #17	17			
08	0	8	0	0		41	0	0	0	0			74							
09	0	5	0	0	Zone 0 CW limit	42	4	0	0	1			75							
10	0	0	0	0		43	9	2	0	2	Positioning action #7	7	76			Positioning action #18	18			
11	0	5	0	0	Zone 0 CCW limit	44	0	0	0	0			77							
12	1	0	0	0		45	4	0	0	2			78							
13	0	0	0	0	Zone 1 CW limit	46	6	3	0	2	Positioning action #8	8	79			Positioning action #19	19			
14	0	0	0	1		47	0	0	0	0			80							
15	8	0	0	0	Zone 1 CCW limit	48	4	0	0	3			81							
16	0	0	0	0		49	7	4	0	2	Positioning action #9	9	82	5	0	0	0	Speed #1	53	
17	0	0	0	0	Zone 2 CW limit	50	0	0	0	0			83	5	0	0	0	Speed #2		
18	0	0	0	2		51	4	0	0	4			84	0	5	0	0	Speed #3		
19	5	0	0	0	Zone 2 CCW limit	52	3	5	0	2	Positioning action #10	10	85	4	0	0	0	Speed #4	54	
20	0	0	0	1		53	2	0	0	0			86	0	3	0	0	Speed #5		
21	0	0	0	E	Origin Origin proximity	54	4	0	0	4			87	1	0	0	0	Speed #6		
22	6	0	0	0	Positioning action #0	0	55	A	6	0	0	Positioning action #11	11	88	2	0	0	0	Speed #7	55
23	0	0	0	0			56	0	0	0	0			89	3	0	0	0	Speed #8	
24	4	0	0	1			57	4	0	0	6			90	4	0	0	0	Speed #9	
25	7	0	0	0	Positioning action #1	1	58	6	0	5	1	Positioning action #12	12	91	5	0	0	0	Speed #10	56
26	0	0	0	0			59	3	0	0	0			92	6	0	0	0	Speed #11	
27	4	0	0	2			60	4	0	0	0			93	7	0	0	0	Speed #12	
28	8	1	5	1	Positioning action #2	2	61	8	0	0	1	Positioning action #13	13	94	8	0	0	0	Speed #13	57
29	0	0	0	0			62	6	0	0	0			95	9	0	0	0	Speed #14	
30	4	0	0	3			63	5	0	0	0			96	1	0	0	0	Speed #15	
31	9	1	A	1	Positioning action #3	3	64	A	0	0	3	Positioning action #14	14	97	8	0	0	0	Speed units	58
32	0	0	0	0			65	0	0	0	0			98	0	1	0	0	Acceleration	
33	4	0	0	4			66	4	0	0	0			99	0	0	5	0	Deceleration	

Y axis					Function	W	15	00	Function	W	15	00	Function								
W	15	00	00	00																	
00	1	1	1	2	Initial position nos.; speed nos.	Transfer no. 7					Transfer no. 7										
01	2	3	4	5		34	9	1	A	1	Positioning action #4	4	67				Positioning action #15	15			
02	2	0	0	0	35	5	0	0	0	68											
03	0	0	0	0	36	0	0	0	2	69											
04	0	0	0	0	Backlash compensation	37	9	1	0	0	Positioning action #5	5	70			Positioning action #16	16				
05	0	0	0	0	CW limit	38	0	0	0	0			71								
06	0	8	0	0		39	0	0	0	3	72										
07	0	0	0	0	CCW limit	40	8	1	0	2	Positioning action #6	6	73			Positioning action #17	17				
08	0	8	0	0		41	5	0	0	0			74								
09	0	5	0	0	Zone 0 CW limit	42	0	0	0	0			75								
10	0	0	0	0		43	9	2	0	2	Positioning action #7	7	76			Positioning action #18	18				
11	0	5	0	0	Zone 0 CCW limit	44	0	0	0	0			77								
12	1	0	0	0	45	0	0	0	1	78											
13	0	0	0	0	Zone 1 CW limit	46	6	3	0	2	Positioning action #8	8	79			Positioning action #19	19				
14	0	0	0	1		47	5	0	0	0			80								
15	8	0	0	0	Zone 1 CCW limit	48	0	0	0	1			81								
16	0	0	0	0	Zone 2 CW limit	49	7	4	0	2	Positioning action #9	9	82	5	0	0	0	Speed #1	53		
17	0	0	0	0		50	0	0	0	0			83	5	0	0	0	0		Speed #2	
18	0	0	0	2		51	0	0	0	2			84	0	5	0	0	0		Speed #3	
19	5	0	0	0	Zone 2 CCW limit	52	3	5	0	2	Positioning action #10	10	85	4	0	0	0	Speed #4	54		
20	0	0	0	1		53	1	0	0	0			86	0	3	0	0	0		Speed #5	
21	0	0	0	6	Origin Origin proximity	54	0	0	0	2			87	1	0	0	0	0		Speed #6	
22	6	0	0	0	Positioning action #0	0	55	A	6	0	0	Positioning action #11	11	88	2	0	0	0	Speed #7	55	
23	5	0	0	0			56	0	0	0	0			89	3	0	0	0	0		Speed #8
24	0	0	0	0			57	0	0	0	3			90	4	0	0	0	0		Speed #9
25	7	0	0	0	Positioning action #1	1	58	6	0	5	1	Positioning action #12	12	91	5	0	0	0	Speed #10	56	
26	0	0	0	0			59	1	5	0	0			92	6	0	0	0	0		Speed #11
27	0	0	0	1			60	0	0	0	0			93	7	0	0	0	0		Speed #12
28	8	1	5	1	Positioning action #2	2	61	8	0	0	1	Positioning action #13	13	94	8	0	0	0	Speed #13	57	
29	5	0	0	0			62	3	0	0	0			95	9	0	0	0	0		Speed #14
30	0	0	0	1			63	1	0	0	0			96	1	0	0	0	0		Speed #15
31	9	1	A	1	Positioning action #3	3	64	A	0	0	3	Positioning action #14	14	97	8	0	0	0	Speed units	58	
32	0	0	0	0			65	0	0	0	0			98	0	1	0	0	0		Acceleration
33	0	0	0	2			66	0	0	0	0			99	0	0	5	0	0		Deceleration

Feeding Pattern

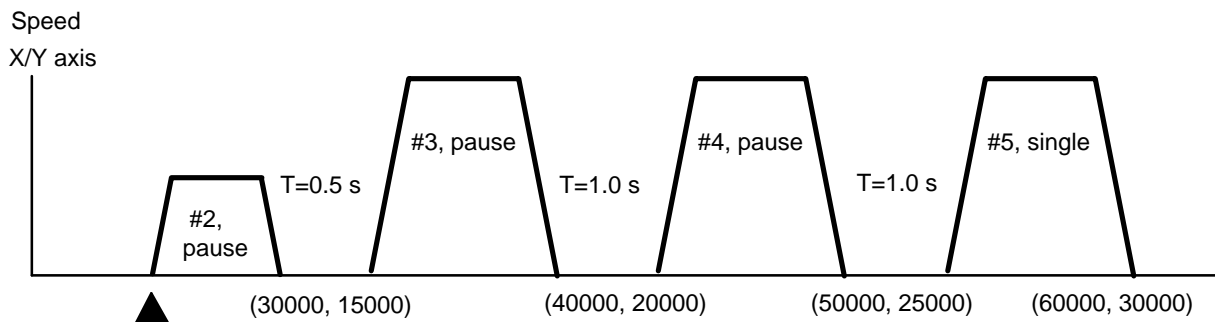
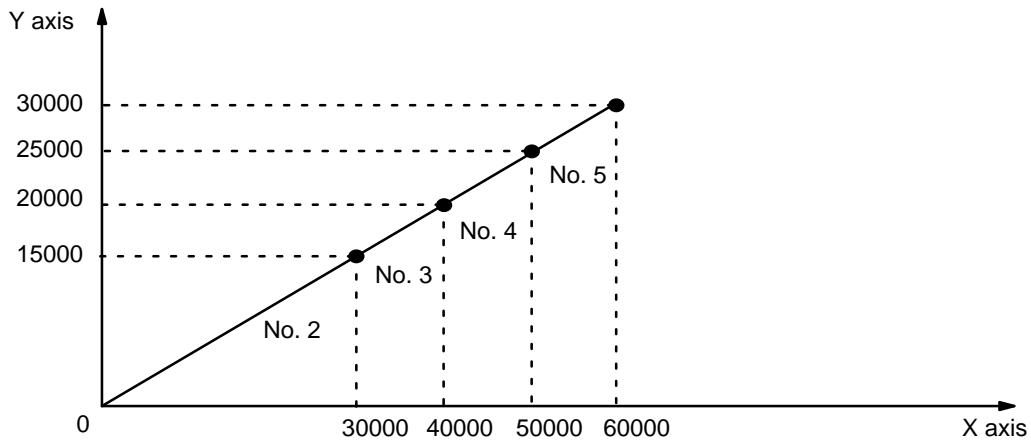
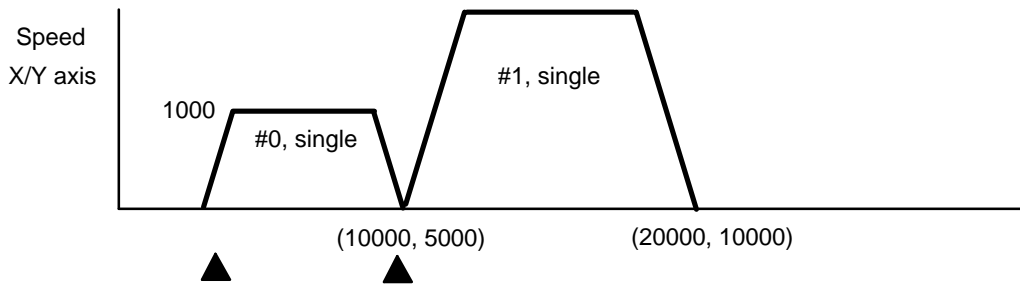
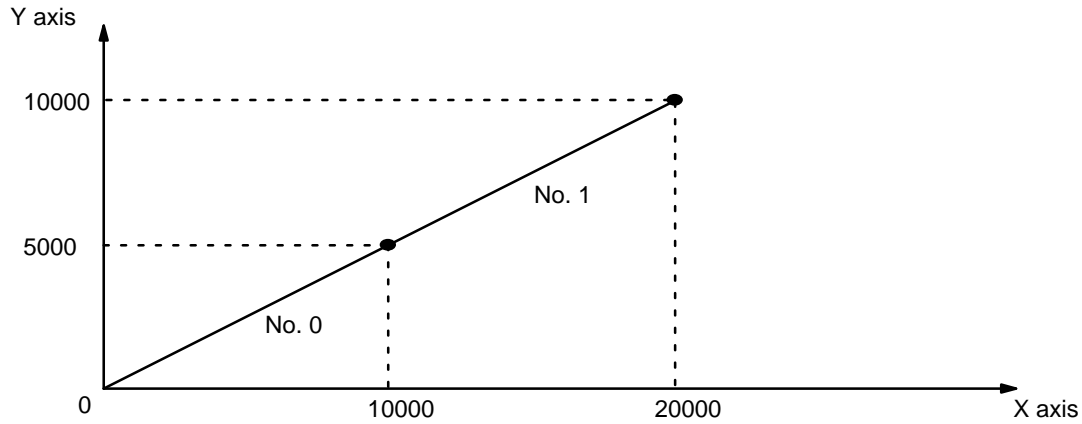

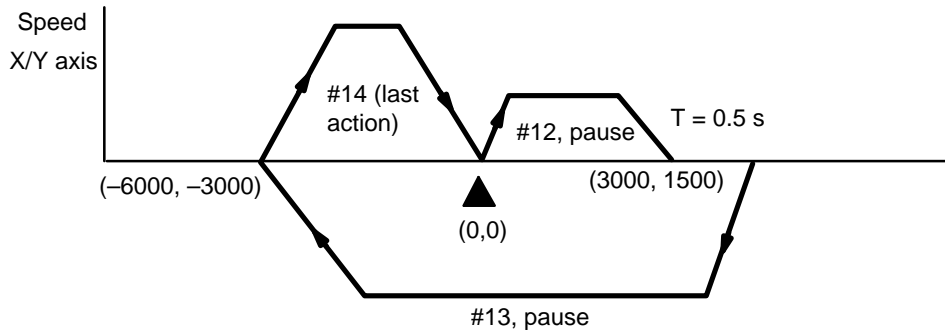
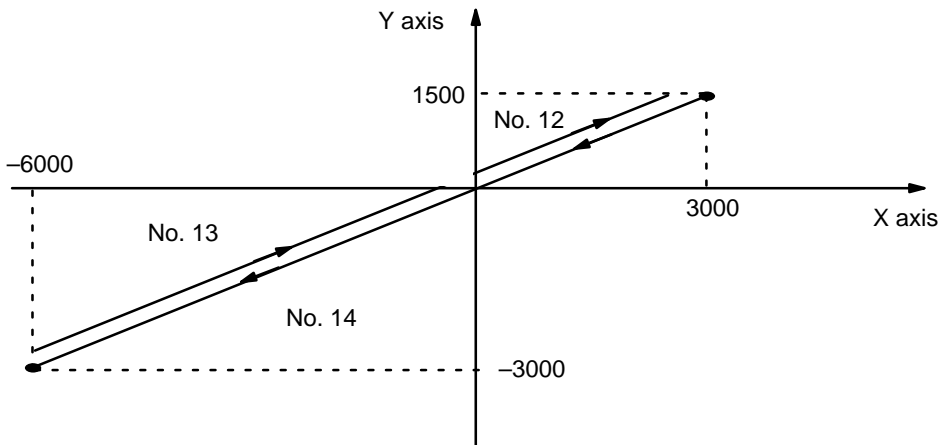
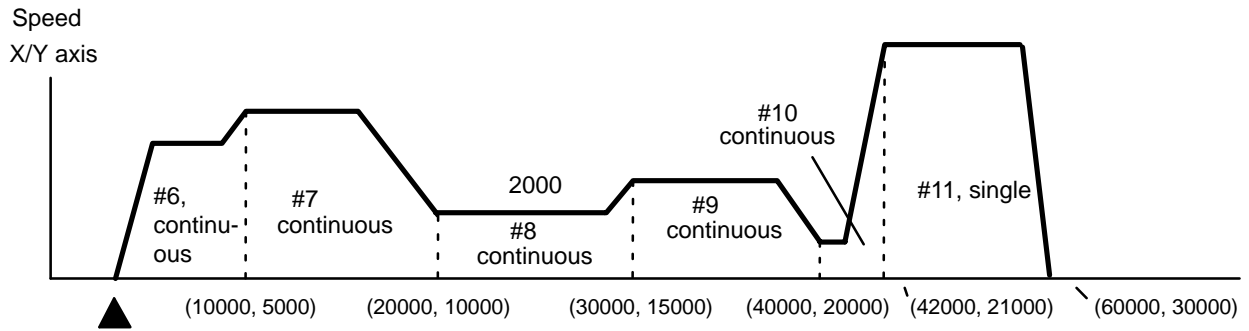
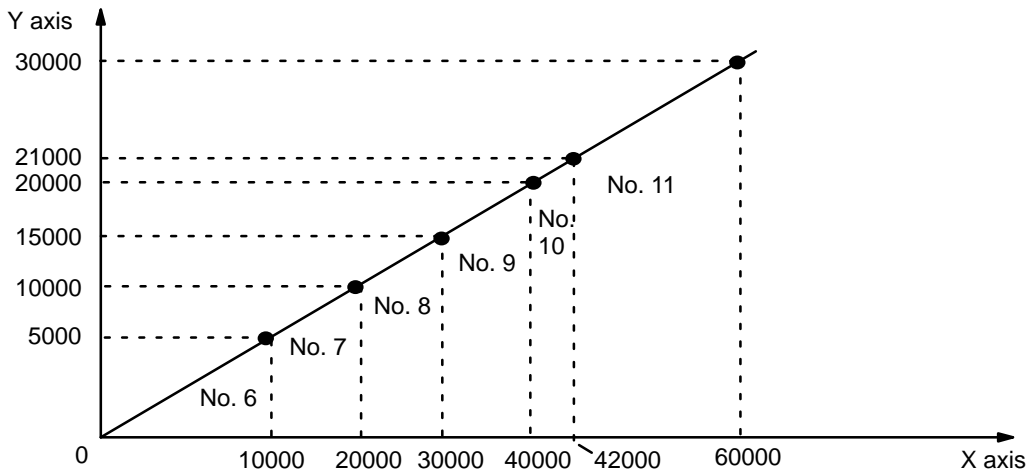

9-8 Example 8

Setting Speed

Multiplying the Speed Unit By 10

This example uses Unit no. 0 and the X axis.

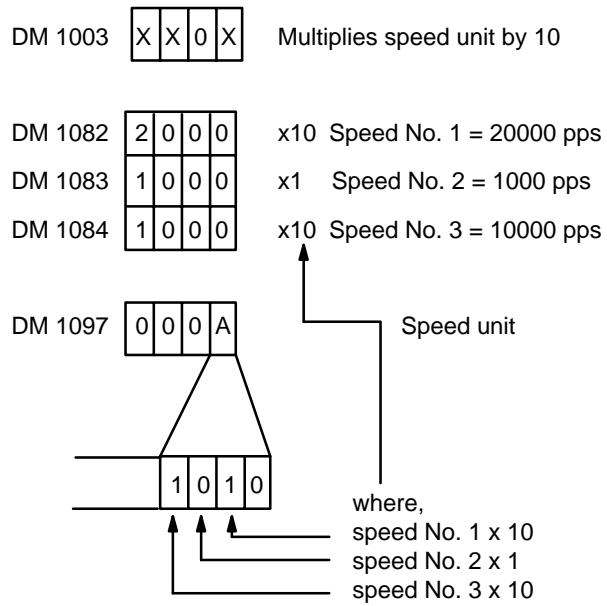

Multiplying the Speed Unit By 100

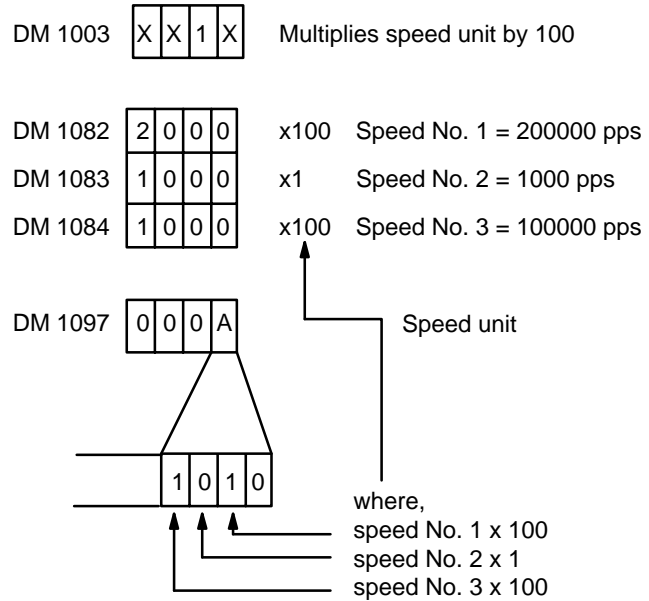

9-9 Example 9

Changing the Target Speed Coefficient

Turning ON switches 1 through 3 during operation before a positioning action is started changes the target speed coefficient, and thus the speed of operation. This example use Unit no. 0 and the X axis for the purpose of illustration.

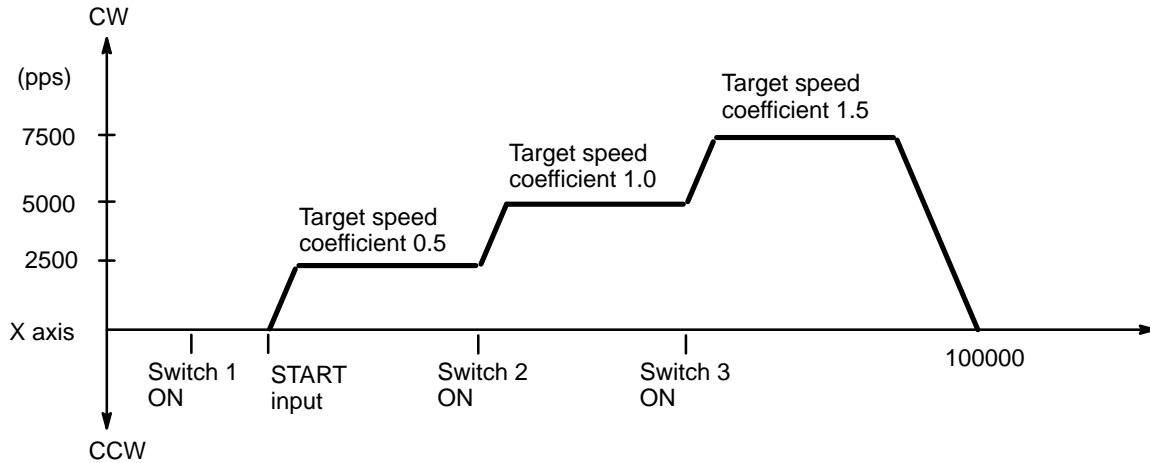

DM Area Settings

DM 1000	1	0	0	0	ORIGIN RETURN speed 1 to F	Initial speed 0 to F	Initial position no. 0 to 52	
DM 1001	1	2	1	2				HIGH-SPEED JOG 1 to F
DM 1022	1	0	0	0	Speed No. 1 to F	Output code 0 to F	Dwell time 0 to F	Comple-tion code 0 to 5
DM 1023	0	0	0	0				
DM 1024	0	1	0	0				
DM 1082	5	0	0	0	Speed #1			
DM 1083	0	5	0	0	Speed #2			
DM 1097	0	0	0	0	Speed units			
DM 1098	0	0	0	8	Acceleration			
DM 1099	0	0	0	8	Deceleration			

Program

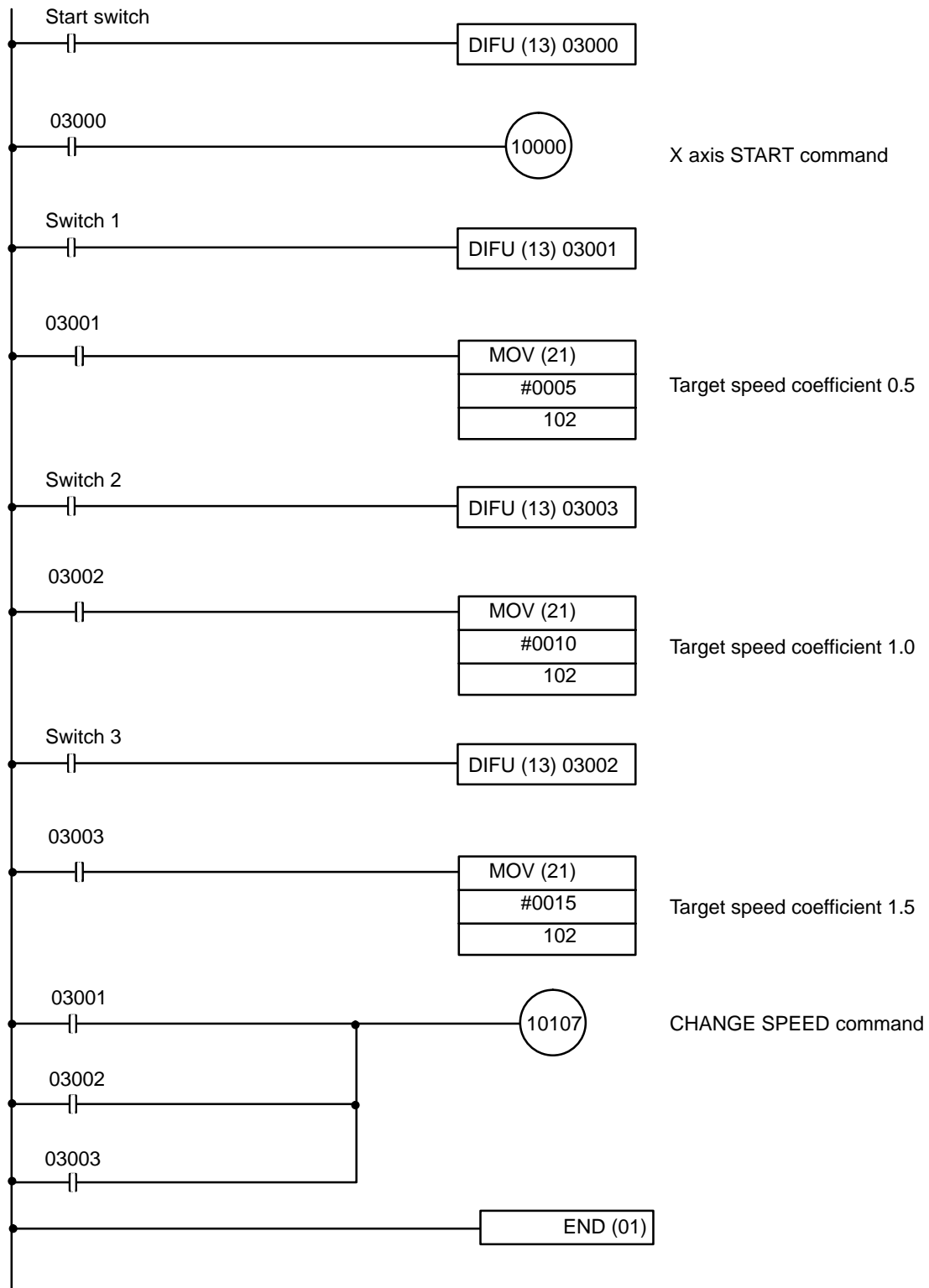

Note The START and CHANGE SPEED commands cannot be executed during the same scan.

9-10 Example 10

Changing Positioning Actions and Using TRANSFER DATA with START

DM Area Settings for the X Axis

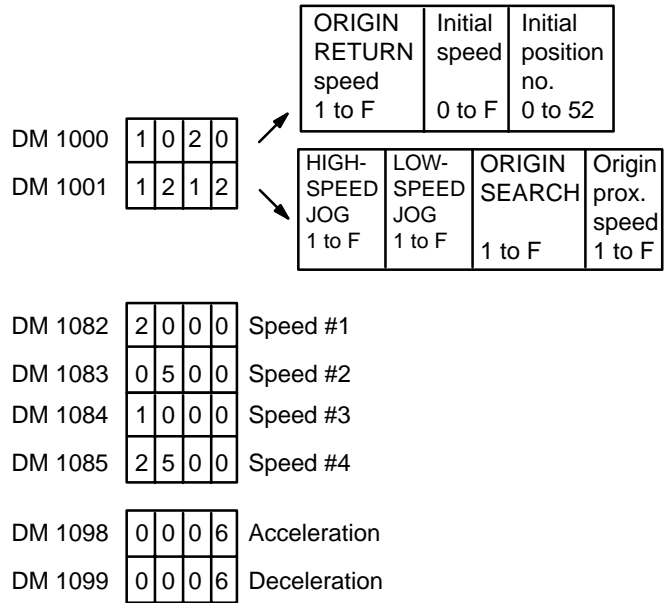

DM Area Settings for the Y Axis

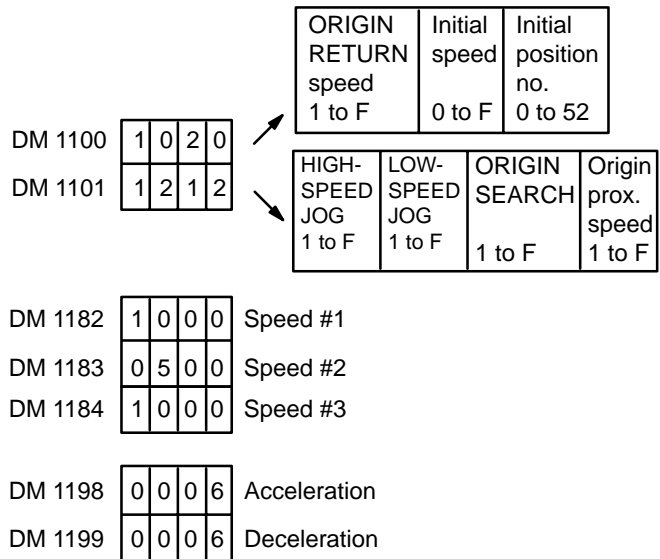

Note Although the speeds, acceleration, and deceleration for the Y axis are ignored during interpolation, this data must be input to prevent generation of an alarm.

X Axis Positioning Data

DM 0100	1	0	0	1
Positioning action no. 20	0	0	0	0
	6	0	0	1
DM 0103	1	0	0	1
Positioning action no. 21	0	0	0	0
	6	0	0	0
DM 0106	2	0	0	1
Positioning action no. 22	0	0	0	0
	7	0	0	1
DM 0109	2	0	0	1
Positioning action no. 23	0	0	0	0
	7	0	0	0

DM 0112	3	0	0	1
Positioning action no. 24	0	0	0	0
	6	0	0	1
DM 0115	3	0	0	1
Positioning action no. 25	0	0	0	0
	6	0	0	0
DM 0118	4	0	0	1
Positioning action no. 26	0	0	0	0
	7	0	0	1
DM 0121	4	0	0	1
Positioning action no. 27	0	0	0	0
	7	0	0	0

DM 0124	3	0	0	1
Positioning action no. 28	0	0	0	0
	6	0	0	1
DM 0127	1	0	0	3
Positioning action no. 29	0	0	0	0
	7	0	0	1

Back Panel Switch Settings

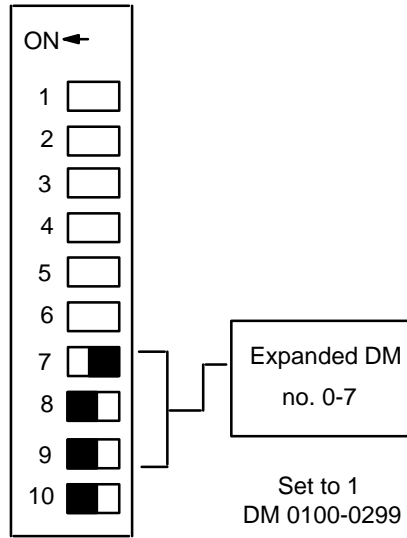

Note Within the C200H DM area (DM 0000-1999), DM 0000 to DM 0999 are read/write addresses. DM 1000-1999 is read-only memory. The MOV command can rewrite the contents of DM 0000-0999, but not contents of DM 1000-1999.

Y Axis Positioning Data

DM 0200	1	0	0	1
Positioning action no. 20	0	0	0	0
	2	0	0	0
DM 0203	1	0	0	1
Positioning action no. 21	3	0	0	0
	2	0	0	0
DM 0206	2	0	0	1
Positioning action no. 22	0	0	0	0
	2	0	0	0
DM 0209	2	0	0	1
Positioning action no. 23	3	0	0	0
	2	0	0	0

DM 0212	3	0	0	1
Positioning action no. 24	0	0	0	0
	2	0	0	0
DM 0215	3	0	0	1
Positioning action no. 25	3	0	0	0
	2	0	0	0
DM 0218	1	0	0	1
Positioning action no. 26	0	0	0	0
	2	0	0	0
DM 0221	1	0	0	1
Positioning action no. 27	3	0	0	0
	2	0	0	0

DM 0224	3	0	0	1
Positioning action no. 28	0	0	0	0
	2	0	0	0
DM 0227	3	0	0	3
Positioning action no. 29	2	0	0	0
	3	0	0	1

Operation

During XY interpolation, the user program changes the X axis data, which is then sent to the NC buffer. After START is executed the data transferred to the buffer is reinitialized.

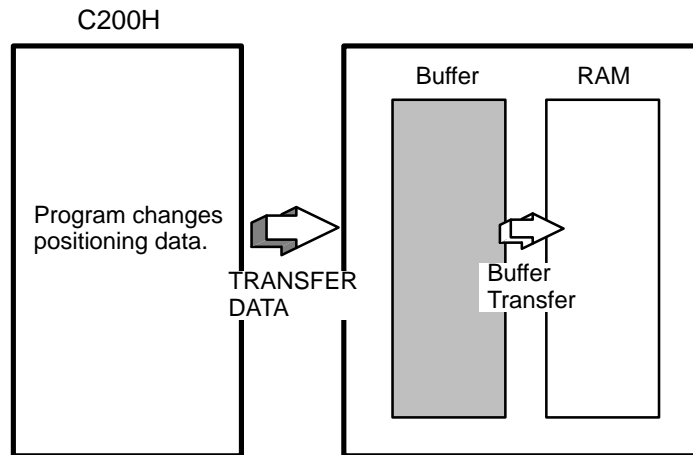

TRANSFER DATA can be executed whether the data flag is ON or OFF. Buffer transfer can be done only when the busy flag is OFF.

Program

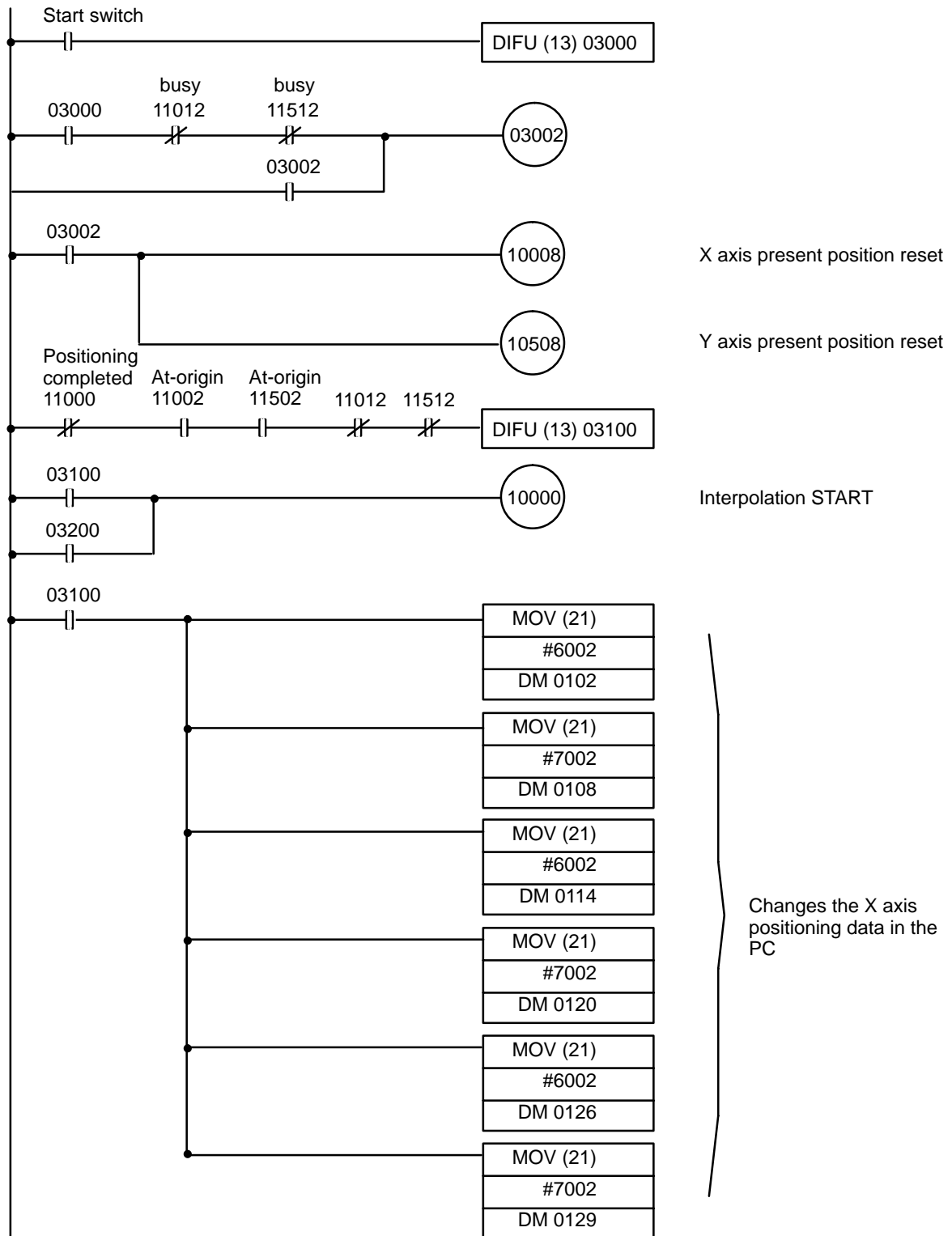

(continues on next page)

(continued from previous page)

Transfers positioning data from the PC to the NC

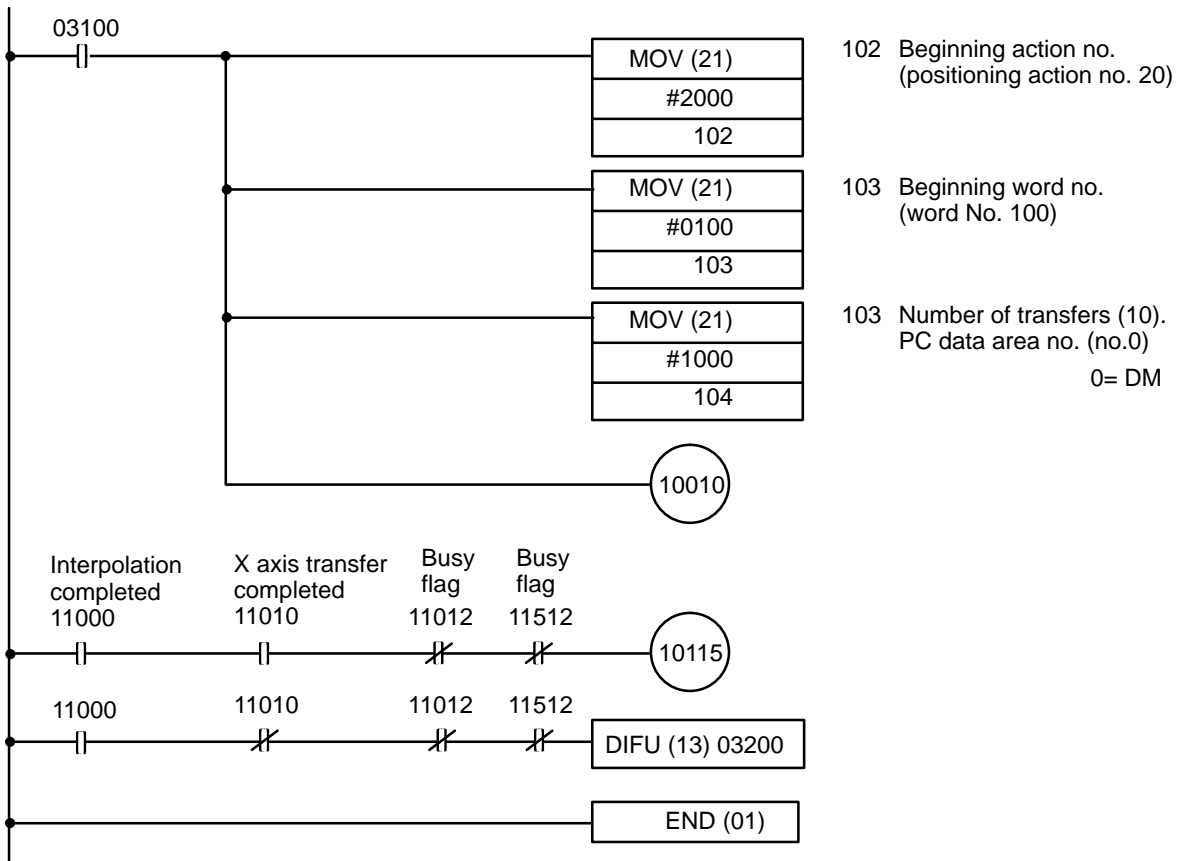

Flag Status

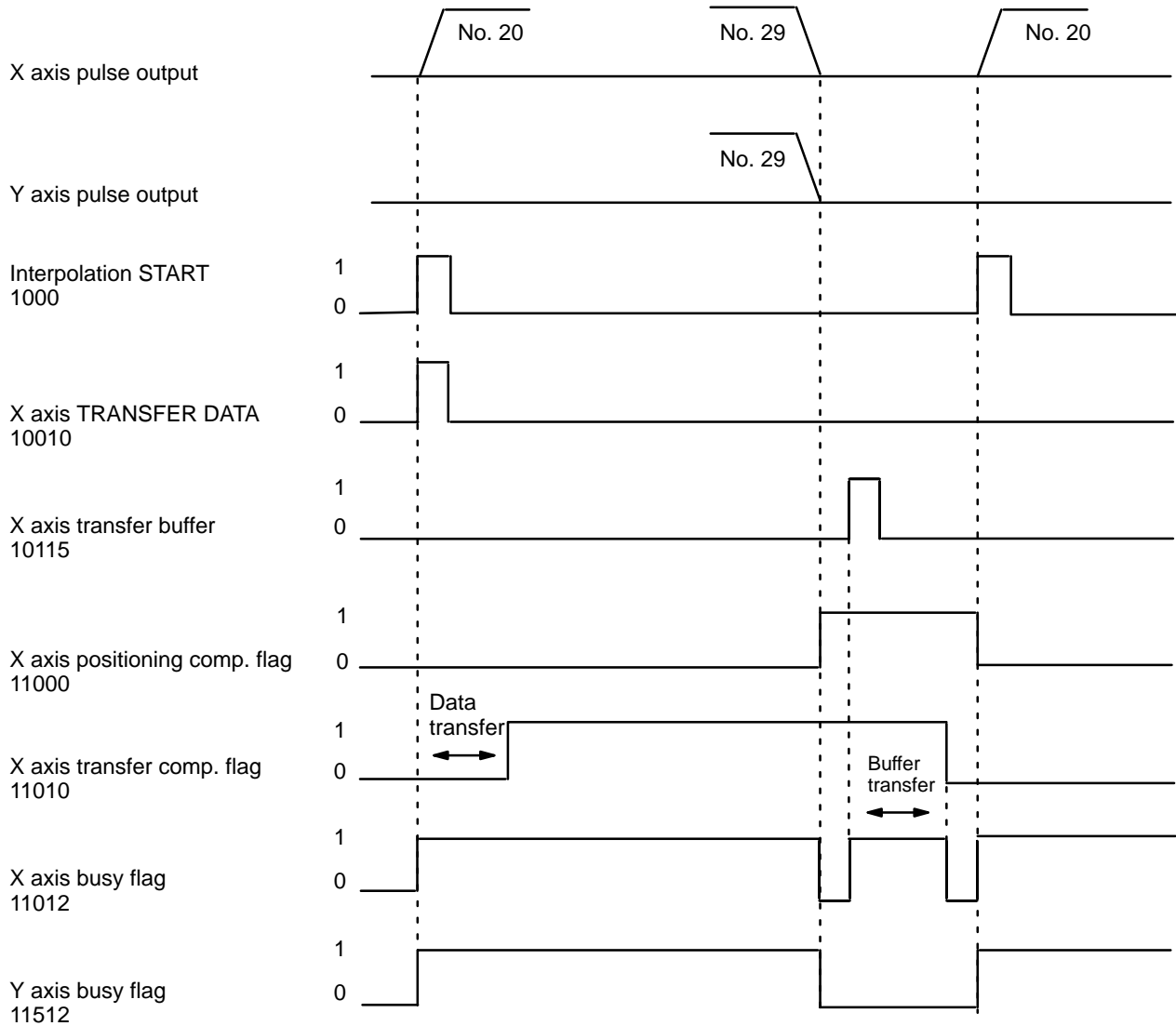

Operating Patterns

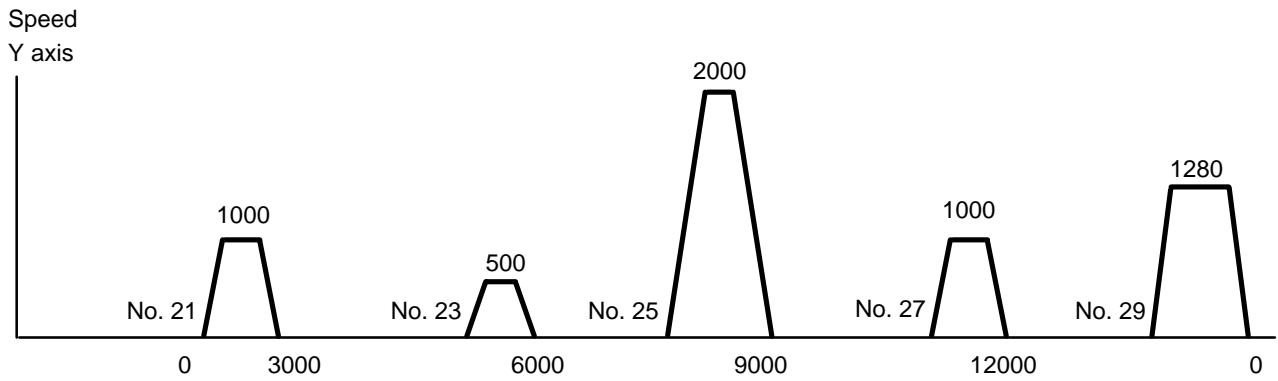
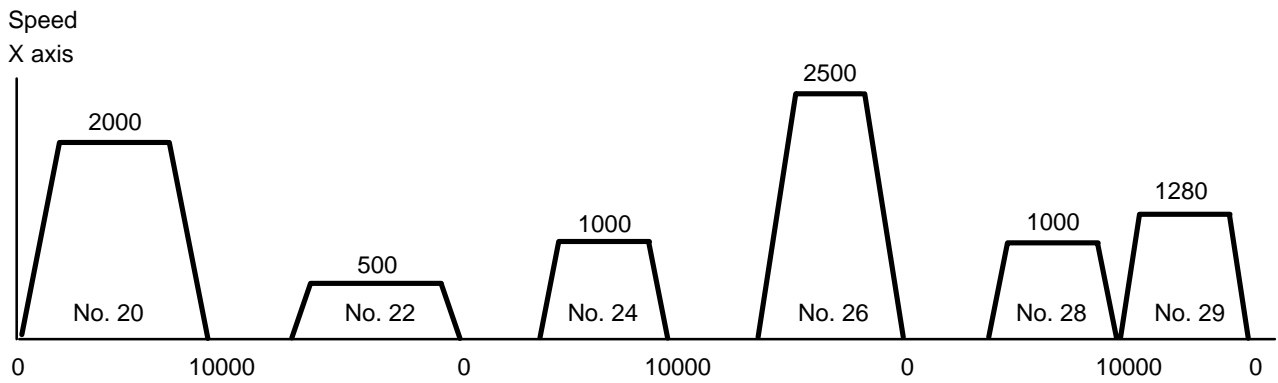
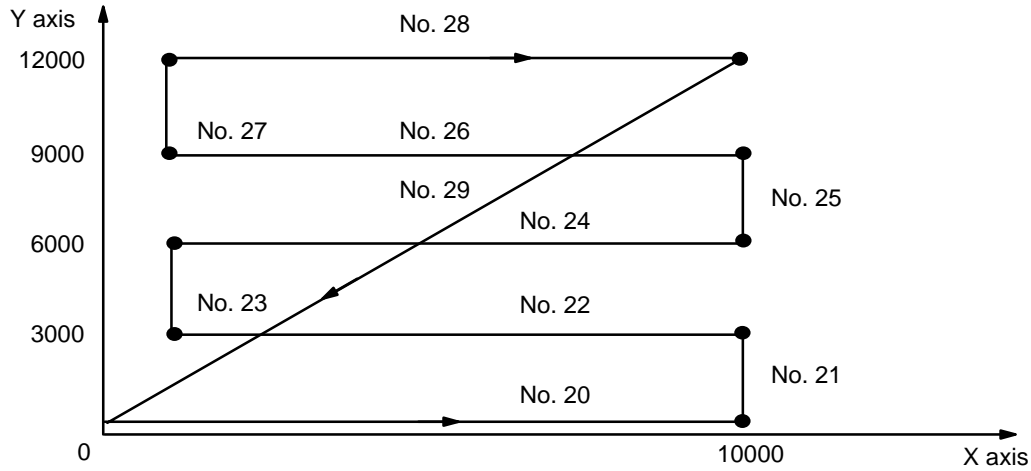

(after TRANSFER has been started)

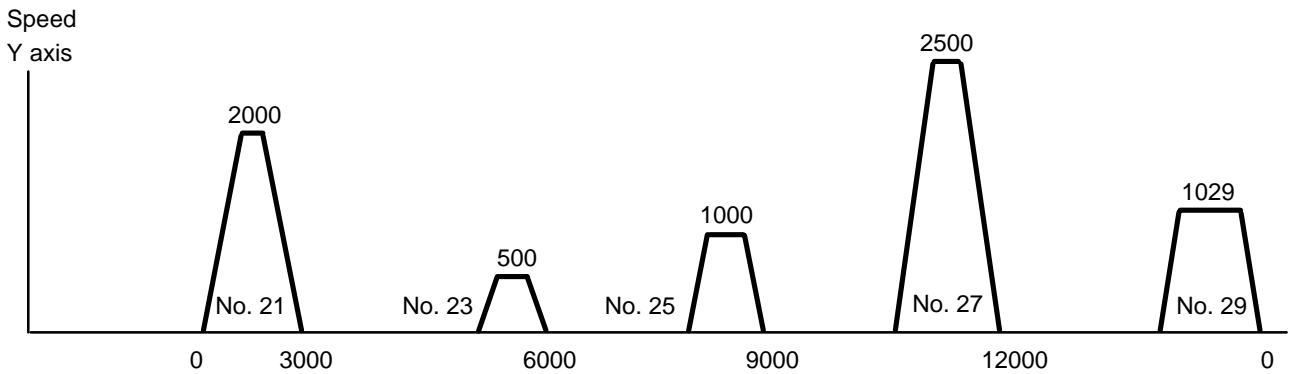
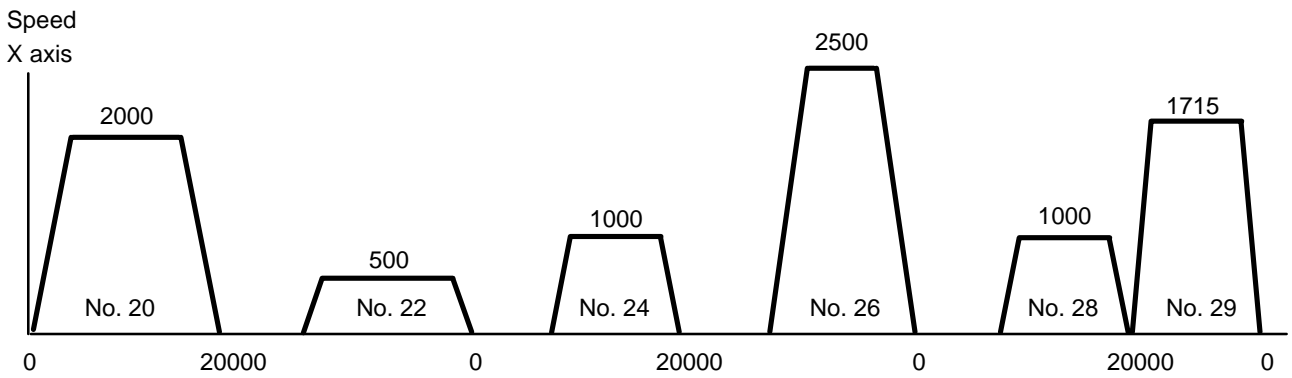
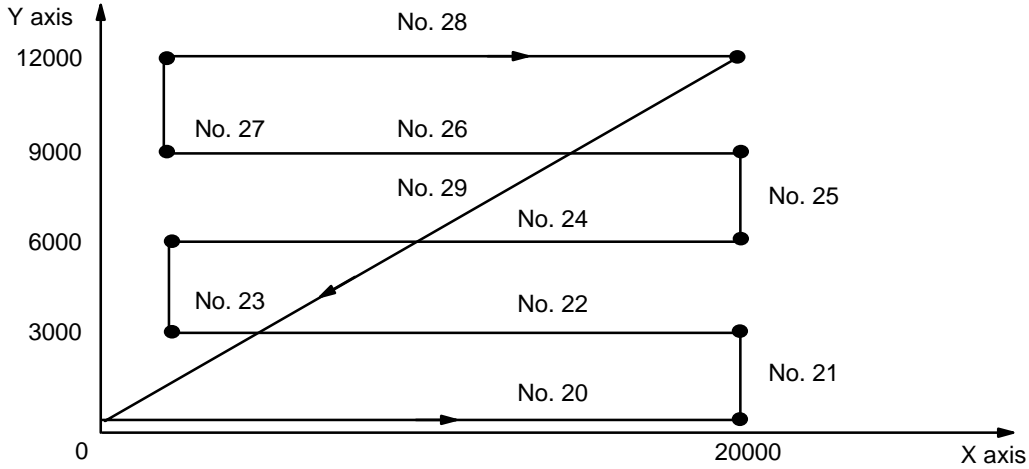

9-11 Example 11

Using a Multiple Bank Program

In this example, it is assumed that the data from Example 4 has already been input to Unit #0.

First Bank (X axis) (Positioning Action Numbers 0 to 2)

The data for first bank is entered into positioning action numbers 0, 1, and 2.

DM 1022	3	0	0	2
Positioning action no. 0	0	0	0	0
	0	0	0	1
DM 1025	4	0	0	0
Positioning action no. 1	5	0	0	0
	0	0	0	1
DM 1028	3	0	0	3
Positioning action no. 2	0	0	0	0
	0	0	0	0

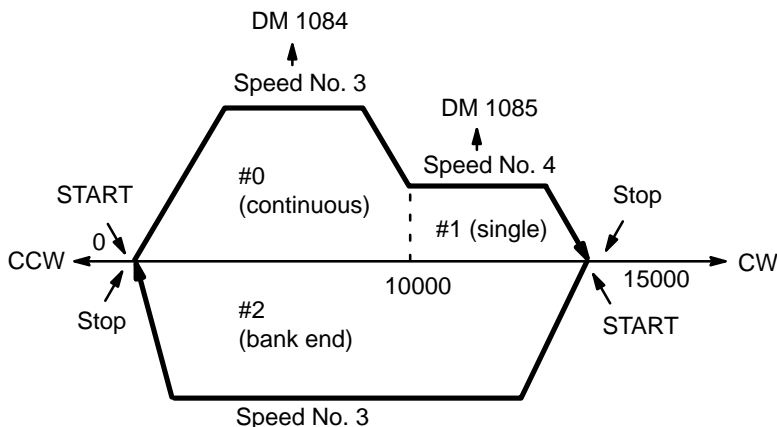

First Bank (X axis) (Positioning Action Numbers 5 to 7)

The data for the second bank is entered into positioning action numbers 5, 6, and 7.

DM 1037	3	0	0	2
Positioning action no. 5	9	0	0	0
	0	0	0	0
DM 1040	4	0	0	0
Positioning action no. 6	5	0	0	0
	0	0	0	1
DM 1043	3	0	0	3
Positioning action no. 7	1	0	0	0
	0	0	0	0

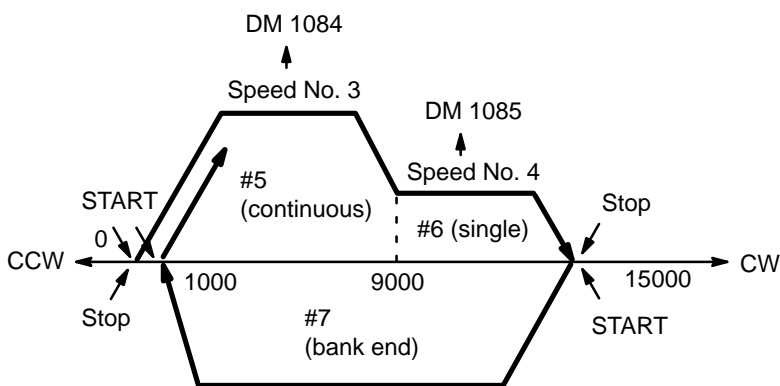

**First Bank (Y axis)
(Positioning Action
Numbers 0 to 2)**

The data for first bank is entered into positioning action numbers 0, 1, and 2.

DM 1122	3	0	0	2
Positioning action no. 0	0	0	0	0
	0	0	0	1
DM 1125	4	0	0	0
Positioning action no. 1	5	0	0	0
	0	0	0	1
DM 1128	3	0	0	3
Positioning action no. 2	0	0	0	0
	0	0	0	0

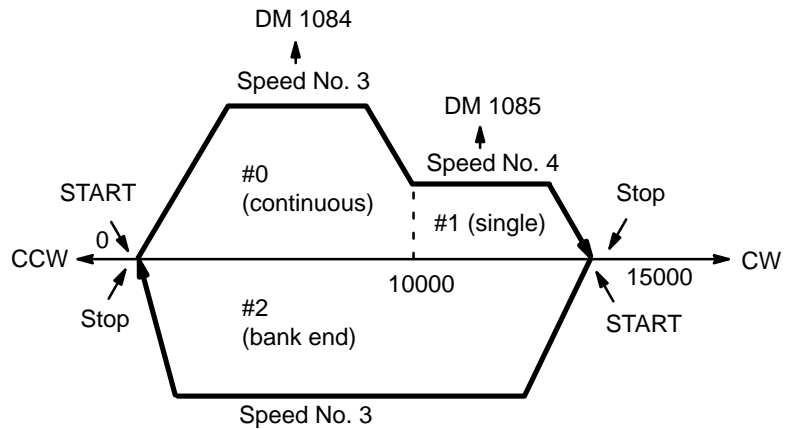

**First Bank (Y axis)
(Positioning Action
Numbers 5 to 7)**

The data for the second bank is entered into positioning action numbers 5, 6, and 7.

DM 1137	3	0	0	2
Positioning action no. 5	9	0	0	0
	0	0	0	0
DM 1140	4	0	0	0
Positioning action no. 6	5	0	0	0
	0	0	0	1
DM 1143	3	0	0	3
Positioning action no. 7	1	0	0	0
	0	0	0	0

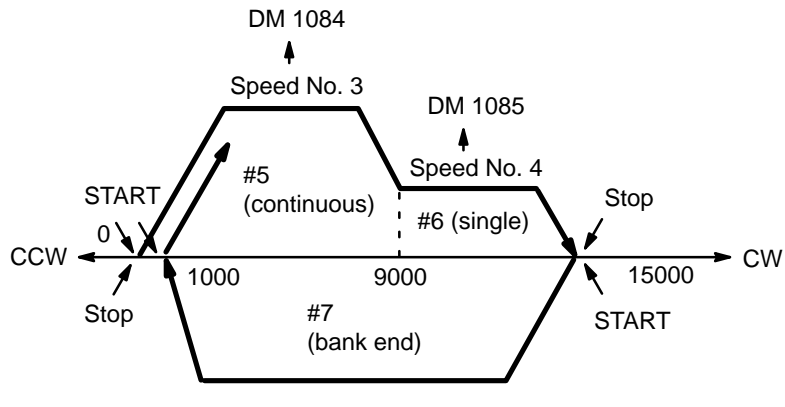

Program (Unit #0)

This program distinguishes between the two banks shown on the previous two pages (for either the X or Y axis). The program selects and execute either positioning action #0 or #5, it turns the valid bit of the initial positioning number ON, then immediately OFF. To force execution, leave the initial positioning action valid bit ON.

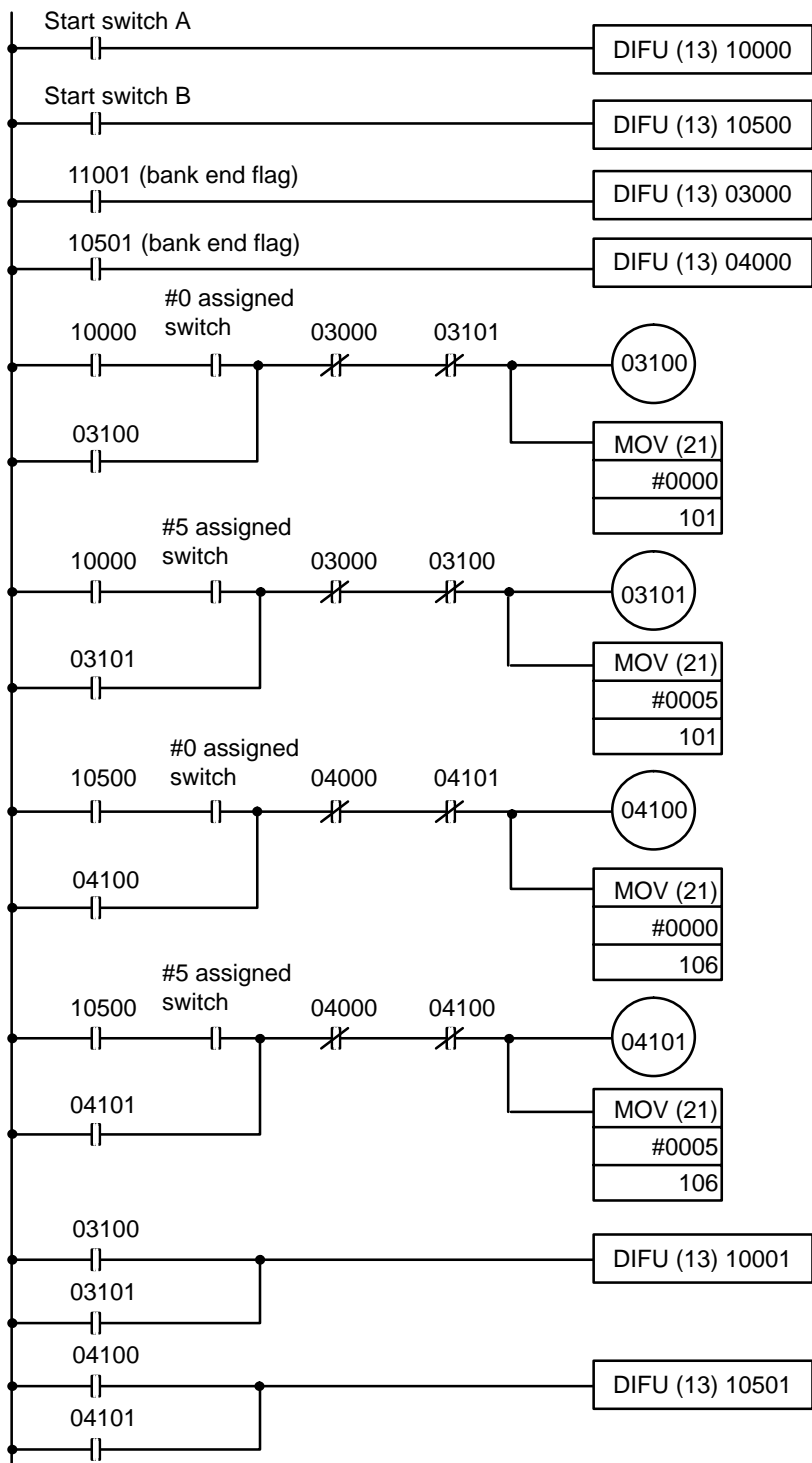

Designates #0 as the next positioning action after the bank ends.

Designates #5 as the next positioning action after the bank ends.

Turns ON the valid initial positioning no. flag for 1 scan with the next START following the end of the bank.

Appendix A

Application in CS1-series PCs

Precautions for Application in CS1-series PCs

Observe the following precautions when using the C200H-NC211 in a CS1-series PC.

Changes in IR/CIO Area and DM Area Allocation

- In C200H-series PCs, the allocated IR Area begins with word $n = 100 + 10 \times \text{unit number}$.
In CS1-series PCs, the allocated CIO Area begins with word $n = 2000 + 10 \times \text{unit number}$.
- In C200H-series PCs, the allocated DM Area begins with word $m = \text{DM } 1000 + 100 \times \text{unit number}$.
In CS1-series PCs, the allocated CIO Area begins with word $m = \text{DM}20000 + 100 \times \text{unit number}$.

DATA TRANSFER through a Data Area

The following table shows how to specify the data area region that will contain the position data and speed data. The leading address of this region is specified in words $n+3$ and $n+4$ (X axis) or $n+8$ and $n+9$ (Y axis).

Specifying the Data Area Words Containing Position and Speed Data

$n = 2000 + 10 \times \text{unit number}$

Data area	Specifiable addresses in CS1-series PCs (See note 1.)	Specifying the DATA TRANSFER region	
		Data area (2-digit BCD) X axis: $n+4$ bits 00 to 07 Y axis: $n+9$ bits 00 to 07	Leading address (4-digit BCD) X axis: $n+3$ bits 00 to 15 Y axis: $n+8$ bits 00 to 15
DM Area (general-purpose area)	DM00000 to DM00999	00	0000 to 0999
DM Area (Special I/O Unit area)	DM20000 to DM20999	00	1000 to 1999 (See note 2.)
CIO Area (I/O Area)	CIO0000 to CIO0255	01	0000 to 0255
CIO Area (Link Area)	CIO1000 to CIO1063	02	0000 to 0063
HR Area 1	HR000 to HR099	03	0000 to 0099
HR Area 2	HR100 to HR127 (Word HR101 cannot be specified)	04	0000 to 0027 (Address 0001 cannot be specified)

- Note**
1. CS1 data area addresses that are not listed in the table cannot be specified.
 2. When specifying words in the DM area that are allocated to Special I/O Units (DM20000 to DM20999), you must specify word addresses used for the Special I/O Unit area in C200HX/HG/HE, C200HS, and C200H PCs (1000 to 1999) rather than the CS1-series word addresses (20000 to 20999).

Expanded DM Area (I to I+199) Settings

Part of the DM Area can be allocated for expanded positioning data storage with DIP Switch pins 7 to 9. The following table shows the expanded DM area specified with the 7 possible settings (binary) of these three pins. (Pin 7 is 2^0 , pin 8 is 2^1 , and pin 9 is 2^2 .)

Settings on pins 7 to 9	Expanded DM area
1	D00100 to D00299
2	D00200 to D00399
3	D00300 to D00499
4	D00400 to D00599
5	D00500 to D00699
6	D00600 to D00799
7	D00700 to D00899

Data Configuration

Allocated CIO Area

$n = 2000 + 10 \times \text{unit number}$

X axis	Y axis	15	0	Content	Direction
n to n+4	n+10 to n+14	Commands from CPU Unit		START, ORIGIN SEARCH, TRANSFER DATA, etc.	CPU → C200H-NC211
n+5 to n+9	n+15 to n+19	Position	Control Unit status	Present position, zones, error flags, etc.	C200H-NC211 → CPU

Allocated DM Area

$M = \text{DM}20000 + 100 \times \text{unit number}$

X axis	Y axis	15	0	Content	Direction
m to m+20	m+100 to m+120	Parameters		Initial position no., Initial speed no., Backlash compensation	CPU → C200H-NC211
m+22 to m+81	m+122 to m+181	Positioning data		Positioning action data #0 to #19	CPU → C200H-NC211
m+82 to m+99	m+182 to m+199	Speed and Acceleration/Deceleration data		Speed #0 to #15 data, Acceleration data, Deceleration data	CPU → C200H-NC211

Expanded DM Area for Positioning Action Data

$I = \text{DM}00100 + 200 \times \text{unit number}$

X axis	Y axis	15	0	Content	Direction
I to I+99	I+100 to I+199	Positioning data		Positioning action data #20 to #52	CPU → C200H-NC211

Operating Procedures

Initial Settings (Hardware)

- 1, 2, 3...**
1. Set the unit number (Machine no.) and operation mode with the rotary switches on the Position Control Unit's front panel. Refer to 2-2 *Switch Settings* for details.
 2. Set the DIP switch on the Position Control Unit's back panel to select the output pulse format, external interrupt signal, external interrupt function, and Expanded DM Area settings. Refer to 2-2 *Switch Settings* for details.
 3. Install the Position Control Unit in a CS1 CPU Rack, C200H Expansion I/O Rack, CS1 Expansion Rack, or SYSMAC Bus Remote Slave I/O Rack. Up to 5 Units can be mounted in a basic system. (The mounting location is not restricted.)
 4. Connect the I/O connector.
 5. Connect a Programming Device to the PC.
 6. Turn ON the PC's power supply.
 7. Create the I/O table.

Initial Settings (Software)

- 1, 2, 3...**
1. Set the parameters, position, speed, and acceleration/deceleration data in the allocated DM area (m to m+99.)
 2. If the allocated DM area (m to m+99) isn't large enough to contain all of the position, speed, and acceleration/deceleration data, set the extra position data in the Expansion DM Area. (The first ad-

dress of the Expansion DM Area is set with pins 7, 8, and 9 of the DIP switch on the back of the Position Control Unit.)

3. Turn the power supply OFF and ON again or turn the Unit's Restart Bit OFF and ON again.

TRANSFER DATA Command

This command can be used during operation if it is necessary to change the position, speed, and acceleration/deceleration data that was set in the initial settings.

- 1, 2, 3... 1. Turn the TRANSFER DATA Bit (bit 10 of n or n+5) from OFF to ON to transfer the data in the specified words (specified in words n+3 and n+4 or n+8 and n+9) beginning with the specified beginning transfer number (00 to 58, specified in bits 08 to 14 of n+2 or n+7.)
2. When the data transfer operation is completed, turn the BUFFER TRANSFER Bit (bit 15 of n+1 or n+6) from OFF to ON to execute the buffer transfer operation.

Note If the buffer transfer is not executed after the data transfer, the data cannot be used as positioning data. The buffer transfer operation is an internal process that transfers the data from the CPU Unit's data exchange buffer to the RAM area used for operation.

START Command

- 1, 2, 3... 1. Use an instruction such as MOV(021) to set the initial positioning action number in bits 00 to 06 of n+1 or n+6.
2. Use an instruction such as OUT to turn the START Bit (bit 00 of n or n+5) from OFF to ON.

Programming Considerations

Transferring Data to the Expanded DM Area

- 1, 2, 3... 1. Program the Busy Flag (bit 12 of n+10 or n+15) as a normally closed input condition and use an instruction such as MOV(021) to set the data transfer area information (parameters defining the data transfer area) in n+3 and n+4 or n+8 and n+9.
2. Use the same input condition from step 1 and use an instruction such as OUT to turn the TRANSFER DATA Bit (bit 10 of n or n+5) from OFF to ON.
3. Program the Transfer Completed Flag (bit 10 of n+10 or n+15) as a normally open input condition and the Busy Flag (bit 12 of n+10 or n+15) as a normally closed input condition and use an instruction such as OUT to turn the BUFFER TRANSFER Bit (bit 15 of n+1 or n+6) from OFF to ON.

Setting Data in the Allocated DM Area and Starting Operation

Program the Busy Flag (bit 12 of n+10 or n+15) as an input condition and use an instruction such as MOV(021) to set the initial positioning action number in bits 00 to 06 of n+1 or n+6. At the same time, turn the START Bit (bit 00 of n or n+5) and Enable Initial Positioning Action Number Bit (bit 01 of n or n+5) from OFF to ON.

Programming Examples

Two-axis Operation (Point-to-Point Operation)

Start operation after performing an ORIGIN SEARCH, Present Position Reset, or Present Position Preset operation on both axes.

Example 1: Independent Two-axis Operation

Operation

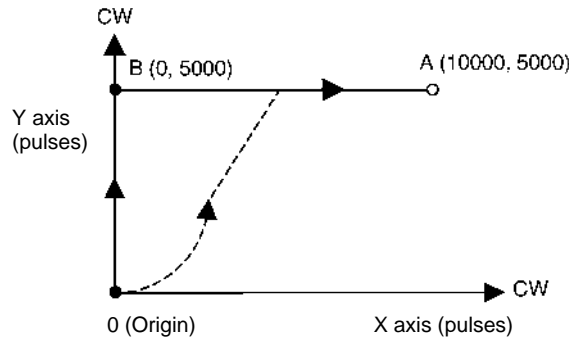

This example program performs positioning from the origin (0, 0) to point B (0, 5,000) with independent Y-axis operation and performs positioning from point B (0, 5,000) to point A (10,000, 5,000) with independent X-axis operation.

The Y-axis' Positioning Completed Flag (bit 00 of n+15) is used to start the X-axis operation.

If both axes are started simultaneously with the same DM Area settings, the X axis starts first and the Y-axis startup will be delayed by 10 to 50 ms while internal startup processing is being performed. (The dashed line shows simultaneous operation of both axes.)

DM Area Settings

X axis		Y axis		ORIGIN RETURN				
Parameter	Bit 3	Bit 2	Bit 1	Bit 0	speed no. (1 to F)	Initial speed no. (0 to F)	Initial position no. (0 to 52)	
D20000	1	0	0	0	HIGH-SPEED JOG speed no. (1 to F)	LOW-SPEED JOG speed no. (1 to F)	Origin Search high speed no. (1 to F)	
D20001	1	2	1	2				Origin Search prox. speed no. (1 to F)
Positioning action data #0								
D20022	1	0	0	3	Target speed no. (1 to F)	Output code (0 to F)	Dwell time (0 to F)	
D20023	0	0	0	0				Completion code (0 to F)
D20024	0	0	0	1				
Target position								
Speed data #1								
D20082	1	0	0	0	Speed data #2			
D20083	0	1	0	0				
Acceleration data								
D20098	0	0	0	5	Deceleration data			
D20099	0	0	0	5				

Ladder Program Examples

• Operating One Axis at a Time

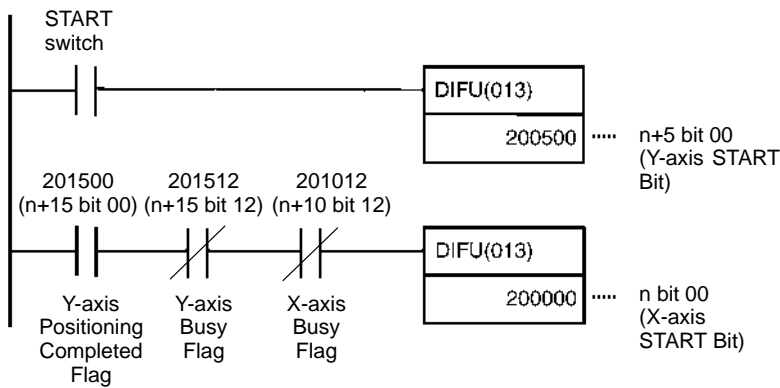

When the START switch goes ON, the Y-axis START Bit (bit 00 of n+5) is turned ON for one cycle.

When the Y-axis Positioning Completed Flag (bit 00 of n+15) goes ON, the X-axis START Bit (bit 00 of n) is turned ON for one cycle as long as the X-axis and Y-axis Busy Flags are both OFF.

• Operating Both Axes Simultaneously

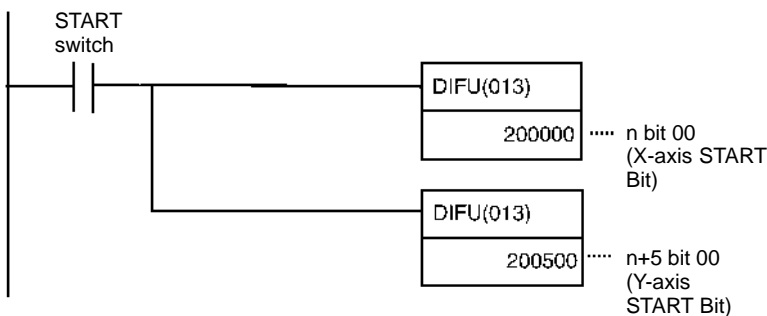

When the START switch goes ON, the X-axis START Bit (bit 00 of n) and Y-axis START Bit (bit 00 of n+5) are turned ON for one cycle.

Note When both axes are started at the same time, the X axis starts first and the Y-axis startup will be delayed by 10 to 50 ms while internal startup processing is being performed.

Example 2: Interpolation (Operating One Axis at a Time)

Operation

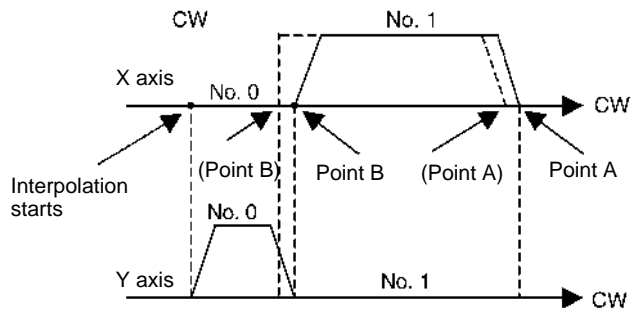
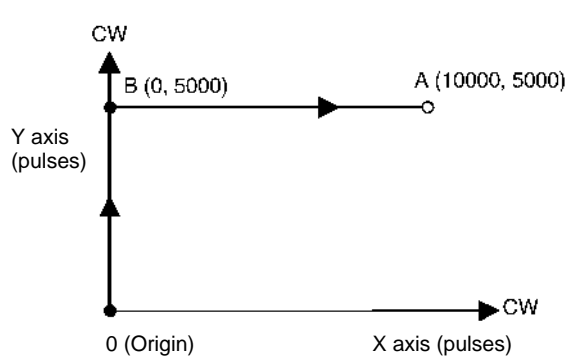

Interpolation can be used to perform the same operation as example 1. There are more DM Area settings with interpolation operation, but there is less ladder programming.

The completion code in DM01022 changes from 1 (Single) to 2 (Continuous), allowing continuous operation (indicated by the dashed lines in the diagram). For interpolation START, use X axis START.

DM Area Settings

X axis		Y axis		ORIGIN RETURN			
D20000	1 0 0 0	D20100	1 0* 0* 0*	Initial speed no. (0 to F)	Initial position no. (0 to 52)		
D20001	1 2 1 2	D20101	1 2 1 2	HIGH-SPEED JOG speed no. (1 to F)	LOW-SPEED JOG speed no. (1 to F)	Origin Search high speed no. (1 to F)	
				Origin Search prox. speed no. (1 to F)			
				Positioning action data #0			
D20022	1 0 0 1	D20122	1* 0* 0* 1	Target speed no. (1 to F)	Output code (0 to F)	Dwell time (0 to F)	Completion code (0 to F)
D20023	0 0 0 0	D20123	5 0 0 0	Target position			
D20024	4 0 0 0	D20124	0 0 0 0	Positioning action data #1			
D20025	1 1 0 3	D20125	1* 1* 0* 3				
D20026	0 0 0 0	D20126	0 0 0 0				
D20027	4 0 0 1	D20127	0 0 0 0				
				*Speed data #1			
D20082	1 0 0 0	D20182	1 0 0 0	*Speed data #2			
D20083	0 1 0 0	D20183	0 1 0 0				
				*Acceleration data			
D20098	0 0 0 5	D20198	0 0 0 5	*Deceleration data			
D20099	0 0 0 5	D20199	0 0 0 5				

Ladder Program Example

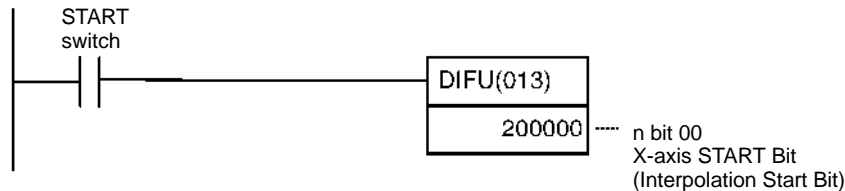

Interpolation Settings

When the direction of the X axis positioning action is set to a value between 4 and 7, the settings are interpreted as interpolation data. The speed, acceleration, deceleration, output code, and dwell time settings for interpolation are determined by the X axis values only. Y axis settings (marked with an asterisk *) are ignored, but data must be input to prevent an alarm from being generated.

Example 3: Linear Interpolation

This example program performs positioning from the origin (0, 0) to point A (10000, 5000) using linear interpolation. The speed of interpolation is determined by the speed set for the X axis.

Operation

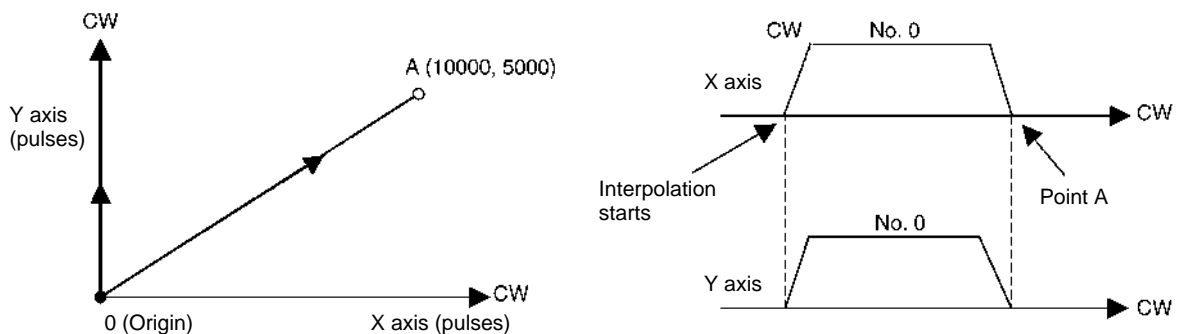

DM Area Settings

X axis

Y axis

D20000	1	0	0	0
D20001	1	2	1	2

D20100	1	0*	0*	0*
D20101	1	2	1	2

to

to

D20022	1	0	0	3
D20023	0	0	0	0
D20024	4	0	0	1

D20122	1*	0*	0*	3
D20123	5	0	0	0
D20124	0	0	0	0

D20082	1	0	0	0
D20083	0	1	0	0

D20182	1	0	0	0	*
D20183	0	1	0	0	*

D20098	0	0	0	5
D20099	0	0	0	5

D20198	0	0	0	5	*
D20199	0	0	0	5	*

ORIGIN RETURN speed no. (1 to F)	Initial speed no. (0 to F)	Initial position no. (0 to 52)	
-------------------------------------	-------------------------------	--------------------------------	--

HIGH-SPEED JOG speed no. (1 to F)	LOW-SPEED JOG speed no. (1 to F)	Origin Search high speed no. (1 to F)	Origin Search prox. speed no. (1 to F)
--------------------------------------	-------------------------------------	--	---

Positioning action data #0

Target speed no. (1 to F)	Output code (0 to F)	Dwell time (0 to F)	Completion code (0 to F)
------------------------------	-------------------------	------------------------	-----------------------------

Target position			
Direction			

Ladder Program Example

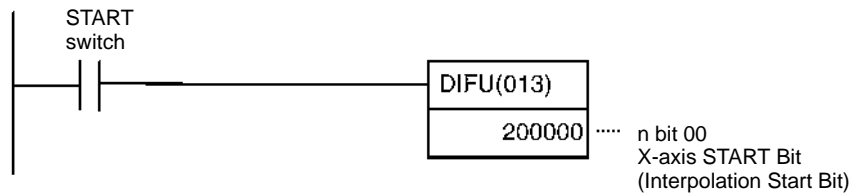

Appendix B

Specifications

General

The unit conforms to C-series specifications.

Performance Specifications

Item		Specification
Number of control axes		2 axes/Unit
Control system		Automatic trapezoidal acceleration/deceleration
Position	Data	-8,388,607 to +8,388,606 pulses
	Data points	53/axis
Speed	Range	1 to 250,000 pps (pulses/second)
	Data points	15
Speed adjustment rate		2 to 2,000 pps/1ms
Origin search		Origin proximity: selectable (absent, N.O. input, or N.C. input). Origin signal: selectable (N.O. input or N.C. input) Origin compensation: 0 to $\pm 9,999$ pulses. Origin search speed: may be set to high speed or proximity speed. Origin search method: may be set to stop upon origin signal after proximity signal has turned ON, or to stop upon receiving the origin signal after the proximity signal has turned OFF. N.O. = Normally open N.C. = Normally closed
Backlash compensation		0 to 9,999 pulses
Manual operation		HIGH-SPEED JOG, LOW-SPEED JOG, INCH
Internal current		500 mA max at 5 VDC (consumption from Rack).
Dimensions (mm)		35 (W) x 130 (H) x 100.5 (D)
Weight		500g max. (excluding connectors)

Input Specifications

Item	Specification
Voltage	12 to 24 VDC $\pm 10\%$
Current	5 mA (at 12 V) to 11 mA (at 24V)
ON voltage	10.2 VDC min.
OFF voltage	3.0 VDC max.
ON response time	1 ms max.
OFF response time	1 ms max.

Origin-signal Input Specifications

Item	Connection Terminal		Specification	Response Time
External signal is open-collector signal	X Axis	10 11	Input current is 6 mA (at 12 V) to 13 mA (at 24 V); other specifications remain the same	Mode 0: < 1 ms
	Y Axis	32 33		Mode 1, 2: < 0.1 ms
External signal is line-driver signal	X Axis	9 11	Signal is a line-driver signal corresponding to Am26LS31	Mode 3: Not used
	Y Axis	31 33		

Output Specifications

Item	Specification
Maximum switching capacity	30 mA at 5 to 24 VDC $\pm 10\%$ (NPN open collector)
Minimum switching capacity	7 mA at 5 to 24 VDC $\pm 10\%$ (NPN open collector)
Leakage current	0.1 mA max.
Residual voltage	0.6 V max.
External power supply	24 VDC +10% (maximum 30 mA)

CW/CCW Pulse Output Specifications

Minimum Pulse Width

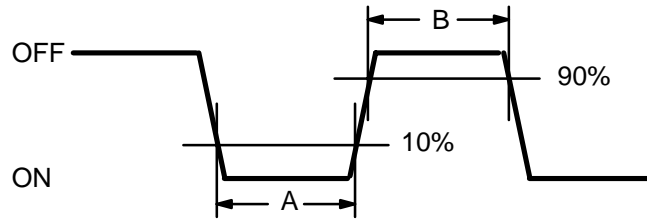

Note: The OFF/ON refers to the transistor.
The output transistor is ON at level "L."

Open or close current/loaded power-source voltage						
Pulse Frequency	$\frac{7-30 \text{ mA}}{5 \text{ VDC} \pm 10\%}$		$\frac{7-30 \text{ mA}}{12 \text{ VDC} \pm 10\%}$		$\frac{7-30 \text{ mA}}{24 \text{ VDC} \pm 10\%}$	
	A	B	A	B	A	B
<50 Kpps	>9.9 μs	>9.5 μs	>9.9 μs	>9.8 μs	>9.9 μs	>9.8 μs
<100 Kpps	>4.6 μs	>4.9 μs	>4.9 μs	>4.8 μs	>4.9 μs	>4.8 μs
<200 Kpps	>2.4 μs	>2.1 μs	>2.4 μs	>2.3 μs	>2.4 μs	>2.4 μs
<250 Kpps	>1.9 μs	>1.5 μs	>1.9 μs	>1.8 μs	>1.9 μs	>1.9 μs

Note Specifications other than those above correspond to the output specifications of the preceding page.

Appendix C

Standard Models

Product Name	Description	Model No.
Position Control Unit	2 Axis	C200H-NC211

Glossary

absolute target position	A target position given in respect to the origin rather than in respect to the present position.
alarm code	A four-digit code which is output to a word in the IR Area to identify the type of alarm which has occurred.
AR area	A PC data area which is used for system flags and status information. Data is retained in this area during a power failure.
backlash compensation	Compensation for the amount of mechanical play, or “looseness,” present in gears. Such play can create positioning inaccuracy when the direction of positioning changes.
bank	A combination of several positioning actions or sequences. A bank begins when START is executed for the initial positioning action and ends when a positioning action with a “bank end” completion code has been executed.
bank end (completion)	A positioning action completion code that designates the positioning action as the final one in a bank.
BCD	An acronym for binary-coded decimal, which refers to decimal numbers encoded in binary notation.
completion code	A parameter for execution of a positioning action that designates what is to happen when that positioning action has been completed. The five possible completion codes are as follows: single, pause, continuous, bank end, extended, and extended with positioning.
continuous (completion)	A positioning action completion code that causes the next positioning action to be executed immediately upon completion of the current one.
CW and CCW	Abbreviations for clockwise (CW) and counterclockwise (CCW). CW and CCW are defined for a motor shaft in reference to a viewer facing the shaft on the end of the motor from which the shaft extends for connection.
CW/CCW limits	Limits on the CW and CCW sides of the origin which can be internally set to restrict Position Control Unit operation.
data area	A memory storage area in the PC. Different types of memory blocks, with differing functions, are stored in the various data areas of the PC. These blocks of memory are built up from single units, or bits, which are grouped into 16-bit words.
DM area	A PC data area in which general operating parameters, speeds, and parameters for positioning actions are stored.
dwel time	A parameter that specifies the period of time during which positioning will stop before execution of the next positioning action following a positioning action with a pause completion code.
error code	A four-digit code which is output to a word in the IR Area to identify the type of error which has occurred.

error counter	A device used to ensure positioning accuracy when positioning via pulse trains. The error counter receives the target position as specific number of pulses in a pulse train from the Position Control Unit and outputs analog speed voltages to drive a servomotor accordingly. The specified number of pulses in the error counter is counted down by feedback from an encoder measuring actual motor shaft movement, causing voltage output to stop when the number of pulses equals zero, i.e., when the target position has been reached.
external interrupt	A function whereby positioning may be stopped or speed may be changed during operation in response to an external command.
flag	A bit that is turned ON and OFF automatically by the system to provide information.
host computer	A computer that is used to transfer data to or receive data from a PC in a Host Link System. The host computer is used for data management and overall system control. Host computers are generally small personal or business computers.
IN refresh area	The last five of the ten IR words allocated to each Position Control Unit as refresh areas.
inching	Manual feeding wherein positioning is executed one pulse at a time.
incremental target position	A target position given in respect to the present position, rather than in respect to the origin.
initial position	The present position when START is executed.
IR Area	A PC data area allocated for inputs and outputs. In the C200H, words 100 through 199 of this area are reserved for Special I/O Units, including the Position Control Unit. The Position Control Unit uses these words for I/O refresh areas.
N.C. contacts	Normally-closed contacts. A pair of contacts on a relay that open when the relay is energized.
N.O. contacts	Normally-open contacts. A pair of contacts on a relay that close when the relay is energized.
open-loop system	A control system in which a particular operation is carried out according to programmed instructions, but in which feedback is not provided for automatic adjustments.
origin	The point which is designated as 0 at any given time.
origin compensation	A parameter used to correct the origin from the position determined according to the origin input signal.
origin proximity signal	A signal input to indicate when the position is near the origin to enable shifting to a lower speed.
origin proximity	The region near the origin. When positioning enters this region, a proximity switch may output a signal for deceleration.
OUT refresh area	The first five of the ten IR words allocated to each Position Control Unit as refresh areas.
output code	User-defined codes output following completion of a positioning action.

parameters	Data which determines limits and other conditions under which an operation will be carried out. The Position Control Unit has both general parameters and parameters specific to individual positioning actions.
pause (completion)	A positioning action completion code that creates a pause after reaching the target position for the positioning action and then automatically begins the next positioning action. The length of the pause is specified by the dwell time.
positioning action	The smallest increment of positioning possible. A positioning action is defined by its completion code, dwell time, output code, speed number, and target position. These actions are generally referred to by number and completion code. For example, "#6, continuous" indicates positioning action #6 with a continuous completion code.
present position	The numeric value in pulses defined as being the 'location' of the positioning system at any one point in time. The present position is not absolute, but rather can be defined or redefined as required by positioning operations.
proximity speed	A low speed at which positioning is executed near the origin.
pulse rate	The distance moved by an object driven by a motor divided by the number of pulses required for that movement.
pulse train	A series of pulses output together.
pulses	Discrete signals sent at a certain rate. The Position Control Unit outputs pulses, each of which designates a certain amount of movement. Such pulses are converted to an equivalent control voltage in actual positioning.
Remote I/O Master Unit	The Unit in a Remote I/O System through which signals are sent to all other Remote I/O Units. The Remote I/O Master Unit is mounted either to a CPU Rack or to an Expansion I/O Rack connected to the CPU Rack.
Remote I/O System	A system in which remote I/O points are controlled through a Master mounted to a CPU Rack or an Expansion I/O Rack connected to the CPU Rack.
Remote I/O Units	Any of the Units in a Remote I/O System. Remote I/O Units include Masters, Slaves, Optical I/O Units, I/O Link Units, and Remote Terminals.
response time	The time it takes for the PC to output a control signal after it has received an input signal. The response time depends on factors such as the system configuration and when the CPU receives the input signal relative to the start of a scan.
scan time	The total time required for the PC to perform all of the operations involved in executing the program in its memory. The duration of the scan time differs depending on the configuration of the system, the number of I/O points, the programming instructions used, and so on.
semiclosed-loop system	A control system in which a PC controls an external process without human intervention. This system provides feedback (via a tachogenerator and a rotary encoder) so that actual values (of positions, speeds, and so on) are continuously adjusted to bring them more closely in line with target values.
servolock	An operation whereby a rotary encoder is used to maintain the position of a motor while it is stopped. Whenever the motor axis moves, the rotary encoder sends a feedback pulse to an error counter, causing a rotation voltage to be generated in the reverse direction so that the motor rotates back to its original position.

Glossary

single (completion)	A positioning action completion code that causes positioning to stop after the target position for the positioning action has been reached.
Special I/O Unit	A dedicated Unit, such as a Position control Unit, High-Speed Counter Unit, or Analog Timer Unit, that is designed for a special purpose.
speed coefficient	An IR Area setting which determines the coefficient with regard to the target speed.
speed number	A number used to designate as a parameter for an operation one of fifteen speeds registered in memory.
speed unit	A bit in the DM Area which can be set to multiply the speed to which it is assigned by a factor of one or ten.
target position	A parameter for a positioning action that designates what position is to be reached at the completion of the action.
teaching	Writing the present position into the DM Area of the PC as the target position for the designated positioning action.
trapezoidal acceleration/deceleration	Accelerating and decelerating in a stepwise pattern such that a trapezoidal figure is formed.
unit numbers	Number assigned to Position Control Units for the purpose of allocating specific I/O words to each unit.
zone	A range of positions which can be defined so that flags are turned ON whenever the present position is within the range. Up to three zones, each with its own flag, can be defined.

Index

A–B

- acceleration, setting for START, 94
- alarms, 170
 - alarm codes, 176, 178
 - alarm flag, 172, 176
 - indicators, 172–187
- AR Area, restart flag, 50
- backlash compensation, setting parameters for, 73
- bank end (completion code), 81
- banks, multiple, 229

C

- C200H-112, differences with C200H-112, 3
- cables, 35, 47
- CCW limits
 - internal, 75
 - recovery from exceeding, 173, 175
- CHANGE SPEED. *See* commands
- CHANGE SPEED COEFFICIENT, 5
- closed-loop systems, 11
- commands, 67
 - CHANGE SPEED, 146–149
 - execution example, 146
 - CHANGE SPEED COEFFICIENT, 147
 - external interrupt, 131–149
 - HIGH-SPEED JOG, 127
 - used to clear CW or CCW limit flag, 175
 - INCH, 129
 - LOW-SPEED JOG, 128
 - manual operations, 125–149
 - IR Area settings, 126–149
 - ORIGIN SEARCH
 - completion examples, 119–124
 - examples in mode 0, 24
 - examples in mode 1, 26
 - examples in mode 2, 28
 - examples in mode 3, 30
 - executed after emergency stop, 174
 - execution examples, 106–124
 - IR Area settings, 105–124
 - READ ERROR, 176–187
 - execution example, 177
 - reading from the Programming Console, 177
 - RELEASE PROHIBIT, 173–187
 - RESET ORIGIN, 130–149
 - execution examples, 196
 - START
 - command bit, 122
 - DM Area settings, 68–96
 - executing positioning actions, 210
 - execution examples, 208, 210

- STOP, 134–149
 - executed during backlash compensation, 73
 - executed during completion code 5, 144
 - executed during HIGH-SPEED JOG, 142
 - executed during LOW-SPEED JOG, 143
 - executed during ORIGIN SEARCH, 140
 - executed during pulse output, 123
 - executed during START, 134
 - execution examples, 136, 137, 138
- TEACH, 151–168
 - execution example, 155–168
 - IR Area settings, 153
 - setting positioning action number, 153
 - teaching from the Programming Console, 156
- TRANSFER DATA, 158–168
 - and trapezoidal tables, 94
 - beginning transfer number, 161
 - beginning word number (for normal transfer), 161
 - beginning word number (present position preset), 166
 - data preparation (normal), 159
 - data preparation (present position preset), 166
 - execution example (normal transfer), 164
 - execution example (preset present position), 168
 - IR Area settings, 161–168
 - normal transfer, 159–168
 - PC data areas available, 159
 - present position preset, 165–168
 - setting PC data area (for normal transfer), 162
 - setting PC data area (present position preset), 167
- completion codes, 79, 80
 - cautions for using continuous completion, 88
 - STOP during completion code 5, 144
- components, 9–16
- connector pins, arrangement, 34
- control system principles, 11–16
- CW limits
 - internal, 75
 - recovery from exceeding, 173, 175

D

- data, writing into DM Area, 50–65
- data coding, 54
- data flow diagram, 12
- data transfer, 2
- deceleration, setting for START, 94
- delay time, 83
- deviation counter reset, 111
 - wiring, 43
- digital-to-analog converters, 11
- dimensions, 48
- DIP switch
 - pins 1 and 4, 23

- pins 2, 5, 3 and 6, 23
- pins 3-7, 23
- pins 7-9, 3
- settings, 9
 - table of, 22
- settings for external interrupt, 132

DM Area

- allocations, 54–65
- coding sheet, 54, 213
- minimum data settings, 191, 208
- positioning data expansion, 3
- settings for START, 68–96
- transferring data from, 51
- writing data into, 50
- writing into with TEACH, 152
- zones, 76

DM area, positioning data expansion, 23

dwelt time, 84, 114

E–F

- emergency stop, 173
 - flag, 175
 - recovery after, 174

emergency stop switch, 173

error counters, 12, 15

errors, 170

- BCD errors, 170
- error code generation, 170
- error code list, 185–187
- error codes, 176, 178
- error flags, 176
 - AR Area, 180
 - IR area, 172
- error list for Special I/O Units, 179–187
- error processing, 169
- indicators, 172
- no-data errors, 170
- out-of-range data errors, 170

extended (completion code), 81

extended with positioning (completion code), 82

external I/O connections, 33

external interrupt commands, 131–149

external interrupt signal, connection for, 132

feedback, 11, 15

flags

- alarm flag, 176
- busy flag, 176
- emergency stop flag, 175
- error flags, 176
 - AR Area, 180
- no-origin flag, 152
- status of, 226

H–M

high speed number, setting for ORIGIN SEARCH, 70

HIGH-SPEED JOG. *See* commands

I/O connections, external, 33

I/O refresh areas, 123

INCH. *See* commands

indicators (LEDs), alarm/error, 172

inductive loads, 47

initial positioning action number, setting for START, 68, 123

initial speed number, setting for START, 69

Input Units, 6

Interpolation, settings, 86

interpolation

- linear, 207
- using STOP during, 139
- with independent axis START, 205

IR Area

- alarm/error outputs, 172
- allocations, 98
- data format, 100
- settings for external interrupt, 133
- settings for manual operations, 126–149
- settings for ORIGIN SEARCH, 105–124
- settings for TRANSFER DATA, 161–168

LOW-SPEED JOG. *See* commands

magnetizing distribution circuits, 12

manual operations. *See* commands

modes

- mode 0
 - connection, 20
 - DIP switch settings (example), 24
 - ORIGIN SEARCH executed in, 106–124
- mode 1
 - connection, 21
 - DIP switch settings (example), 26
 - ORIGIN SEARCH executed in, 110
- mode 2
 - connection, 21
 - DIP switch settings (example), 28
 - ORIGIN SEARCH executed in, 114–124
- mode 3
 - connection, 21
 - DIP switch settings (example), 30
 - ORIGIN SEARCH executed in, 115–124
- mode switch, 20, 24–48

mounting, Position Control Unit to CPU Rack, 8

N–O

N.O. and N.C. inputs, 44
 noise (electronic), prevention, 47
 open-loop systems, 11, 13–16
 origin adjustment command, 117
 wiring, 43
 origin compensation, 119, 120, 121
 setting for ORIGIN SEARCH, 71
 origin proximity reverse, 106, 108, 110, 112, 115, 117
 origin proximity signals, 119, 199
 origin signals, 199
 output code, 84

P

pause (completion code), 80
 positioning accuracy, computation of, 14
 positioning actions
 bank end, 81
 continuous, 80
 errors in data for, 170
 executed with START, 210
 extended, 81
 extended with positioning, 82
 initial positioning action number, 68, 123
 pause, 80
 setting positioning action number for TEACH, 153
 single, 80
 power amplifiers, 12, 15
 power lines, 47
 power supply, 41, 47
 24 VDC, 42
 24-VDC, 41
 present position
 setting for TEACH, 153
 when using TEACH, 152
 Programming Console
 programming examples, 192, 194
 reading error/alarm codes from, 176, 177
 three-channel change operation, 50
 used for teaching, 156
 writing data via the, 50–65
 programming examples, 189
 proximity speed number, setting for ORIGIN SEARCH, 69
 pulse frequency, computation of, 14
 pulse generators, 12
 pulse output, prohibited, 173
 pulse trains, 6, 12, 13
 counting pulses, 181
 detection of abnormalities, 181
 measuring frequency, 181

R–S

READ ERROR. *See* commands
 RELEASE PROHIBIT. *See* commands
 RESET ORIGIN. *See* commands
 resistors, built-in, 40, 41
 restart bits, 50, 51
 AR area, 180
 rotary encoders, 11, 12, 15
 search patterns, 200
 semiclosed-loop systems, 11, 15–16
 servolock, 15
 Servomotor driver, connection, 7
 servomotor drivers, 2, 6, 11, 12, 15, 32
 and origin adjustment, 116
 servomotors, 11, 12, 15
 Settings, interpolation, 86
 signals
 origin, 25
 origin adjustment, 32
 origin proximity, 25, 27, 29, 32
 origin proximity signal, 106, 110, 111
 origin search completed, 46
 origin signal, slit disc used as, 106
 positioning completed, 32, 46
 Z-phase, 27
 single (completion code), 80
 slit disc, used for origin signal, 106
 solenoids, 47
 Special I/O areas, 52
 Special I/O Units
 error list for, 179–187
 maximum number connectable to PC, 8
 maximum number connectable to remote I/O, 8
 speed coefficient, setting for START, 123
 speed coefficient, changing, 219
 speed number, setting for ORIGIN RETURN, 69
 speed units, example of multiplying, 218
 speeds
 calculating data for, 91
 example of setting, 218–231
 Stepping motor
 connection, 6
 with continuous completion, 88
 stepping motor drivers, 2, 6, 12
 stepping motors, 11, 12, 13
 angle of rotation, 13
 STOP
 See also commands
 cautions for using during interpolation, 139
 surge absorbers, 47
 switches
 mode switch, 20, 24–48
 settings, 20–48

T–U

table creation, 95
tachogenerators, 11, 12, 15
target position, setting for START, 85
target speed number, setting for START, 85
TEACH. *See* commands
Transfer buffer, 5
 command bit, 163
TRANSFER DATA. *See* commands
trapezoidal acceleration/deceleration, 94
troubleshooting, from the PC, 179–187
Unit number, conflicts between Units, 20
up/down counters, connections to, 182

V–Z

valid initial positioning action number, setting for START, 123
valid speed coefficient, setting for STOP, 123
wiring, 33–48
 deviation counter reset, 43
 I/O circuit diagrams, 37
 input connection examples, 44–48
 origin input, 45
 origin line driver input, 45
 positioning completed, 46
 origin adjustment command, 43
 output connection examples, 40–48
 precautions, 47–48
 to connectors, 35
 with multi-core cable, 35
zones, 76

Revision History

A manual revision code appears as a suffix to the catalog number on the front cover of the manual.

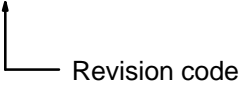
Cat. No. W166-E1-03

The following table outlines the changes made to the manual during each revision. Page numbers refer to the previous version.

Revision code	Date	Revised content
1	July 1989	Original production
2	February 1990	Complete re-organization, and various corrections made.
2A	January 1995	<p>Page 21: Text for operation modes 2 and 3 rewritten.</p> <p>Page 61: "0000" corrected to "0001" for Speeds #1 to #15.</p> <p>Page 86: Last paragraph rewritten.</p> <p>Page 102: Function descriptions for word n+10, bits 13 and 14 have been corrected.</p> <p>Page 104: Function descriptions for word n+15, bits 13 and 14 have been corrected.</p> <p>Pages 183, 185: Note added to the top of the page.</p> <p>Page 186: One page of missing data added.</p> <p>Page 212: Code for word 00 corrected.</p>
2B	October 1996	<p>Page 114: Last sentence on page removed.</p> <p>Page 122: Information in <i>START Activation Time</i> replaced.</p> <p>Page 124: Second sentence of the second paragraph corrected.</p> <p>Page 183: Problem description for alarm codes 1502 to 1515 corrected.</p> <p>Page 184: Problem descriptions for alarm codes 2101 to 2152 and 2301 to 2352 corrected.</p>
03	February 2003	<p>The following changes and additions were made.</p> <p>Page 16: Section of precautions added.</p> <p>Pages 22, 110, 114, 115, : Note added.</p> <p>Page 42: Callouts on right of diagram corrected.</p> <p>Page 59: Note added for "No proximity" in table.</p> <p>Pages 102 and 104: Note added for "Busy flag" in table.</p> <p>Page 222: New appendix A added.</p>

OMRON Corporation

FA Systems Division H.Q.

66 Matsumoto

Mishima-city, Shizuoka 411-8511

Japan

Tel: (81)55-977-9181/Fax: (81)55-977-9045

Regional Headquarters

OMRON EUROPE B.V.

Wegalaan 67-69, NL-2132 JD Hoofddorp

The Netherlands

Tel: (31)2356-81-300/Fax: (31)2356-81-388

OMRON ELECTRONICS LLC

1 East Commerce Drive, Schaumburg, IL 60173

U.S.A.

Tel: (1)847-843-7900/Fax: (1)847-843-8568

OMRON ASIA PACIFIC PTE. LTD.

83 Clemenceau Avenue,

#11-01, UE Square,

Singapore 239920

Tel: (65)6835-3011/Fax: (65)6835-2711

OMRON

Authorized Distributor:

Cat. No. W166-E1-03

C200H-NC211 Position Control Unit

OPERATION MANUAL

OMRON