



Automation

p/n 88-017547-01 B

6K Series Hardware Installation Guide

Effective: November 2005

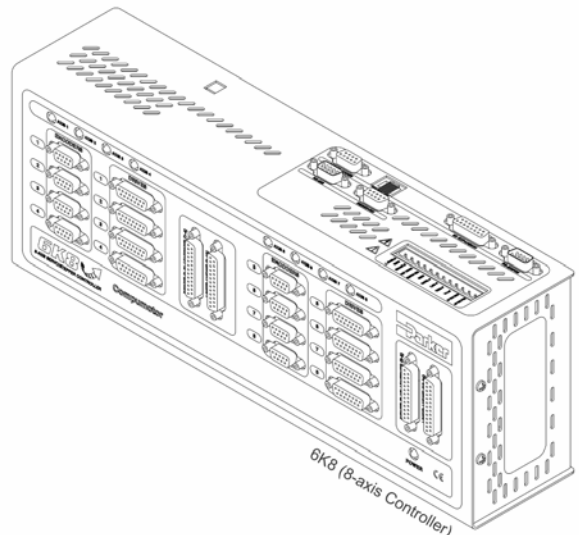
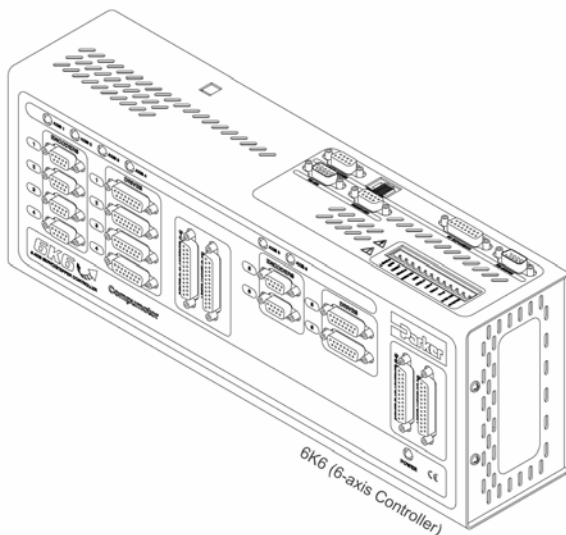
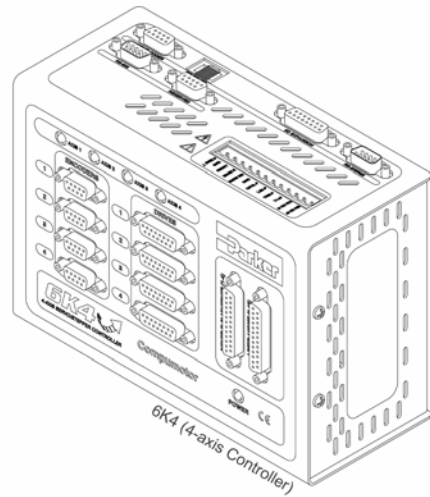
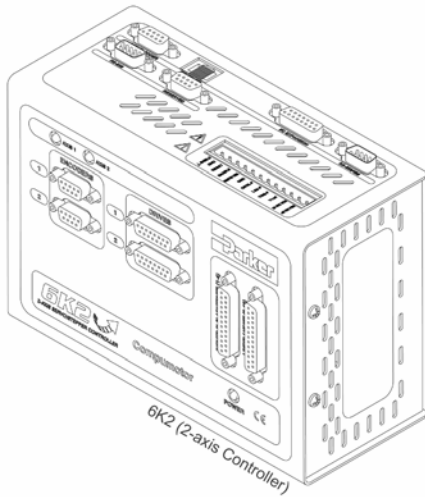

User Information



Warning — 6K Series products are used to control electrical and mechanical components of motion control systems. You should test your motion system for safety under all potential conditions. Failure to do so can result in damage to equipment and/or serious injury to personnel.

6K Series products and the information in this guide are the proprietary property of Parker Hannifin Corporation or its licensors, and may not be copied, disclosed, or used for any purpose not expressly authorized by the owner thereof.

Since Parker Hannifin constantly strives to improve all of its products, we reserve the right to change this guide, and software and hardware mentioned therein, at any time without notice.

In no event will the provider of the equipment be liable for any incidental, consequential, or special damages of any kind or nature whatsoever, including but not limited to lost profits arising from or in any way connected with the use of the equipment or this guide.

© 1998-2005 Parker Hannifin Corporation
All Rights Reserved

Motion Planner and Servo Tuner are trademarks of Parker Hannifin Corporation.

Microsoft and MS-DOS are registered trademarks, and Windows, Visual Basic, and Visual C++ are trademarks of Microsoft Corporation.

Technical Assistance

Contact your local automation technology center (ATC) or distributor.

North America and Asia

Parker Hannifin
5500 Business Park Drive
Rohnert Park, CA 94928
Telephone: (800) 358-9070 or (707) 584-7558
Fax: (707) 584-3793
Email: emn_support@parker.com
Internet: <http://www.parkermotion.com>

Europe (non-German speaking)

Parker Hannifin plc
Electromechanical Automation, Europe
Arena Business Centre
Holy Rood Close
Poole
Dorset, UK
BH17 7BA
Telephone: +44 (0) 1202 606300
Fax: +44 (0) 1202 606301
Email: support.digiplan@parker.com
Internet: <http://www.parker-emd.com>

Germany, Austria, Switzerland

Parker Hannifin
Postfach: 77607-1720
Robert-Bosch-Str. 22
D-77656 Offenburg
Telephone: +49 (0) 781 509-0
Fax: +49 (0) 781 509-176
Email: sales.hauser@parker.com
Internet: <http://www.parker-emd.com>

Italy

Parker Hannifin
20092 Cinisello Balsamo
Milan, Italy via Gounod, 1
Telephone: +39 02 6601 2478
Fax: +39 02 6601 2808
Email: sales.sbc@parker.com
Internet: <http://www.parker-emd.com>



Technical Support E-mail

emn_support@parker.com

Table of Contents

About this Guide	iv
What You Should Know	iv
Related Publications.....	iv
Important User Information.....	v
Change Summary	vi
Revision B Changes	vi
Chapter 1. Installation	1
Before You Begin	2
Recommended Installation Process	2
Electrical Noise Guidelines	2
6K Series Controller Ship Kit.....	3
Optional Accessories	3
6K Series General Specifications	4
RS-485 Setup (Optional)	5
6K Series Dimensions & Mounting	6
Dimensions.....	6
Mounting.....	7
6K Series Electrical Connections	8
Enable Input	9
Drives: Servo ($\pm 10V$) Drives.....	10
Drives: Step & Direction Drives	17
Encoders	23
Limit Inputs	24
Onboard Programmable Inputs and Outputs	25
Communication Interface	28
RP240 Remote Operator Panel	32
Expansion I/O	32
24 VDC Power Input.....	33
Testing the Installation.....	34
What's Next?	35
Chapter 2. Troubleshooting	36
Troubleshooting Basics	37
Technical Support	37
Solutions to Common Problems.....	38
Resolving Serial Communication Problems	42
Product Return Procedure.....	43
Appendix A. VM25 Installation	44
Appendix B. EVM32 Installation	45
EVM32 Description	45
EVM32 Specifications.....	46
EVM32 Dimensions	48
EVM32-II Dimensions	49
Installing the SIM Boards.....	50
Electrical Connections	52
Connecting the 6K controller and EVM32 I/O bricks.....	52
Jumpers.....	53
24 VDC power input	53
Reed Relay Outputs (SIM8-OUT-RLY10).....	54
Digital Inputs (SIM8-IN-EVM32).....	55
Digital Outputs (SIM8-OUT-NPN and SIM8-OUT-PNP)	56
Solid State Relay Outputs (SIM8-OUT-SSR).....	57
High Current Relay Outputs (SIM8-OUT-HCR)	57
Analog Inputs (SIM8-AN-IN)	58

Analog Outputs (SIM8-AN-OUT).....	58
Appendix C. Servo Tuning.....	59
To tune your servo system	59
Tuning-Related Commands	62

About this Guide

This document is designed to help you install and troubleshoot your 6K Series controller. Programming related issues are covered in the *6K Series Programmer's Guide* and the *6K Series Command Reference*.

What You Should Know

To install and troubleshoot the 6K Series controller, you should have a fundamental understanding of:

- Electronics concepts, such as voltage, current, switches.
- Mechanical motion control concepts, such as inertia, torque, velocity, distance, force.
- Ethernet or serial (RS-232 or RS-485) communication, depending on which communication protocol you are using.

Related Publications

- *6K Series Command Reference*, Parker Hannifin Corporation, Electromechanical Automation Division; part number 88-017136-01
- *6K Series Programmer's Guide*, Parker Hannifin Corporation, Electromechanical Automation Division; part number 88-017137-01
- *Ethernet Networking for 6K and Gem6K*, Parker Hannifin Corporation, Electromechanical Automation Division (available on at www.parkermotion.com)
- *COM6srvr for the 6K and Gemini Series*, Parker Hannifin Corporation, Electromechanical Automation Division; part number 88-020680-01
- Current Parker Hannifin *Motion Control Systems* catalog
- Schram, Peter (editor). *The National Electric Code Handbook (Third Edition)*. Quincy, MA: National Fire Protection Association

Important User Information

It is important that motion control equipment is installed and operated in such a way that all applicable safety requirements are met. It is your responsibility as an installer to ensure that you identify the relevant safety standards and comply with them; failure to do so may result in damage to equipment and personal injury. In particular, you should study the contents of this user guide carefully before installing or operating the equipment.

The installation, set up, test, and maintenance procedures given in this guide should only be carried out by competent personnel trained in the installation of electronic equipment. Such personnel should be aware of the potential electrical and mechanical hazards associated with mains-powered motion control equipment—please see the safety warnings below. The individual or group having overall responsibility for this equipment must ensure that operators are adequately trained.

Under no circumstances will the suppliers of the equipment be liable for any incidental, consequential or special damages of any kind whatsoever, including but not limited to lost profits arising from or in any way connected with the use of the equipment or this guide.



Warning — High-performance motion control equipment is capable of producing rapid movement and very high forces. Unexpected motion may occur especially during the development of controller programs. KEEP WELL CLEAR of any machinery driven by stepper or servo motors. Never touch any part of the equipment while it is in operation.

This product is sold as a motion control component to be installed in a complete system using good engineering practice. Care must be taken to ensure that the product is installed and used in a safe manner according to local safety laws and regulations. In particular, the product must be positioned such that no part is accessible while power may be applied.

This and other information from Parker Hannifin Corporation, its subsidiaries, and authorized distributors provides product or system options for further investigation by users having technical expertise. Before you select or use any product or system, it is important that you analyze all aspects of your application and review the information concerning the product in the current product catalog. The user, through its own analysis and testing, is solely responsible for making the final selection of the system and components and assuring that all performance, safety, and warning requirements of the application are met.

If the equipment is used in any manner that does not conform to the instructions given in this user guide, then the protection provided by the equipment may be impaired.

The information in this user guide, including any apparatus, methods, techniques, and concepts described herein, are the proprietary property of Parker Hannifin or its licensors, and may not be copied, disclosed, or used for any purpose not expressly authorized by the owner thereof.

Since Parker Hannifin constantly strives to improve all of its products, we reserve the right to modify equipment and user guides without prior notice. No part of this user guide may be reproduced in any form without the prior consent of Parker Hannifin.

Change Summary

Use the change summary below to view the latest additions, changes, and corrections to the 6K Hardware Installation Guide.

Revision B Changes

Documents 88-017547-01B supersedes documents 88-017547-01A. Changes associated with the 6K Hardware Installation Guide, and document clarifications and corrections are as follows:

Topic	Description
Ship Kit	Corrected Ship Kit part numbers.
Servo Tuning	Updated the servo tuning procedure.
Encoder Schematic	Updated connector schematic.
EVM32 family	Added EVM-II, SIM8-OUT-SSR, and SIM8-OUT-HCR.

CHAPTER ONE

Installation

IN THIS CHAPTER	
Things to consider before you install your 6K controller	2
Product ship kit list.....	3
General specifications table	4
Dimensions and mounting guidelines.....	6
Connecting all electrical components (includes specifications)	8
Testing the installation.....	34
Preparing for what to do next	35

Before You Begin



Warning — The 6K controller is used to control your system's electrical and mechanical components. Therefore, you should test your system for safety under all potential conditions. Failure to do so can result in damage to equipment and/or serious injury to personnel.

Always remove power to the 6K controller before

Connecting electrical devices (e.g. drive, encoder, I/O brick, inputs, outputs, etc.)
Accessing and adjusting internal DIP switches

Recommended Installation Process

1. Check the ship kit to make sure that you have all the items (see page 3).
2. Review the general specifications table (see page 4).
3. (optional) Set internal DIP switches for using the “RS-232/485” connector as an RS-485 serial port (default function is RS-232 and configured for connection to an RP240).
4. Mount the 6K controller (see page 6).
5. Connect all electrical system components (see pages 8-33).
Installation instructions for the EVM32 expansion I/O are provided on page 45.
6. Test the installation (see page 34).
7. Mount the motors and/or couple the loads.
8. Tune any servo axes or axes using the ZETA drive. Use the tuning utility in Motion Planner (see page 59).
9. Program your motion control functions. Programming instructions are provided in the *6K Series Programmer's Guide* and the *6K Series Command Reference*. Use the programming tools provided in Motion Planner (found in your ship kit).

Electrical Noise Guidelines

- Do not route high-voltage wires and low-level signals in the same conduit.
- Ensure that all components are properly grounded.
- Ensure that all wiring is properly shielded.

6K Series Controller Ship Kit

Part Name	Part Number
One of the following 6K products:	
6K2 two-axis controller with ship kit (see 6K-KIT list below).....	6K2
6K2 without ship kit.....	6K2-NK
6K4 four-axis controller with ship kit (see 6K-KIT list below).....	6K4
6K4 without ship kit.....	6K4-NK
6K6 six-axis controller with ship kit (see 6K-KIT list below).....	6K6
6K6 without ship kit.....	6K6-NK
6K8 eight-axis controller with ship kit (see 6K-KIT list below).....	6K8
6K8 without ship kit.....	6K8-NK
Ship kit items (6K-KIT): *	
<i>6K Series Hardware Installation Guide</i>	88-017547-01
<i>6K Series Command Reference</i>	88-017136-01
<i>6K Series Programmer's Guide</i>	88-017137-01
Motion Planner CD-ROM.....	95-017633-01
Ethernet cable (5-foot, RJ-45, cross-over).....	71-017635-01
Peel-and-stick labels for onboard I/O cables.....	87-017636-01

* The panel mounting kit (part number 74-018177-01), which includes two mounting brackets and four screws (6-32 x 1/4), is included with all 6K shipments, independent of the 6K-KIT.

NOTE: If an Item is missing, call the factory (see phone numbers on the inside front cover).

Optional Accessories

Part Name	Part Number
Drive cable to Parker step & direction drives, 10-foot	71-016137-10
Drive cable to $\pm 10V$ drives, 10-foot (no connector at drive end).....	71-017003-10
VM25 25-pin screw-terminal adapter for onboard I/O (with 2-foot cable).....	VM25
60 Watt power supply (DIN rail mountable).....	PS-60W
EVM32 expansion I/O modules. Each module can hold up to four SIM cards for total of up to 128 I/O points. Up to eight EVM32 modules may be connected to your 6K controller.	
EVM32 baseboard, DIN rail mountable (with 2-foot cable)	EVM32-BASE
SIM card with eight digital inputs.....	SIM8-IN
SIM card with eight digital outputs.....	SIM8-OUT-EVM32
SIM card with eight 12-bit analog inputs	SIM8-AN-IN
100-foot cable.....	71-016949-100

6K Series General Specifications

Parameter	Specification
Power (DC input)	24 VDC \pm 10%, 2A max. (current requirements depend on type/amount of I/O used)
Environmental	
Operating temperature.....	32 to 122°F (0 to 50°C)
Storage temperature.....	-22 to 185°F (-30 to 85°C)
Humidity.....	0 to 95% non-condensing
Performance	
Command output	\pm 10V or Step & Direction
Servo update	As fast as 62.5 μ s per axis
Stepping accuracy	\pm 0 counts from preset total
Position range.....	\pm 2,147,483,648 counts
Velocity range	Stepper axes: 1 to 2,000,000 counts/sec; Servo axes: 1 to 12,000,000 counts/sec;
Acceleration range.....	1 to 50,000,000 counts/sec/sec
Communication Interface	
Serial	
Connection	RS-232: 3-wire connections (Rx, Tx and GND) on "RS-232" or "RS-232/485" connectors. The "RS-232/485" connector's default configuration is for RS-232 and set for use with an RP240 (see page 32). RS-485: 2- and 4-wire connections to "RS-232/485" connector. Requires DIP switch changes (see page 5).
Maximum units in daisy chain	99 (use ADDR command to set individual addresses for each unit).
Communication parameters	8 data bits; No parity; Baud: 9600 (set with BAUD command; range: 1200-38400).
Ethernet	10Base-T (10Mbps twisted pair); TCP/IP protocol. RJ-45 connector. Default IP address is 192.168.10.30 (use NTADDR on RS-232 port to change address).
Onboard Inputs	
Encoder inputs.....	Differential comparator accepts two-phase quadrature incremental encoders with differential or single-ended outputs. To use single-ended encoders, jumper pin 8 to pin 9 (not available on Master Encoder connector). The "Master Encoder" connector may not be used for servo feedback or stepper stall detect. Maximum voltage = 5VDC. Switching levels (TTL): Low \leq 0.4V, High \geq 2.4V. Maximum frequency = 12.0 MHz post quadrature.
Limit inputs ("LIMITS/HOME" connectors).....	Voltage range = 0-24 VDC. Factory default is sourcing current, voltage reference is 24 VDC*. To make all limit inputs sink current, connect the "LIM-P" terminal to the "GND" terminal (see connector on top of 6K chassis).
Trigger inputs ("TRIGGERS/OUTPUTS" connectors)..	Voltage range = 0-24 VDC. Factory default is sourcing current, voltage reference is 24 VDC*. To make all trigger inputs sink current, connect the "TRIG-P" terminal to the "GND" terminal (see connector on top of 6K chassis).
Master trigger input ("MASTER TRIG")	(same specification as the rest of the trigger inputs)
Drive Fault input (pin 5 on "DRIVE" connectors) ...	Voltage range = 0-24 VDC. Factory default is sourcing current, voltage reference is 24 VDC*. To make all drive fault inputs sink current, connect the "CNTRL-P" terminal to the "GND" terminal (see connector on top of 6K chassis).
"ENABLE" input	Voltage range = 0-24 VDC. Voltage reference is 24 VDC*. Internal 6.8 K Ω pull-up to 24 VDC. If this input is opened, motion is killed and the program in progress is terminated. If ENABLE is not grounded when motion is commanded, motion will not occur, and the error message "WARNING: ENABLE INPUT ACTIVE" will be displayed to the terminal emulator. (see connector on top of 6K chassis).
Onboard Outputs	
Digital outputs ("TRIGGERS/OUTPUTS" connectors).	Open-collector outputs; will sink up to 300 mA.
+5VDC output (pin 1 on "ENCODER").....	Internally supplied +5VDC. Provides up to 250 mA per encoder.
Servo drive command out (pin 3 on "DRIVE").....	Command signal output to the drive. \pm 10VDC analog output. 12-bit DAC. Load should be $>$ 2 K Ω impedance.
Servo drive shutdown (pins 7 & OUT DIODE) ⁸ on "DRIVE")	Shutdown relay output. Max rating: 175VDC, 0.25A, 3W.
Step, Direction, Shutdown (pins 1,2,11 on "DRIVE")	Differential line drive output. Signal high $>$ 3.5VDC @ +30 mA, signal low $<$ 1.0VDC @ -30 mA. +output for each driver is active high, -output is active low. Step pulse width is 0.3-20 μ s (depending on PULSE command — default is 0.5 μ s).
Flyback diode output ("OUT DIODE")	Connected to 24 VDC power with external jumper — allows you to use internal flyback diode for onboard outputs that are driving inductive loads. DISCONNECT the jumper if the onboard outputs are not driving inductive loads.

* The voltage reference (VINref) is +24 VDC, unless you connect an external 5-24 VDC supply to the "VINref" terminal (see connector on top of 6K chassis). Switching levels: Low \leq 1/3 VINref, High \geq 2/3 VINref.

RS-485 Setup (Optional)

READ THIS FIRST— The “RS-232/485” connector (also referred to as “COM2”) is factory-configured for RS-232 communication; this makes it compatible with an RP240 remote operator panel. If you are not using RS-485 communication, skip this section and proceed to Mounting.



Caution — Remove power before removing the 6K controller’s enclosure.

While handling the 6k controller’s printed circuit assemblies, be sure to observe proper grounding techniques to prevent electrostatic discharge (ESD).

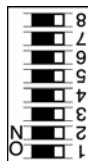
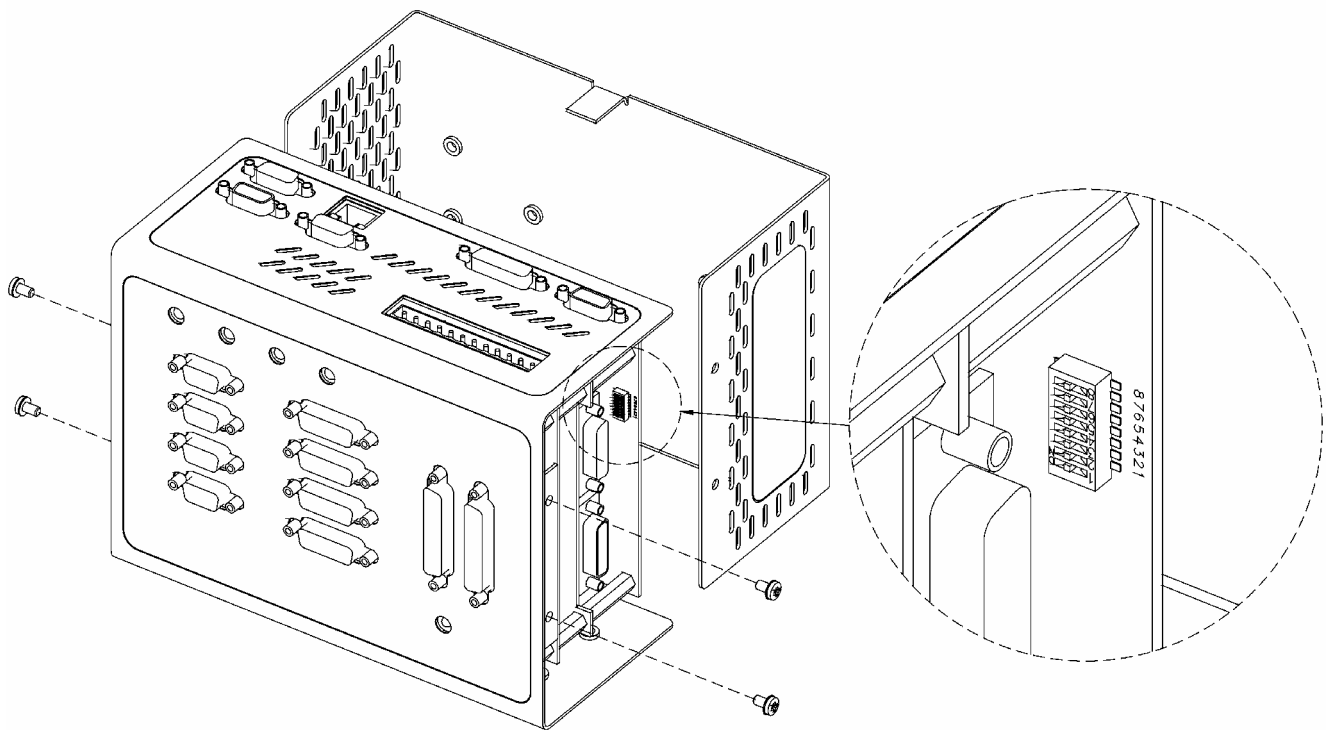

DIP Switch		RS-485 2-Wire	RS-485 4-Wire	RS-232
8	2-wire RS-485	ON	OFF	OFF
7	4-wire RS-485	OFF	ON	OFF
6	Reserved	OFF	OFF	OFF
5	Enable RS-485	ON	ON	OFF
4	120Ω Rx termination resistor	ON *	ON	OFF
3	120Ω Tx termination resistor	ON *	ON	OFF
2	681Ω Tx+ bias resistor	ON	ON	OFF
1	681Ω Tx- bias resistor	ON	ON	OFF

* For 2-wire RS-485, use switch #3 or switch #4 for 120Ω termination (not both).

6K Series Dimensions & Mounting

Dimensions

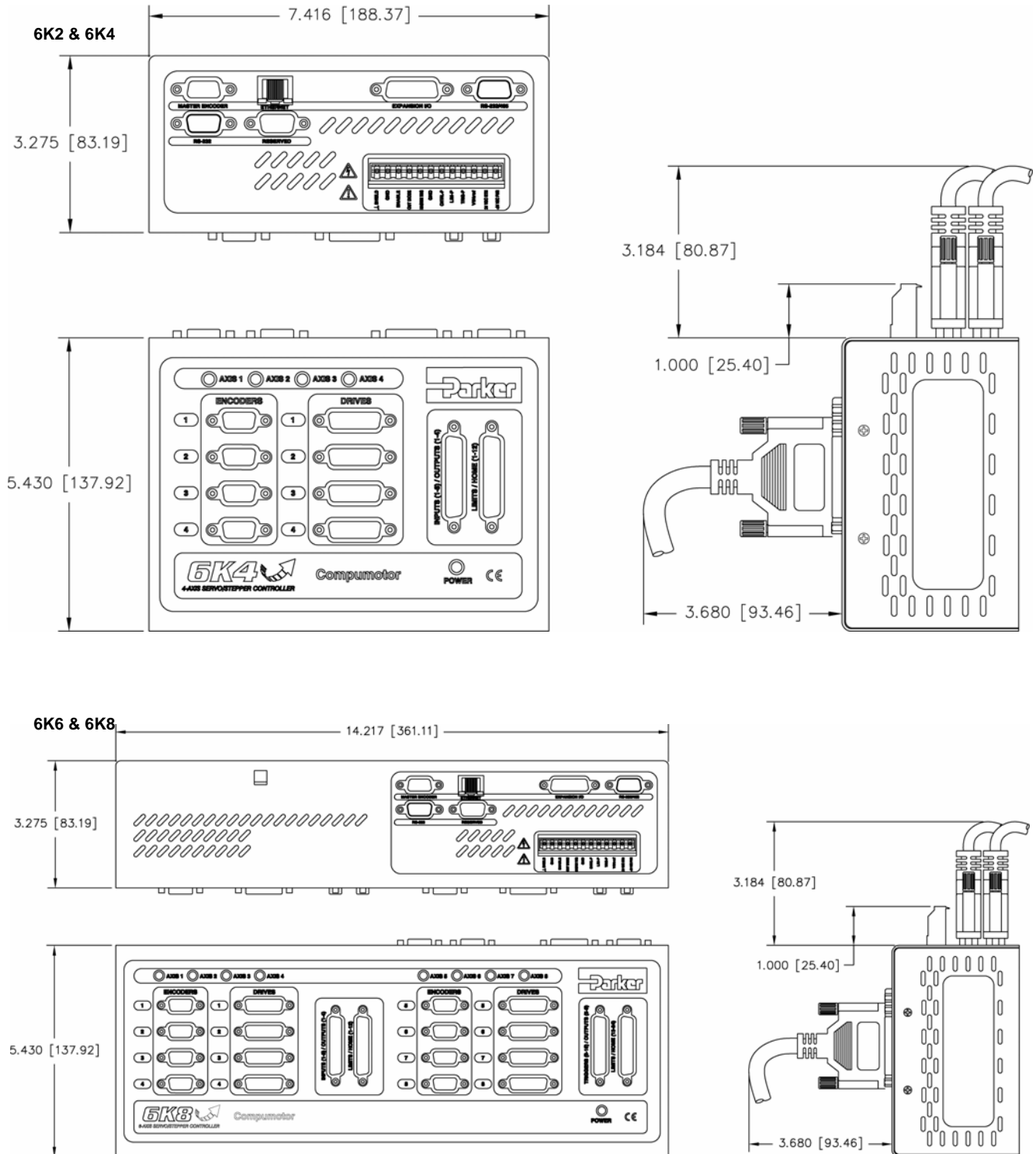

Mounting

Environmental Considerations

Temperature—Operate the 6K in ambient temperatures between 32°F (0°C) and 122°F (50°C). Provide a minimum of 4 inches (100.6 mm) of unrestricted air-flow space around the 6K chassis. Fan cooling may be necessary if adequate air flow is not provided.

Humidity—Keep below 95%, non-condensing.

Airborne Contaminants, Liquids—Particulate contaminants, especially electrically conductive material, such as metal shavings and grinding dust, can damage the 6K. Do not allow liquids or fluids to come in contact with the 6K or its cables.

Mounting Option — DIN Rail

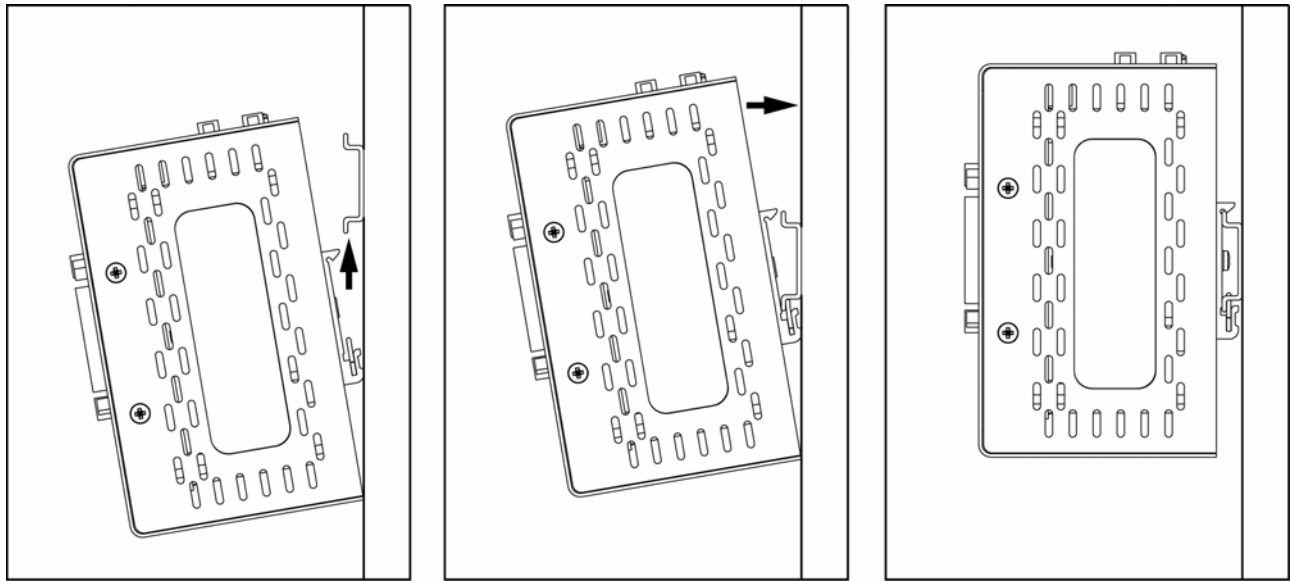

Mounting Option — Brackets (*brackets provided in ship kit*)

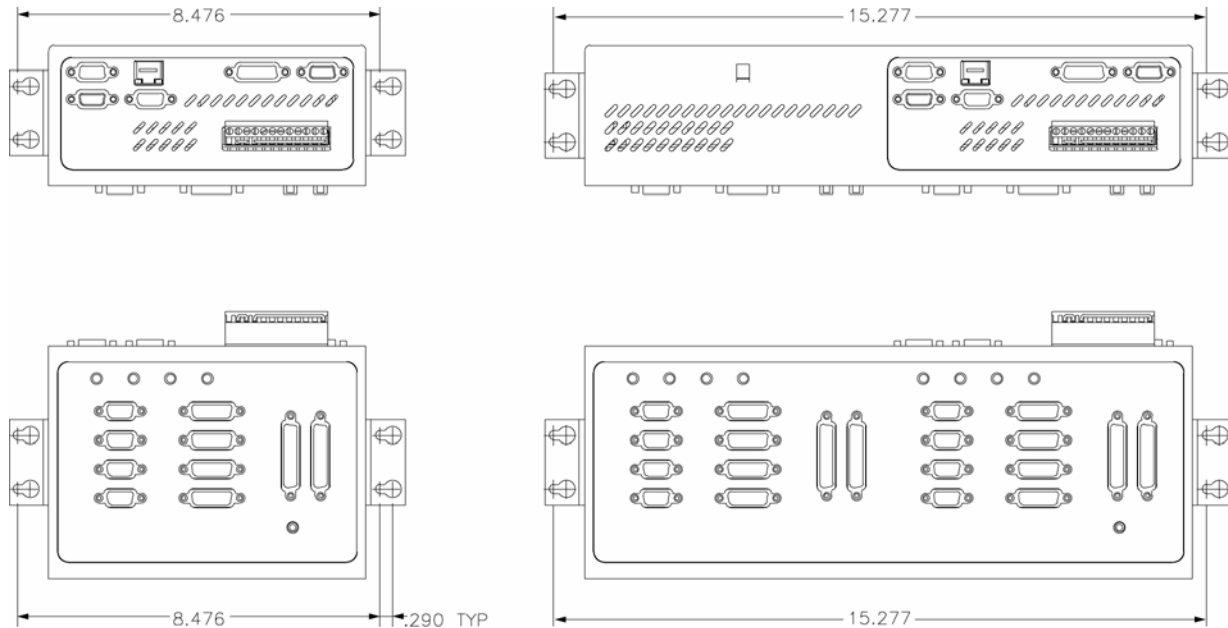

6K Series Electrical Connections

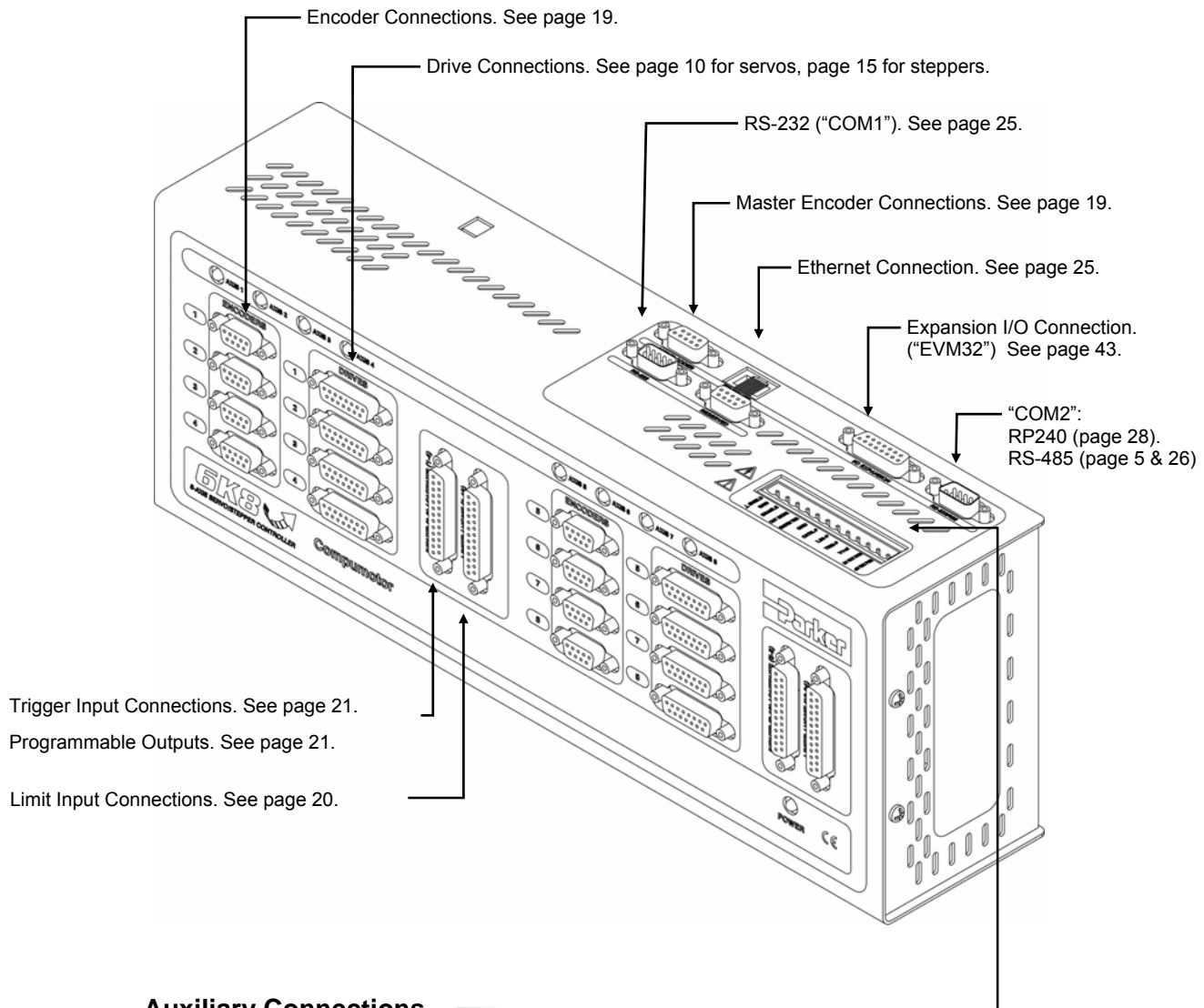

Auxiliary Connections

- +24 VDC PWR +24 VDC power input. See page 29.
- 24 VDC RTN..... 24 VDC power return. See page 29.
- VINref Voltage reference for trigger, limit, drive fault, and enable inputs (default is 24 VDC; if 24 VDC is desired, it is not necessary to connect an external power source to the VINref terminal).
Switching: $\leq 1/3$ VINref = Low; $\geq 2/3$ VINref = High.
- TRIG-P * Pull-up for trigger inputs. No connection necessary for pull-up to 24 VDC. See page 21.
- LIM-P * Pull-up for limit inputs. No connection necessary for pull-up to 24 VDC. See page 20.
- CNTRL-P * Pull-up for drive fault inputs. No connection necessary for pull-up to 24 VDC. See page 10 and 15.
- GND..... Isolated logic ground.
- MASTER TRIG Master Trigger Input. See page 10.
- OUT DIODE..... The 6K is shipped from the factory with this pin connected to 24 VDC power with an external jumper; this uses the internal flyback diode for onboard outputs that are driving inductive loads. DISCONNECT the jumper if the onboard outputs are not driving inductive loads.
- ENABLE Enable Input (**must be connected to GND to allow motion**). See page 9.
- GND..... Isolated logic ground.
- SHIELD..... Internally connected to chassis earth ground.

* The only reason to use the pull-up terminals is to change the respective inputs from sourcing VINref (factory default) to sinking. If sourcing inputs is appropriate for your application, then leave the pull-ups not connected. Note that the factory default is for the inputs to source 24 VDC; if sourcing other than 24 VDC is desired, connect the other voltage to the VINref terminal (e.g., to source 12VDC, connect a user-supplied 12VDC supply to the VINref terminal).

Enable Input

The 6K controller is shipped from the factory with the ENABLE input jumpered to ground, thus allowing motion "out of the box" for bench-testing purposes. Use the diagram below as a guide for connecting the ENABLE input according to your application's needs.

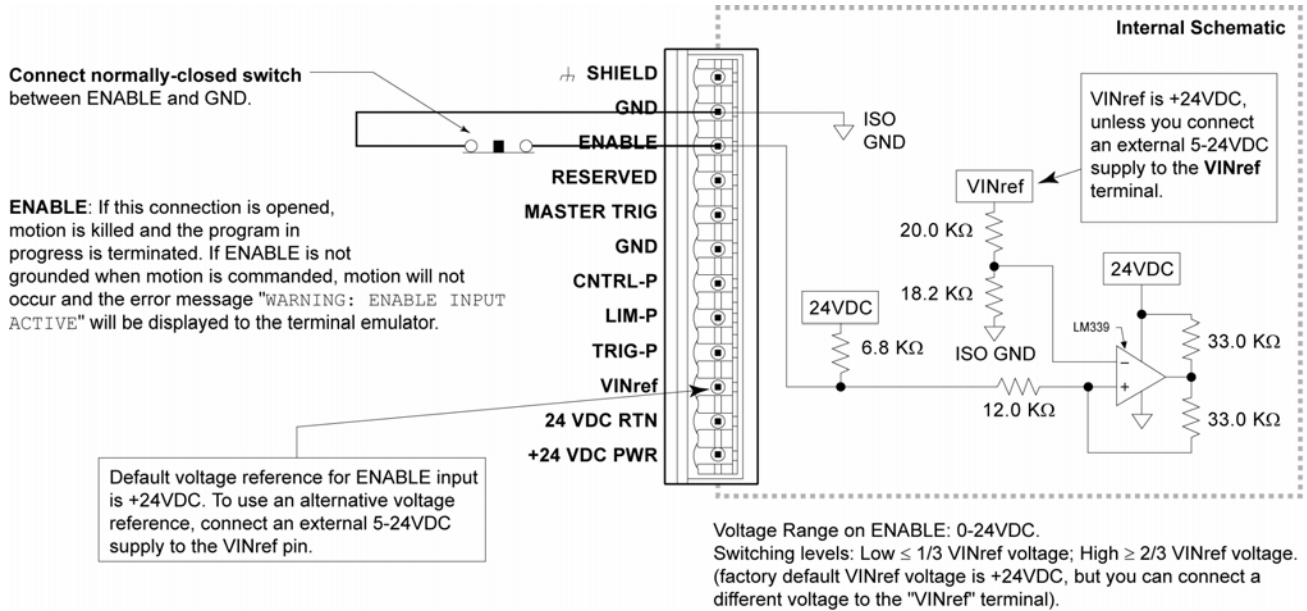
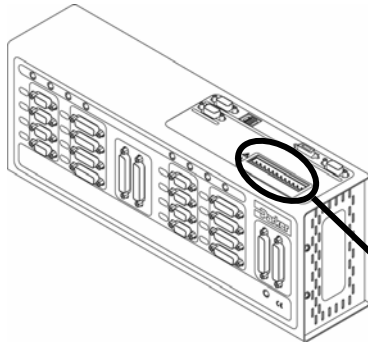

Drives: Servo ($\pm 10V$) Drives

("DRIVES" connectors)

Internal Schematics

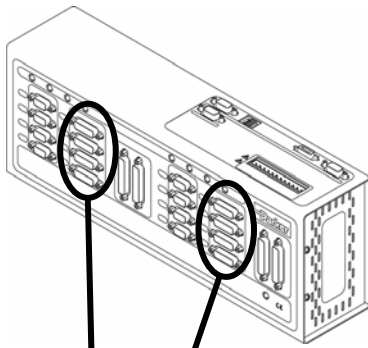

DRIVE Connector

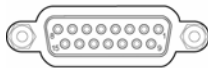

Drive Cable:

Maximum recommended length is 15 feet (4.56 m).
Use 22 AWG wire.

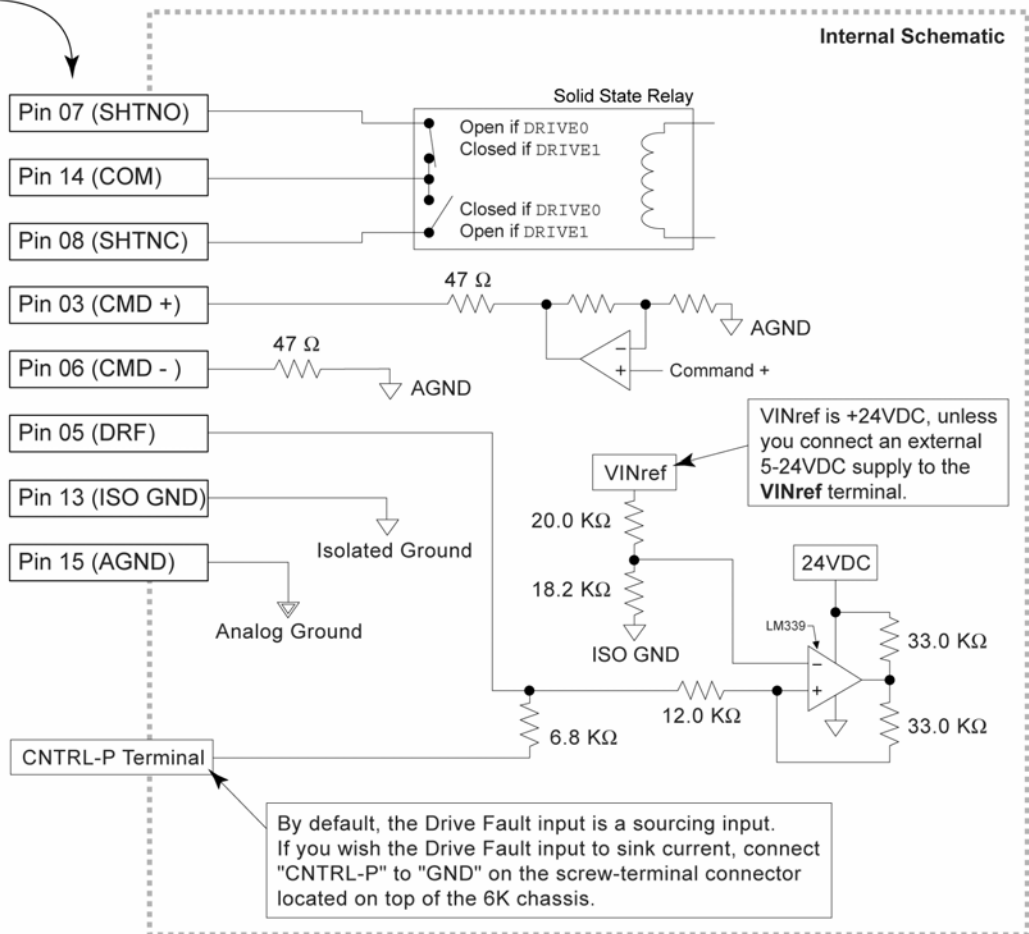

Pin Outs & Specifications — Servo Drives Only (15-Pin “Drive” Connectors)

Pin * Name	In/Out	71-017003-10 Cable Colors ***	Description	
3	CMD +	OUT	Black	Command signal output to the drive. $\pm 10\text{VDC}$ analog output. 12-bit DAC. Load should be $>2\text{k}\Omega$ impedance.
5	DFT	IN	Green	Drive fault input. Set active level with the <code>DRFLVL</code> command (default is active low). The drive fault input will not be recognized until you send a <code>DRFEN1</code> command (enables the input) to the axis. Voltage range for the DFT input is 0-24V. Switching levels: Low $\leq 1/3$ VINref voltage, High $\geq 2/3$ VINref voltage (factory default VINref voltage is +24 VDC, but you can connect a different voltage to the VINref terminal**). To make DFT a sinking input, connect the CNTRL-P terminal** to the GND terminal**.
6	CMD –	IN	Red	Command signal return.
7	SHTNO	OUT	Brown	Shutdown relay output to drives that require an open contact to disable the drive. The shutdown relay is active (disabling the drive) when no power is applied to the 6K. When the 6K is powered up, the shutdown relay remains active until you issue the <code>DRIVE1</code> command to the axis. Max. rating: 175 VDC, 0.25A, 3W. Shutdown active (<code>DRIVE0</code>): this output is disconnected from COM. Shutdown inactive (<code>DRIVE1</code>): this output is internally connected to COM. (see schematic above)
8	SHTNC	OUT	Gray	Shutdown relay output to drives that require a closed contact to disable the drive. The shutdown relay is active (disabling the drive) when no power is applied to the 6K. When the 6K is powered up, the shutdown relay remains active until you issue the <code>DRIVE1</code> command to the axis. Max. rating: 175 VDC, 0.25A, 3W. Shutdown active (<code>DRIVE0</code>): this output is internally connected to COM. Shutdown inactive (<code>DRIVE1</code>): this output is disconnected from COM. (See schematic above)
13	ISO GND	----	White	Isolated logic ground.
14	COM	----	Yellow	Signal common for shutdown. Not connected to any ground or other COM.
15	AGND	----	Blue	Analog ground.

* Pin 1, 2, 4, and 9-12 are reserved for connection to a step & direction drive (see page 17).

** The VINref, CNTRL-P, and GND terminals are located on the screw-terminal connector on top of the 6K chassis.

*** The servo drive cable (p/n 71-017003-10) is a 10-foot cable with no connector on the drive end of the cable. It is sold as an accessory.

CONNECTIONS TO THE APEX SERIES DRIVE

APEX Drive Connections		6K Connections		
Signal Name		Signal Name	Connector	Pin
Enable In	↔	SHTNO	Drive	7
Fault Out	↔	DFT	Drive	5
GND	↔	AGND	Drive	15
		COM	Drive	14
Command +	↔	CMD +	Drive	3
Command –	↔	CMD –	Drive	6
CHA +	↔	A +	Encoder	2
CHA –	↔	A –	Encoder	3
CHB +	↔	B +	Encoder	4
CHB –	↔	B –	Encoder	5
CHZ +	↔	Z +	Encoder	6
CHZ –	↔	Z –	Encoder	7
GND	↔	GND	Encoder	9

← Jumper AGND to COM.

CONNECTIONS TO THE ARIES SERIES DRIVE

Aries Drive Connections				6K Connections		
Signal Name	Connector	Pin		Signal Name	Connector	Pin
GND	Drive I/O	2	↔	GND	Encoder	9
Enc out A+	Drive I/O	3	↔	A+	Encoder	2
Enc out A-	Drive I/O	4	↔	A-	Encoder	3
Enc out B+	Drive I/O	5	↔	B+	Encoder	4
Enc out B-	Drive I/O	6	↔	B-	Encoder	5
Enc out Z+	Drive I/O	7	↔	Z+	Encoder	6
Enc out Z-	Drive I/O	8	↔	Z-	Encoder	7
ENABLE+	Drive I/O	1	↔	SHUTDOWN-	Drive	12
FAULT+	Drive I/O	9	↔	DRF	Drive	5
AIN+	Drive I/O	14	↔	CMD+	Drive	3
AIN-	Drive I/O	15	↔	CMD-	Drive	6
FAULT-	Drive I/O	16	↔	GND	Drive	13
GND	Drive I/O	17	↔	GND	Drive	13
ENABLE-	Drive I/O	21	↔	SHUTDOWN+	Drive	11

CONNECTIONS TO THE BD-E DRIVE

BD-E Drive Connections				6K Connections			
Signal Name	Connector	Pin		Signal Name	Connector	Pin	
V2	User I/O	1	↔	CMD -	Drive	6	
V1	User I/O	2	↔	CMD +	Drive	3	
GND	User I/O	4	↔	GND	Encoder	9	← Jumper SHTNC to ground (GND).
RST	User I/O	5	↔	COM	Drive	14	
+15V	User I/O	6	↔	SHTNO	Drive	7	
				SHTNC	Drive	8	
FT	User I/O	9	↔	DFT	Drive	5	
AOP	User I/O	10	↔	A +	Encoder	2	
AOP	User I/O	11	↔	A -	Encoder	3	
BOP	User I/O	12	↔	B +	Encoder	4	
BOP	User I/O	13	↔	B -	Encoder	5	
ZOP	User I/O	14	↔	Z +	Encoder	6	
ZOP	User I/O	15	↔	Z -	Encoder	7	

NOTE: These connections will work only if the BD-E's jumper LK2 is set to position B (this is not the factory default setting).

CONNECTIONS TO THE COMPAX3 DRIVE

Compax3 Drive Connections			6K Connections			
Signal Name	Connector	Pin		Signal Name	Connector	Pin
Analog input +	x11	9	↔	CMD+	Drive	3
Analog input -	x11	11	↔	CMD-	Drive	6
Output 0	x12	2	↔	DFT	Drive	5
GND 24V	x12	15	↔	GND	Drive	13
Input 0	x12	6	↔	COM	Drive	14
Input 1	x12	7	↔	SHTNO	Drive	7
Input 2	x12	8				
24 V+ Out	x12	1				
24V In for Outputs	x12	11				
A	x11	7	↔	A+	Encoder	2
A/	x11	6	↔	A-	Encoder	3
B	x11	8	↔	B+	Encoder	4
B/	x11	12	↔	B-	Encoder	5
N	x11	14	↔	Z+	Encoder	6
N/	x11	13	↔	Z-	Encoder	7
GND	x11	15	↔	GND	Encoder	9

Jumper pins 6 & 8.

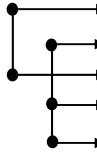

Jumper pins 1, 7, & 11.

CONNECTIONS TO THE DYNASERV DRIVE

Dynaserv Drive Connections			6K Connections			
Signal Name	Connector	Pin		Signal Name	Connector	Pin
A +	DN1	13	↔	A +	Encoder	2
V1	DN1	14	↔	A -	Encoder	3
SRVON	DN1	23	↔	SHTNO	Drive	7
VCC	DN1	24	↔	+5V	Encoder	1
B +	DN1	29	↔	B +	Encoder	4
B -	DN1	30	↔	B -	Encoder	5
Z +	DN1	43	↔	Z +	Encoder	6
Z -	DN1	44	↔	Z -	Encoder	7
VIN	DN1	49	↔	CMD +	Drive	3
AGND	DN1	50	↔	AGND	Drive	15
				COM	Drive	14
				GND	Encoder	9



NOTE: The Dynaserv's default setting is for Position Mode (for accepting step and direction command signals). The connections above assume the Dynaserv is reconfigured for Velocity Mode or Torque Mode. Refer to the Dynaserv user guide for additional information.

CONNECTIONS TO THE DYNASERV GE DRIVE

Dynaserv GE Drive Connections			6K Connections			
Signal Name	Connector	Pin		Signal Name	Connector	Pin
ACMD IN+	CN4	35	↔	CMD+	Drive	3
ACMD IN-	CN4	36	↔	CMD-	Drive	6
DRV RDY OUT	CN4	4	↔	DFT	Drive	5
COMP1	CN4	2	↔	GND	Drive	13
COMP1	CN4	2	↔	COM	Drive	14
SERVO ON IN	CN4	20	↔	SHTNO	Drive	7
COMP1	CN4	1	↔	5 VOLTS+	Encoder	1
UA OUT+	CN4	9	↔	A+	Encoder	2
UA OUT-	CN4	10	↔	A-	Encoder	3
DB OUT+	CN4	11	↔	B+	Encoder	4
DB OUT-	CN4	12	↔	B-	Encoder	5
Z OUT+	CN4	13	↔	Z+	Encoder	6
Z OUT-	CN4	14	↔	Z-	Encoder	7
COMP1	CN4	2	↔	GND	Encoder	9

← Jumper pins 13 & 14.

CONNECTIONS TO THE LINEARSERV DRIVE

Linearserv Connections			6K Connections			
Signal Name	Connector	Pin		Signal Name	Connector	Pin
Com +	CN1	1	↔	+5V	Encoder	1
Servo On -	CN1	5	↔	SHTNO	Drive	7
A +	CN1	17	↔	A +	Encoder	2
B +	CN1	19	↔	B +	Encoder	4
Z +	CN1	21	↔	Z +	Encoder	6
Agnd-TQ	CN1	22	↔	CMD -	Drive	6
Vin-TQ	CN1	23	↔	CMD +	Drive	3
Agnd-VEL	CN1	24	↔	CMD -	Drive	6
Vin-VEL	CN1	25	↔	CMD +	Drive	3
Com -	CN1	26	↔	AGND	Drive	15
Ready +	CN1	31	↔	DFT	Drive	5
A -	CN1	41	↔	A -	Encoder	3
B -	CN1	43	↔	B -	Encoder	5
Z -	CN1	45	↔	Z -	Encoder	7
				COM	Drive	14
				GND	Encoder	9

When the Linearserv is in Torque Mode, connect Agnd-TQ to CMD -, and connect Vin-TQ to CMD +.

When the Linearserv is in Velocity Mode, connect Agnd-VEL to CMD -, and connect Vin-VEL to CMD +.

← Jumper COM to ground (GND).

NOTE: The Linearserv's default setting is for Position Mode (for accepting step and direction command signals). The connections above assume the Linearserv is reconfigured for Velocity Mode or Torque Mode. Refer to the Linearserv user guide for additional information.

CONNECTIONS TO THE OEM670T & OEM675T DRIVE

OEM67x Drive Connections			6K Connections		
Signal Name	Pin		Signal Name	Connector	Pin
CMD +	1	↔	CMD +	Drive	3
CMD -	2	↔	CMD -	Drive	6
FAULT	9	↔	DFT	Drive	5
ENABLE	10	↔	SHTNO	Drive	7
GND	11	↔	COM	Drive	14
GND	16	↔	AGND	Drive	15
GND	7	↔	GND	Drive	13

CONNECTIONS TO THE SV DRIVE

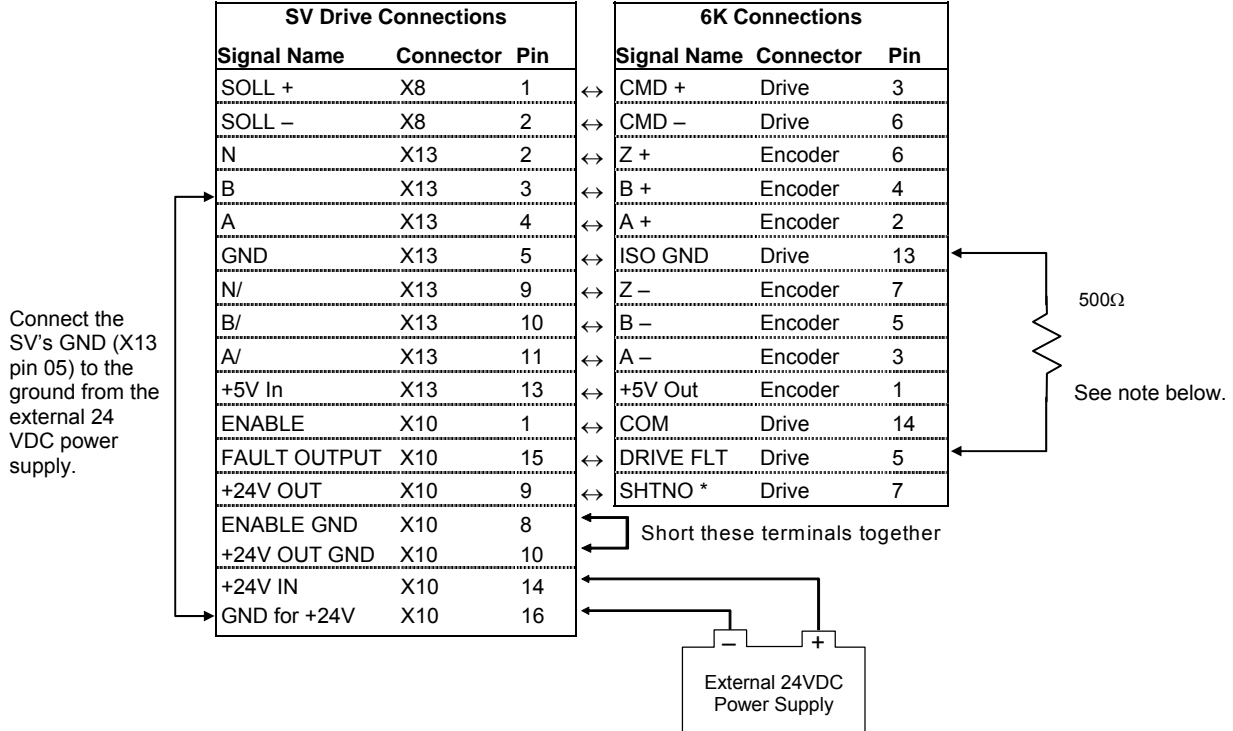

* The SHTNO relay output is active (disabling the drive) when no power is applied to the 6K. When the 6K is powered up, the shutdown relay remains active until you issue a `DRIVE1` command to the axis.

NOTE: Adding the 500Ω resistor assumes the drive fault input is pulled up. (CNTRL-P is internally pulled up to the voltage at the VINref terminal — if no voltage is connected to VINref, CNTRL-P is pulled up internally to 24 VDC.) However, if all axes are SV drives, do not connect the 500Ω resistor; instead, connect the CNTRL-P pin to GND.

CONNECTIONS TO THE TQ10 DRIVE

TQ Drive Connections			6K Connections		
Signal Name	Pin		Signal Name	Connector	Pin
ENABLE IN	1	↔	SHTNO	Drive	7
ENABLE GND	2	↔	COM	Drive	14
FAULT OUT +	3	↔	DFT	Drive	5
FAULT OUT -	4	↔	AGND	Drive	15
COMMAND +	7	↔	CMD +	Drive	3
COMMAND -	8	↔	CMD -	Drive	6
COMMAND SHLD	9	↔	(Cable Shield)	-----	----
GND	10				

Jumper pins 04 and 10.

CONNECTIONS TO THE Vix DRIVE

Vix Drive Connections			6K Connections		
Signal Name	Connector	Pin	Signal Name	Connector	Pin
ANA1+ IN	X4	1	CMD+	Drive	3
ANA1- IN	X4	2	CMD-	Drive	6
			COM	Drive	14
0V	X4	3	GND	Drive	13
ENABLE	X4	11	SHTNO	Drive	7
FAULT OUTPUT	X4	6	DRF	Drive	5
ENC. A+ OUT	X4	14	A+	Encoder	2
ENC. A- OUT	X4	9	A-	Encoder	3
ENC. B+ OUT	X4	15	B+	Encoder	4
ENC. B- OUT	X4	10	B-	Encoder	5
ENC. Z+ OUT	X4	5	Z+	Encoder	6
ENC. Z- OUT	X4	4	Z-	Encoder	7

Jumper COM to ground (GND).

Drives: Step & Direction Drives

("DRIVES" connectors)

INTERNAL SCHEMATICS

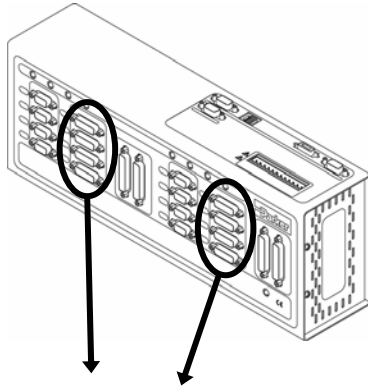

Drive Cable:

Maximum recommended length is 50 feet (15.24 m).
Use 22 AWG wire.

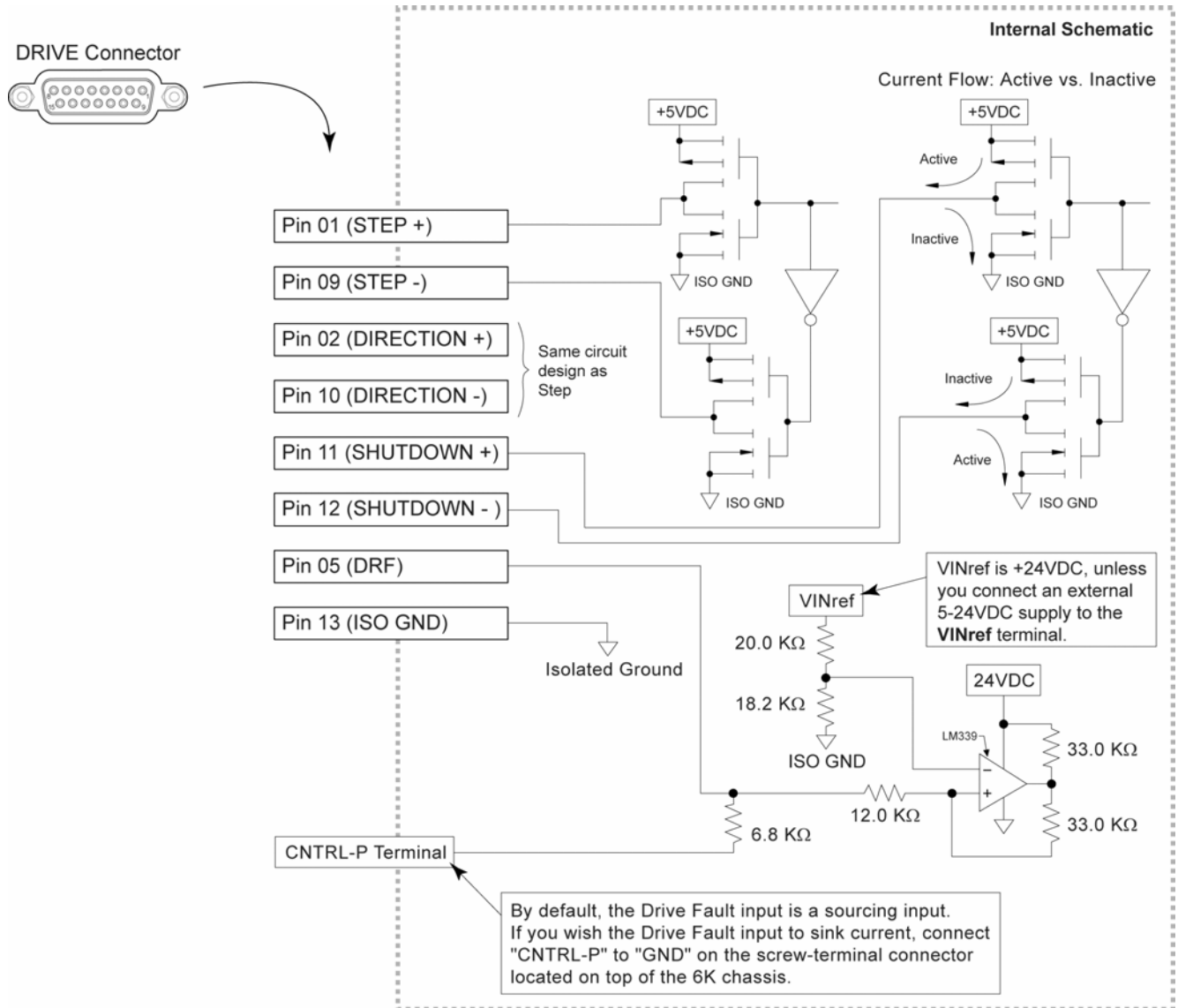

PIN OUTS & SPECIFICATIONS — STEPPER DRIVES ONLY (15-pin “DRIVE” connectors)

Pin *	Name	In/Out	Description
1	Step +	OUT	Differential output. Step (pulse) output to the drive. Step + signal is active high. Signal levels: Low \leq 1.0 VDC @ -30 mA, High \geq 3.5 VDC @ +30 mA.
2	Direction +	OUT	Differential output. High signal on Direction + specifies motion in the positive direction; Low signal on direction + specifies motion in the negative direction. Signal levels: Low \leq 1.0 VDC @ -30 mA, High \geq 3.5 VDC @ +30 mA.
4	Stall	IN	Encoder-less Stall Detection input for use with the GEMINI drive.
5	DFT	IN	Drive fault input. Set active level with the DRFLVL command (default is active low). The drive fault input will not be recognized until you send a DRFEN1 command (enables the input) to the axis. Voltage range for the DFT input is 0-24V. Switching levels: Low \leq 1/3 VINref voltage, High \geq 2/3 VINref voltage (factory default VINref voltage is +24 VDC, but you can connect a different voltage to the VINref terminal**). To make DFT a sinking input, connect the CNTRL-P terminal** to the GND terminal**.
9	Step –	OUT	Differential output. Step (pulse) output to the drive. Step – signal is active low.
10	Direction –	OUT	Differential output. Low signal on Direction – specifies motion in the positive direction; High signal on direction – specifies motion in the negative direction.
11	Shutdown +	OUT	Differential output. This signal is used to turn off current in the motor windings. High signal on Shutdown + indicates the motor winding current should be off. Signal levels: Low \leq 1.0 VDC @ -30 mA, High \geq 3.5 VDC @ +30 mA.
12	Shutdown –	OUT	Differential output. This signal is used to turn off current in the motor windings. Low signal on Shutdown – indicates the motor winding current should be off.
13	ISO GND	----	Isolated logic ground.

* Pin 3-4, 6-8, and 15 are reserved for connection to a \pm 10V analog servo drive (see page 10).

** The VINref, CNTRL-P, and GND terminals are located on the screw-terminal connector on top of the 6K chassis.

CONNECTIONS TO THE ARIES SERIES DRIVE

Aries Drive Connections				6K Connections		
Signal Name	Connector	Pin		Signal Name	Connector	Pin
GND	Drive//O	2	↔	GND	Encoder	9
Enc outA+	Drive//O	3	↔	A+	Encoder	2
Enc outA-	Drive//O	4	↔	A-	Encoder	3
Enc outB+	Drive//O	5	↔	B+	Encoder	4
Enc out B-	Drive//O	6	↔	B-	Encoder	5
Enc out Z+	Drive//O	7	↔	Z+	Encoder	6
Enc out Z-	Drive//O	8	↔	Z-	Encoder	7
ENABLE+	Drive//O	1	↔	SHUTDOWN-	Drive	12
FAULT+	Drive//O	9	↔	DRF	Drive	5
STEP+	Drive//O	10	↔	STEP+	Drive	1
STEP-	Drive//O	11	↔	STEP-	Drive	9
DIRECTION+	Drive//O	12	↔	DIRECTION+	Drive	2
DIRECTION-	Drive//O	13	↔	Direction-	Drive	10
FAULT-	Drive//O	16	↔	GND	Drive	13

CONNECTIONS TO THE COMPAX3 DRIVE

Compax3 Drive Connections			6K Connections		
Signal Name	Connector	Pin	Signal Name	Connector	Pin
Step+ (5V)	x11	7	↔ STEP+	Drive	1
Step- (5V)	x11	6	↔ STEP-	Drive	9
Dir + (5V)	x11	8	DIRECTION-	Drive	10
Dir - (5V)	x11	12	↔ DIRECTION+	Drive	2
Output 0	x12	2	↔ DFT	Drive	5
GND 24 V	x12	15	↔ GND	Drive	13
Input 0	x12	6	↔ COM	Drive	14
Input 1	x12	7	↔ SHTNO	Drive	7
Input 2	x12	8			
24 V+ Out	x12	1			
24V In for Outputs	x12	11			

Jumper pins 6 & 8.

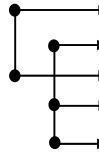

Jumper pins 1, 7, & 11.

CONNECTIONS TO THE DYNASERV DRIVE

Dynaserv Drive Connections			6K Connections		
Signal Name	Connector	Pin	Signal Name	Connector	Pin
Step +	DN1	45	↔ Step +	Drive	1
Step -	DN1	46	↔ Step -	Drive	9
Direction +	DN1	20	↔ Direction +	Drive	2
Direction -	DN1	19	↔ Direction -	Drive	10
Servo On -	DN1	23	↔ Shutdown +	Drive	11
Servo On +	DN1	24	↔ Shutdown -	Drive	12
Servo Ready +	DN1	15	↔ Drive Fault	Drive	5
Servo Ready -	DN1	16	↔ Ground	Drive	13
A +	DN1	13	↔ A +	Encoder	2
A -	DN1	14	↔ A -	Encoder	3
B +	DN1	29	↔ B +	Encoder	4
B -	DN1	30	↔ B -	Encoder	5
Z +	DN1	43	↔ Z +	Encoder	6
Z -	DN1	44	↔ Z -	Encoder	7

NOTE: These connections assume that the Dynaserv is left in its factory default setting for Position Mode (for accepting step and direction command signals). Refer to your Dynaserv user guide for verification.

CONNECTIONS TO THE DYNASERV GE DRIVE

Dynaserv GE Drive Connections			6K Connections			
Signal Name	Connector	Pin		Signal Name	Connector	Pin
ACMD IN+	CN4	35	↔	CMD+	Drive	3
ACMD IN-	CN4	36	↔	CMD-	Drive	6
DRV RDY OUT	CN4	4	↔	DFT	Drive	5
COMP1	CN4	2	↔	GND	Drive	13
COMP1	CN4	2	↔	COM	Drive	14
SERVO ON IN	CN4	20	↔	SHTNO	Drive	7
COMP1	CN4	1	↔	5 VOLTS+	Encoder	1
UA OUT+	CN4	9	↔	A+	Encoder	2
UA OUT-	CN4	10	↔	A-	Encoder	3
DB OUT+	CN4	11	↔	B+	Encoder	4
DB OUT-	CN4	12	↔	B-	Encoder	5
Z OUT+	CN4	13	↔	Z+	Encoder	6
Z OUT-	CN4	14	↔	Z-	Encoder	7
COMP1	CN4	2	↔	GND	Encoder	9

← Jumper pins 13 & 14.

CONNECTIONS TO THE EAC, EDC, OEM750, S, PDS, and ZETA DRIVES

Drive Connections			6K Connections			
Signal Name	Connector	Pin		Signal Name	Connector	Pin
Step +	25-pin	1	↔	Step +	Drive	1
Step -	25-pin	14	↔	Step -	Drive	9
Direction +	25-pin	2	↔	Direction +	Drive	2
Direction -	25-pin	15	↔	Direction -	Drive	10
Shutdown +	25-pin	16	↔	Shutdown +	Drive	11
Shutdown -	25-pin	17	↔	Shutdown -	Drive	12
Fault Output	25-pin	9	↔	Drive Fault	Drive	5
Fault Return	25-pin	21	↔	Ground	Drive	13

- NOTES**
- The PDS drive requires a PULSE command setting of 1.0 (PULSE1.0).
 - Use the 10-foot cable (p/n 71-016137-10) for plug compatibility.

CONNECTIONS TO THE LINEARSERV DRIVE

Linearserv Drive Connections			6K Connections			
Signal Name	Connector	Pin		Signal Name	Connector	Pin
Step +	CN1	15	↔	Step +	Drive	1
Step -	CN1	39	↔	Step -	Drive	9
Direction +	CN1	13	↔	Direction +	Drive	2
Direction -	CN1	37	↔	Direction -	Drive	10
Servo On -	CN1	5	↔	Ground	Drive	13
Servo On +	CN1	1	↔	Shutdown -	Drive	12
Servo Ready +	CN1	31	↔	Drive Fault	Drive	5
Servo Ready -	CN1	26	↔	Ground	Drive	13
A +	CN1	17	↔	A +	Encoder	2
A -	CN1	41	↔	A -	Encoder	3
B +	CN1	19	↔	B +	Encoder	4
B -	CN1	43	↔	B -	Encoder	5
Z +	CN1	21	↔	Z +	Encoder	6
Z -	CN1	45	↔	Z -	Encoder	7

NOTE: These connections assume that the Linearserv is left in its factory default setting for Position Mode (for accepting step and direction command signals). Refer to your Linearserv user guide for verification.

CONNECTIONS TO THE OEM670SD DRIVE

OEM670SD Connections			6K Connections			
Signal Name	Connector	Pin		Signal Name	Connector	Pin
Step +	25-pin	3	↔	Step +	Drive	1
Step -	25-pin	14	↔	Step -	Drive	9
Direction +	25-pin	4	↔	Direction +	Drive	2
Direction -	25-pin	15	↔	Direction -	Drive	10
Shutdown +	25-pin	12	↔	Shutdown +	Drive	11
Shutdown -	25-pin	13	↔	Shutdown -	Drive	12
ISO Fault +	25-pin	22	↔	Drive Fault	Drive	5
Fault Return	25-pin	23	↔	Ground	Drive	13

CONNECTIONS TO THE PKH130M DRIVE

PKH130 Drive Connections		6K Connections			
Signal Name	Pin		Signal Name	Connector	Pin
Clock	6	↔	Step -	Drive	9
Direction	5	↔	Direction +	Drive	2
Fault	2	↔	Drive Fault	Drive	5
Reset	7	↔	Shutdown -	Drive	12
0V	8	↔	Ground	Drive	13

NOTE: The PKH130M drive requires a PULSE setting of PULSE8 . 0.

CONNECTIONS TO THE VIX DRIVE

Vix Drive Connections				6K Connections		
Signal Name	Connector	Pin		Signal Name	Connector	Pin
0V	X4	3	↔	COM	Drive	14
ENABLE	X4	11	↔	GND	Drive	13
ENC. A+ IN	X4	12	↔	SHTNO	Drive	7
ENC. A- IN	X4	7	↔	STEP+	Drive	1
ENC. B- IN	X4	8	↔	STEP-	Drive	9
ENC. B+ IN	X4	13	↔	DIRECTION-	Drive	10
FAULT OUTPUT	X4	6	↔	DIRECTION+	Drive	2
ENC. A+ OUT	X4	14	↔	DRF	Drive	5
ENC. A- OUT	X4	9	↔	A+	Encoder	2
ENC. B+ OUT	X4	15	↔	A-	Encoder	3
ENC. B- OUT	X4	10	↔	B+	Encoder	4
ENC. Z+ OUT	X4	5	↔	B-	Encoder	5

Encoders ("ENCODERS" and "MASTER ENCODER" connectors)

ENCODER INPUTS: Differential comparator accepts two-phase quadrature incremental encoders with differential (recommended) or single-ended outputs. Max. frequency is 12.0 MHz post quadrature. TTL-compatible voltage levels: Low $\leq 0.4V$, High $\geq 2.4V$. Maximum input voltage is 5 VDC.

MASTER ENCODER: The master encoder is used for Following, and not for servo feedback or stepper stall detect. The pin outs are the same as the other encoders, except that pin 8 is ISO GND (can't use a single-ended encoder).

NOTE:
When connecting a -HJ single-ended encoder to the 6K, be sure to connect the encoder's white lead (channel A+) to pin #2 (A+). The current Installation Guide incorrectly shows the white lead connected to

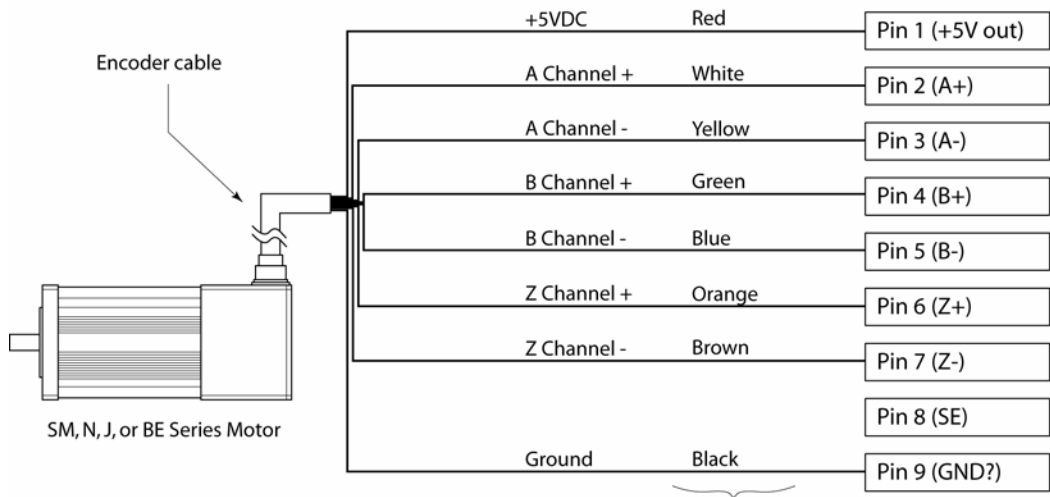
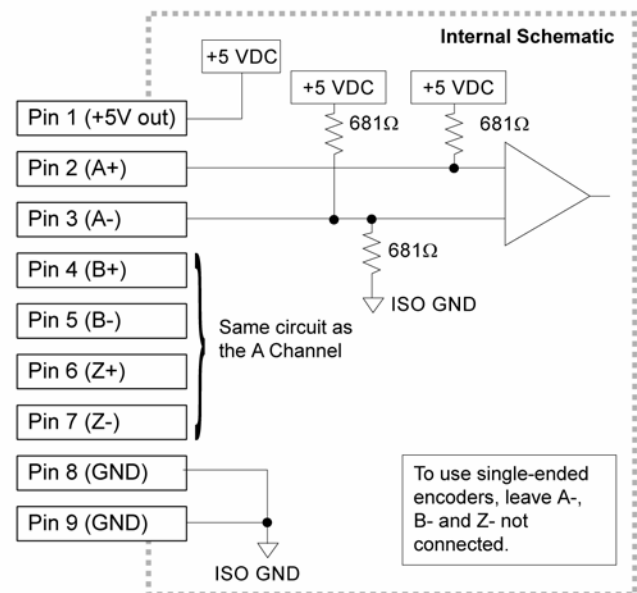
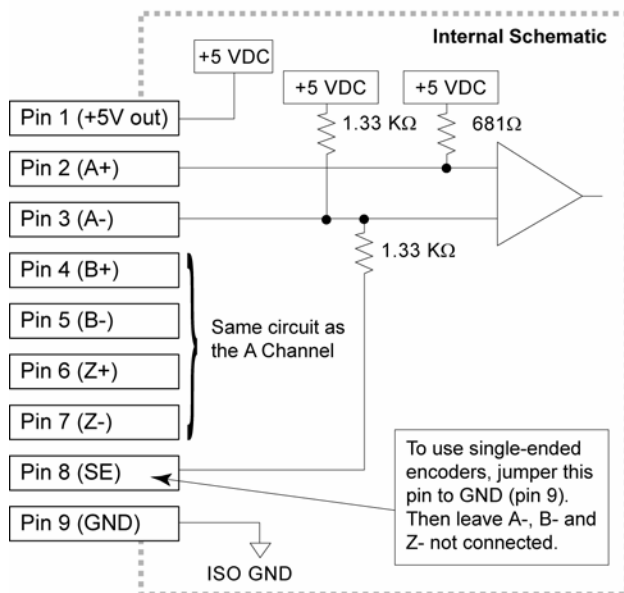
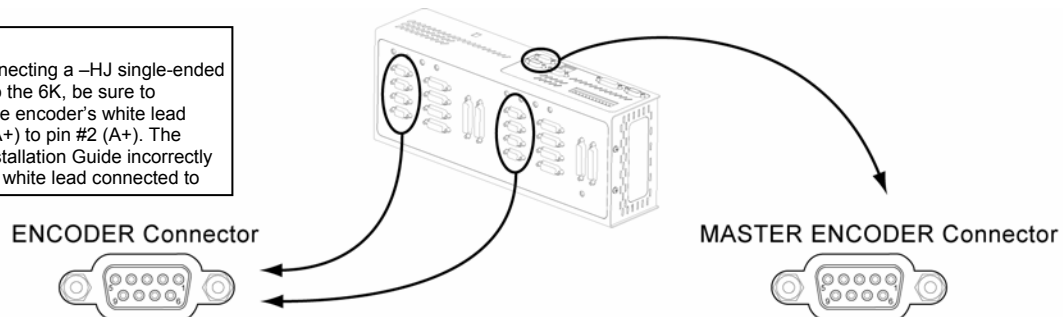

Wire colors for SM, N and J encoder cables

Limit Inputs ("LIMITS/HOME" connectors)

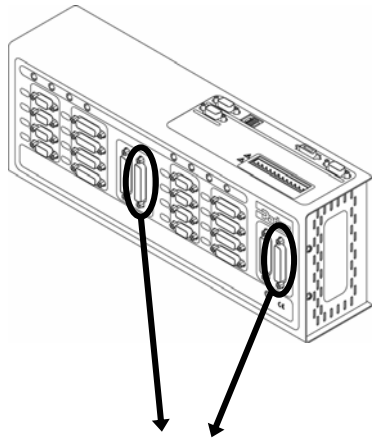

LIMITS/HOME Connector

Connections shown for one axis

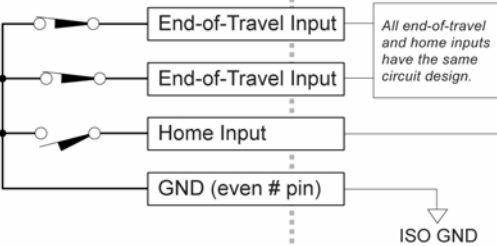

NOTES

- Motion will not occur on an axis until you do one of the following:
 - Install end-of-travel limit switches
 - Disable end-of-travel limits with the `LHØ` command (only if load not coupled)
 - Change the active level of the limits with the `LIMLVL` command.
- End-of-travel input functionality: Mount each switch such that the load forces it to open before it reaches the physical travel limit (leave enough room for the load to stop). When the load opens the switch, the axis stops at the `LHAD` deceleration. The motor will not be able to move in that same direction until you execute a move in the opposite direction and clear the limit by closing the switch.
- Home input functionality: After initiating a homing move with the `HOM` command, the 6K waits for the home input switch to close, indicating the load has reached the desired "home" reference position.
- Refer to the Basic Operation Setup chapter in the *6K Series Programmer's Guide* for in-depth discussions about using end-of-travel limits and homing.
- See page 41 for connections to the "VM25" screw-terminal converter (sold separately).

Internal Schematic

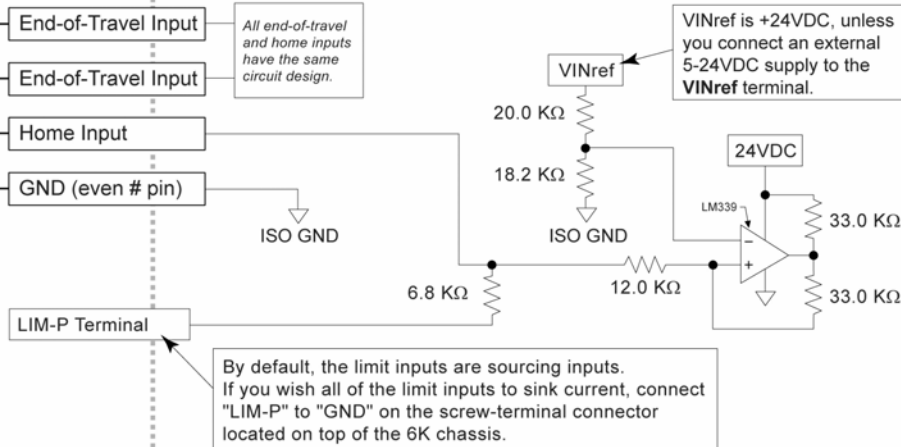

For easy screw-terminal connections, use the "VM25" screw-terminal converter (sold separately, includes 2-foot cable). Connection instructions are provided on page 41.

PIN OUTS & SPECIFICATIONS

Pin #	In/Out	Axes 1-4	Axes 5-8	Description (input functions programmed by LIMFNC)	Specification for limit inputs
25	---	---	---	RESERVED	<ul style="list-style-type: none"> • Voltage range is 0-24 VDC. • Switching levels: Low $\leq 1/3$ VINref voltage, High $\geq 2/3$ VINref voltage (factory default VINref voltage is +24 VDC, but you can connect a different voltage to the VINref terminal**). To make all limit inputs sinking inputs, connect the LIM-P terminal** to the GND terminal**. • Status: Check with <code>TLIM</code> or <code>LIM</code>. • Active level is set with the <code>LIMLVL</code> command. Default is active low: end-of-travel limits which require a n.c. switch and home limits which require a n.o. switch.
23	IN	1POS	5POS	Positive direction end-of-travel limit, axis 1 or 5.	
21	IN	1NEG	5NEG	Negative direction end-of-travel limit, axis 1 or 5.	
19	IN	1HOME	5HOME	Home limit, axis 1 or 5.	
17	IN	2POS	6POS	Positive direction end-of-travel limit, axis 2 or 6.	
15	IN	2NEG	6NEG	Negative direction end-of-travel limit, axis 2 or 6.	
13	IN	2HOME	6HOME	Home limit, axis 2 or 6.	
11	IN	3POS*	7POS *	Positive direction end-of-travel limit for axis 3 or 7.	
9	IN	3NEG*	7NEG *	Negative direction end-of-travel limit for axis 3 or 7.	
7	IN	3HOME*	7HOME *	Home limit, or general purpose input for axis 3 or 7.	
5	IN	4POS*	8POS *	Positive direction end-of-travel limit for axis 4 or 8.	
3	IN	4NEG*	8NEG *	Negative direction end-of-travel limit for axis 4 or 8.	
1	IN	4HOME*	8HOME *	Home limit for axis 4 or 8.	

All even number pins are connected to isolated logic ground.

* On 6K2 and 6K6 products, these pins function as general-purpose inputs (function is set with the `LIMFNCI-A` command).

** The VINref, LIM-P, and GND terminals are located on the screw-terminal connector on top of the 6K chassis.

Onboard Programmable Inputs and Outputs

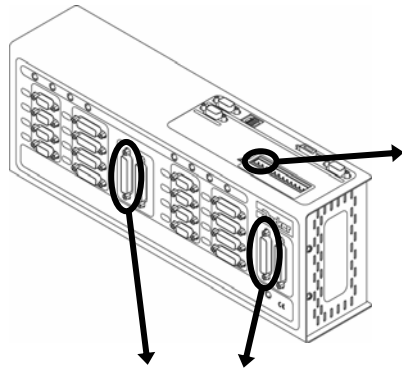

Master Trigger: The “MASTER TRIG” input on this connector has the same circuit design as trigger inputs on the “TRIGGERS/OUTPUTS” connectors.

TRIGGERS/OUTPUTS Connector

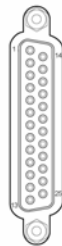

For easy screw-terminal connections, use the “VM25” screw-terminal converter (sold separately, includes 2-foot cable). Connection instructions are provided on page 41.

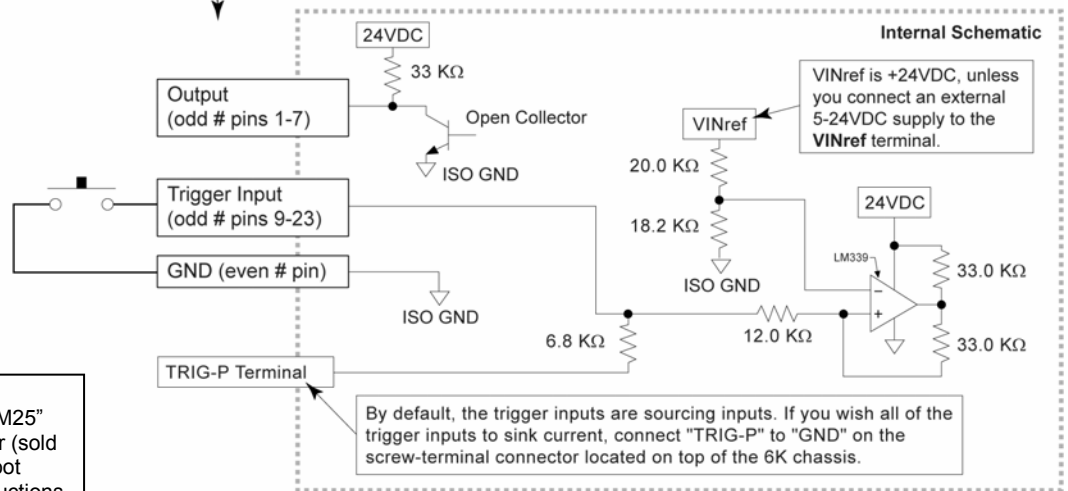

PIN OUTS & SPECIFICATIONS (25-pin “TRIGGERS/OUTPUTS” connectors)

Pin #*	In/Out	Description (axes 1-4)	Description (axes 5-8)	Specs for Trigger Inputs	Specs for GP Outputs
25	----	Reserved	Reserved	<ul style="list-style-type: none"> Voltage range is 0-24 VDC. Trigger input switching levels: Low $\leq 1/3$ VINref voltage, High $\geq 2/3$ VINref voltage (factory default VINref voltage is +24 VDC, but you can connect a different voltage to the VINref terminal**). To make all limit inputs sinking inputs, connect the TRIG-P terminal** to the GND terminal**. Status: Check with TIN or IN. Programmable functions with the INFNC command. Can also be used as a “Trigger Interrupt” input (INFNCi-H) for position capture and registration. Active level is set with the INLVL command. Default is active low (see n.o. switch in diagram above). 	<ul style="list-style-type: none"> Open collector output; will sink up to 300 mA. Status: Check with TOUT or OUT. Programmable functions with the OUTFNC command. Can also be used as an “Output on Position” output (OUTFNCi-H). Active level is set with the OUTLVL command. Default is active low. If the outputs are driving inductive loads, connect the OUT DIODE terminal to 24 VDC.
23	IN	Trigger input 1 (TRIG-1A)	Trigger input 9 (TRIG-5A)		
21	IN	Trigger input 2 (TRIG-1B)	Trigger input 10 (TRIG-5B)		
19	IN	Trigger input 3 (TRIG-2A)	Trigger input 11 (TRIG-6A)		
17	IN	Trigger input 4 (TRIG-2B)	Trigger input 12 (TRIG-6B)		
15	IN	Trigger input 5 (TRIG-3A)	Trigger input 13 (TRIG-7A)		
13	IN	Trigger input 6 (TRIG-3B)	Trigger input 14 (TRIG-7B)		
11	IN	Trigger input 7 (TRIG-4A)	Trigger input 15 (TRIG-8A)		
9	IN	Trigger input 8 (TRIG-4B)	Trigger input 16 (TRIG-8B)		
7	OUT	GP Output 1	GP Output 5	<ul style="list-style-type: none"> Active level is set with the INLVL command. Default is active low (see n.o. switch in diagram above). 	<ul style="list-style-type: none"> Active level is set with the INLVL command. Default is active low (see n.o. switch in diagram above).
5	OUT	GP Output 2	GP Output 6		
3	OUT	GP Output 3	GP Output 7		
1	OUT	GP Output 4	GP Output 8		

(GP=general purpose)

* All even number pins are connected to isolated logic ground.

** The VINref, TRIG-P, and GND terminals are located on the screw-terminal connector on top of the 6K chassis.

Trigger Input Connections

Connection to a Sinking Output Device

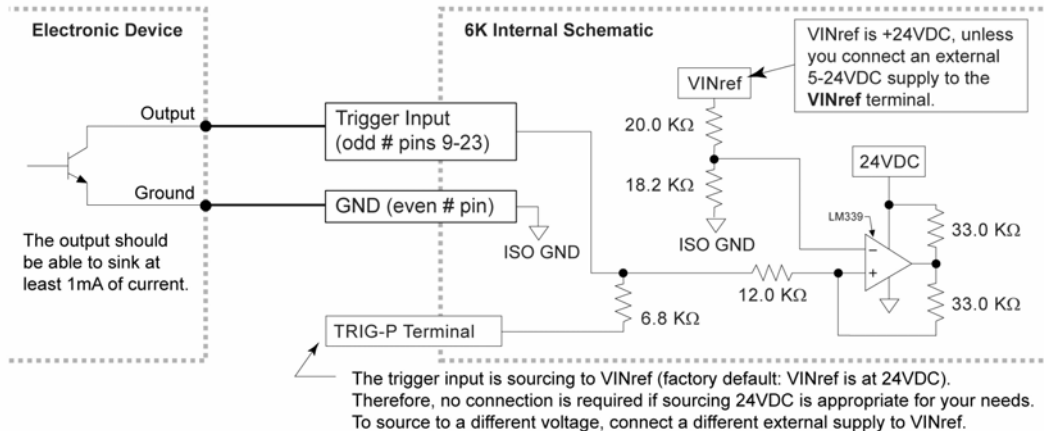

Connection to a Sourcing Output Device

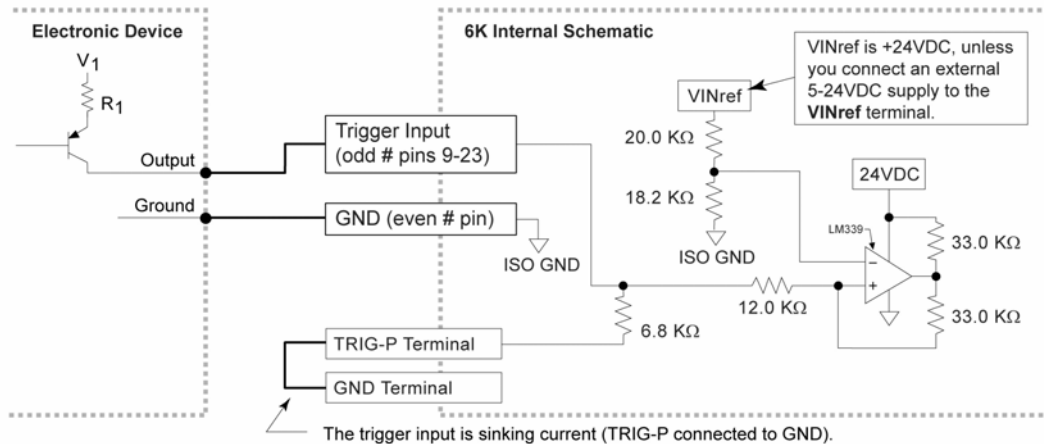

Connection to a Combination of Sinking and Sourcing Outputs

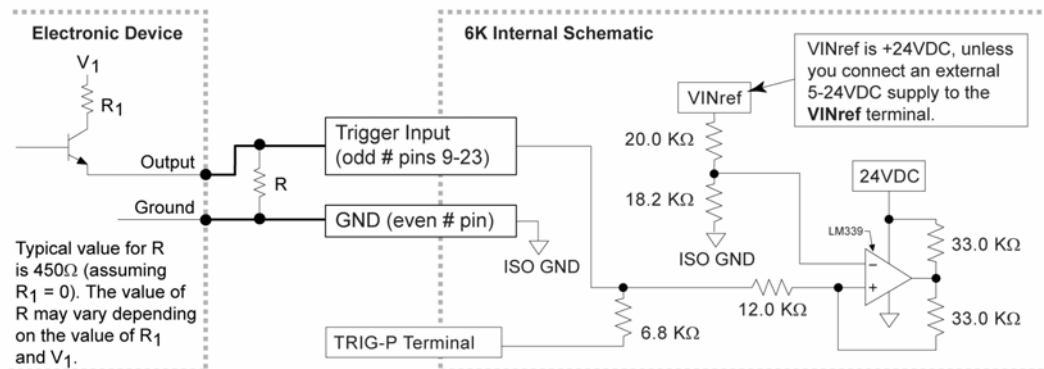

If you are connecting to a combination of sinking and sourcing output, connect the VINref terminal to the voltage supply (factory default is internally connected to 24 VDC) to accommodate the sinking outputs. Then for each input connected to a sourcing output, wire an external resistor between the trigger input and GND. The resistor provides a path for current to flow from the device when the output is active.

Programming Tip: If connecting to sinking output, set the trigger's INLVL setting to active low (INLVL0). If connecting to a sourcing output, set the trigger's INLVL setting to active high (INLVL1). Thus, when the output is active, the TIN/IN status will report a "1" (indicates that the input is active), regardless of the type of output that is connected.

Programmable Output Connections

Connection to a Sinking Input (active high)

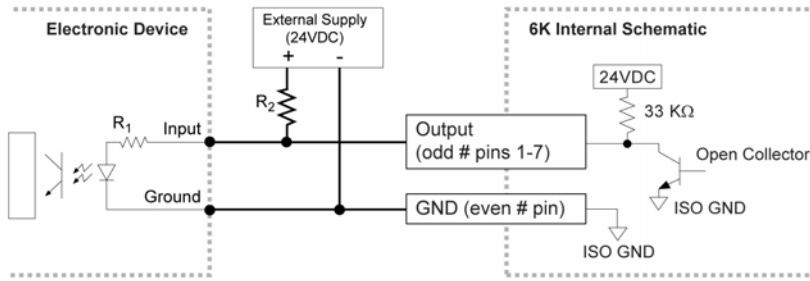

Connection to a Sourcing Input (active low)

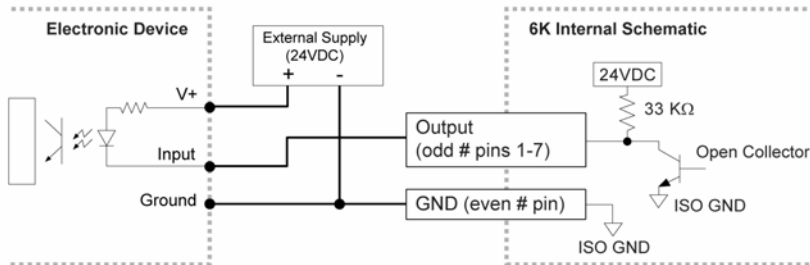

Connection to a Combination of Sinking & Sourcing Inputs

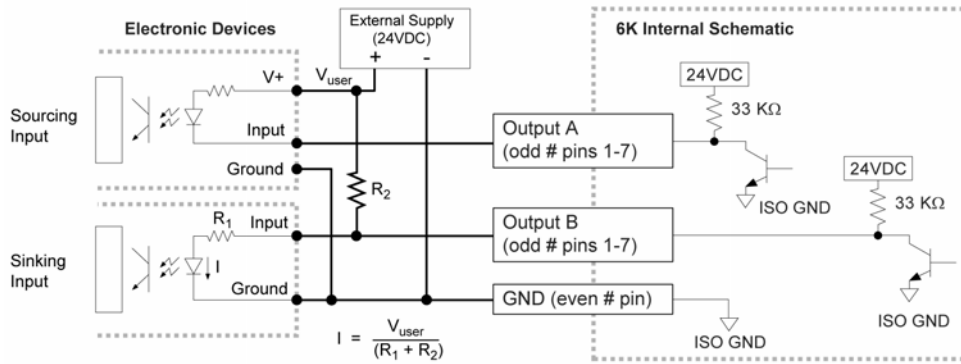

Connection to an Inductive Load (active low)

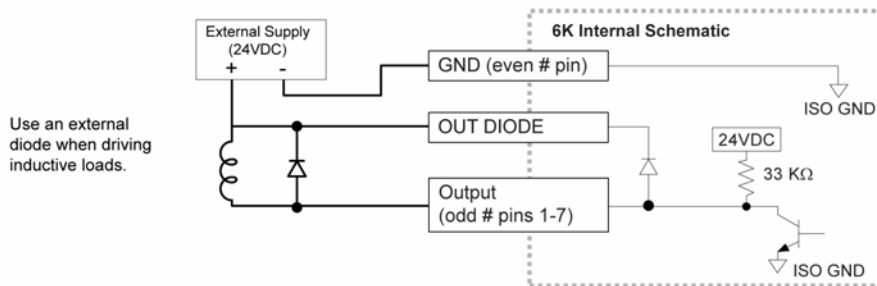

Programming Tip: If connecting to an active-high sinking input, set the output's `OUTLVL` setting to active high (`OUTLVL1`). If connecting to an active-low sourcing input, set the output's `OUTLVL` setting to active low (`OUTLVL0`). Thus, when the 6K's output is activated, current will flow through the attached input and the `TOUT/OUT` status will report a "1" (indicates the output is active), regardless of the type of input that is connected.

Communication Interface

Communication Interface Options

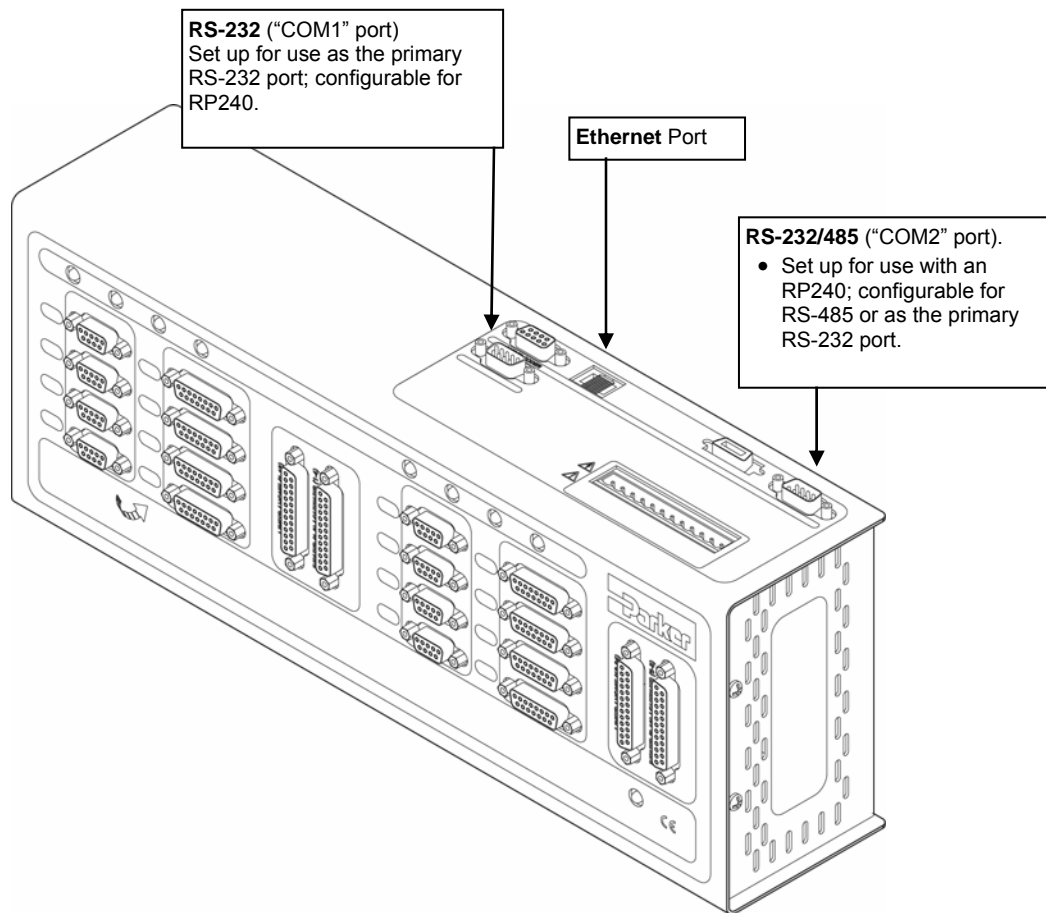

Using Multiple Ports

You can communicate to either the Ethernet port or the RS-232 port (COM1) at any given time; the port that you communicate to first is the only one that is recognized until you cycle power.

You can communicate to the Ethernet port or the RS-232 port (COM1) while the 6K is also communicating with an RP240 via the RS-232/485 port (COM2).

RS-232 Communication

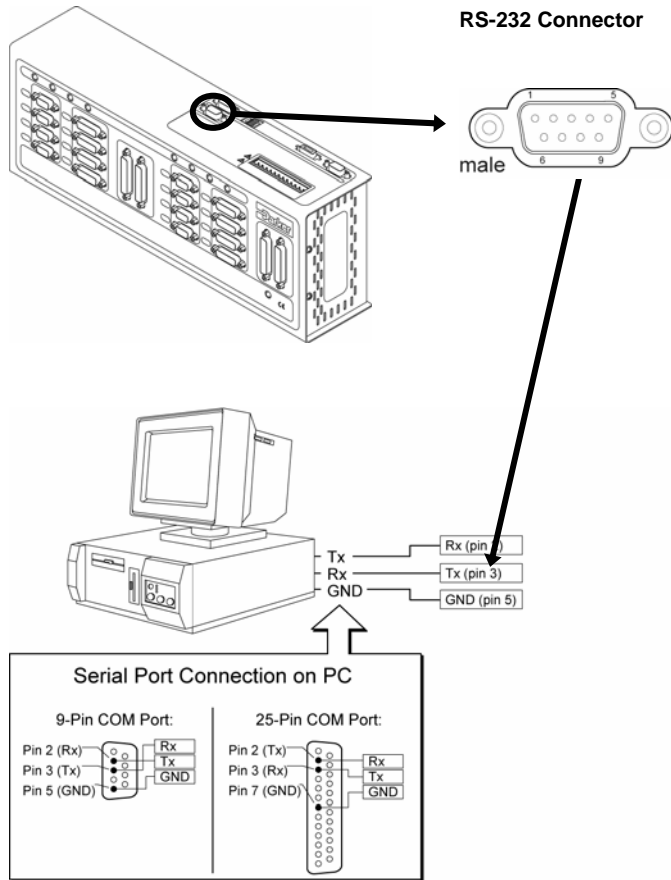

Pin Outs for RS-232 Communication

Pin	Description
2	Rx (receive). Connect to Tx on your computer.
3	Tx (transmit). Connect to Rx on your computer.
5	GND (isolate ground). Connect to GND on your computer.

Maximum RS-232 cable length is 50 feet (15.25 meters). The 6K, by default, communicates at 9600 baud. To change this setting, use the `BAUD` command. To establish unique addresses for daisy-chained units, use the `ADDR` command.

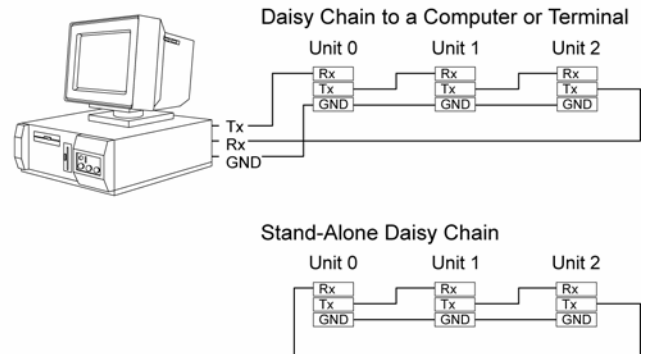

Ethernet Communication

NOTES

- Status LEDs:
Green LED is on when the Ethernet physical connection is OK.
Yellow LED is on when the 6K is transmitting over the Ethernet interface.
- Connect to a standard 10Mbps Ethernet card. IP address default is 192.168.10.30. To change the IP address, use the `NTADDR` command. To ascertain the Ethernet address, use the `TNTMAC` command.

Direct PC to 6K Connection

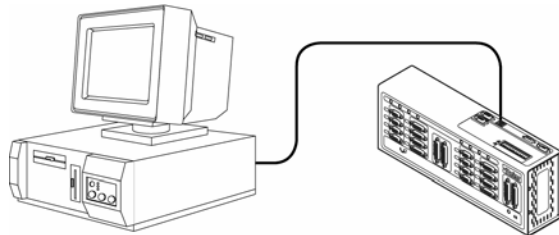

NOTE: Use a "Crossover" Ethernet (10Base-T) cable. A 10-foot cable is provided in the ship kit (p/n 71-017635-01).

Network Hub Connection

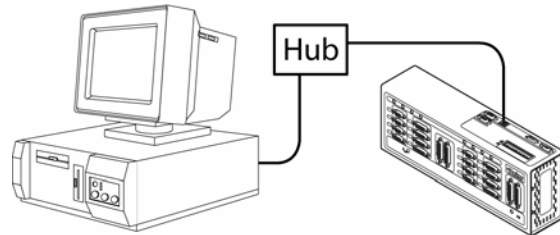

NOTE: Use a "Straight-Through" Ethernet (10Base-T) cable.

RS-485 Communication

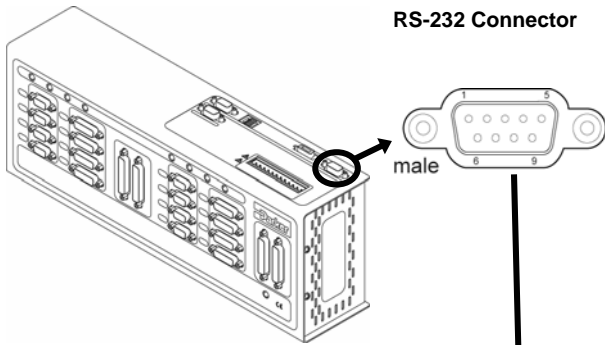

RS-232 Connector

Pin Outs for RS-485 Communication

Pin	Description
1	Rx + (also called RD B)
4	Tx + (also called TD B)
6	GND (isolate ground)
7	Rx - (also called RD A)
8	Tx - (also called TD A)

- Maximum RS-485 cable length is 4000 feet (1220 meters).
- To establish unique addresses for multi-drop units, use the ADDR command.
- Use termination resistors at both ends of the multi-drop. Keep stubs as short as possible.
- Recommended cables: 2-wire: Belden 9841
4-wire: Belden 9842
- Refer to the diagrams below (or page 5) for necessary DIP switch settings for 2-wire and 4-wire configuration.

4-Wire Connections (plus ground):

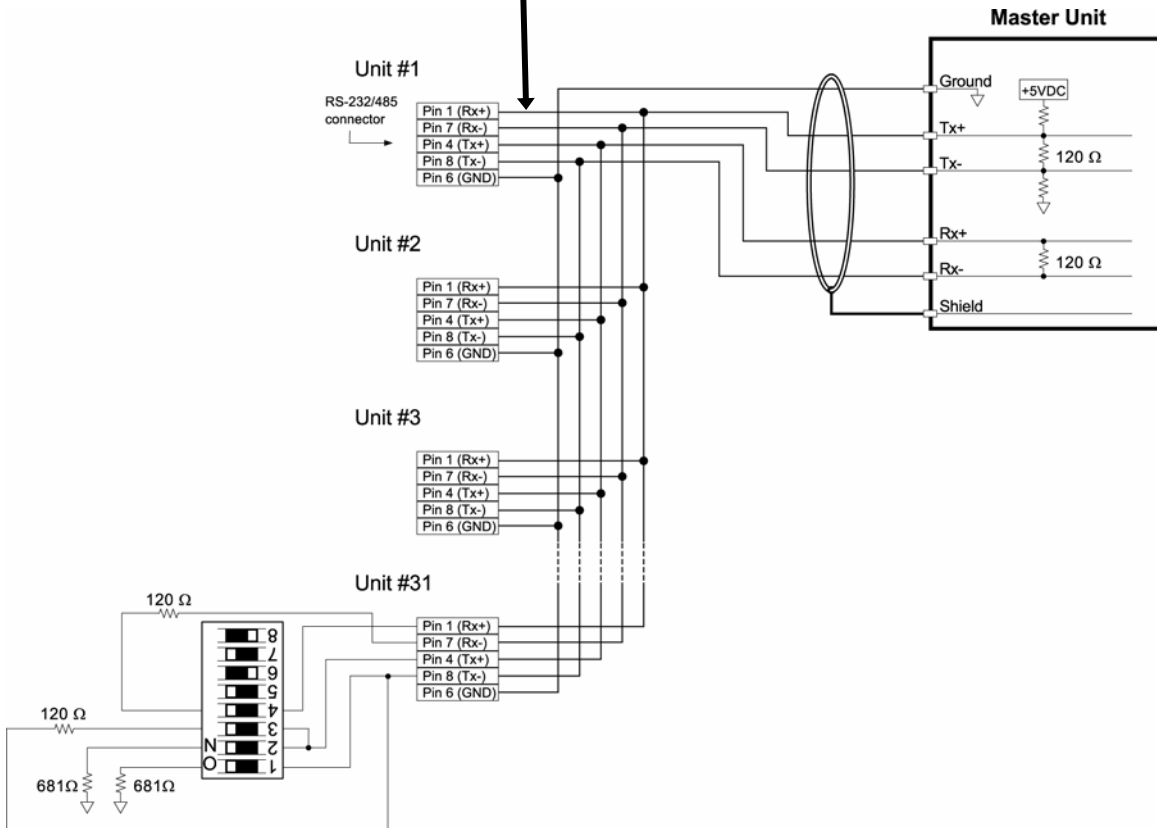

The DIP switch shown above is configured for RS-485 4-wire. DIP switches 1-4 select internal resistor values (ON selects the resistor). Use these resistors only for the last unit (or for a single unit). Refer to page 5 for instructions on how to access and set the switches.

2-Wire Connections (plus ground):

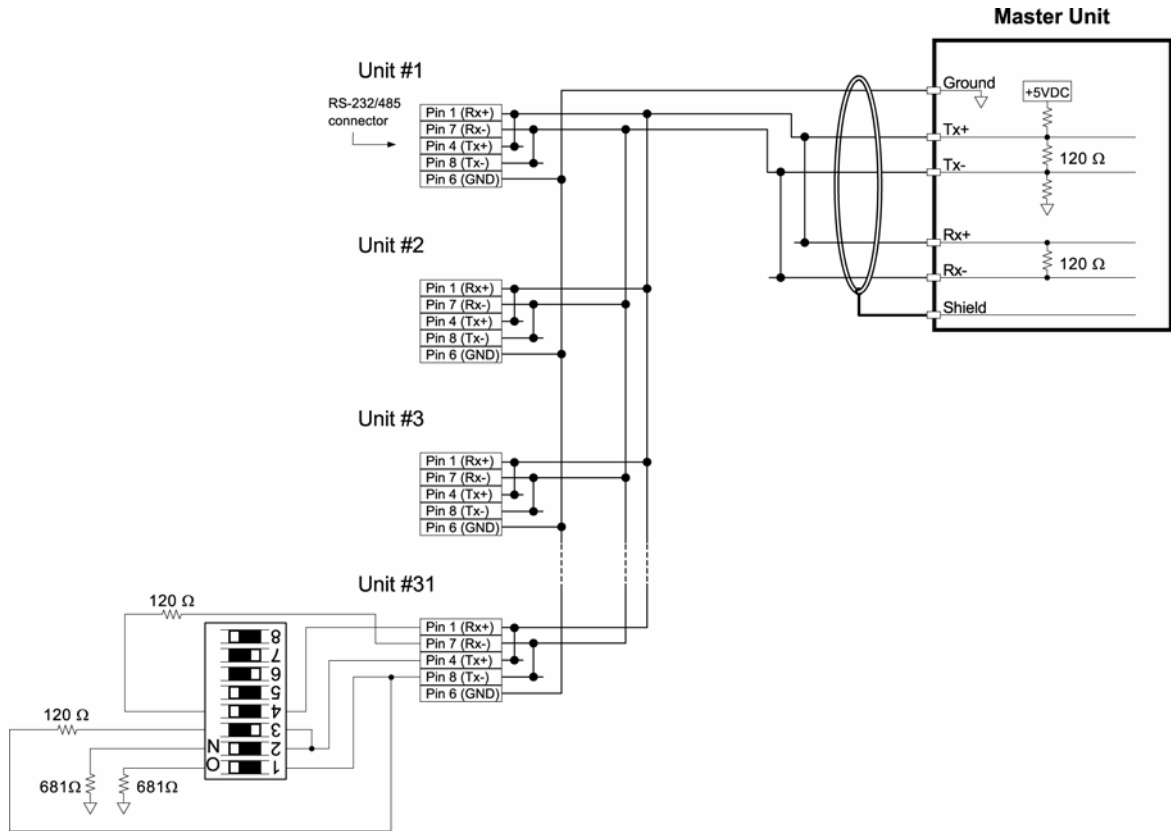

The DIP switch shown above is configured for RS-485 2-wire.
 DIP switches 1-4 select internal resistor values (ON selects the resistor).
 Use these resistors only for the last unit (or for a single unit).
 Refer to page 5 for instructions on how to access and set the switches.

RP240 Remote Operator Panel

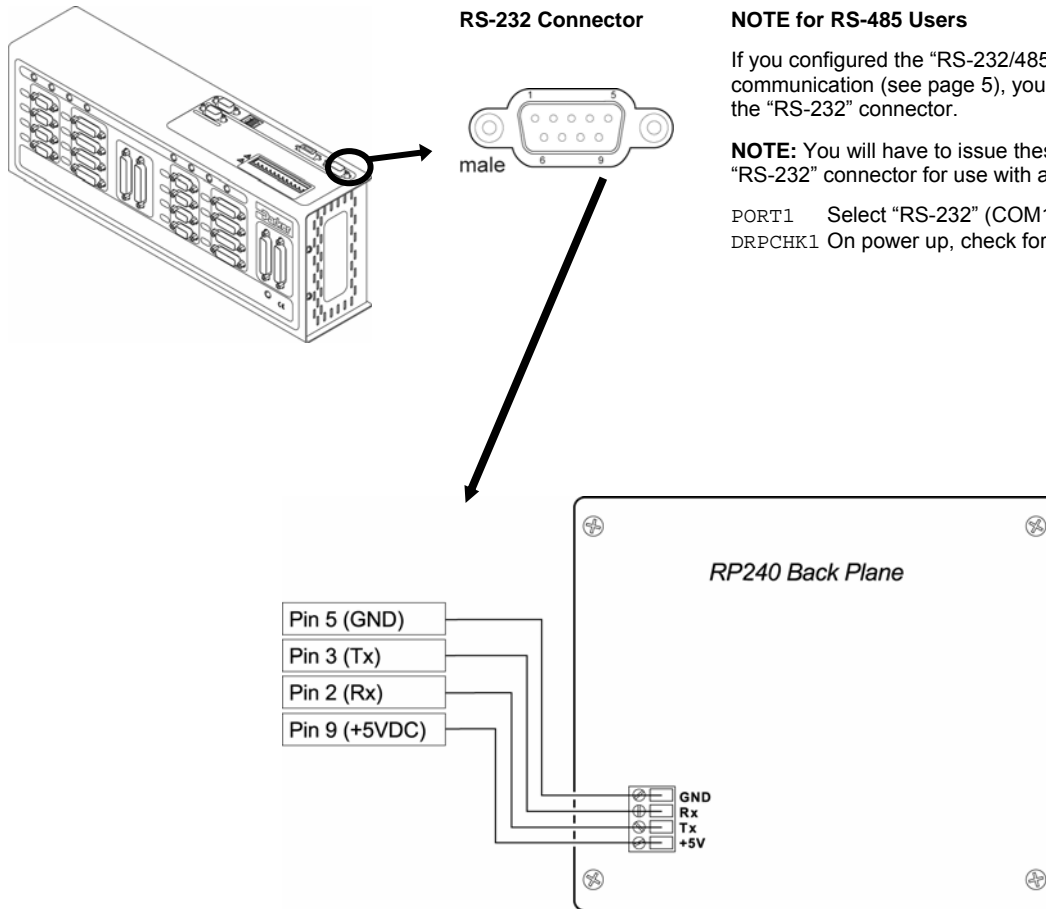

NOTE for RS-485 Users

If you configured the “RS-232/485” connector for RS-485 communication (see page 5), you must connect the RP240 to the “RS-232” connector.

NOTE: You will have to issue these commands to configure the “RS-232” connector for use with an RP240:

PORT1 Select “RS-232” (COM1) as the affected
DRPCHK1 On power up, check for RP240 on COM1.

NOTE: Refer to the *Model RP240 User Guide* for RP240 specifications and mounting instructions.

Expansion I/O

The 6K product allows you to expand your system I/O by connecting up to eight EVM32 expansion I/O bricks. EVM32 bricks are sold separately from the 6K controller. Each I/O brick can hold from 1 to 4 of these I/O SIM modules in any combination:

- Digital Inputs SIM (8 inputs)
- Digital Outputs SIM (8 outputs)
- Analog Inputs SIM (8 inputs)

For information about connecting the expansion I/O, see Appendix B, page 45.

24 VDC Power Input

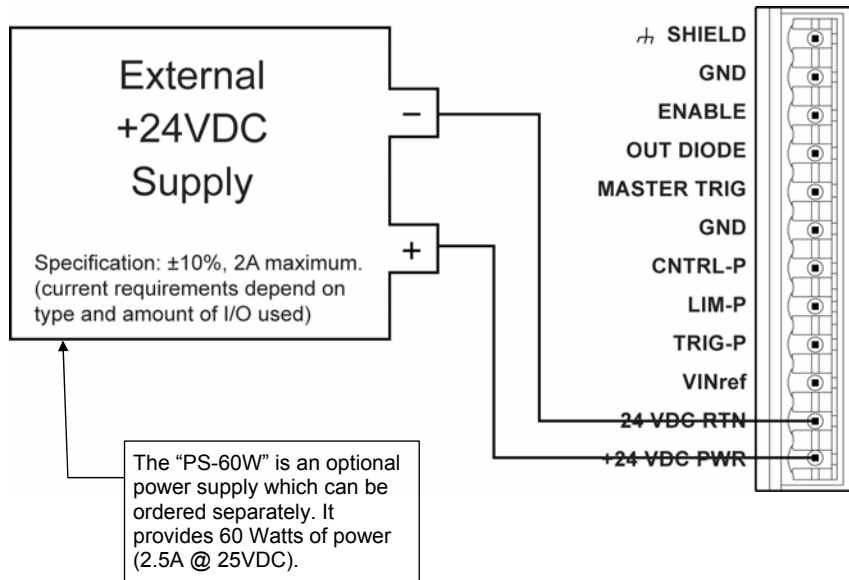
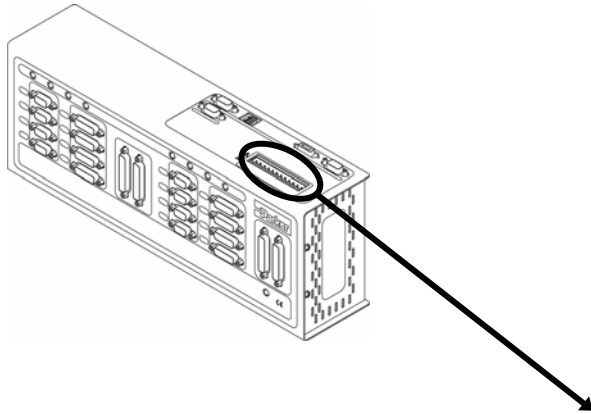

Guide to Power Requirements

6K2 or 6K4.....	24 Watts (1A @ 24 VDC)
6K6 or 6K8.....	36 Watts (1.5A @ 24 VDC)
For each encoder.....	Add 1.5 Watts
For each output.....	Add ≤ 7.5 Watts (up to 300 mA/output)

For example, a 6K4 with 4 encoders connected and 4 digital outputs (300 mA @ 24 VDC) requires 60 Watts of power.

Testing the Installation



Warning — This test procedure allows you to control your system I/O and produce motion. Therefore, you should make sure that exercising the I/O will not damage equipment or injure personnel.

Test Setup

1. If you haven't already done so, made the necessary communication connections (see page 28).
2. Install Motion Planner (CD is provided in your ship).
3. Launch Motion Planner and click on the "Terminal" window tab to view the terminal emulator. You now have live communication with the 6K product.

Connections	Test Procedure	Response Format (left to right)
End-of-travel and Home Limits	<p>NOTE: If you are not using end-of-travel limits, issue the Disable Limits (@LHØ) command and ignore the first two bits in each response field.</p> <ol style="list-style-type: none"> 1. Enable the hardware end-of-travel limits with the @LH3 command. 2. Close the end-of-travel switches and open the home switches. 3. Enter the TLIM command. The response should be *TLIM11Ø_11Ø_11Ø ... 4. Open the end-of-travel switches and close the home switches. 5. Enter the TLIM command. The response should be *TLIMØØ1_ØØ1_ØØ1 ... 6. Close the end-of-travel switches and open the home. 7. Enter the TLIM command. The response should be *TLIM11Ø_11Ø_11Ø ... 	<p>TLIM response:</p> <p>bit 1 = Axis 1 POS limit bit 2 = Axis 1 NEG limit bit 3 = Axis 1 HOM limit bit 4 = Axis 2 POS limit bit 5 = Axis 2 NEG limit bit 6 = Axis 2 HOM limit and so on (3 inputs/axis)</p> <p>"POS" means positive travel. "NEG" means negative travel. "HOM" means home.</p>
Encoder (not coupled to the load or motor)	<ol style="list-style-type: none"> 1. Enter these commands, (preset the RETURN key after each command): ENCCNT1, L, TPE, T. 3, and then LN. This will begin a continuous display of all encoder positions. Press the RETURN key to move the display to the next line and save the current value. 2. Manually rotate the encoder shaft and verify that the position changes as you rotate the encoder shaft. If you connected the encoder as instructed earlier in this chapter, moving the shaft clockwise should increase the position reading. If the reading does not change, or if the direction is reversed, check the connections. If the direction is reversed, swap the A+ and A- connections. 3. When finished, enter the ^K (ctrl-K) command to stop the continuous report-back. 	<p>TPE response (encoder counts):</p> <p>±encoder1, ±encoder1, ...</p> <p>Direction of rotation:</p>
Trigger Inputs	<ol style="list-style-type: none"> 1. Open the trigger input switches or turn off the device driving the inputs. 2. Enter the TIN command. Response should be *TINØØØØ_ØØØØ_Ø or *TINØØØØ_ØØØØ_ØØØØ_ØØØØ_Ø. 3. Close the trigger input switches or turn on the device driving the inputs. 4. Enter the TIN command. Response should be *TIN1111_1111_1 or *TIN1111_1111_1111_1111_1. 	<p>TIN response:</p> <p>Bits 1-n, from left to right, represent trigger inputs 1-n. Bit #17 represents the Master Trigger ("MASTER TRG"). The 6K2 & 6K4 have 9 inputs, the 6K6 & 6K8 have 17 inputs.</p>
Onboard Outputs	<ol style="list-style-type: none"> 1. Enter the @OUT1 command to turn on (sink current on) all programmable outputs. Verify that the device(s) connected to the outputs activated properly. 2. Enter the TOUT command. Response should be *TOUT1111 or *TOUT1111_1111. 3. Enter the @OUTØ command to turn off all programmable outputs. Verify that the device(s) connected to the outputs de-activated properly. 4. Enter the TOUT command. Response should be *TOUTØØØØ or *TOUTØØØØ_ØØØØ. 	<p>TOUT response:</p> <p>Bits 1-n, from left to right, represent outputs 1-n. The 6K2 & 6K4 have 4 outputs, the 6K6 & 6K8 have 8 outputs.</p>
RP240	<ol style="list-style-type: none"> 1. Cycle power to the 6K. 2. If the RP240 is connected properly, the RP240's status LED should be green and one of the lines on the computer or terminal display should read *RP24Ø CONNECTED. If the RP240's status LED is off, check to make sure the +5V connection is secure. If the RP240's status LED is green, but the message on the terminal reads *NO REMOTE PANEL, the RP240 Rx and Tx lines are probably switched. Remove power and correct. 3. Assuming you have not written a program to manipulate the RP240 display, the RP240 screen should display the following: <div style="border: 1px solid black; padding: 5px; text-align: center; margin: 10px 0;"> <p>COMPUMOTOR 6Kn CONTROLLER RUN JOG STATUS DRIVE DISPLAY ETC</p> </div>	<p>ASSUMPTIONS</p> <p>RP240 connected to the COM 2 ("RS-232/485"). COM 2 configured for RP240. To verify, type these commands: PORT2 <cr> DRPCHK<cr></p> <p>The system response should report "*DRPCHK3".</p>
Enable Input	<ol style="list-style-type: none"> 1. Open the enable input (ENABLE) switch. 2. Enter the TINO command. Response should be *TINOØØØØ_ØØØØ. 3. Close the ENABLE switch. 4. Enter the TINO command. Response should be *TINOØØØØ_Ø1ØØ. 	<p>TINO response:</p> <p>bit 6 = Enable (ENABLE) input, all other bits are not used.</p>

What's Next?

By now, you should have completed the following tasks, as instructed earlier in this chapter:

1. Check the ship kit to make sure that you have all the items (see page 3).
2. Review the general specifications table (see page 4).
3. (optional) Set internal DIP switches for using the "RS-232/485" connector as an RS-485 serial port (default function is RS-232 and configured for connection to an RP240).
4. Mount the 6K controller (see page 6).
5. Connect all electrical system components (see pages 8-33).
Installation instructions for the EVM32 expansion I/O are provided on page 45.
6. Test the installation (see page 34).

Next...

1. Mount the motors and/or couple the loads.
2. Tune any servo axes or axes using the ZETA drive.
Use the tuning facility in Motion Planner (see page 59).

And Finally...

After completing all necessary hardware installation tasks, you are ready to program your motion control functions. Knowing your system's motion control requirements, refer now to the *6K Series Programmer's Guide* for descriptions of the 6K's software features and instructions on how to implement them in your application. Be sure to keep the *6K Series Command Reference* at hand as a reference for the 6K Series command descriptions.

For assistance with your programming effort, we recommend that you use the programming tools provided in Motion Planner for Windows (found in your ship kit).

CHAPTER TWO

Troubleshooting

IN THIS CHAPTER

Troubleshooting basics	37
Solutions to common problems	38
Resolving RS-232 & RS-485 communication problems	42
Product return procedure	43

Troubleshooting Basics

When your system does not function properly (or as you expect it to operate), the first thing that you must do is identify and isolate the problem. When you have accomplished this, you can effectively begin to resolve the problem.

The first step is to isolate each system component and ensure that each component functions properly when it is run independently. You may have to dismantle your system and put it back together piece by piece to detect the problem. If you have additional units available, you may want to exchange them with existing components in your system to help identify the source of the problem.

Determine if the problem is mechanical, electrical, or software-related. Can you repeat or re-create the problem? Random events may appear to be related, but they are not necessarily contributing factors to your problem. You may be experiencing more than one problem. You must isolate and solve one problem at a time.

Log (document) all testing and problem isolation procedures. You may need to review and consult these notes later. This will also prevent you from duplicating your testing efforts.

Once you isolate the problem, refer to the problem solutions contained in this chapter. If the problem persists, contact your local technical support resource (see *Technical Support* below).

Technical Support

If you cannot solve your system problems using this documentation, contact your local Automation Technology Center (ATC) or distributor for assistance.

If you need to talk to our in-house application engineers, please contact us at the numbers listed on the inside cover of this manual.

Solutions to Common Problems

Note: Some software-related causes are provided because it is sometimes difficult to identify a problem as either hardware or software related.

Problem	Cause	Solution
Communication (Ethernet) errors.	1. Ethernet card not installed correctly.	1. Refer to the user instructions that came with your Ethernet card.
	2. Ethernet or IP address conflict.	2. Refer to the configuration instructions in the <i>6K Programmer's Guide</i> .
	3. Connection to Ethernet port is compromised or mis-wired.	3. Check the connections according to page 28.
Communication (serial) not operative, or receive garbled characters. NOTE: Refer also to the diagnostic procedures on page 42.	1. Improper interface connections or communication protocol.	1. Check the connections according to page 28.
	2. COM port disabled.	2.a. Enable serial communication with the <code>E1</code> command. 2.b. If using RS-485, make sure the internal jumpers are set accordingly (see page 5). Make sure COM 2 port is enabled for sending 6K language commands (execute the <code>PORT2</code> and <code>DRPCHK0</code> commands).
	3. In daisy chain, unit may not be set to proper address.	3. Verify proper application of the <code>ADDR</code> command.
Direction is reversed. (stepper axes only)	1. Direction connections to the drive are reversed.	1. Switch DIR+ with DIR- connection to drive (see page 17).
	2. Phase of step motor reversed (motor does not move in the commanded direction).	2. Switch A+ with A- connection from drive to motor. SOFTWARE ALTERNATIVE: If the motor (and the encoder if one is used) is reversed, use the <code>CMDDIR1</code> command to reverse the polarity of both the commanded direction and the polarity of the encoder counts).
	3. Phase of encoder reversed (reported <code>TPE</code> direction is reversed).	3. Swap the A+ and A- connection at the ENCODER connector.
Direction is reversed, servo condition is stable. (servo axes only)	1. Command output (CMD) connections <u>and</u> feedback device connections or mounting are reversed.	1. Software remedy: Issue the <code>CMDDIR1</code> command to the affected axis. This reverses the polarity of the commanded direction and the feedback direction so that servo stability is maintained. Hardware remedy: Switch CMD- with the CMD+ connection to drive or valve (if your drive or valve does not accept differential outputs this will not work). You will also have to change the feedback device wiring or mounting so that it counts in same direction as the commanded direction.
Direction is reversed, servo condition is <u>unstable</u> . (servo axes only)	1. Not tuned properly.	1. Refer to tuning instructions on page 59.
	2. Phase of encoder reversed or mounting of ANI input is such that it counts in the opposite direction as the commanded direction.	2. Software remedy for encoder feedback only: For the affected axis, issue <code>ENCPOL1</code> . Hardware remedy: If using encoder feedback, swap the A+ and A- connections to the 6K product. If using ANI feedback, change the mounting so that the counting direction is reversed.

Problem	Cause	Solution
Distance, velocity, and accel are incorrect as programmed.	1. Incorrect resolution setting.	<p>1.a. Stepper axes: Set the resolution on the to match the 6K product's <code>DRES</code> command setting (default <code>DRES</code> setting is 25,000 steps/rev).</p> <p>1.b. Match the 6K product's <code>ERES</code> command setting (default <code>ERES</code> setting is 4,000 counts/rev) to match the post-quadrature resolution of the encoder.</p> <p><code>ERES</code> values for Parker Hannifin encoders:</p> <p>Stepper axes:</p> <p>RE, -RC, -EC, & -E Series Encoders:..... <code>ERES4000</code> HJ Series Encoders: <code>ERES2048</code></p> <p>Servo axes (SM, N or J Series Servo Motors):</p> <p>SM/N/JxxxxD-xxxx: <code>ERES2000</code> SM/N/JxxxxE-xxxx: <code>ERES4000</code></p> <p>Dynaserv (stepper and servo):</p> <p>DR10xxB..... <code>ERES507904</code> DR1xxxE..... <code>ERES614400</code> DR1xxxA..... <code>ERES819200</code> DR5xxxB..... <code>ERES278528</code> DR5xxxA..... <code>ERES425894</code> DM10xxB..... <code>ERES655360</code> DM1xxxA..... <code>ERES1024000</code> DM1004x..... <code>ERES655360</code></p>
	2. Pulse width too narrow. (stepper axes)	2. Set pulse width to drive specifications using the <code>PULSE</code> command.
	3. Wrong scaling values.	3. Check the scaling parameters (<code>SCALE1</code> , <code>SCLA</code> , <code>SCLD</code> , <code>SCLV</code> , <code>SCLMAS</code>).
Erratic operation.	1. Electrical Noise.	1. Reduce electrical noise or move product away from noise source.
	2. Improper shielding.	2. Shield for noise immunity.
	3. Improper wiring.	3. Check wiring for opens, shorts, & mis-wired connections.
Feedback device (encoder or ANI) counts missing.	1. Improper wiring.	1. Check wiring.
	2. Feedback device slipping.	2. Check and tighten feedback device coupling.
	3. Encoder too hot.	3. Reduce encoder temperature with heatsink, thermal insulator, etc.
	4. Electrical noise.	4a. Shield wiring. 4b. Use encoder with differential outputs.
	5. Encoder frequency too high.	5. Peak encoder frequency must be below 12.0 MHz post-quadrature. Peak frequency must account for velocity ripple.
Joystick mode: Motor does not move.	1. Joystick Release input not grounded.	<p>1.a. If an input is not assigned the "Joystick Release" input function, do so with the <code>INFNCi-M</code> command.</p> <p>1.b. Ground the Joystick Release input.</p>
	2. Improper wiring.	2. Check wiring for opens, shorts, and mis-wired connections.

Problem	Cause	Solution
LEDs:	<i>All other LED states indicate hardware conditions; refer to your product's Installation Guide for details.</i>	
"POWER" LED is off.	1. No power.	1. Check 24 VDC power connection and restore power.
"POWER" LED is red.	1. General fault. 2. ENABLE input not grounded.	1. Reset the controller by one of these methods: <ul style="list-style-type: none"> • Cycle power • Issue the <code>RESET</code> command 2. Ground the ENABLE input.
An "AXIS" LED is on (red).	1. Drive was commanded to shut down (<code>DRIVE0</code>). If Disable Drive on Kill mode is enabled (<code>KDRIVE1</code>), a kill command or kill input will also disabled the drive. 2. Servo Axes: Maximum position error (<code>SMPER</code> value) exceeded. Could be caused by disconnected or mis-mounted feedback device.	1. Re-enable the drive by sending a <code>DRIVE1</code> command to the affected axis. 2. (verify position error by checking to see if <code>TAS/TASF</code> bit #23 is set) Check feedback device connection and mounting and re-enable drive by sending <code>DRIVE1</code> command to the affected axis.
Motion does not occur.	1. "AXIS" LED is red, or "POWER" LED is off or red. 2. End-of-travel limits are active. 3. Step pulse too narrow for drive to recognize (stepper axes only). 4. Drive fault level incorrect. 5. Improper wiring. 6. ENABLE input is not grounded. 7. Load is jammed. 8. No torque from motor. 9. Max. position error (<code>SMPER</code> value) exceeded. (servo axes only) 10. Drive has activated the drive fault input.	1. See LED troubleshooting as noted above. 2.a. Move load off of limits or disable limits by sending the <code>LH0</code> command to the affected axis. 2.b. Software limits: Set <code>LSPOS</code> to a value greater than <code>LSNEG</code> . 3. Set pulse width to drive specifications using the <code>PULSE</code> command. 4. Set drive fault level using the <code>DRFLVL</code> command. 5. Check drive fault & limit connections. Stepper Axes: check step and direction connections. Servo Axes: check command and shutdown connections. 6. Ground the ENABLE input connection. 7. Remove power and clear jam. 8. See problem: <i>Torque, loss of</i> . 9. Check to see if <code>TAS/TASF</code> bit #23 is set, and issue the <code>DRIVE1</code> command to the axis that exceeded the position error limit. 10. Check to see if <code>TAS/TASF</code> bit #14 is set, and check the drive fault level (<code>DRFLVL</code>).
Power-up Program does not execute.	1. ENABLE input is not grounded. 2. <code>STARTP</code> program is not defined.	1. Ground the ENABLE input to GND and reset the product. (see page 9) 2. Check the response to the <code>STARTP</code> command. If no program is reported, define the <code>STARTP</code> program and reset (refer to the <code>STARTP</code> command description).

Problem	Cause	Solution
Runaway (SERVOS ONLY)	1. Direction connections reversed. (if encoder counts positive when turned clockwise or extended).	1. Switch CMD– with the CMD+ connection to drive or valve. NOTE: The CMD+/- Connection is not differential. Do not connect CMD+ to ground on your drive.
Torque, loss of.	1. Improper wiring. 2. No power to drive 3. Drive failed. 4. Drive faulted. 5. Shutdown issued to drive.	1. Check wiring to the drive, as well as other system wiring. 2. Check power to drive. 3. Check drive status. 4. Check drive status. 5. Re-enable drive by sending the <code>DRIVE1</code> command to the affected axis.

Resolving Serial Communication Problems

General Notes

Power up your computer or terminal BEFORE you power up the 6K.
Make sure the serial interface is connected as instructed on page 28. Shield the cable to earth ground at one end only. The maximum RS-232 cable length is 50 feet (15.25 meters).
RS-232: Handshaking must be disabled. Most software packages allow you to do this. You can also disable handshaking by jumpering some terminals on the computer's/ terminal's serial port: connect RTS to CTS (usually pins 4 and 5) and connect DSR to DTR (usually pins 6 and 20).
RS-485: Make sure the internal DIP switches are configured as instructed on page 5.

Test the Interface

1. Power up the computer or terminal and launch the terminal emulator.
2. Power up the 6K. A power-up message should be displayed, followed by a prompt (>).
3. Type "TREV" and press the ENTER key. (The TREV command reports the software revision.) The screen should now look as follows (if not, see Problem/Remedy table below).
*PARKER HANNIFIN 6K MOTION CONTROLLER

>TREV

*TREV92-016740-01-5.0 6K

Problem	Remedy (based on the possible causes)
No Response	<p>COM port not enabled for 6000 language communication. If RS-232 connected to "RS-232" connector : issue "PORT1" and "DRPCHKØ" commands. If RS-232 connected to "RS-232/485" connector: issue "PORT2" and "DRPCHKØ" commands. If RS-485 connected to "RS-232/485" connector: issue "PORT2" and "DRPCHKØ" commands. Serial communication may be disabled; enable with the E1 command. RS-232: Echo may be disabled; enable with the ECHO1 command. If you are using an RS-232 connection between the host computer and the master 6K connected to multiple 6Ks in an RS-485 multi-drop, make sure the master 6K has these settings executed in the order given (you should place these settings in your power-up STARTP program):</p> <pre>PORT1 (select RS-232 port, COM1, for configuration) ECHO3 (echo to both COM ports) PORT2 (select RS-232/485 port, COM2, for configuration) ECHO2 (echo to the other COM port, COM1)</pre> <p>Faulty wiring. See instructions on page 28. RS-485: verify internal DIP switch settings on page 5. Also check for shorts or opens. Is the cable or computer/terminal bad? Here's a test:</p> <ol style="list-style-type: none">1. Disconnect the serial cable from the 6K end only.2. Connect the cable's Rx and Tx lines together (this echoes the characters back to the host).3. Issue the TREV command. If nothing happens, the cable or computer/terminal may be faulty. <p>The controller may be executing a program. Issue the !K command or the <ctrl>K command to kill the program.</p>
Garbled Characters	<p>Verify setup: 9600 baud (range is 9600-1200), 8 data bits, 1 stop bit, no parity; RS-232: Full duplex; RS-485: Half duplex (verify internal DIP switch settings on page 5). RS-485: Transmission line not properly terminated. See page 5 for internal DIP switch settings. See page 28 for connections and calculating termination resistors (if not using the internal resistors via internal DIP switches). Faulty wiring. See instructions on page 28. RS-485: verify internal DIP switch settings on page 5. Also check for shorts or opens.</p>
Double Characters	Your terminal emulator is set to half-duplex; set it to full-duplex.

Product Return Procedure

- Step 1 Obtain the serial number and the model number of the defective unit, and secure a purchase order number to cover repair costs in the event the unit is determined by the manufacturers to be out of warranty.
- Step 2 Before you return the unit, have someone from your organization with a technical understanding of the 6K system and its application include answers to the following questions:
- What is the extent of the failure/reason for return?
 - How long did it operate?
 - Did any other items fail at the same time?
 - What was happening when the unit failed (e.g., installing the unit, cycling power, starting other equipment, etc.)?
 - How was the product configured (in detail)?
 - Which, if any, cables were modified and how?
 - With what equipment is the unit interfaced?
 - What was the application?
 - What was the system environment (temperature, enclosure, spacing, contaminants, etc.)?
 - What upgrades, if any, are required (hardware, software, user guide)?
- Step 3 Call for return authorization. Refer to the *Technical Assistance* phone numbers provided on the inside front cover of this document. The support personnel will also provide shipping guidelines.

Appendix A. VM25 Installation

The VM25 provides screw-terminal connections for the I/O on the 25-pin connectors, which are the "TRIGGERS/OUTPUTS" and "LIMITS/HOME" connectors. The VM25 comes with a 2-foot cable that provides easy connection between the VM25 and the 6K's 25-pin connector. The VM25 is ordered separately (part number is "VM25").

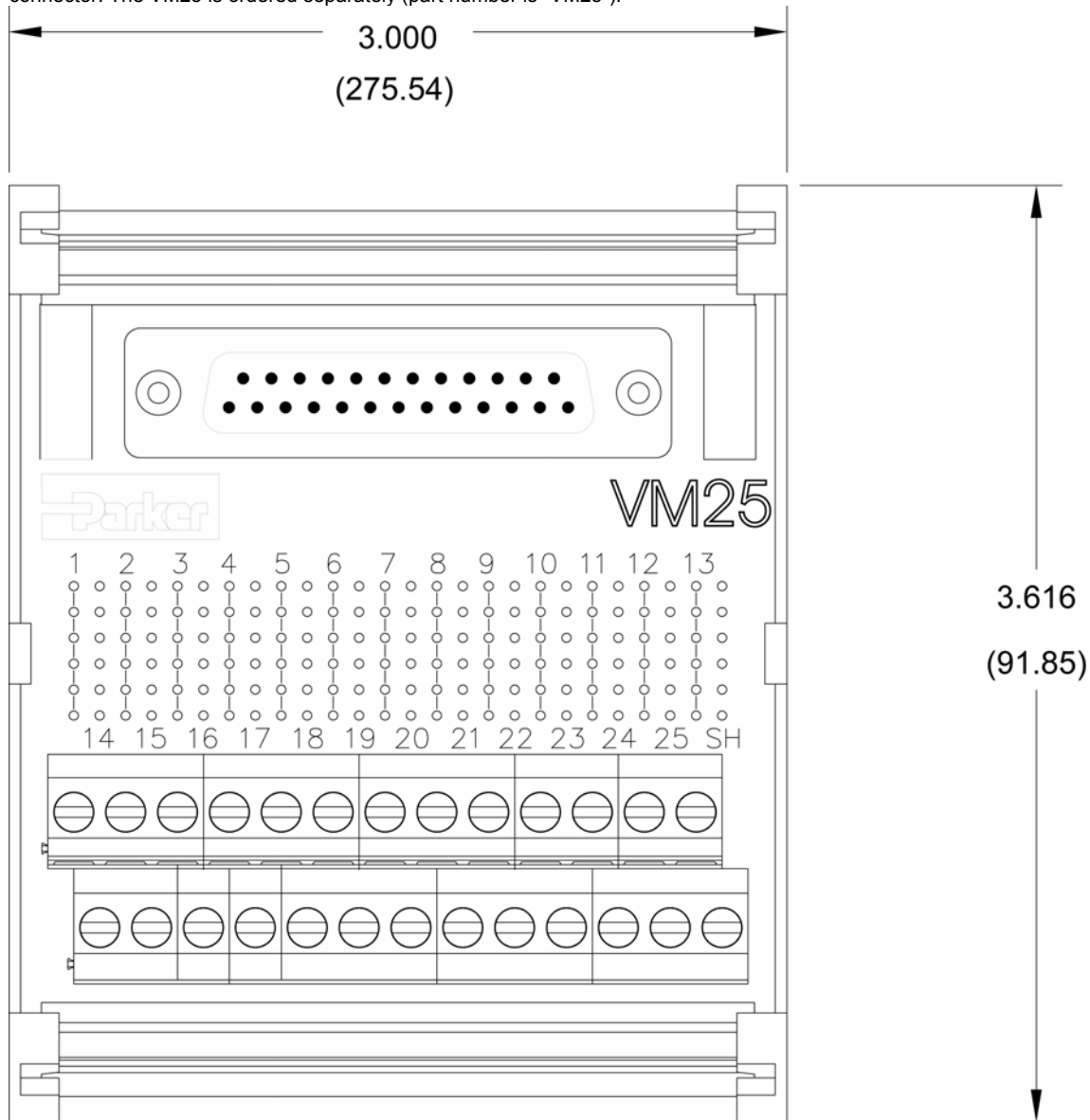

Appendix B. EVM32 Installation

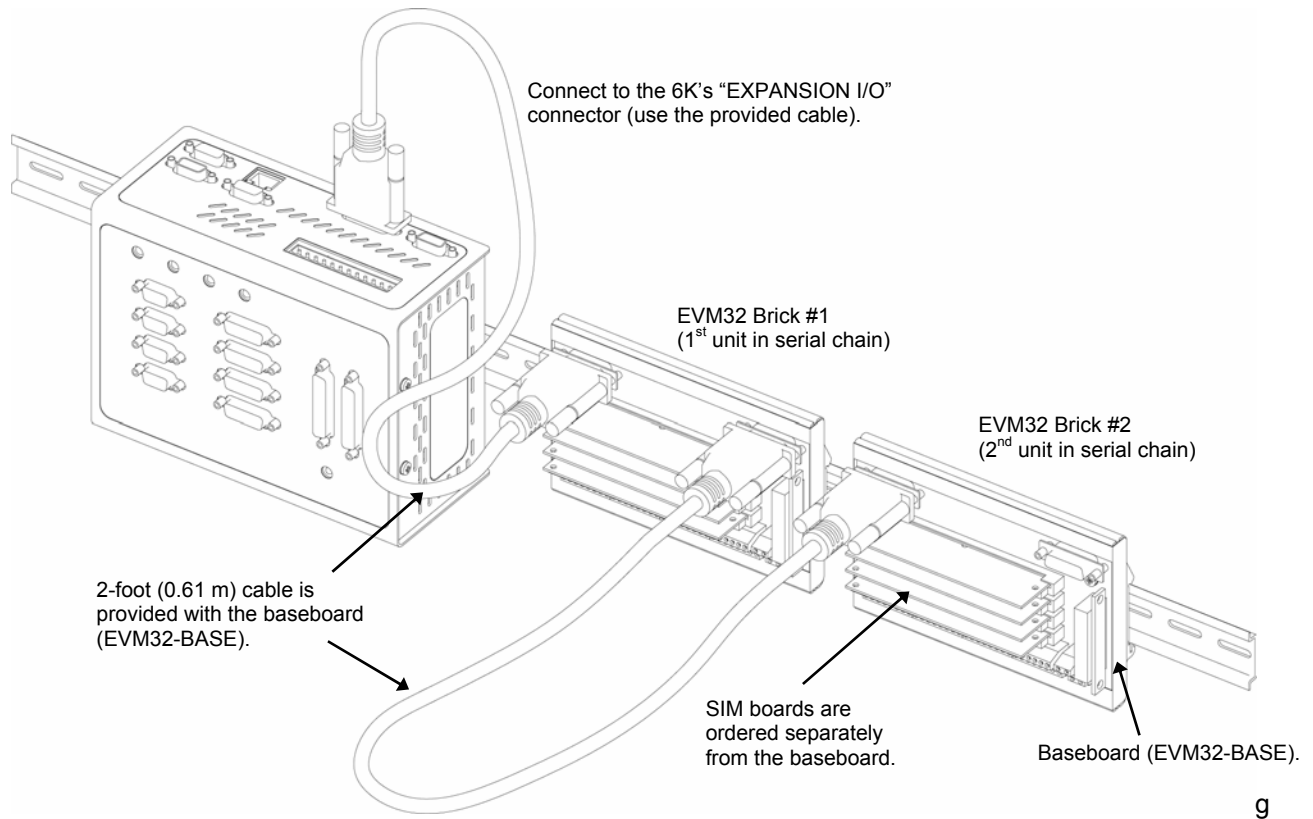

EVM32 Description

The EVM32-Base and EVM32-II is a family of I/O modules (or “bricks”) that is sold as accessories to the 6K Controllers. The EVM32 provides additional I/O for 6K controller. Up to eight DIN-rail mountable EVM32 bricks can be connected in a serial chain to the 6K. Each EVM32 brick can hold from 1 to 4 of the I/O SIM boards in any combination (each SIM board provides 8 I/O points, for a total of 32 I/O points per I/O brick):

- Digital inputs
- Digital outputs
- Analog inputs

Order an EVM32 brick and up to four I/O SIM boards per brick (see table below):

Product (p/n)	Description
EVM32-Base	EVM32 baseboard, extrusion with built-in DIN rail mount (includes 2-foot cable).
EVM32-II	EVM32 baseboard, extrusion with built-in DIN rail mount (includes 2-foot cable).
SIM8-IN-EVM32	Digital input SIM board (8 inputs). Color code: RED
SIM8-OUT-NPN	Digital output SIM board (8 outputs), sinking. Color code: BLUE
SIM8-OUT-PNP	Digital output SIM board (8 outputs), sourcing. Color code: BLUE
SIM8-OUT-SSR	Solid State Relay SIM board (8 outputs). Color code: BLUE
SIM8-OUT-HCR	High Current Relay SIM board (8 outputs). Color code: BLUE
SIM8-AN-IN	Analog (+/- 10V) input SIM board (8 inputs). Color code: GREEN
SIM8-AN-OUT	Analog (+/- 10V) output SIM board (8 outputs). Color code: BLACK
SIM8-IN	SIM board with 8 digital inputs. Color code: RED
SIM8-OUT-EVM32	SIM board with 8 digital outputs. Color code: BLUE
71-016949-02	2-foot cable for connection to 6K or between I/O bricks (included with EVM32-BASE)
71-016949-100	100-foot cable for connection to 6K or between I/O bricks

EVM32 Specifications

Parameter	Specification
Power (DC input)	
V+	User-supplied voltage that drives output circuitry.
V+ range	12-24 VDC. (If using SIM8-AN-OUT, you must use a 24 VDC supply.)
V+ current	1.8A @ 12 VDC or 0.9A @ 24 VDC; plus the sum of the load current on the PNP outputs.
Environmental	
Operating temperature.....	32 to 122°F (0 to 50°C)
Storage temperature.....	-22 to 185°F (-30 to 85°C)
Humidity.....	0 to 95% non-condensing
Dimensions (see dimension drawing on page 48).	
Digital Inputs (SIM8-IN-EVM32)Inputs are not optically isolated.	
Switching levels	Low \leq 1/3 V+ voltage; High \geq 2/3 V+ voltage.
Voltage range	Voltage range = 0-24 VDC. Voltage of input signals should not exceed voltage level of V+. (Input circuitry of EVM32 has diodes to protect against voltages that exceed V+, but performance may degrade.)
Sinking/Sourcing.....	Sinking: Connect jumper for selected SIM board to position 1. Sourcing: Connect jumper for selected SIM board to position 3 (factory default).
Impedance.....	6 K Ω , minimum. Requires input current (sinking or sourcing) of 0.111 mA per volt of user-supplied voltage to V+ (e.g., 2.67 mA if V+ = 24V).
Active level.....	Set by the 6K controller (INLVL command setting) — default is active low, but can be set to active high.
Input frequency.....	50 kHz (the maximum frequency is limited practically to 500 Hz by the 2 ms update rate of the 6K controller).
Status.....	Check with the TIO command. LED illuminates when at least [2/3 * V+] volts is present on the input: <ul style="list-style-type: none"> <input type="checkbox"/> If sinking (jumper in position 1), the default LED state is off. The LED illuminates when the voltage at the input is at least [2/3 * V+] volts. <input type="checkbox"/> If sourcing (jumper in position 3), the default LED state is on. The LED goes off when the voltage at the input is below [1/3 * V+] volts.
Reed Relay Outputs (SIM8-OUT-RLY10) — OBSOLETE (replaced by SIM8-OUT-SSR and SIM8-OUT-HCR)	
Current rating.....	Maximum of 10 Watts. <ul style="list-style-type: none"> <input type="checkbox"/> Switching voltage to 200 VDC or 200 VAC peak resistive <input type="checkbox"/> Switching current to 0.5A
Operate time, including bounce – typical.....	0.4 milliseconds
Release time – typical.....	0.1 milliseconds
Capacitance – typical.....	0.7 pF
Status.....	Check with the TIO command. LED is on when the relay contact is closed.
Digital Outputs (SIM8-OUT-NPN and SIM8-OUT-PNP)	
Sinking/Sourcing.....	SIM8-OUT-NPN provides 8 sinking outputs. SIM8-OUT-PNP provides 8 sourcing outputs.
Voltage (sinking — SIM8-OUT-NPN)	Output voltage level is less than or equal to 0.4 VDC when sinking up to 50 mA. (\leq 0.4 VDC for 50 mA). Output voltage level is less than or equal to 2.5 VDC when sinking up to 300 mA. (\leq 2.5 VDC for 300 mA).
Voltage (sourcing — SIM8-OUT-PNP)	Output voltage level may be up to 2 volts less than the user-supplied voltage V+ when sourcing up to 50 mA. Output voltage level may be up to 2.5 volts less than the user-supplied voltage V+ when sourcing up to 300 mA.
Current.....	300 mA maximum per output; continuous duty at 50°C ambient temperature. NOTE: For PNP outputs, the actual current is subject to derating, based on load current, duty cycle, and number of simultaneously active outputs (see graph below). Improved performance may be achieved by lowering the ambient temperature and/or staggering the physical order of the outputs that are simultaneously active (for details, refer to page ____).

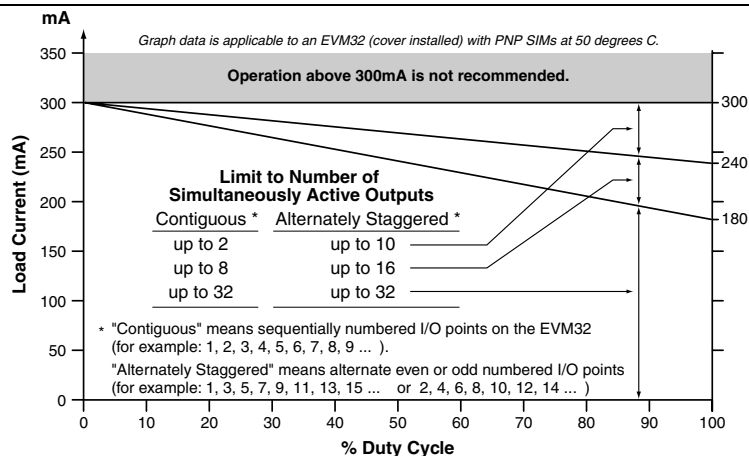

Active level	Set with the <code>OUTLVL</code> command. On power-up or reconnect, SIM8-OUT-NPN is set to active low (<code>OUTLVL0</code>), and SIM8-OUT-PNP is set to active high (<code>OUTLVL1</code>).
Thermal shutdown	Thermal shutdown protects the drive devices from excessive heat. The NPN SIM has 2 drive devices (4 output channels per device); the PNP SIM has 4 drive devices (2 output channels per device). When a drive device reaches 165°C, it will shut down (PNP: shut down two output channels; NPN: shut down four channels). The device driver will again become active when its temperature cools to 150°C.
Short-circuit protection	Digital outputs are short-circuit protected. Short-circuit protection only shuts down the affected output channel. To recover, remove the fault and cycle power to the EVM32.
Status	Check with the <code>TIO</code> command.

Solid State Relay (SIM8-OUT-SSR)

Voltage rating	Maximum of 130V AC/DC.
Current rating	Maximum of 100 mA.
Operate (On) time—Typical	0.1 ms at 50 mA Load, 100V
Release time—Typical	0.11 ms at 50 mA Load, 100V
On-state resistance	24 Ohms (pulsed), 50 ma Load
Off-state resistance	10 ¹⁰ Ohms
Capacitance	6 pF at 50V
Status	Check with the <code>TIO</code> command. LED is on when the relay is energized.
Technology	Power MOSFET Photovoltaic Relay, Single-Pole, Normally Open, Bounce-Free Operation.

High Current Relay (SIM8-OUT-HCR)

Operating voltage range	0 to 60 VDC (or AC Peak).
Voltage rating	Maximum of 130V AC/DC.
Current rating	Maximum of 0.600 Amps.
Operate (On) time—Typical	0.2 ms at 500 mA Load, 50V
Release time—Typical	0.5 ms at 500 mA Load, 50V
On-state resistance	500 mOhms
Off-state resistance	10 ⁸ Ohms
Capacitance	150 pF at 50V
Status	Check with the <code>TIO</code> command. LED is on when the relay is energized.
Technology	Power MOSFET Photovoltaic Relay, Single-Pole, Normally Open, Bounce-Free Operation.

Analog Inputs (SIM8-AN-IN)

Input voltage range	12-bit A/D converter, ±10 VDC; unipolar/bipolar range selectable <code>ANIRNG</code> command. Unipolar: 0V to 10 VDC, or 0V to 5V; Bipolar: -10 to +10V (factory default), or -5V to +5V.
Input current (worst case load)	Unipolar: 720µA @ 0V to 10 VDC range; 360µA @ 0V to 5V range. Bipolar: -1200µA @ -10V and 720µA @ +10V; -600µA @ -5V and 360µA @ +5V.
Input dynamic resistance	Unipolar: 21KΩ; Bipolar: 16KΩ
Fault tolerance	±16.5V
Sample rate	Each input requires 2ms (e.g., 4 ms for 2 inputs, 16ms for 8 inputs); therefore, to maximize performance, you should disable unused inputs with <code>ANIDEN</code> command.
Status	Check with the <code>TIO</code> command.

Analog Outputs (SIM8-AN-OUT)

Output voltage range	10-bit DAC, ±10 VDC, 8 channels total.
Load	2KΩ resistive at 5 mA maximum.
Linearity error	0.66% (typical), 1.3% maximum, over the ±10 VDC range.
Status	Check with the <code>TIO</code> command or the <code>TANO</code> command.

EVM32 Dimensions

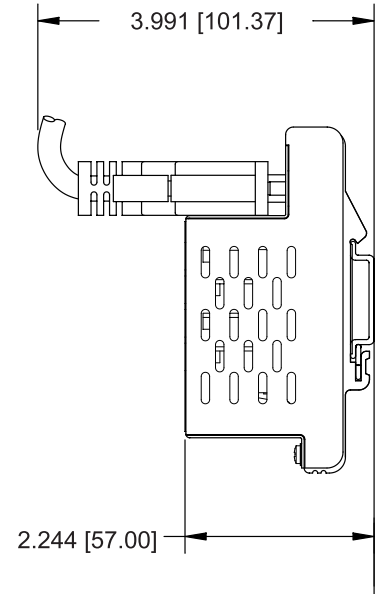
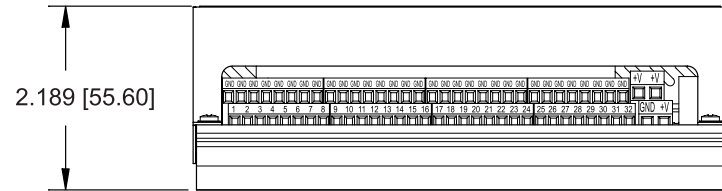
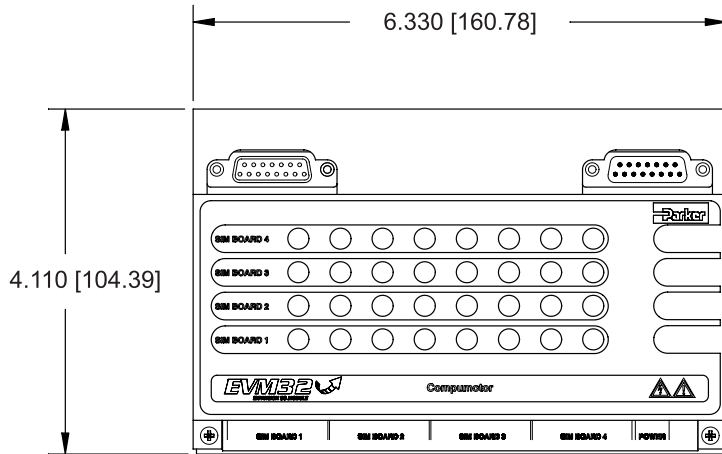

EVM32-II Dimensions

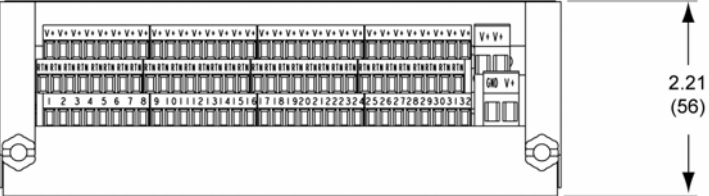
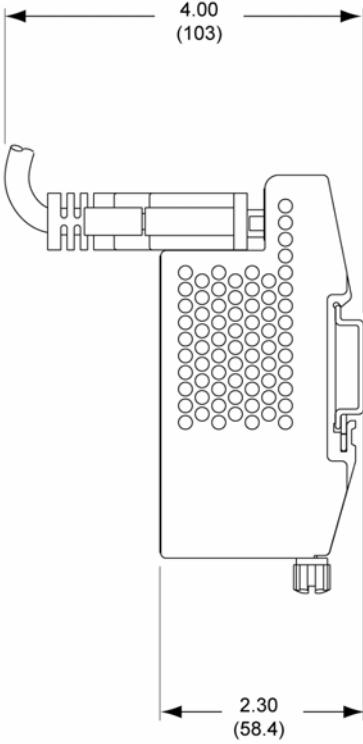
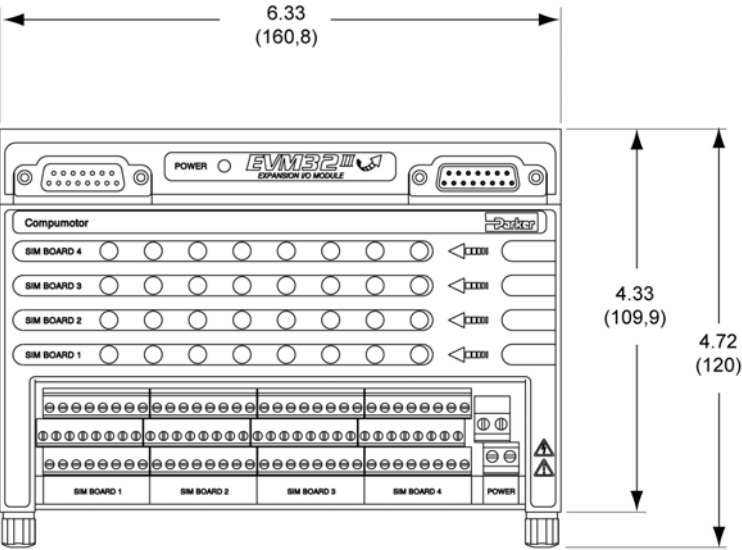

Installing the SIM Boards

Step 1: Remove the Cover



Caution — EVM32 SIM boards are static sensitive. Observe proper ESD handling precautions.
Remove power to the EVM32 baseboard before installing or removing the SIM boards.

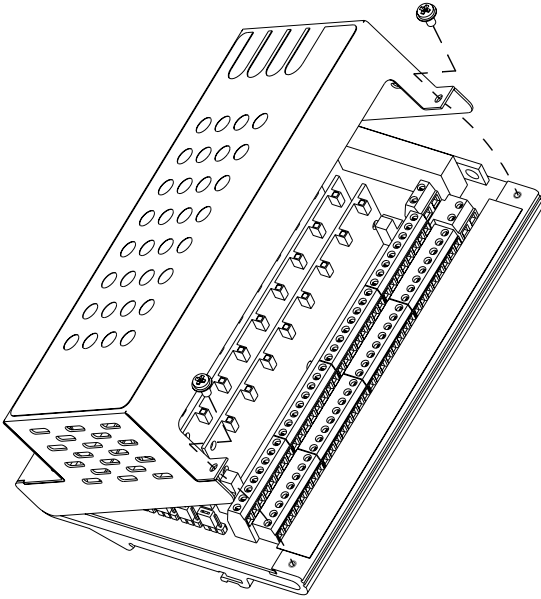

Step 2: Install the SIM boards

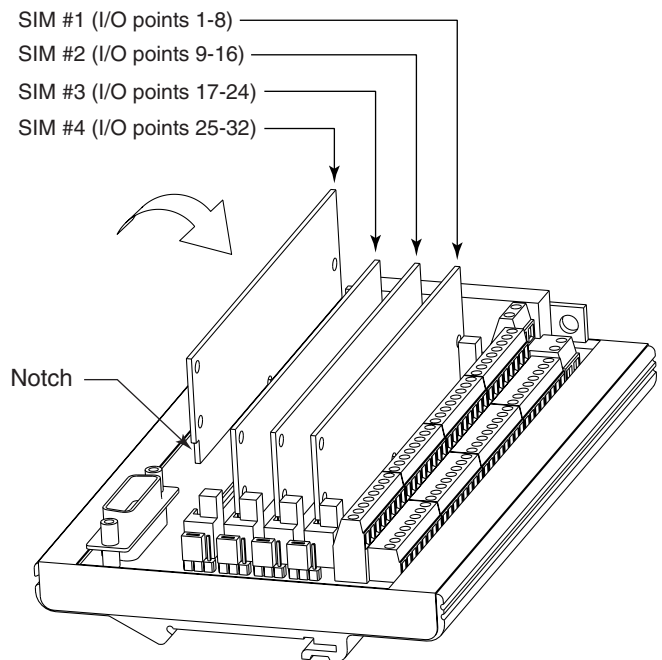
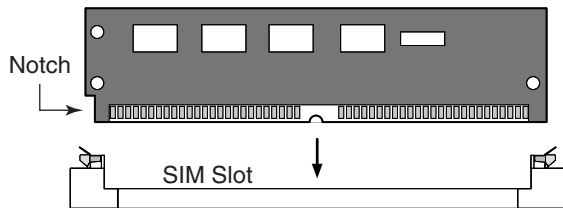
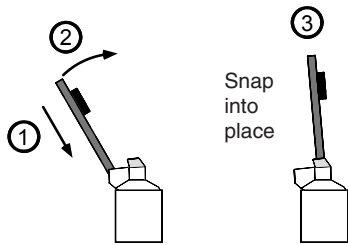

Step 3: (SIM8-IN-EVM32 only) Set the jumpers to select sinking or sourcing

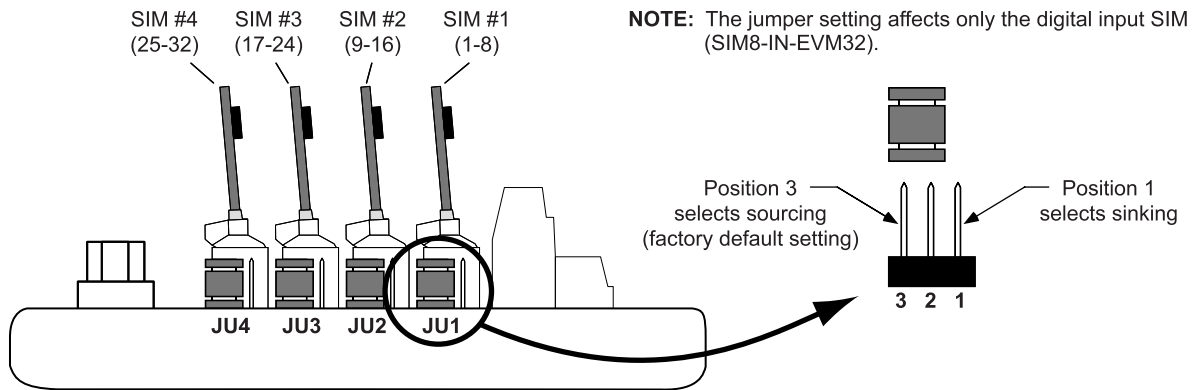

Step 4: Replace the cover and label the SIM locations

SIM Board	Color	Label
SIM8-IN-EVM32 (digital inputs)	Red	8 IN
SIM8-OUT-NPN (digital outputs, sinking)	Blue	8 OUT (NPN)
SIM8-OUT-PNP (digital outputs, sourcing)	Blue	8 OUT (PNP)
SIM8-OUT-RLY10 (reed relay outputs)	Blue	RELAY
SIM8-OUT-SSR (Solid State Relay)	Blue	RELAY
SIM8-OUT-HCR (High Current Relay)	Blue	RELAY
SIM8-AN-IN (analog inputs)	Green	ANALOG IN
SIM8-AN-OUT (analog outputs)	Black	ANALOG OUT

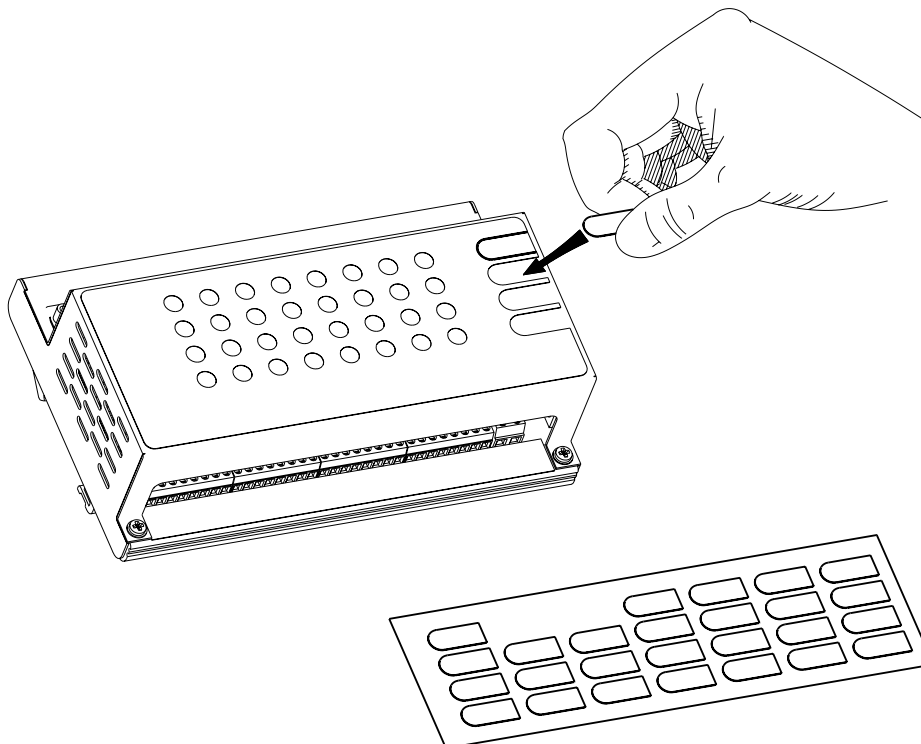

Electrical Connections



Caution — Remove power to the 6K controller and the EMV32 baseboard before:

Installing or removing SIM boards on the EVM32 baseboard
Connecting or disconnecting the EVM32 baseboard to the 6K controller or to other EVM32 units.
Connecting inputs and outputs to the EVM32.

Connecting the 6K controller and EVM32 I/O bricks

If the EVM32 I/O brick is disconnected (or if it loses power), the 6K will perform a kill (all motion and program execution on all tasks) and set error bit #18 (reported with the `TER`, `TERF` and `ER` commands). The 6K will remember the brick configuration (volatile memory) in effect at the time the disconnection occurred. When you reconnect the I/O brick, the controller checks to see if anything changed (SIM by SIM) from the state when it was disconnected. If an existing SIM slot is changed (different SIM, vacant SIM slot, or jumper setting), the controller will set the digital input SIMs and digital output SIMs to factory default `INEN` and `OUTLVL` settings, respectively. If a new SIM is installed where there was none before, the new SIM is auto-configured to factory defaults.

When the 6K powers up and detects a digital output SIM on a EVM32, it will set the active level (`OUTLVL` command) according to the type of SIM. `OUTLVL0`, active low, is selected for NPN SIMs; `OUTLVL1`, active high, is selected for PNP SIMs.

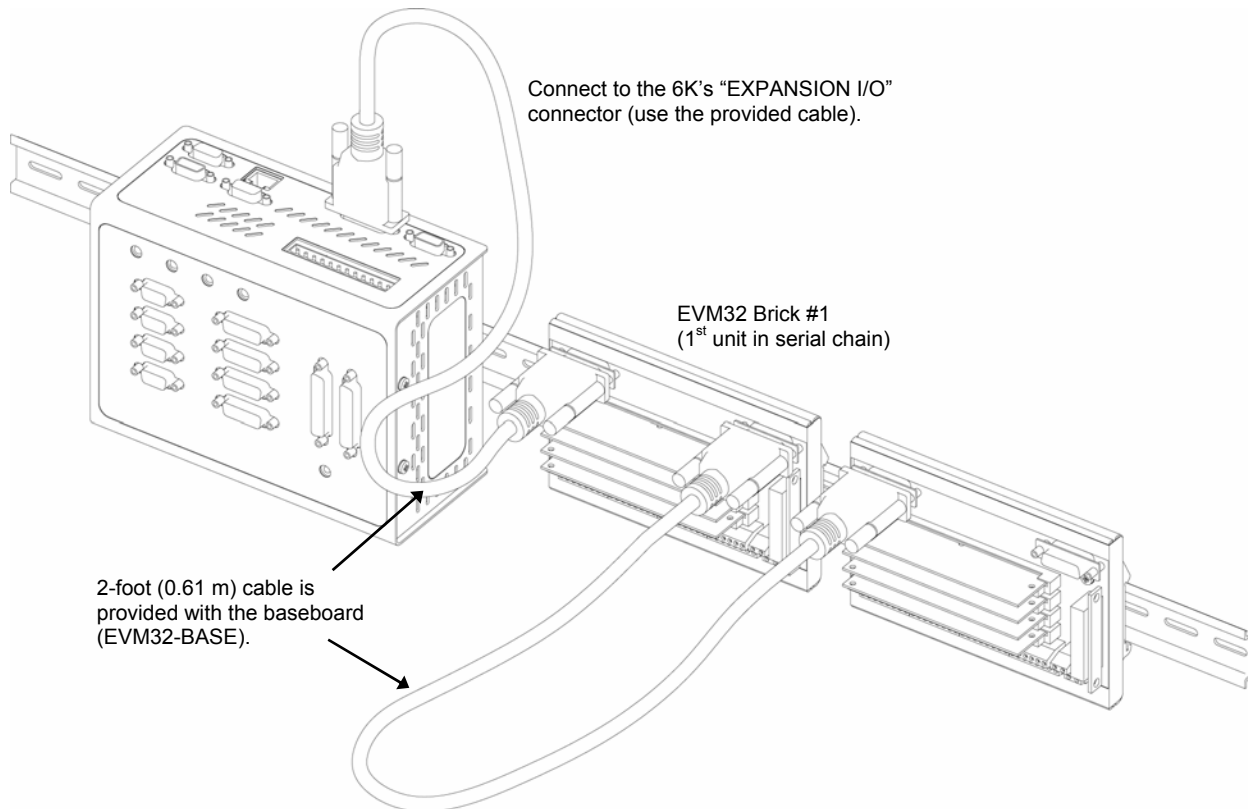

To check the status of one or more EVM32 I/O bricks, use the `TIO` command.

Jumpers

The EVM32-1I includes jumpers for terminating the DATA and ATTN lines on the last I/O brick in a chain. The following equivalent diagram applies to JU5 and JU6.

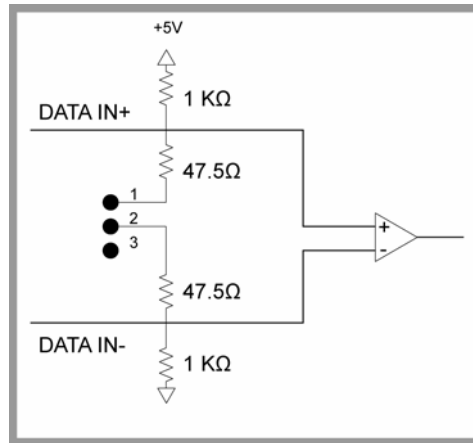

24 VDC power input

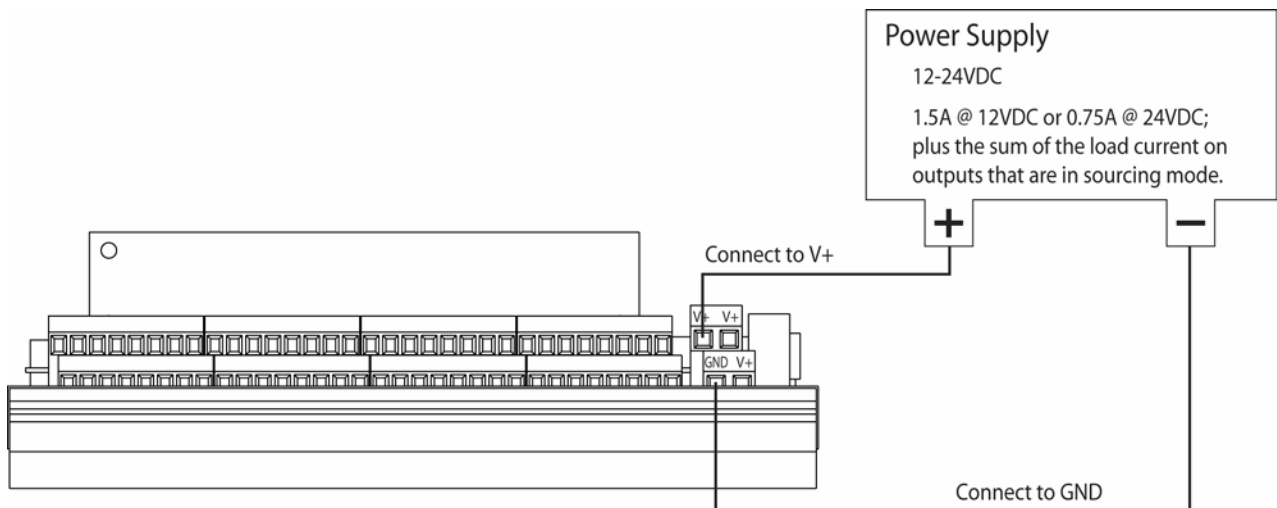

Reed Relay Outputs (SIM8-OUT-RLY10)

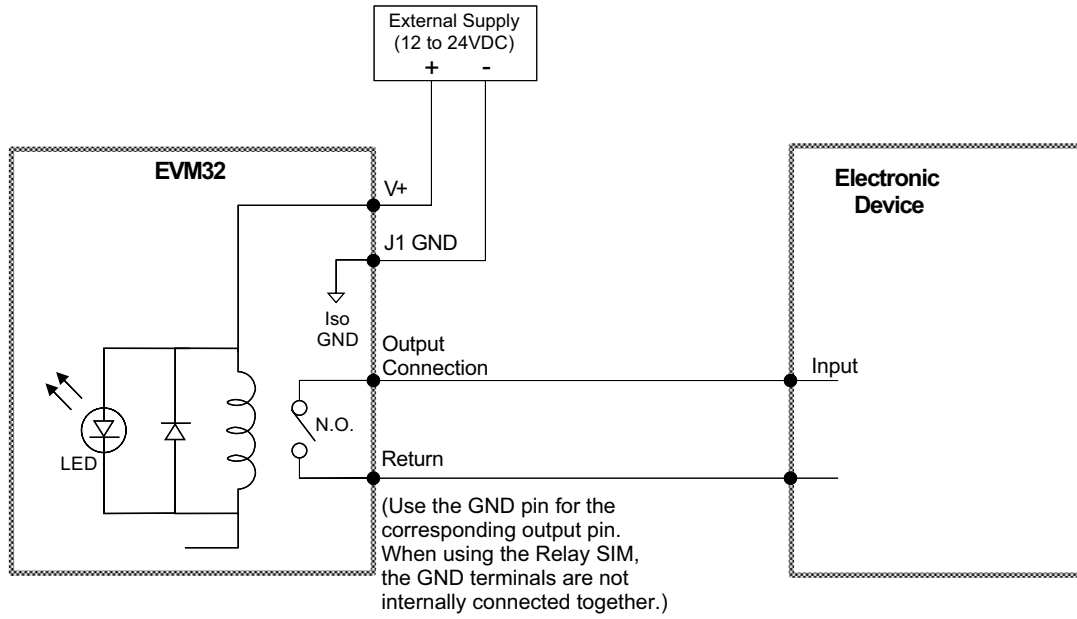

Digital Inputs (SIM8-IN-EVM32)

Sinking

(connecting to a sourcing output)

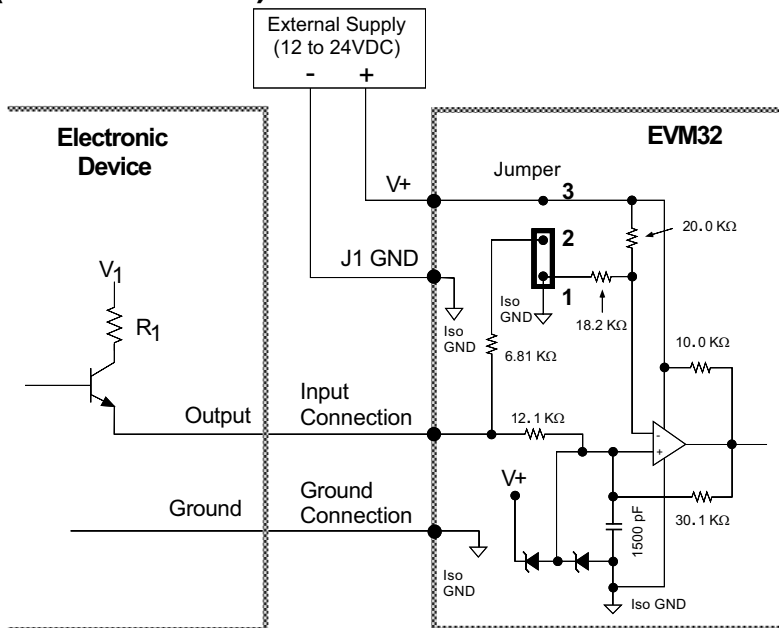

Sourcing

(connecting to a sinking output)

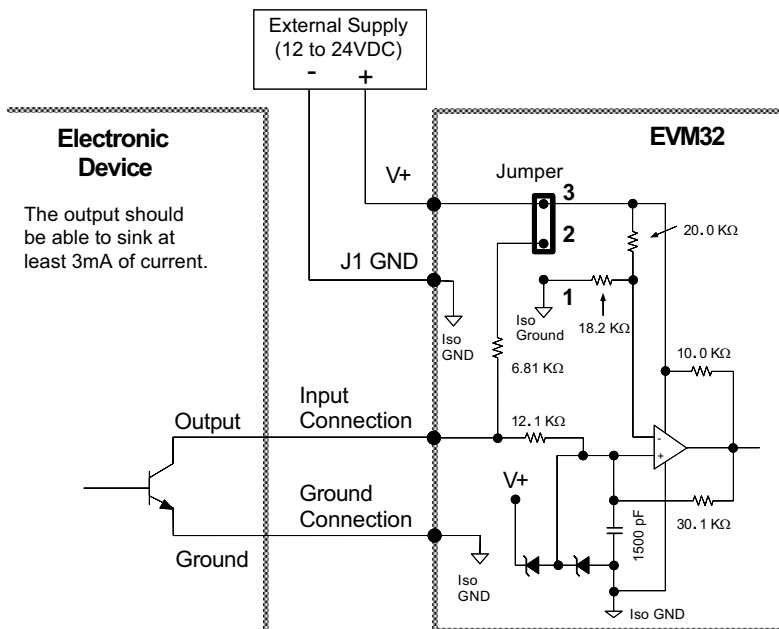

The output should be able to sink at least 3mA of current.

Interrelationships

Active Level *	Jumper Selection *	Switch	Voltage at Input	LED	IN/TIN/TIO Report
INLVL0 (active low)	Position 3 (sourcing)	Open	$\geq 2/3$ of V+	On	0
INLVL0 (active low)	Position 3 (sourcing)	Closed	$< 1/3$ of V+	Off	1
INLVL1 (active high)	Position 3 (sourcing)	Open	$\geq 2/3$ of V+	On	1
INLVL1 (active high)	Position 3 (sourcing)	Closed	$< 1/3$ of V+	Off	0
INLVL0 (active low)	Position 1 (sinking)	Open	$< 1/3$ of V+	Off	1
INLVL0 (active low)	Position 1 (sinking)	Closed	$\geq 2/3$ of V+	On	0
INLVL1 (active high)	Position 1 (sinking)	Open	$< 1/3$ of V+	Off	0
INLVL1 (active high)	Position 1 (sinking)	Closed	$\geq 2/3$ of V+	On	1

* Factory default: INLVL0 (active low) and jumper in position 3 (sourcing). Jumper location is illustrated on page 51.

Digital Outputs (SIM8-OUT-NPN and SIM8-OUT-PNP)

SIM8-OUT-NPN

(sinking outputs)

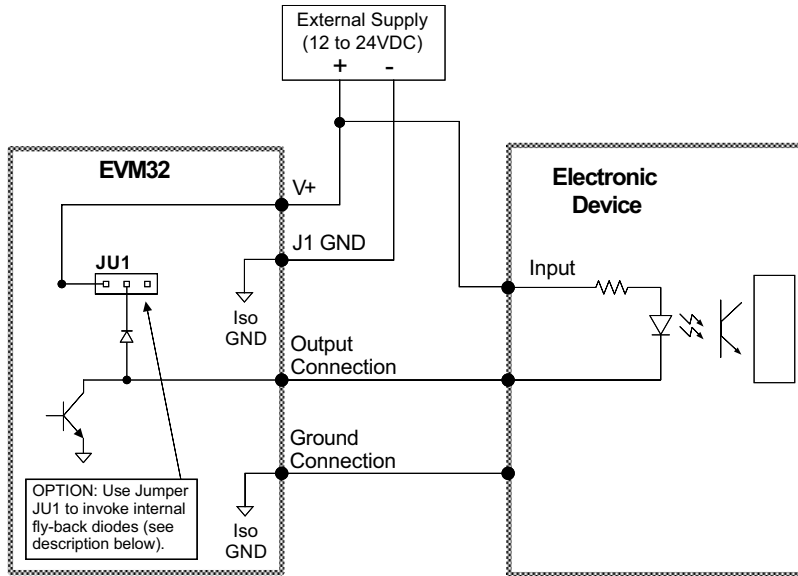

Fly-Back Diodes: The SIM card is sent from the factory with jumper JU1 in the “no connect” position (fly-back diodes not used). If you move the jumper to the left-hand position, eight fly-back diodes are invoked, one for each of the 8 output channels.

Caution: If the power supply voltage for the remote device (to which the outputs are connected) is greater than the power supply voltage for the EVM32, do not use the fly-back diodes.

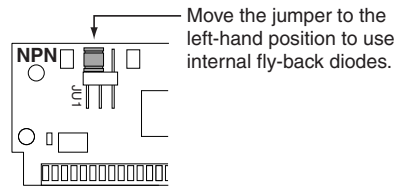
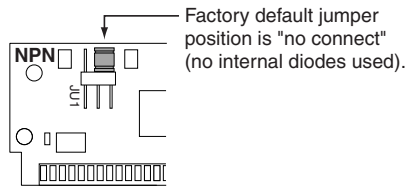

External Diodes: Use an external diode when driving inductive loads (you can do this only if you have not invoked the fly-back diodes with jumper JU1). Connect the diode in parallel to the inductive load.

SIM8-OUT-PNP

(sourcing outputs)

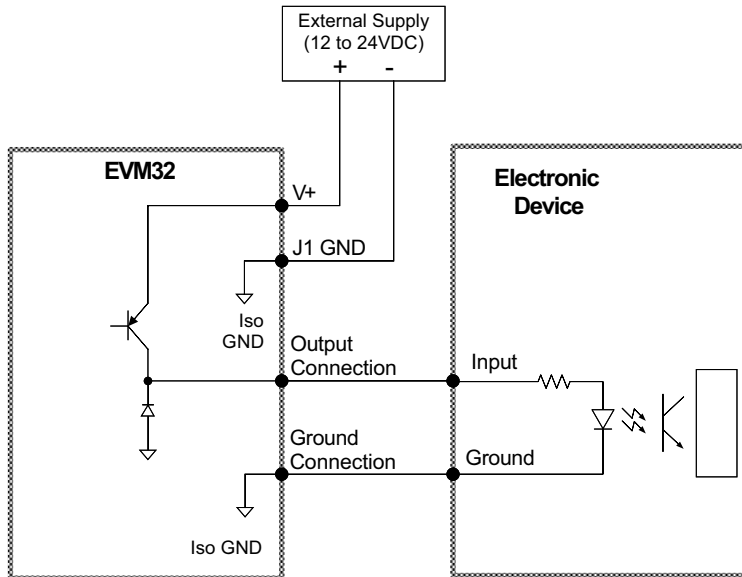

Solid State Relay Outputs (SIM8-OUT-SSR)

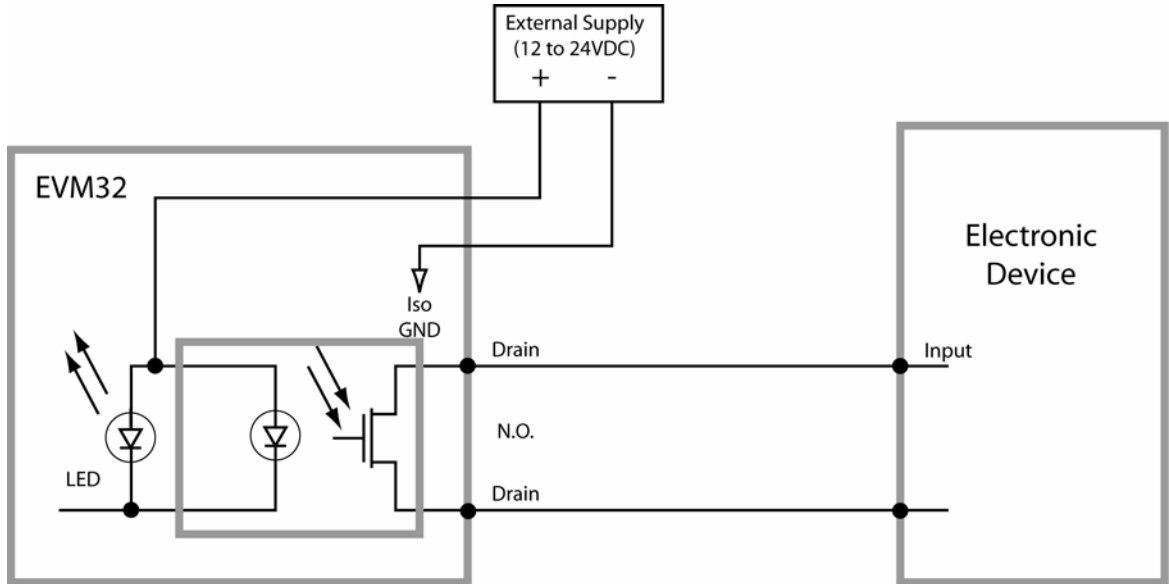

(Use the GND pin for the corresponding output pin.
When using the SIM, the GND terminals are not internally connected together.)

High Current Relay Outputs (SIM8-OUT-HCR)

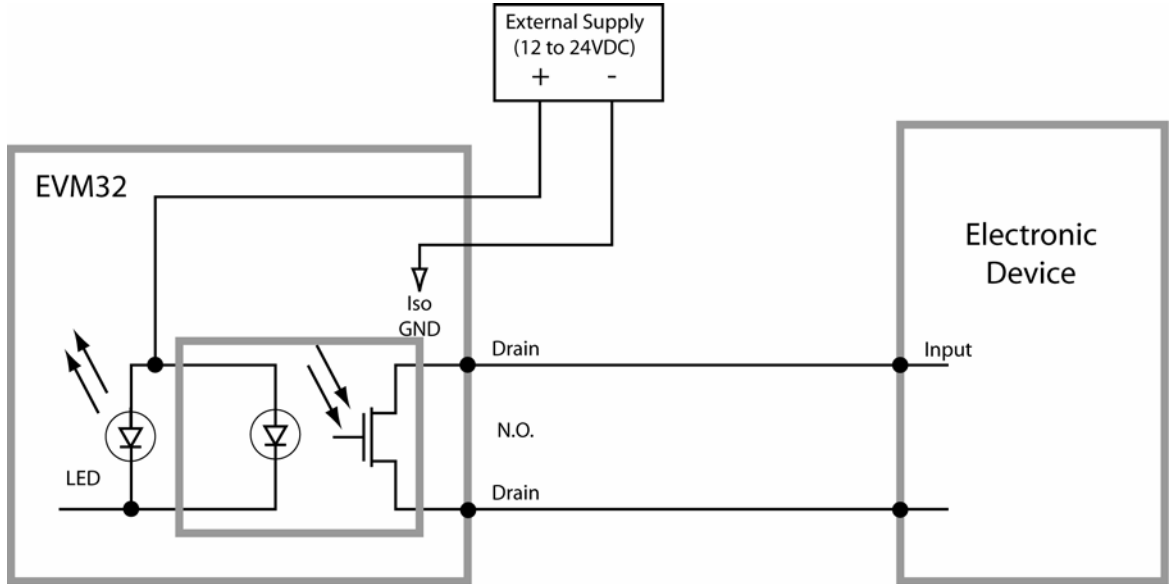

(Use the GND pin for the corresponding output pin.
When using the SIM, the GND terminals are not internally connected together.)

Analog Inputs (SIM8-AN-IN)

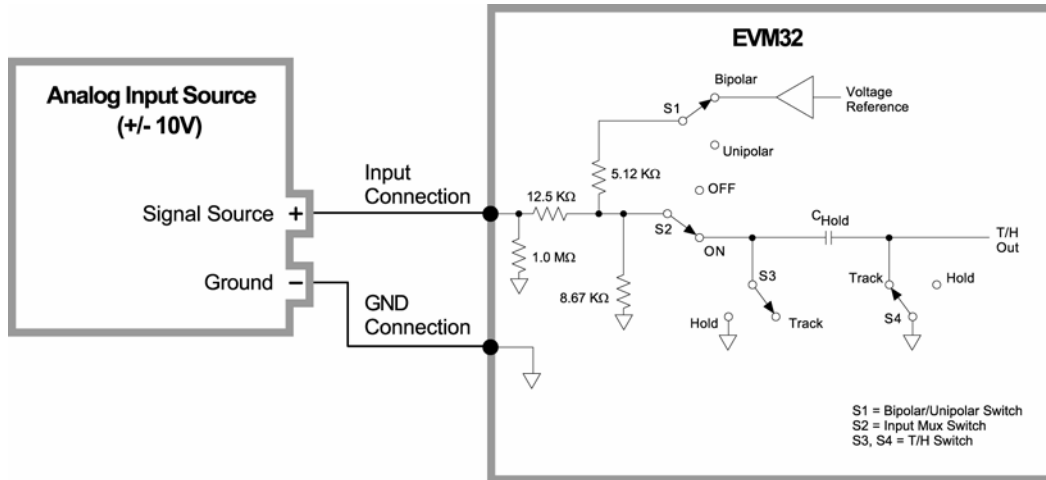

Analog Outputs (SIM8-AN-OUT)

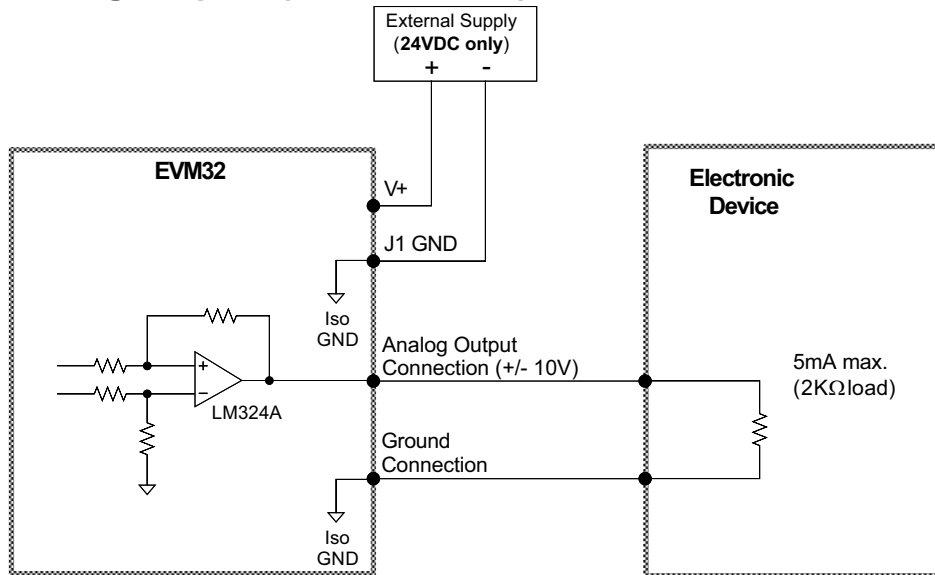

Appendix C. Servo Tuning

The tuning process is a subset of the controller setup process that Motion Planner helps you with in the Editor.

To assure optimum performance you should tune your servo system. The goal of the tuning process is to define the gain settings, servo performance, and feedback setup (see command list below) that you can incorporate into your application program. (Typically, these commands are placed into a setup program). Servo tuning should be performed as part of the application *setup process*, as described below.

To tune your servo system

To assure optimum performance you should tune your servo system. The goal of the tuning process is to define the gain settings, servo performance, and feedback setup (see command list below) that you can incorporate into your application program. (Typically, these commands are placed into a setup program). Servo tuning should be performed as part of the application *setup process*, as described below

1. After you launch Motion Planner, you will see the Editor window. Click on the "Tuner" window tab to bring the servo tuning utility to the front.
2. Click the "Start" button to send the pre-programmed step output to the drive. Notice that the graph display draws the commanded and actual velocity profiles so that you can graphically tune your servo system.

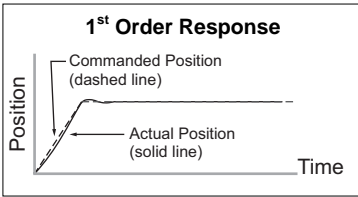

Optimize the proportional (SGP) and velocity (SGV) values by iteratively changing gains and viewing the results on the graph display. The object is to achieve a 1st order response (minimal overshoot and close position tracking). The typical process is illustrated in the flow diagram on the next page.

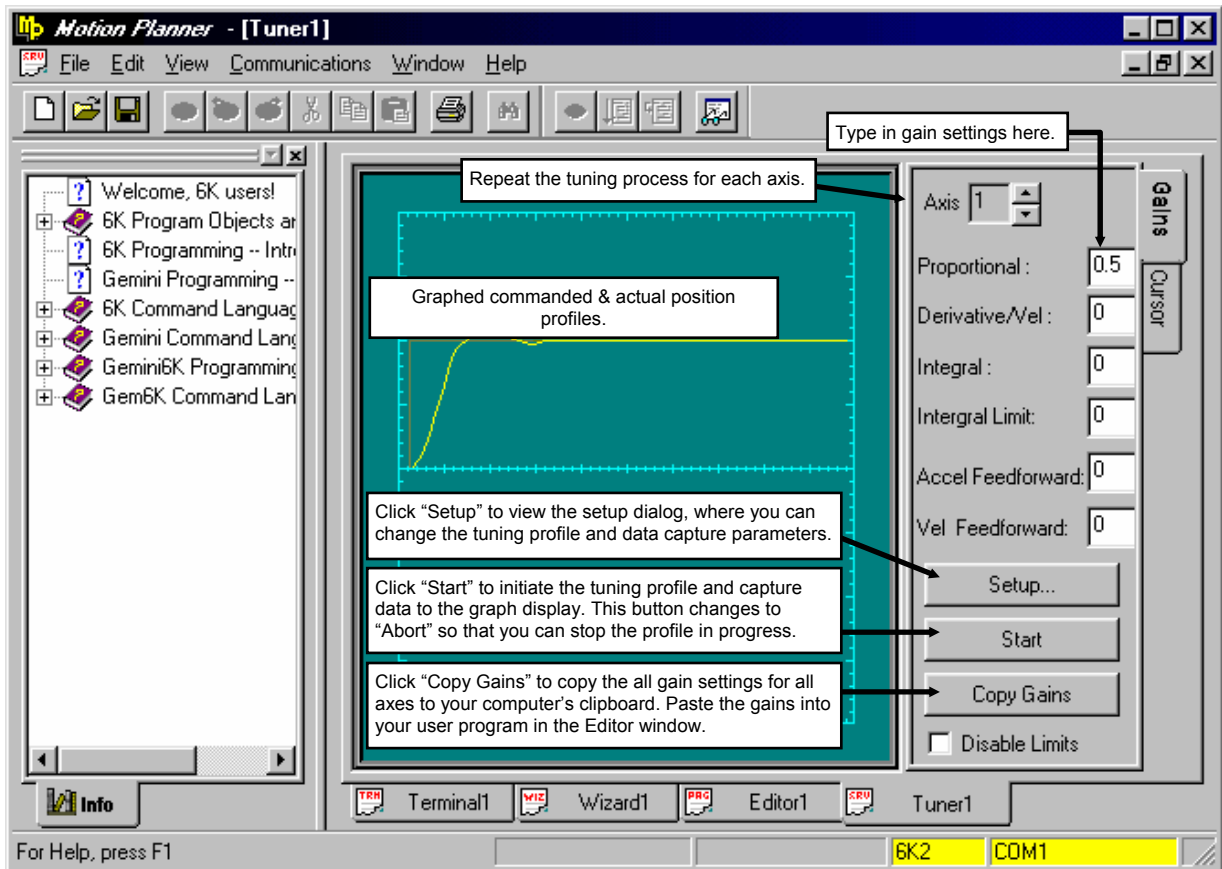

Basic Tuning Process

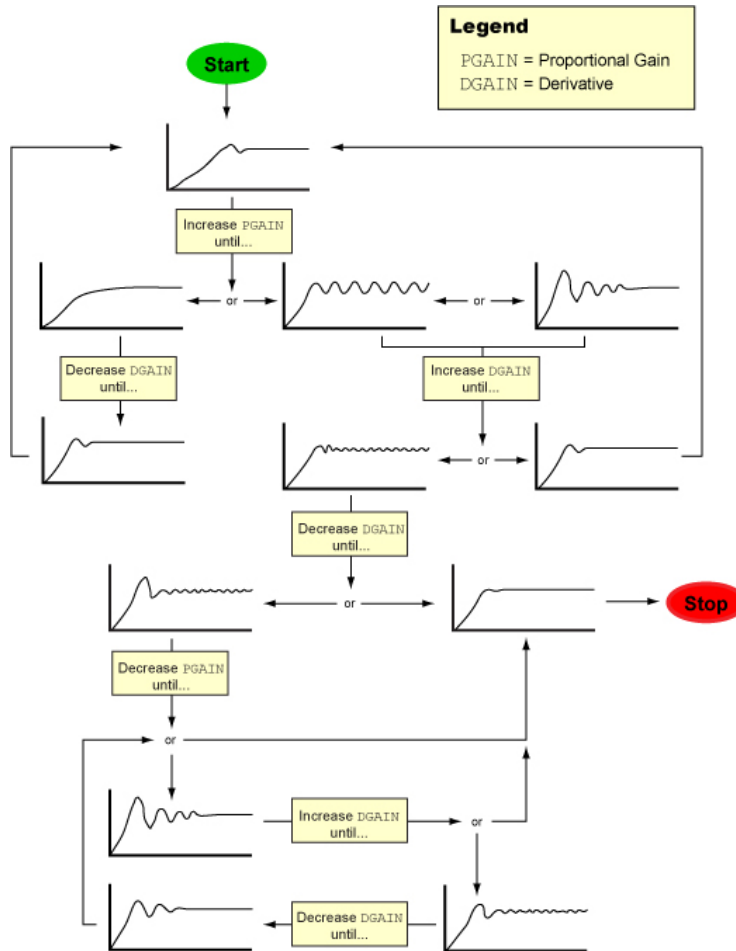

3. Repeat step 2 for each axis.
4. When you have determined which tuning gains are best for your application's performance, insert the gain commands into your setup program (see illustration below):
 - a. Click the "Copy Gains" to Clipboard button. This copies the gain commands to your computer's clipboard.
 - b. Click the "Editor" tab to bring the program editor to the front.
 - c. Place the cursor at the location in your program where you wish to insert the gain commands (see note below).
 - d. Paste the gain commands at the location of the cursor. Use the <ctrl>V keystroke shortcut or use the "Paste" command from the "Edit" pull-down menu.

NOTE: The tuning gains are specific to the feedback source selection in effect at the time the gain commands are executed. The factory default feedback source (selected with the *SFB* command) is encoder feedback. The illustration below demonstrates where to insert the gain commands relative to the *SFB* command.

If your application requires you to switch between feedback sources for the same axis, then for each feedback source you must select the source with the *SFB* command and then execute the tuning gain commands relevant to the feedback source (an example is provided in the illustration below).

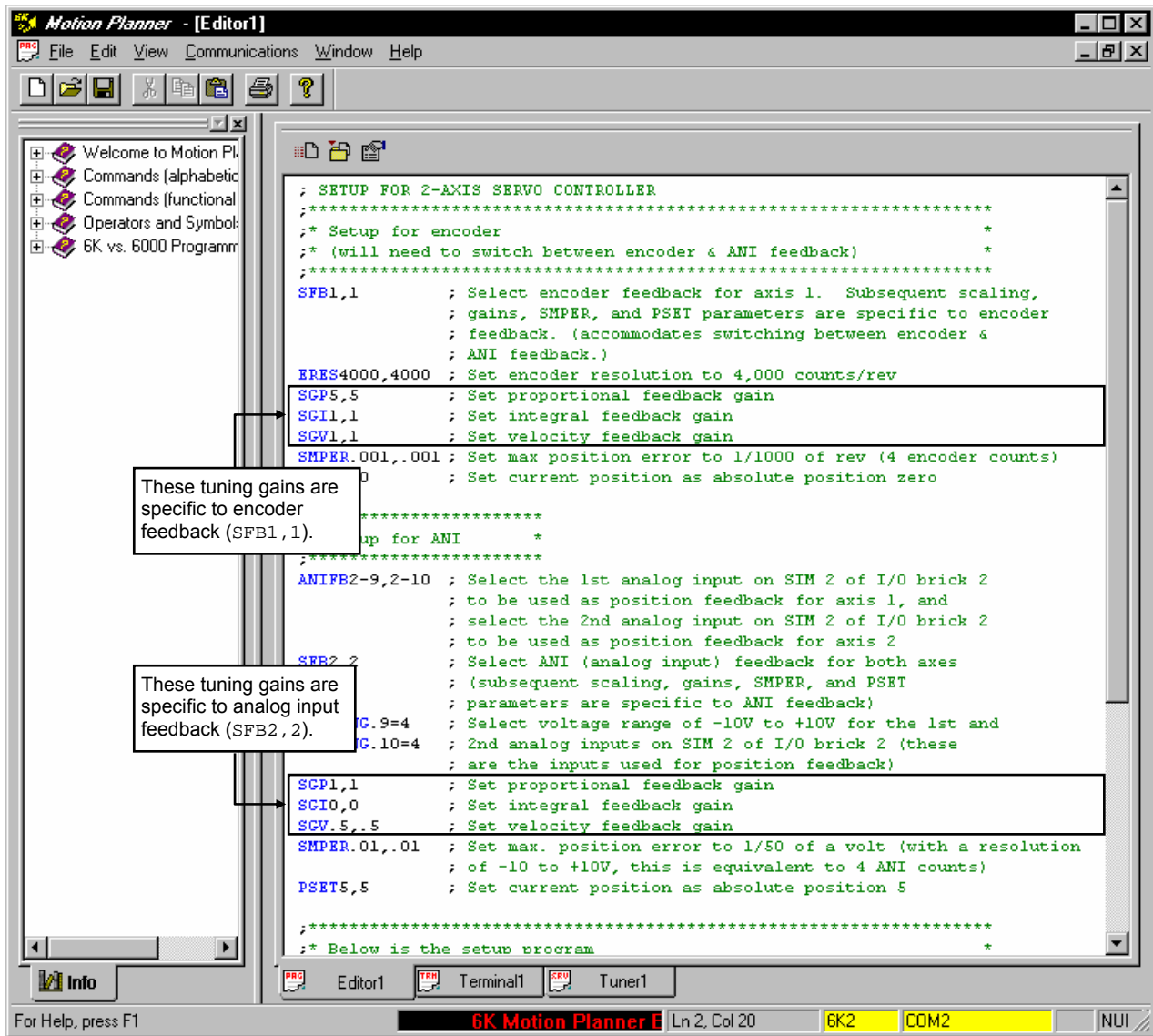

Tuning-Related Commands

(See *6K Series Command Reference* for details)

Tuning Gains

SGP Sets the proportional gain in the PIV&F servo algorithm.

SGI Sets the integral gain in the PIV&F servo algorithm.

SGV Sets the velocity gain in the PIV&F servo algorithm.

SGAF Sets the acceleration feedforward gain in the PIV&F_a algorithm.

SGVF Sets the velocity feedforward gain in the PIV&F_v algorithm.

SGILIM .. Sets a limit on the correctional control signal that results from the integral gain action trying to compensate for a position error that persists too long.

SGENB Enables a previously-saved set of PIV&F gains. A set of gains (specific to the current feedback source selected with the **SFB** command) is saved using the **SGSET** command.

SGSET Saves the presently-defined set of PIV&F gains as a gain set (specific to the current feedback source on each axis). Up to 5 gain sets can be saved and enabled at any point in a move profile, allowing different gains at different points in the profile.

Feedback Setup

SFB Selects the servo feedback device (encoder or analog input). To use analog input feedback, you must first use the **ANIFB** command to configure the targeted analog input to be used for feedback.

Important: Parameters for scaling, tuning gains, max. position error (**SMPER**), and position offset (**PSET**) are specific to the feedback device selected (with the **SFB** command) at the time the parameters are entered (see programming examples in *Programmer's Guide*).

ERES Encoder resolution.

SMPER Sets the maximum allowable error between the commanded position and the actual position as measured by the feedback device. If the error exceeds this limit, the controller activates the Shutdown output and sets the DAC output to zero (plus any **SOFFS** offset). If there is no offset, the motor will freewheel to a stop. You can enable the **ERROR** command to continually check for this error condition (**ERROR.12-1**), and when it occurs to branch to a programmed response defined in the **ERRORP** program.

Index

24 VDC power	
6K33	
EVM32	55
2-wire RS-485	
connections	31
DIP switch settings	5
4-wire RS-485	
connections	30
DIP switch settings	5
accessories, orderable	3
active level	
inputs	26
outputs	27
address	
Ethernet, IP	29
RS-232	29
RS-485	30
analog inputs on EVM32	47, 60
analog outputs on EVM32	60
Apex drive connections	11
Aries drive connections	12
step & direction	18
axis LED	41
baud rate, RS-232	29
BD-E drive connections	12
brackets, mounting option	7
change summary	iv
communication interface	28
Ethernet	29
RS-232	29
RS-485	30
serial communication problems	43
Compax3 drive connections	
servo	13
step & direction	19
connections	8
analog inputs (EVM32)	60
analog outputs (EVM32)	60
communication	28
digital inputs (EVM32)	57
digital outputs (EVM32)	58
enable input	9
end-of-travel limits	24
Ethernet	29
EVM32	54
high current relay outputs (EVM32)	59
home limits	24
installation test procedures	34
onboard outputs	25, 27
onboard triggers	25, 26
reed relay outputs (EVM32)	56
RP240	32
RS-232	29
RS-485	30
servo (+/- 10V) drives	10
solid state relay outputs (EVM32)	59
step & direction drives	17
contaminants and liquids	7
crossover cable	29
daisy-chain, RS-232	29
digital inputs on EVM32	47, 57
digital outputs on EVM32	47, 58
dimensions	
6K6	
DIN rail mount	7
diode for outputs	27
drive connections	
servo (+/- 10V)	10
step & direction	17
drive fault input	11, 18
Dynaserv drive connections	
servo	13
step & direction	19
Dynaserv GE drive connections	
servo	14
step & direction	20
EAC drive connections	20
EDC drive connections	20
electrical connections	See connections
electrical noise guidelines	2
enable input	9
encoder	
resolution	40
end-of-travel limit inputs, connections	24
environmental specifications, 6K	7
estop switch	9
Ethernet connections	29
EVM32	47
expansion I/O	47
general specifications	4
help	38
high current relay outputs on EVM32	59
home limit inputs, connections	24
humidity	7
inputs	
24 VDC power input to 6K	33
analog inputs on EVM32	60
digital inputs on EVM32	57
drive fault	11, 18
enable	9
end-of-travel limits	24
expansion I/O	47
home limit	24
installation test	34
triggers	25, 26
VM25 connections	45
installation test procedures	34
installing SIM boards, EVM32	52
internal schematics	See connections
IP address	29
jumpers, sinking & sourcing (EVM32)	53
LEDs	41
Linearserv drive connections	
servo	14
step & direction	21
maximum position error, establishing limit	64
mounting	7
multi-drop, RS-485	30
noise, electrical, guidelines	2
OEM670SD drive connections	21
OEM670T & OEM675T drive connections	15
OEM750 drive connections	20
onboard programmable I/O connections	25
optional accessories	3

output diode	25, 27	screw-terminal adapter	45
outputs		servo tuning	61
analog outputs on EVM32	60	ship kit	3
digital outputs on EVM32	58	EVM32	47
high current relay outputs on EVM32	59	SIM boards, EVM32	47
onboard	25, 27	SIM8-AN-IN	47
reed relay outputs on EVM32	56	SIM8-IN	47
solid state relay outputs on EVM32	59	SIM8-OUT-EVM32	47
VM25 connections	45	sizing your power supply, 6K	33
part numbers	3	solid state relay outputs on EVM32	59
PDS drive connections	20	solutions to common problems	39
performance specifications	4	specifications	
PKH130M drive connections	21	environmental (6K)	7
position		EVM32	48
error, max. allowable	64	general	4
power input		straight-through cable	29
6K33		status LEDs	41
EVM32	55	SV drive connections	15
power LED	41	technical support	38
precautions	2, 5, 34, 52, 54	temperature specification	7
product return procedure	44	testing I/O installation	34
recommended installation process	2	TQ10 drive connections	16
reed relay outputs on EVM32	56	trigger input connections	25, 26
related publications	ii	troubleshooting	37
relay outputs on EVM32	56	methods	38
return procedure	44	resolving serial communication problems	43
RP240 connections	32	solutions to common problems	39
RS-232 connections	29	tuning, servo	61
RS-485		Vix drive connections	
connections	30	servo	16
DIP switches, accessing & setting	5	step & direction	22
S drive connections	20	VM25 25-pin screw-terminal adapter	45
safety stop switch (enable input)	9	Zeta drive connections	20
schematics, internal	See connections		