

Products Available From



Solid State Relays and I/O Modules
Catalog 1



Automation Controls
Catalog 2



Switches and Sensors
Catalog 3



Motors and Fans
Catalog 4



Pneumatics
Catalog 5

For your copy of the catalogs, contact





















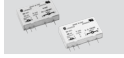

Tel: (800) 677-5311 / Fax: (800) 677-3865
www.crouzet-usa.com

Products and specifications subject to change without notice.

Order/Technical Support – Tel: (800) 677-5311 / FAX: (800) 677-3865 / www.crouzet-usa.com

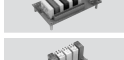
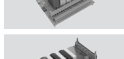

1) Solid State Relays and Digital I/O Modules

Solid State Relays & Heat Sinks	1/1
 GN & GNA5 Series AC Output Solid State Relays	1/2
 SSR Monitoring Module	1/6
 GF & GT Series DC Output Solid State Relays	1/8
 Dual Output Solid State Relays	1/9
 GA8 & GA1 Series PC Mount Solid State Relays	1/10
 GA3 Series Three-Phase Solid State Relays	1/12
 GA0 Motor-Reversing Solid State Relays	1/14
 GZ Series Solid State Relays	1/16
 SIMM Series Relays	1/18
 RHP Series Hybrid Relays	1/21
 DIN Rail Solid State Relays	1/22
 Heat Sinks and Accessories	1/29
 Digital I/O Modules & Mounting Boards	 1/38
 0.6" Series Input / Output Modules	1/38
 M Series Input / Output Modules	1/42
 Quad Input / Output Modules	1/46
 SM Series Input / Output Modules	1/50
 "Universal Logic" Modules	1/54
 Reed Relay Output Modules	1/56
 C4 Series Input / Output Modules	1/58
 DIN Rail Mount Input / Output Modules	1/64
 0.6" Series I/O Mounting Boards	1/70
 M Series I/O Mounting Boards	1/80
 Quad I/O Mounting Boards	1/85
 SM Series I/O Mounting Boards	1/91
 C4 Series I/O Mounting Boards	1/96
Mounting Board Accessories	1/97

Products and specifications subject to change without notice.

Order/Technical Support – Tel: (800) 677-5311 / FAX: (800) 677-3865 / www.crouzet-usa.com

Index

Part Number	Page	Part Number	Page	Part Number	Page	Part Number	Page	Part Number	Page
84060001	1/6	84134340	1/2	84145020	1/19	IAC24A	1/39	PB16H	1/75
84115501	1/68	84134380	1/2	84145021	1/19	IAC5	1/39	PB16HQ	1/86
84115502	1/68	84134750	1/8	84145024	1/19	IAC5A	1/39	PB16M	1/81
84115503	1/68	84134850	1/8	84145025	1/19	IAC5AQ	1/47	PB16MC	1/81
84130100	1/23	84134860	1/8	84145031	1/19	IAC5EQ	1/47	PB16MV	1/81
84130101	1/23	84134870	1/8	84145041	1/20	IAC5Q	1/47	PB16Q	1/85
84130102	1/23	84134900	1/3	84145042	1/20	IDC24	1/39	PB16S	1/76
84130103	1/23	84134901	1/3	84145043	1/20	IDC24F	1/39	PB16SM	1/92
84130104	1/69	84134902	1/3	84145046	1/20	IDC24N	1/39	PB16SMA	1/92
84130105	1/69	84134904	1/3	84145050	1/20	IDC5	1/39	PB16SMB	1/92
84130108	1/69	84134905	1/3	84145051	1/20	IDC5BQ	1/47	PB16SMC	1/92
84130110	1/25	84134907	1/3	84145052	1/20	IDC5F	1/39	PB16SMV	1/92
84130111	1/25	84134909	1/3	84145053	1/20	IDC5N	1/39	PB16T	1/77
84130112	1/25	84134910	1/3	84145061	1/18	IDC5Q	1/47	PB16V	1/74
84130113	1/25	84134911	1/3	84145062	1/18	JC48	1/103	PB24	1/78
84130114	1/25	84134912	1/3	84145064	1/18	JM2	1/103	PB24C	1/78
84130115	1/25	84134914	1/3	84145066	1/18	JM8	1/103	PB24C4	1/100
84130116	1/23	84134915	1/3	84145071	1/18	JQP2	1/103	PB24HQ	1/88
84130117	1/23	84134917	1/3	11.06.278	1/104	JQP4	1/103	PB24M	1/82
84130118	1/23	84134919	1/3	11.06.288	1/104	JS2	1/103	PB24MD	1/83
84130150	1/23	84136500	1/29	11.06.293	1/104	JS8	1/103	PB24MV	1/82
84130152	1/23	84137000	1/2	11.06.305	1/104	MIAC24	1/43	PB24Q	1/87
84130158	1/23	84137001	1/2	11.06.413	1/105	MIAC24A	1/43	PB24SM	1/94
84130220	1/27	84137010	1/2	11.06.415	1/105	MIAC5	1/43	PB24SMA	1/94
84130221	1/27	84137011	1/2	C4IAC	1/59	MIAC5A	1/43	PB24SMB	1/94
84130222	1/27	84137020	1/2	C4IACA	1/59	MIDC24	1/43	PB24SMC	1/94
84130310	1/27	84137021	1/2	C4IDC	1/59	MIDC5	1/43	PB24SMV	1/94
84130311	1/27	84137030	1/2	C4IDCB	1/59	MIDC5F	1/43	PB24V	1/78
84130312	1/27	84137031	1/2	C4IDCG	1/59	MIDC5N	1/43	PB32C4	1/101
84132000	1/17	84137040	1/2	C4IDCK	1/59	MOAC24	1/45	PB32D	1/79
84132010	1/17	84137041	1/2	C4OAC	1/61	MOAC24A	1/45	PB32HQ	1/90
84132100	1/17	84137080	1/2	C4OACA	1/61	MOAC5	1/45	PB32M	1/84
84132110	1/17	84137081	1/2	C4OACAR	1/61	MOAC5A	1/45	PB32MC	1/84
84132200	1/17	84137100	1/2	C4OACR	1/61	MOAC5AH	1/45	PB32Q	1/89
84132210	1/17	84137101	1/2	C4ODC	1/61	MOAC5AR	1/45	PB32SM	1/95
84132300	1/17	84137110	1/2	C4ODCA	1/61	MOAC5R	1/45	PB4	1/70
84132310	1/17	84137111	1/2	C4SWIN	1/63	MOACU	1/55	PB4C4	1/96
84132400	1/17	84137120	1/2	C4SWOUT	1/63	MOACUA	1/55	PB4H	1/71
84132410	1/17	84137121	1/2	DRIAC24	1/65	MOACUAH	1/55	PB4R	1/70
84132500	1/17	84137130	1/2	DRIAC24A	1/65	MODC24	1/45	PB8	1/72
84132510	1/17	84137131	1/2	DRIAC5	1/65	MODC5	1/45	PB8C4	1/97
84132600	1/17	84137140	1/2	DRIAC5A	1/65	MODC5A	1/45	PB8H	1/73
84132610	1/17	84137141	1/2	DRIDC24	1/65	MODC5F	1/45	PB8M	1/80
84132700	1/17	84137180	1/2	DRIDC24A	1/65	MODC5MA	1/45	PB8MC	1/80
84132710	1/17	84137181	1/2	DRIDC5	1/65	MODC5MC	1/45	PB8MV	1/80
84134000	1/2	84137200	1/2	DRIDC5A	1/65	MODC5ML	1/45	PB8SM	1/91
84134001	1/2	84137210	1/2	DROAC	1/67	MORR24	1/57	PB8SMB	1/91
84134010	1/2	84137220	1/2	DRODC24	1/67	MORR5	1/57	PB8SMC	1/91
84134011	1/2	84137230	1/2	DRODC5	1/67	OAC24	1/41	PB8SMV	1/91
84134020	1/2	84137240	1/2	GA012D25	1/15	OAC24A	1/41	PB8V	1/72
84134021	1/2	84137280	1/2	GA012D40	1/15	OAC5	1/41	SMIAC24	1/51
84134030	1/2	84137300	1/2	GA16B02	1/11	OAC5A	1/41	SMIAC24A	1/51
84134031	1/2	84137310	1/2	GA312A25R	1/13	OAC5AH	1/41	SMIAC5	1/51
84134040	1/2	84137320	1/2	GA312A25Z	1/13	OAC5AQ	1/49	SMIAC5A	1/51
84134041	1/2	84137330	1/2	GA312A45R	1/13	OAC5AR	1/41	SMIDC24	1/51
84134080	1/2	84137340	1/2	GA312A45Z	1/13	OAC5Q	1/49	SMIDC5	1/51
84134081	1/2	84137380	1/2	GA312D10R	1/13	OAC5R	1/41	SMIDC5F	1/51
84134100	1/2	84137750	1/8	GA312D10Z	1/13	OACU	1/55	SMIDC5N	1/51
84134101	1/2	84137850	1/8	GA312D25R	1/13	OACUA	1/55	SMOAC24	1/53
84134110	1/2	84137860	1/8	GA312D25Z	1/13	OACUAH	1/55	SMOAC24A	1/53
84134111	1/2	84137870	1/8	GA312D45R	1/13	ODC15	1/41	SMOAC5	1/53
84134120	1/2	84138000	1/21	GA312D45Z	1/13	ODC24	1/41	SMOAC5A	1/53
84134121	1/2	84138001	1/21	GA86B02	1/11	ODC24A	1/41	SMOAC5AH	1/53
84134130	1/2	84138101	1/21	GA86B02R	1/11	ODC24F	1/41	SMOAC5AR	1/53
84134131	1/2	84138201	1/21	GA86D05	1/11	ODC5	1/41	SMOAC5R	1/53
84134140	1/2	84140000	1/9	GA86D05R	1/11	ODC5A	1/41	SMOACU	1/55
84134141	1/2	84140010	1/9	HS2	1/30	ODC5F	1/41	SMOACUA	1/55
84134180	1/2	84140100	1/9	HS3	1/31	ODC5MA	1/41	SMOACUAH	1/55
84134181	1/2	84140110	1/9	HS5	1/32	ODC5MC	1/41	SMODC24	1/53
84134200	1/2	84140200	1/9	HS6	1/32	ODC5ML	1/41	SMODC5	1/53
84134210	1/2	84140210	1/9	HS7	1/33	ODC5Q	1/49	SMODC5A	1/53
84134220	1/2	84140300	1/9	HS8	1/34	ODC5Q.11	1/49	SMODC5F	1/53
84134230	1/2	84140310	1/9	HS9	1/34	ORR24	1/57	SMODC5MA	1/53
84134240	1/2	84145001	1/19	HS10	1/35	ORR5	1/57	SMODC5MC	1/53
84134280	1/2	84145004	1/19	HS12	1/35	ORR5Q	1/57	SMODC5ML	1/53
84134300	1/2	84145005	1/19	HS13	1/31	PB16	1/74	SMORR24	1/57
84134310	1/2	84145010	1/19	HSP1	1/29	PB16C	1/74	SMORR5	1/57
84134320	1/2	84145011	1/19	HSP3	1/29	PB16C4	1/98		
84134330	1/2	84145015	1/19	IAC24	1/39	PB16C4T	1/99		

Products and specifications subject to change without notice.

Order/Technical Support – Tel: (800) 677-5311 / FAX: (800) 677-3865 / www.crouzet-usa.com



Products and specifications subject to change without notice.

Order/Technical Support – Tel: (800) 677-5311 / FAX: (800) 677-3865 / www.crouzet-usa.com

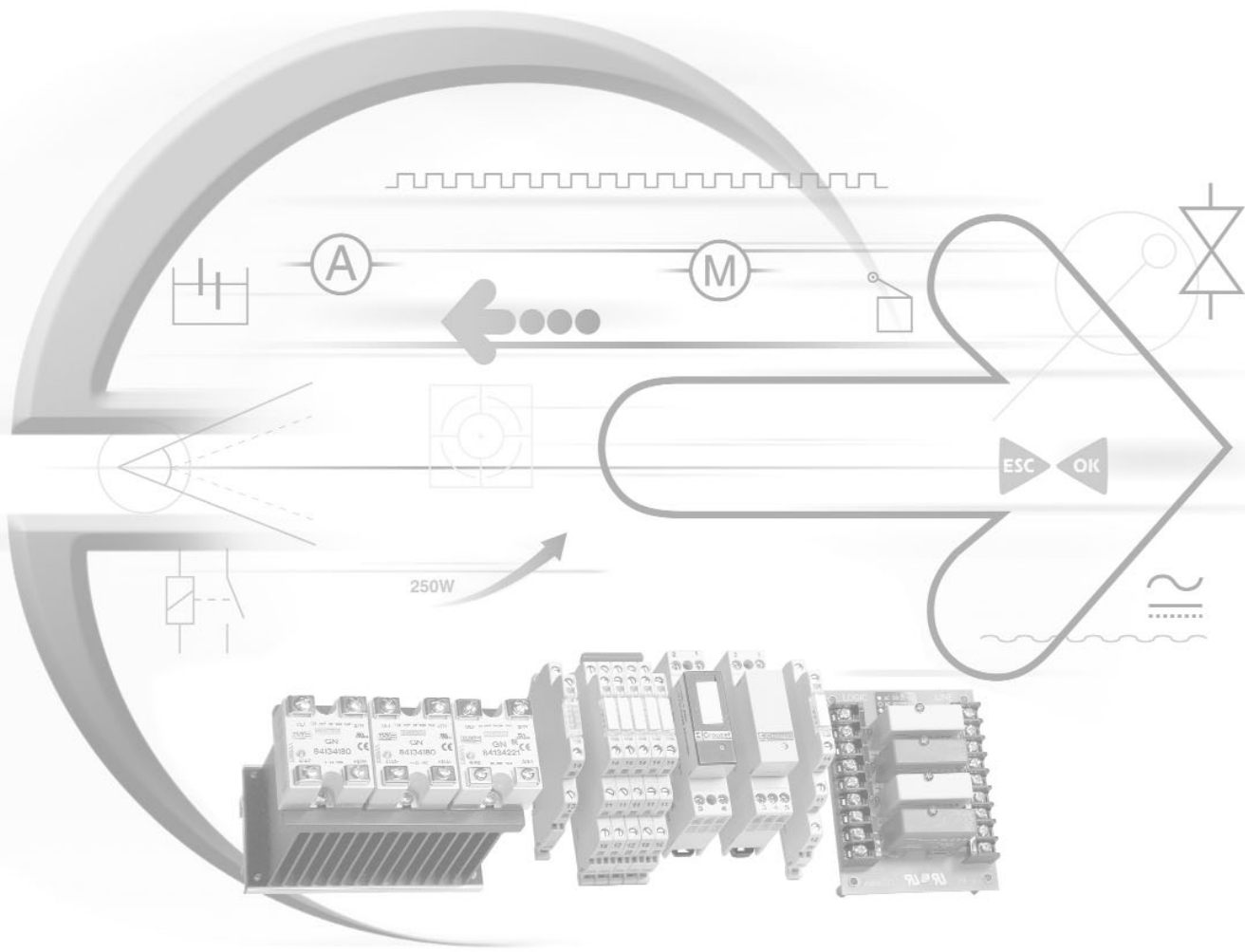

Solid State Relays



Products and specifications subject to change without notice.

Order/Technical Support – Tel: (800) 677-5311 / FAX: (800) 677-3865 / www.crouzet-usa.com

GN Series Solid State Relays

- ▶ Current ratings from 10 to 125 amps
- ▶ Output voltage from 24 to 660 Vac
- ▶ Back to back SCR's for severe inductive loads
- ▶ Direct bond copper substrate
- ▶ Improved power lead frame design
- ▶ LED input status indicator
- ▶ Transient protection built in
- ▶ 4000 Vac optical isolation
- ▶ Available with IP20 "touch-safe" cover
- ▶ UL E79183, CSA LR 38595, TUV Approved, CE Compliant

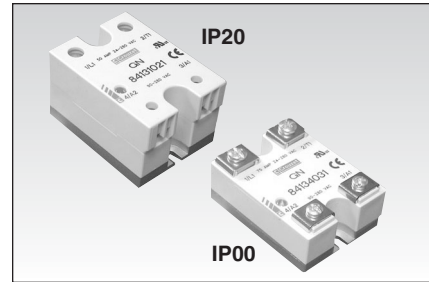

Output Specifications

Voltage range (Vrms)	24 - 280Vac	48 - 660Vac
Peak Voltage (Vpk, t = 1 min.)	600	1200
Off-state leakage (@ max. line voltage & Ta = 25°C)	0.1mArms	0.25mArms

Output Current (Mounted on proper heat sink, see deratings)	10	25	50	75	100	125
Minimum Current (mArms)	50	50	100	100	100	100
Max. 1 cycle surge current (Apk, Ta = 25°C)	150	300	750	1000	1200	1700
Max. 1 second surge current (Apk, Ta = 25°C)	30	75	150	225	300	375
Forward voltage drop (Vpk @ I _{max} , Ta = 25°C)	1.35	1.35	1.35	1.3	1.3	1.3
I ² T (60Hz, 1/2 cycle)	416	937	2458	5000	6000	12.041
R _{jb} (thermal res. Junction to baseplate, °C/W)	0.5	0.4	0.25	0.16	0.155	0.15
Static off-state dv/dt (V _{μs} , Ta = 25°C)	500	500	500	500	500	500
Minimum heat sink @ ambient (for max current = °C/W & Ta)	3.0@ 70°C	1.5@ 50°C	1.0@ 40°C	0.7@ 40°C	0.6@ 40°C	0.4@ 40°C

Input Specifications

Input voltage*	3-32Vdc	90-280Vac***
Drop out voltage	1Vdc	10Vrms
Max. input current	14mA	10mArms
Min. input current (for on-state)	7mA	5mArms
Input Resistance	Current Regulated	
Turn-on time**	8.33ms	20ms
Turn-off time	8.33ms	30ms

*4-32Vdc for 48-660Vac models

**Random SSR's turn on in less than 100μs

General Characteristics

Operating Temperature (°C)	-20 to +80
Storage Temperature (°C)	-40 to +100
Input to output isolation	4000Vrms
Input/output to ground isolation	2500Vrms
Input to output capacitance	8pF (typical)
Operating Frequency	47 to 63 Hz
Housing Material	UL 94V0 (self extinguishing)

Safety and Noise Immunity Compliance

CE Compliant with the LVD 73/23/EEC

UL / cUL Recognized per UL 508 and CSA C22.2 no. 14-M91

TUV EN60950

IEC 1000-4-2: Electrostatic Discharge – Level 3

IEC 1000-4-3: Radiated Electromagnetic Noise – Level 3

IEC 1000-4-4: Electrically Fast Transients – Level 3

IEC 1000-4-5: Electrical Surges – Level 3

IEC 1000-4-6: Conducted Electromagnetic Noise – Level 3

CISPR 11 – Class A: Allowable Levels of Conducted and Radiated Noise for Industrial Environments

*** For ambient temperatures above 40°C the maximum control voltage must not exceed 250Vac.

Part Numbers

(Zero Crossing)

Rating	Output	Input	IP00	IP20
10 Amp	24-280Vac	90-280Vac	84 134 001	84 137 001
		3-32Vdc	84 134 000	84 137 000
	48-660Vac	90-280Vac	84 134 101	84 137 101
25 Amp	24-280Vac	90-280Vac	84 134 011	84 137 011
		3-32Vdc	84 134 010	84 137 010
	48-660Vac	90-280Vac	84 134 111	84 137 111
50 Amp	24-280Vac	90-280Vac	84 134 021	84 137 021
		3-32Vdc	84 134 020	84 137 020
	48-660Vac	90-280Vac	84 134 121	84 137 121
75 Amp	24-280Vac	90-280Vac	84 134 031	84 137 031
		3-32Vdc	84 134 030	84 137 030
	48-660Vac	90-280Vac	84 134 131	84 137 131
100 Amp	24-280Vac	90-280Vac	84 134 041	84 137 041
		3-32Vdc	84 134 040	84 137 040
	48-660	90-260Vac	84 134 141	84 137 141
125 Amp	24-280Vac	90-280Vac	84 134 081	84 137 081
		3-32Vdc	84 134 080	84 137 080
	48-660Vac	90-280Vac	84 134 181	84 137 181
		3-32Vdc	84 134 180	84 137 180

Random SSR's

Rating	Output	Input	IP00	IP20
10 Amp	24-280Vac	3-32Vdc	84 134 200	84 137 200
	48-660Vac	3-32Vdc	84 134 300	84 137 300
25 Amp	24-280Vac	3-32Vdc	84 134 210	84 137 210
	48-660Vac	3-32Vdc	84 134 310	84 137 310
50 Amp	24-280Vac	3-32Vdc	84 134 220	84 137 220
	48-660Vac	3-32Vdc	84 134 320	84 137 320
75 Amp	24-280Vac	3-32Vdc	84 134 230	84 137 230
	48-660Vac	3-32Vdc	84 134 330	84 137 330
100 Amp	24-280Vac	3-32Vdc	84 134 240	84 137 240
	48-660Vac	3-32Vdc	84 134 340	84 137 340
125 Amp	24-280Vac	3-32Vdc	84 134 280	84 137 280
	48-660Vac	3-32Vdc	84 134 380	84 137 380

Dimensions – see page 1-4

Products and specifications subject to change without notice.

Order/Technical Support – Tel: (800) 677-5311 / FAX: (800) 677-3865 / www.crouzet-usa.com

GNA5 Series Solid State Relays

- ▶ Current ratings 10 and 25 amps
- ▶ Output voltage 24 to 280 Vac
- ▶ Triac output
- ▶ Regulated AC and DC inputs
- ▶ 4000 Vac optical isolation
- ▶ UL E79183, CSA LR 38595, TUV Approved, CE Compliant

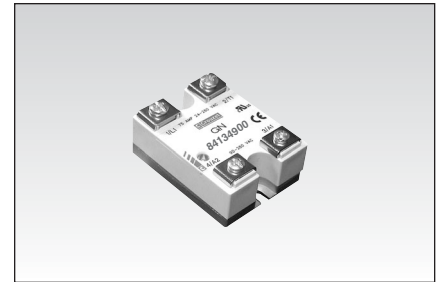

Output Specifications

Voltage range (Vrms)	24 - 280Vac	
Peak Voltage (Vpk, t = 1 min.)	600	
Off-state leakage (@ max. line voltage & Ta = 25°C)	0.10mArms	

Output Current (Mounted on proper heat sink, see deratings)	10	25
Minimum Current (mArms)	100	100
Max. 1 cycle surge current (Apk, Ta = 25°C)	100	250
Max. 1 second surge current (Apk, Ta = 25°C)	30	75
Forward voltage drop (Vpk @ Imax, Ta = 25°C)	1.5	1.3
IFT (60Hz, 1/2 cycle)	41	240
Rjb (thermal res. Junction to baseplate, °C/W)	2.2	1.7
Static off-state dv/dt (Vμs, Ta = 25°C)	500	500
Minimum heat sink @ ambient (for max current = °C/W & Ta)	3.0@ 40°C	1.0@ 40°C

Input Specifications

Input voltage*	3-32Vdc	90-280Vac**
Drop out voltage	1Vdc	10Vrms
Max. input current	14mA	8.5mArms
Min. input current (for on-state)	9.5mA	5mArms
Input Resistance	Current Regulated	
Turn-on time	8.33ms	20ms
Turn-off time	8.33ms	30ms

** For ambient temperatures above 40°C the maximum control voltage must not exceed 250Vac.

General Characteristics

Operating Temperature (°C)	-20 to +80
Storage Temperature (°C)	-40 to +100
Input to output isolation	4000Vrms
Input/output to ground isolation	2500Vrms
Input to output capacitance	8pF (typical)
Operating Frequency	47 to 63 Hz
Housing Material	UL 94V0 (self extinguishing)

Safety and Noise Immunity Compliance

CE Compliant with the LVD 73/23/EEC
UL / cUL Recognized per UL 508 and CSA C22.2 no. 14-M91 E46203
TUV EN60950
IEC 61000-4-2: Electrostatic Discharge – Level 3
IEC 61000-4-3: Radiated Electromagnetic Noise – Level 3
IEC 61000-4-4: Electrically Fast Transients – Level 3
IEC 61000-4-5: Electrical Surges – Level 3
IEC 61000-4-6: Conducted Electromagnetic Noise – Level 3
IEC 61000-4-11
CISPR 11 – Class A: Allowable Levels of Conducted and Radiated Noise for Industrial Environments

Part Numbers

Rating	Output	Input	IP00
10 Amp	24-280Vac	90-280Vac	84 134 901
		3-32Vdc	84 134 900
25 Amp	24-280Vac	90-280Vac	84 134 911
		3-32Vdc	84 134 910

Quick connect terminals: 3/16" input and 1/4" output

Rating	Output	Input	IP00
10 Amp	24-280Vac	90-280Vac	84 134 905
		3-32Vdc	84 134 904
25 Amp	24-280Vac	90-280Vac	84 134 915
		3-32Vdc	84 134 914

Quick connect terminals: 1/4" input and 1/4" output

Rating	Output	Input	IP00
10 Amp	24-280Vac	90-280Vac	84 134 909
		3-32Vdc	84 134 907
25 Amp	24-280Vac	90-280Vac	84 134 919
		3-32Vdc	84 134 917

DIMENSIONS IN INCHES

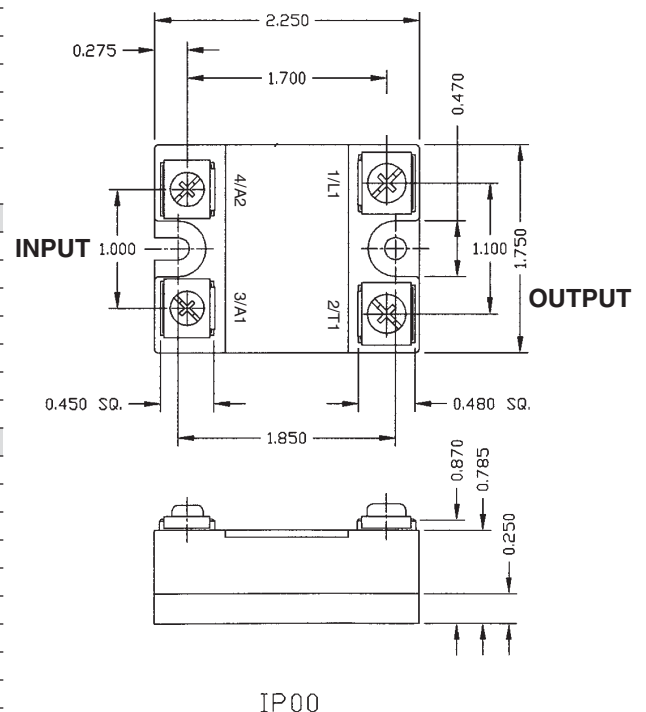

Products and specifications subject to change without notice.

Order/Technical Support – Tel: (800) 677-5311 / FAX: (800) 677-3865 / www.crouzet-usa.com

DIMENSIONS IN INCHES

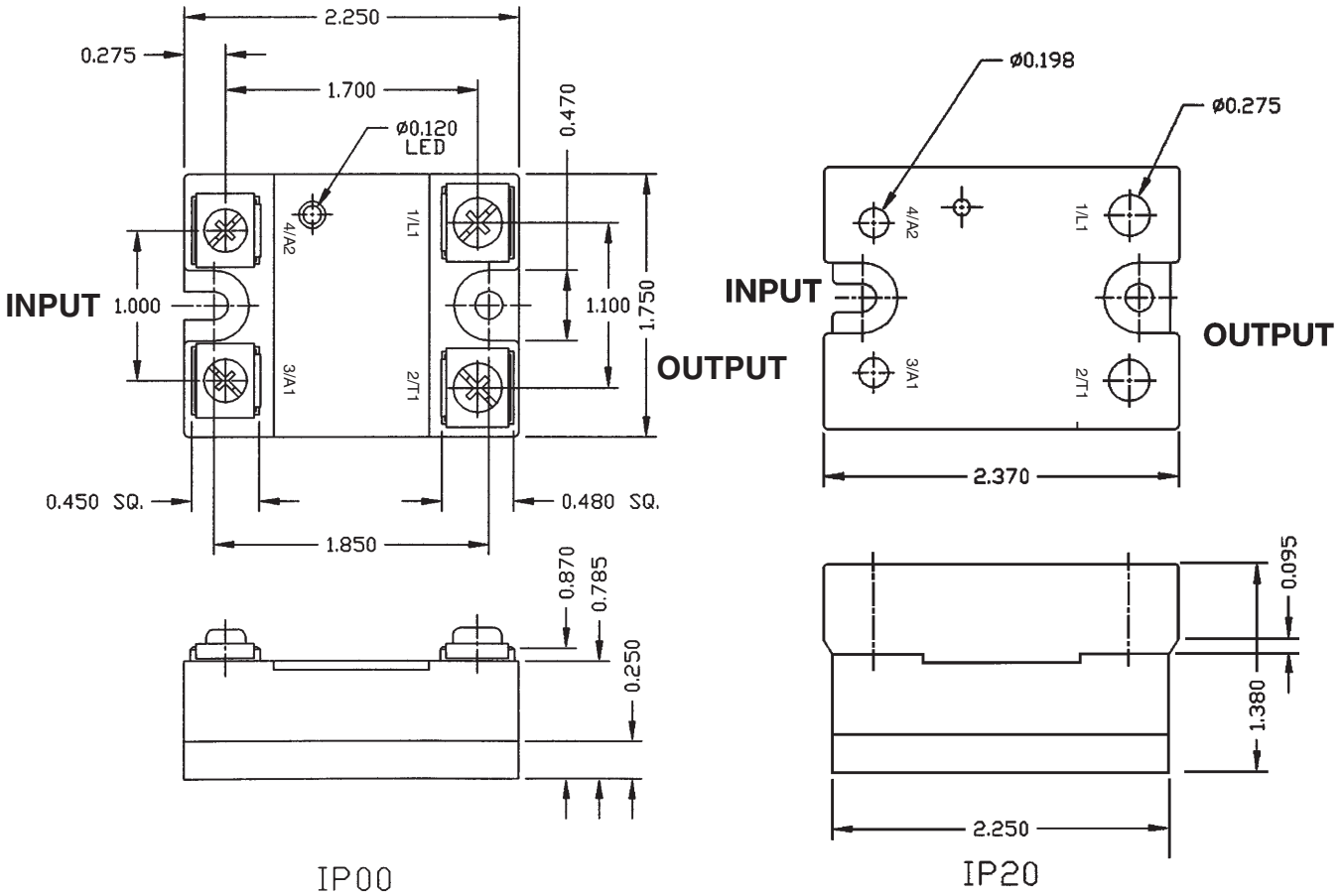

DERATING CURVES

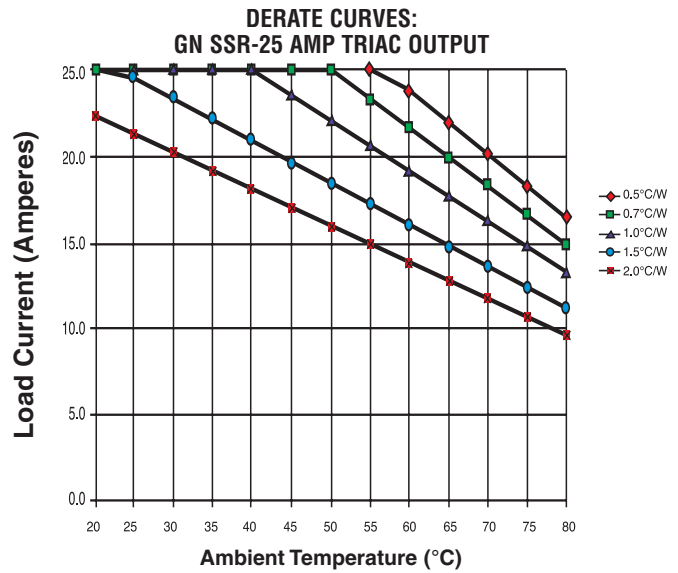
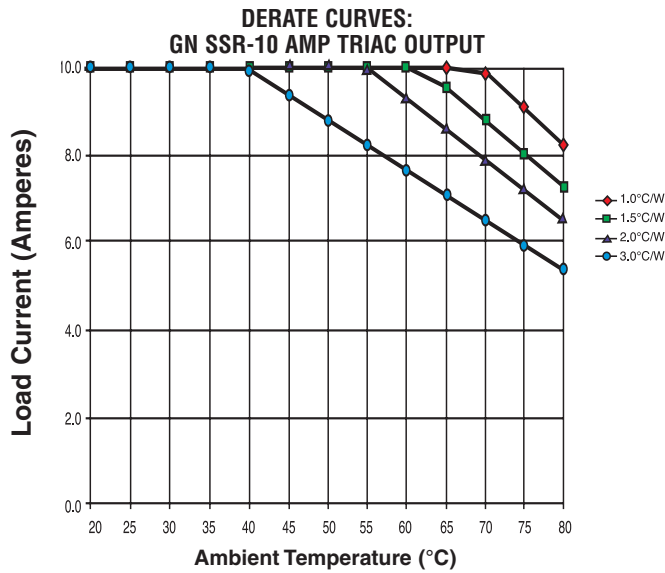

Products and specifications subject to change without notice.

Order/Technical Support – Tel: (800) 677-5311 / FAX: (800) 677-3865 / www.crouzet-usa.com

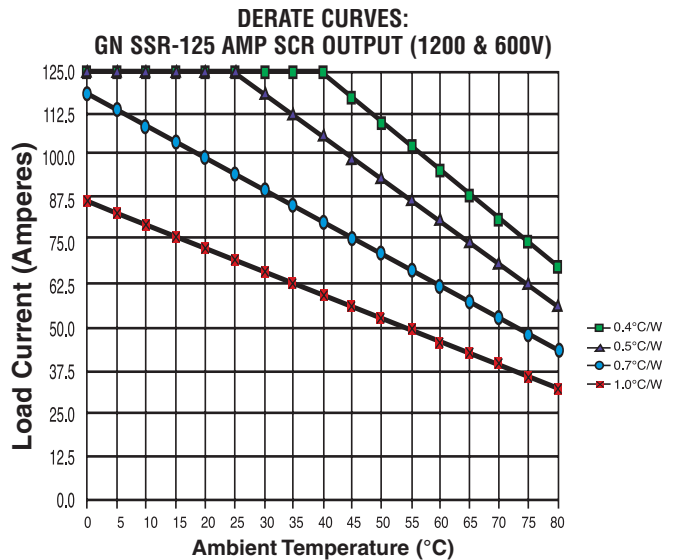
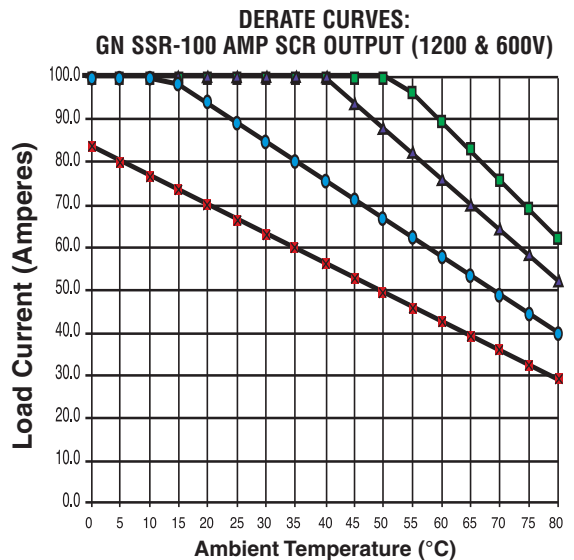
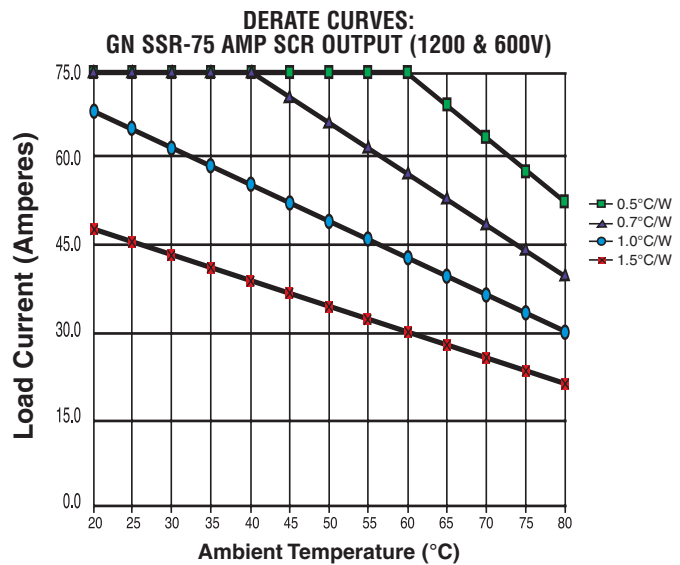
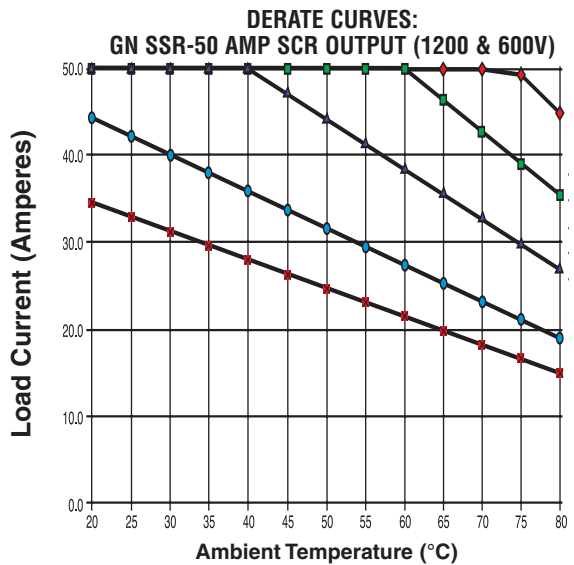
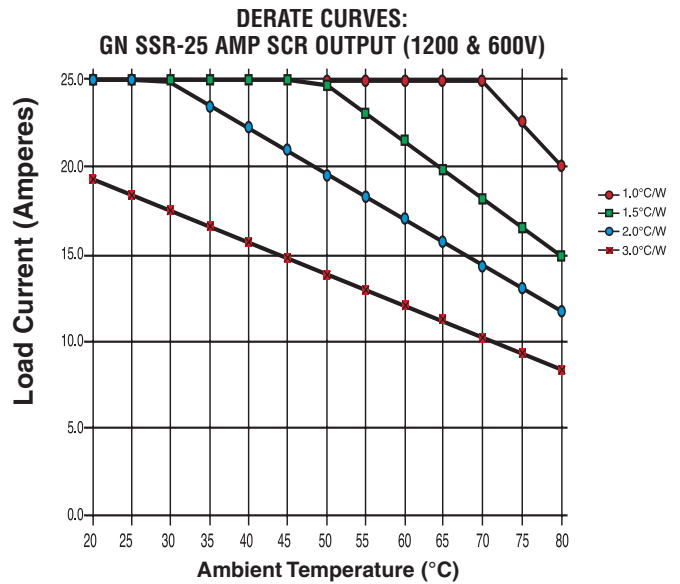
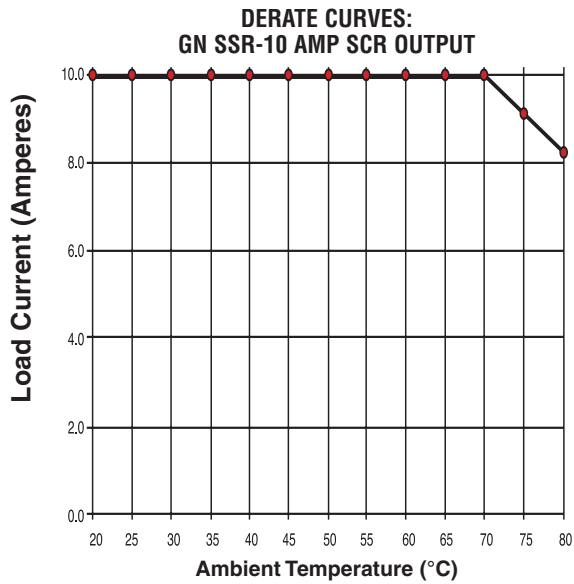

Products and specifications subject to change without notice.

Order/Technical Support – Tel: (800) 677-5311 / FAX: (800) 677-3865 / www.crouzet-usa.com

SOLID STATE RELAYS

“SMART MODULE”

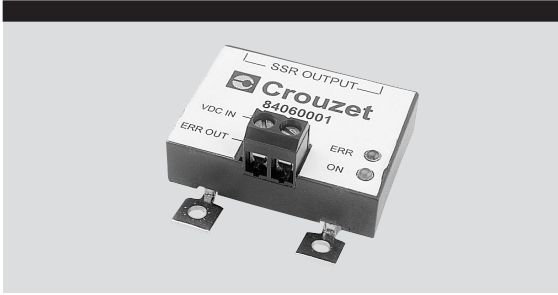

FEATURES:

- Supplies Electrical And Visual Feedback If An Error Occurs In The Circuit Or With The Host SSR
- 4 to 32 VDC Push-Pull Transistor Alarm Output
- 4000 VAC Optical Isolation
- 1200 VAC Peak Off-State Blocking Voltage Allows For Use With Any DC Input G & GA5 Series SSR
- UL/cUL Recognition Evaluation Pending
- Mounts On Any Standard Puck Style SSR

ELECTRICAL SPECIFICATIONS: (1)

INPUT:

Nominal Voltage	5-24 VDC
Maximum Voltage	32 VDC
Minimum Voltage	3 VDC
Off-State Voltage (2)	1 VDC

DC SUPPLY/ERROR SIGNAL:

Supply Voltage (3)	4-32 VDC
Supply Current (4)	15-30 mA
Error Output Voltage (5)	4-32 VDC
Error Output Current	30 mA

LINE VOLTAGE:

Line Voltage	24-660 Vrms
Off-State Blocking Voltage (6)	1200 Vpk
Off-State Leakage Current (7)	8 mArms

GENERAL SPECIFICATIONS:

Operating Temperature	-20° to +80°C
Storage Temperature	-40° to +100°C
Input To Output Isolation (8)	4000 Vrms
Turn-On Time	8.3 mSec
Turn-Off Time	8.3 mSec

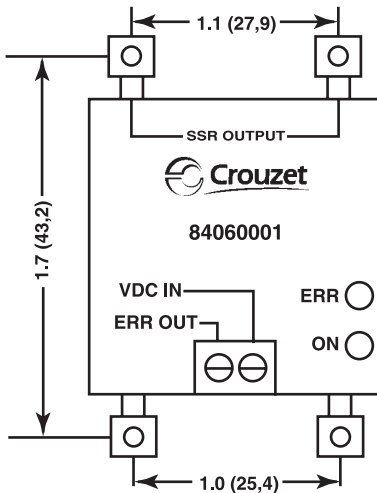

FUNCTION: (SMART MODULE ENERGIZED)

INDICATOR	STATUS		
	OFF	ON	BLINKING
ON (GREEN LED)	NO INPUT TO SSR	INPUT POWER TO SSR	N/A
ERROR (RED LED)	NORMAL OPERATION	INTERNAL SHORT	EXTERNAL SHORT OR OPEN CIRCUIT
ERROR OUTPUT SIGNAL	4-32VDC (DC SUPPLY)	0VDC (GROUND)	0VDC (GROUND)

Notes:

- (1) Specifications apply to an ambient of -20° to + 80°C unless otherwise specified
- (2) Defined as the maximum allowable voltage on the input terminals of the SSR for the module to “sense” an off-state condition
- (3) Referenced to pin #4 (common) of the SSR
- (4) 30 mA max @ 32 VDC supply voltage; current regulated
- (5) During normal operation of the SSR; Error output = DC supply voltage
- (6) Maximum 1 minute duration
- (7) At maximum line voltage
- (8) At 25°C for 1 second

Ordering Information
Part Number: **84060001**

Products and specifications subject to change without notice.

Order/Technical Support – Tel: (800) 677-5311 / FAX: (800) 677-3865 / www.crouzet-usa.com

SOLID STATE RELAYS

WIRING DIAGRAM:

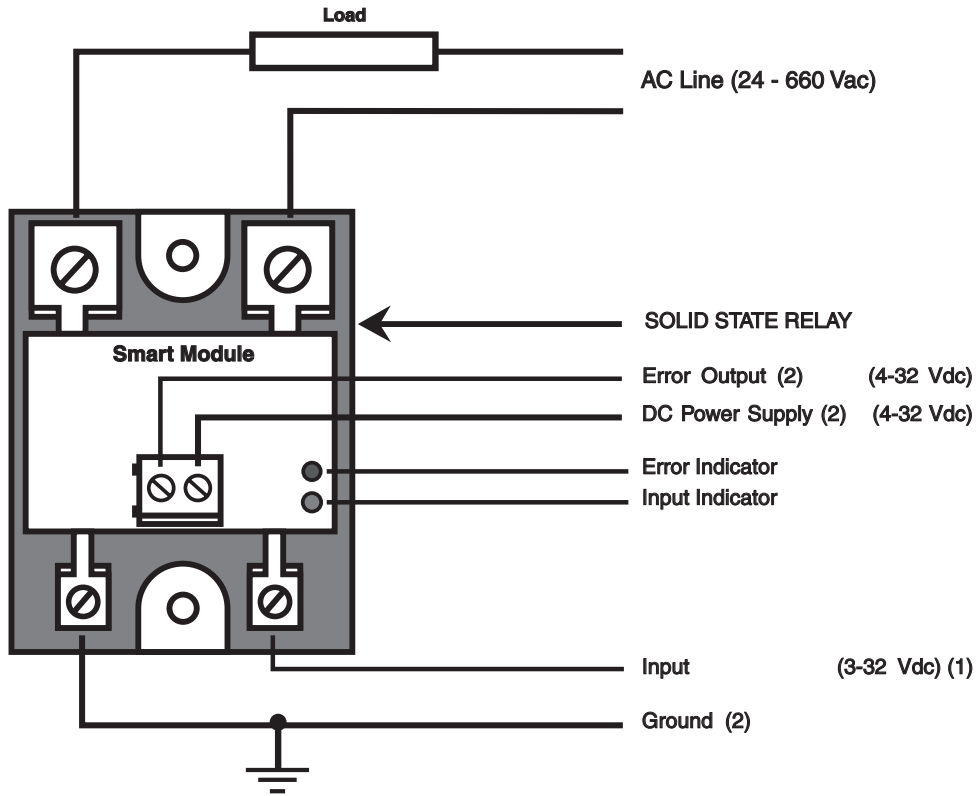

Note:

1. HV GN Series DC Input Range is 4-32 Vdc
2. Input, Outputs and DC Power Supply voltages are referred to the same common Ground

DC Solid State Relays

GF Series; FET output - 10A, 15 A, 30A

- ▶ Very low leakage current (< 10uA)
- ▶ Milliohm On-Resistance Minimizes voltage drop, heat dissipation
- ▶ 1500 VAC Optical Isolation
- ▶ UL/cUL recognized, Tuv approved, CE compliant

GT Series; transistor output 10A

- ▶ Long Life Switching of DC loads
- ▶ 4 kV Optical Isolation
- ▶ UL E46203
- ▶ Available with IP20 “touch-safe” cover

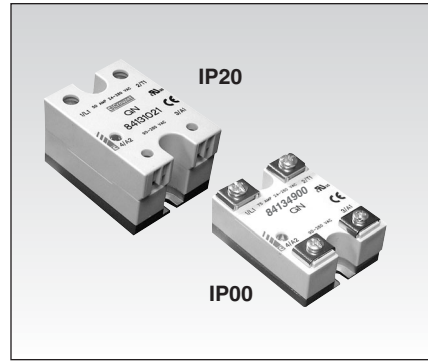

Output Specifications

Output	FET	FET	FET	TRAN
Voltage range VDC	1-200	1-100	1-50	3-60
Off-state leakage mA	0.01	0.01	0.01	1.0
Output Current (Mounted on proper heat sink, see deratings)	10	15	30	10
Minimum Current	0.1	0.1	0.1	10
Max. 1 second surge current	60	120	160	90
Max On-State Voltage Drop or On-State Resistance m Ohms	n/a	n/a	n/a	n/a
Rj/b (thermal res. Junction to baseplate, °C/W)	4.4	4.6	2.3	4.3
Minimum heat sink @ ambient (for max current = °C/W & Ta)	3.0 @ 25°C	3.0 @ 25°C	1.0 @ 25°C	1.0 @ 65°C

Input Specifications

Input voltage*	3-32Vdc			
Drop out voltage	1Vdc			
Max. input current (mA)	20	20	20	14.5
Min. input current (for on-state) m	12	12	12	9
Input Resistance	Current Regulated			
Max. Turn-on time (mS)	2	2	2	.1
Max. Turn-off time (uS)	50	50	50	200

General Characteristics

Operating Temperature (°C)	-20 to +80
Storage Temperature (°C)	-40 to +100
Input to output isolation	4000Vrms
Input/output to ground isolation	2500Vrms
Input to output capacitance	8pF (typical)
Housing Material	UL 94V0 (self extinguishing)

Safety and Noise Immunity Compliance

CE Compliant with the LVD 73/23/EEC

TUV EN60950

Part Numbers

FET Output

Rating	Output	Input	IP00	IP20
10 Amp	1-200Vdc	3-32Vdc	84 134 850	84 137 850
15 Amp	1-100Vdc	3-32Vdc	84 134 860	84 137 860
30 Amp	1-50Vdc	3-32Vdc	84 134 870	84 137 870

Transistor Output

10 Amp	3-60Vdc	3-32Vdc	84 134 750	84 137 750
--------	---------	---------	------------	------------

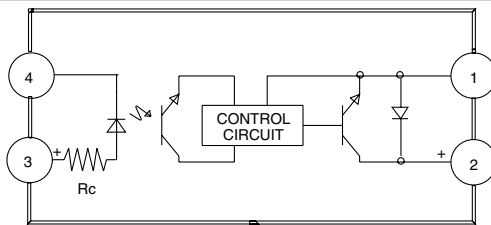
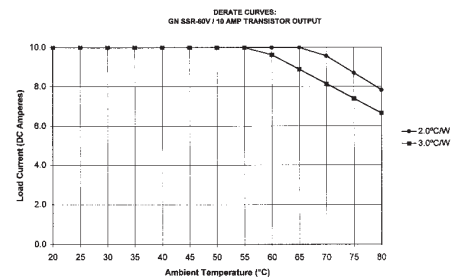
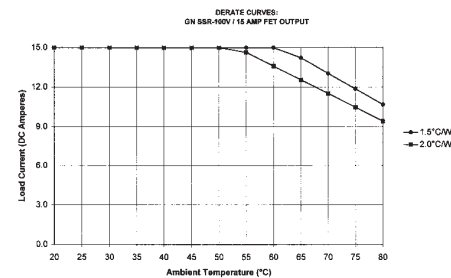
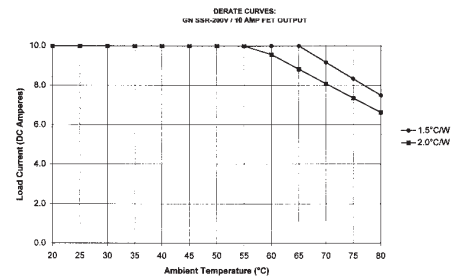
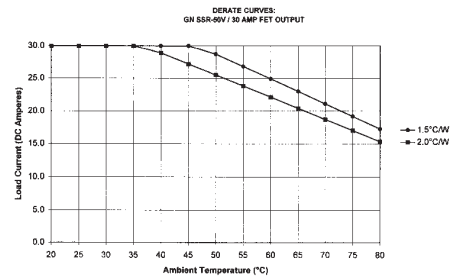

GT SERIES EQUIVALENT CIRCUIT

DC inductive loads must be diode suppressed to prevent damage to SSR

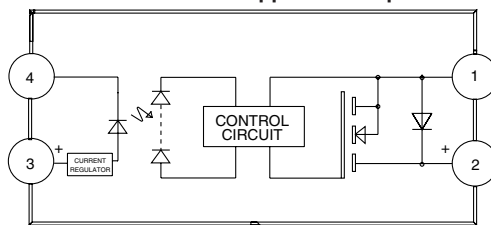

GF SERIES EQUIVALENT CIRCUIT

Products and specifications subject to change without notice.

Order/Technical Support – Tel: (800) 677-5311 / FAX: (800) 677-3865 / www.crouzet-usa.com

Dual Solid State Relays

- ▶ 40 amp dual AC output relays
- ▶ Output voltage from 24 to 280 Vac
- ▶ Direct bond copper substrate
- ▶ Back to back dual SCR output
- ▶ 4000 Vac optical isolation
- ▶ Zero crossing or random turn on
- ▶ UL/cUL E79183, CE Compliant

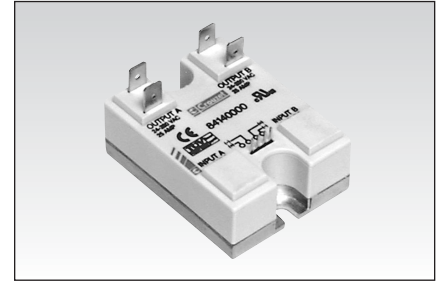

Output Specifications

	24 - 280Vac	24 - 280Vac
Voltage range (Vrms)	24 - 280Vac	24 - 280Vac
Peak Voltage (Vpk, t = 1 min.)	550	550
Off-state leakage mArms (@ max. line voltage & Ta = 25°C)	0.1	0.1
Output Current (Mounted on proper heat sink, see deratings)	25	40
Minimum Current (mArms)	100	100
Max. 1 cycle surge current (Apk, Ta = 25°C)	500	780
Max. 1 second surge current (Apk, Ta = 25°C)	150	234
Forward voltage drop (Vpk @ Imax, Ta = 25°C)	1.4	1.3
I ² T (60Hz, 1/2 cycle)	1041	2435
R _{jb} (thermal res. Junction to baseplate, °C/W)	0.6	0.4
Static off-state dv/dt (V μ s, Ta = 25°C)	500	500

Input Specifications

	4-15Vdc	17-32Vdc
Input voltage	4-15Vdc	17-32Vdc
Drop out voltage	1Vdc	1Vdc
Min. input current (for on-state)	7.5mA	13mA
Maximum input current	34mA	24mA
Input Resistance (Ohms)	500	1500
Turn-on time*	8.33msec	8.33msec
Turn-off time	8.33msec	8.33msec

*Random SSR's turn on in less than 100 μ s

General Characteristics

Operating Temperature (°C)	-40 to +80
Storage Temperature (°C)	-40 to +100
Input to output isolation	4000Vrms
Input/output to ground isolation	2500Vrms
Input to output capacitance	8pF (typical)
Operating Frequency	47 to 63 Hz
Housing Material	UL 94V0 (self extinguishing)

Standards of Compliance

CE Compliant with the LVD 73/23/EEC
UL / cUL Recognized per UL 508 and CSA C22.2 no. 14-M91

Part Numbers

Zero Crossing Output			
Rating	Output	Input	Part Number
25 Amp	24-280Vac	4-15Vdc	84 140 000
25 Amp	24-280Vac	17-32Vdc	84 140 010
40 Amp	24-280Vac	4-15Vdc	84 140 200
40 Amp	24-280Vac	17-32Vdc	84 140 210
Random Fire Output			
Rating	Output	Input	Part Number
25 Amp	24-280Vac	4-15Vdc	84 140 100
25 Amp	24-280Vac	17-32Vdc	84 140 110
40 Amp	24-280Vac	4-15Vdc	84 140 300
40 Amp	24-280Vac	17-32Vdc	84 140 310

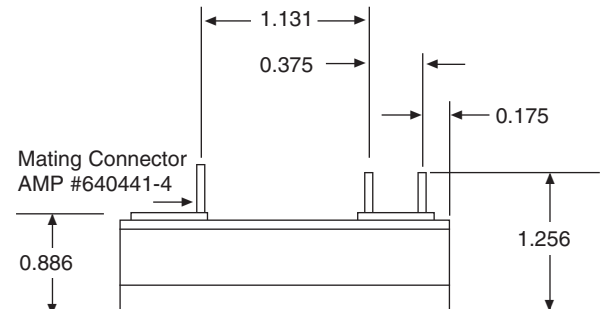
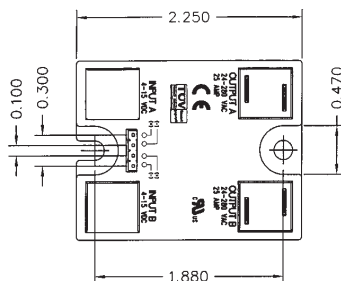
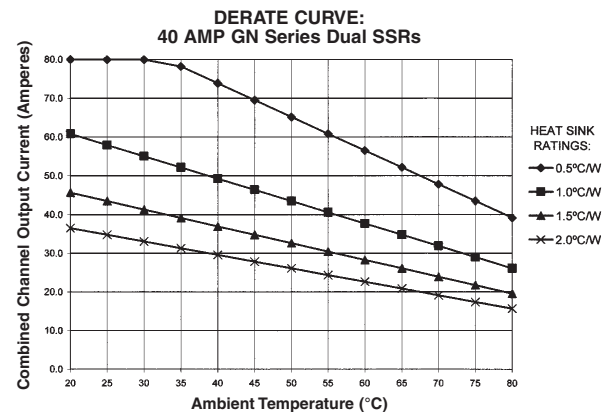
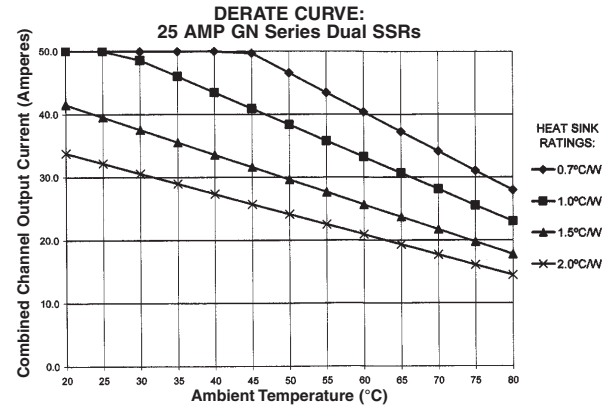

Products and specifications subject to change without notice.

Order/Technical Support – Tel: (800) 677-5311 / FAX: (800) 677-3865 / www.crouzet-usa.com

SOLID STATE RELAYS

GA1, GA8, SERIES

- High Current Thyristor for 100A Surge Capability
- UL Recognized/Horse Power Rated (GA8) (E46203)
- 4KV Optical Isolation
- Zero Voltage Turn-On
- Industry Standard Packaging, SIP or Flat Pack
- Form A Output
- CE Compliant



GA1

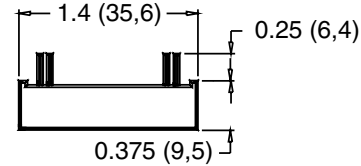
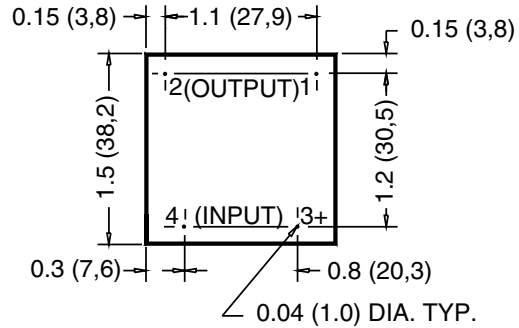

DIMENSIONS: inches (mm)
TOLERANCE: ±0.020 (±0,50)

GA8

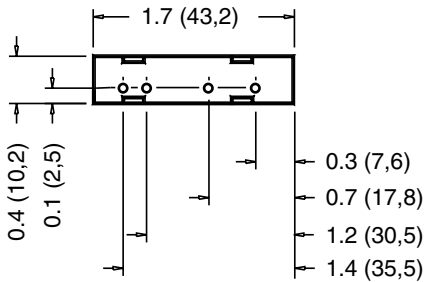
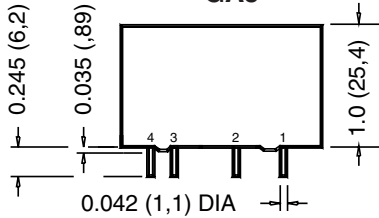

DIMENSIONS: inches (mm)
TOLERANCE: ±0.020 (±0,50)

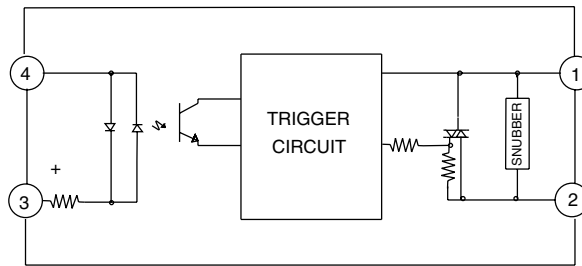

GA1 & GA8 SERIES DC INPUT
 EQUIVALENT CIRCUIT

SOLID STATE RELAYS

GA1, GA8, SERIES

INPUT SPECIFICATIONS: (1)

Parameter	GA16B02	GA86D05	Units
	GA86B02	GA86D05R	
Minimum Turn-On Voltage	3.0	3.0	VDC
Maximum Input Voltage	28	28	VDC
Drop Out Voltage	1.0	1.0	VDC
Maximum Input Current (2)	25	25	mADC
Nominal Input Resistance (3)	1K	1K	Ω

OUTPUT SPECIFICATIONS:

Model Number	GA16B02 (10)	GA86D05	Units
	GA86B02	GA86D05R	
Parameter			
Nominal Line Voltage	240	240	Vrms
Minimum Line Voltage	24	24	Vrms
Maximum Line Voltage	280	280	Vrms
Maximum Peak Off-State Voltage(4)	±600	±600	Vpeak
Static (Off-State) dv/dt	200	200	V/μS

Parameter	GA16B02	GA86D05	Units
	GA86B02	GA86D05R	
Maximum On-State Current (5)	4.0	5.0	Arms
Minimum On-State Current	.05	.05	Arms
Maximum 1-Cycle Surge (6)	100	100	Apeak
On-State Voltage Drop (7)	1.6	1.6	Vpeak
Maximum Off-State Leakage (8)			
240V Models	.1	.1	mArms
HP Rating (11)	1/4	1/4	H.P.

GENERAL SPECIFICATION: (1)

Parameter	All Devices	Units
Operating Temperature Range	-30 to +80	°C
Storage Temperature Range	-40 to +100	°C
Response Time (12)	.5	Cycle
Input to Output Isolation Voltage (9)	4000	Vrms
Capacitance Input to Output (Typ)	8	pF
Line Frequency Range	47 to 63	Hz

Note: GA1-2B and GA1-4B have been replaced by GA1-6B
GA8-2B and GA8-4B have been replaced by GA8-6B

Notes:

- (1) Specifications apply to Ta -30 TO +80 unless otherwise noted.
- (2) At maximum input voltage.
- (3) Does not include IRED impedance (drop).
- (4) One minute maximum duration when applied as a DC Voltage.
- (5) At Ta of 20°C, derate by 25 mA/°C to 40°C, 50 mA/°C from 40°C to 80°C. UL rating is 3.5 Arms, CSA rating is 3.0 Arms.
- (6) At Ta of 25°C, non-repetitive.
- (7) At Ta of 25°C and maximum on-state current.
- (8) At Ta of 25°C and maximum line voltage.
- (9) At Ta of 25°C, for one second.
- (10) Random turn-on versions available. Specify by adding suffix "R" to appropriate part number. Contact factory for additional details.
- (11) For GA8 only, 1/4 H.P. at 240 VAC, 1/8 HP at 120 VAC
- (12) AT 60 Hz 100 μS for Random Turn-on (suffix "R") models

5 AMP. GA8 DERATING CURVE

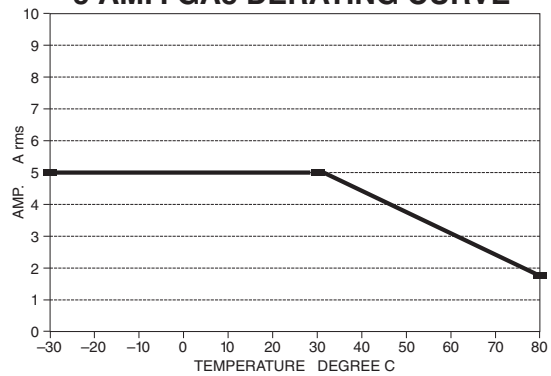

Products and specifications subject to change without notice.

Order/Technical Support – Tel: (800) 677-5311 / FAX: (800) 677-3865 / www.crouzet-usa.com

SOLID STATE RELAYS

THREE-PHASE SOLID STATE RELAYS

- 10, 25 and 45 Amps Output Per Channel Available
- 24 to 600 VAC Output Voltage Range Suitable for Many Applications
- 1200 Volts Peak Blocking Voltage Helps Protect Against Transients in Harsh Electrical Environments
- Internal RC Snubber Network
- 4000 VAC Optical Isolation
- 4 to 32 Control Voltage for a Wide Variety of Logic Circuit Applications
- Zero Voltage or Random Turn-on
- Industry Standard Package
- UL Recognized (E74183) 10 hp 480 VAC, CSA Certified (LR38545)
- CE Compliant

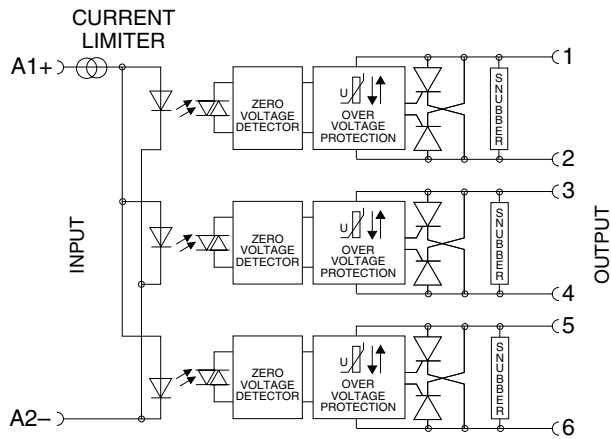

DIMENSIONS: INCHES (MILLIMETERS)
TOLERANCE: ±0.020 (±0.50)

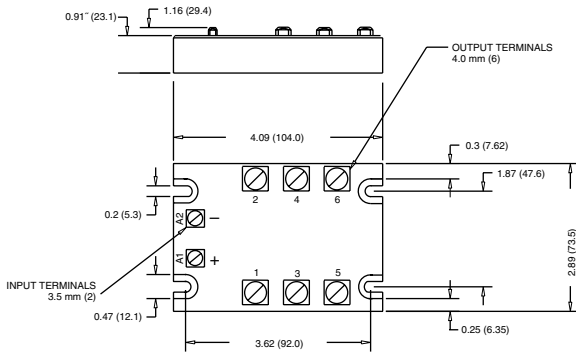

GA3 3 PHASE SSR DERATING CURVES:
45 AMP

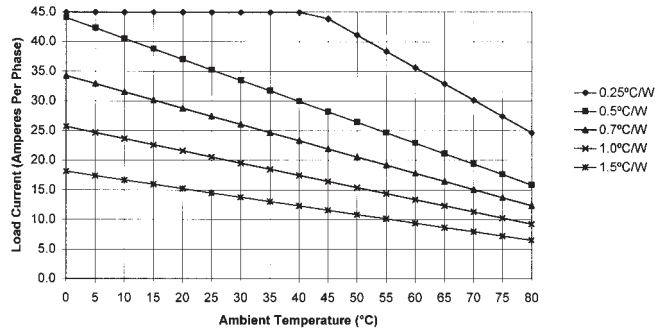

GA3 3 PHASE SSR DERATING CURVES:
10 AMP

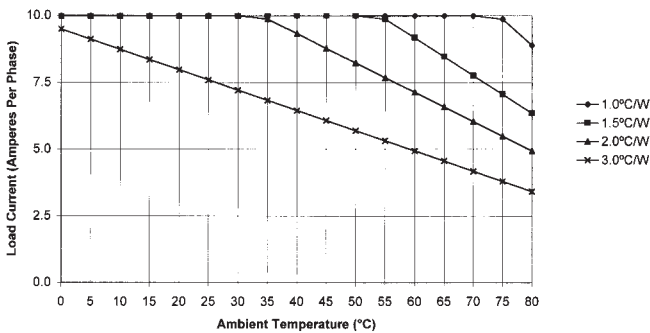

GA3 3 PHASE SSR DERATING CURVES:
25 AMP

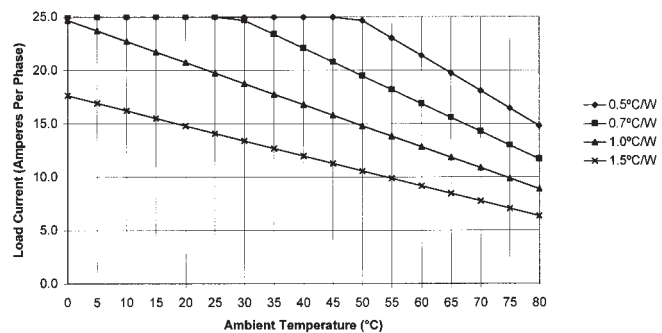

Products and specifications subject to change without notice.

Order/Technical Support – Tel: (800) 677-5311 / FAX: (800) 677-3865 / www.crouzet-usa.com

SOLID STATE RELAYS

THREE-PHASE SOLID STATE RELAYS

INPUT SPECIFICATIONS: (1)

Model Number	GA312D10R GA312D10Z GA312D25R	GA312D25Z GA312D45R GA312D45Z	GA312A25R GA312A25Z GA312A45R GA312A45Z
Parameter			
Voltage Range	4.0 to 32.0 VDC		90-280 VAC
Drop Out Voltage	1.0 VDC		10 VAC
Control Current (2)	20 mA		10 mA

OUTPUT SPECIFICATIONS: (1)

Model Number	GA312D10R GA312D10Z	GA312A25R GA312A25Z GA312D25R GA312D25Z	GA312A45R GA312A45Z GA312D45R GA312D45Z	Units
Parameter				
Line Voltage Range	24 to 660	24 to 660	24 to 660	VAC
SSR Maximum Peak Off-State Voltage (3)	1200	1200	1200	Vpeak
Rated Current (4)	10	25	45	Arms
Minimum Current	0.2	0.2	0.2	Arms
Maximum Off-State Leakage (5)	10.0	10.0	10.0	mArms
One Cycle Surge Current (6)	160	270	450	Apeak
I ² t Fusing Current	128	365	1000	A ² Seconds
Maximum On-State Voltage Drop (7)	1.6	1.6	1.6	Volts
Off-State dv/dt (8)	500	500	500	V/μSec

GENERAL SPECIFICATIONS: (1)

Parameter	GA312D10R GA312D25R GA312D45R	GA312D10Z GA312D25Z GA312D45Z	GA312A25R GA312A25Z GA312A45R GA312A45Z	UNITS
Operating Temperature Range	-30 to 80°C	-30 to 80°C	-30 to 80°C	°C
Storage Temperature Range	-40 to 100°C	-40 to 100°C	-40 to 100°C	°C
Maximum Turn-on Time (9)	.20	8.33	20	mSec
Maximum Turn-off Time (10)	8.33	8.33	30	mSec
Input/Output Isolation (11)	4000	4000	4000	VAC
Input/Output to Base Isolation (11)	4000	4000	4000	VAC
Input/Output Capacitance (typical)	8	8	8	pF
Line Frequency Range	47 to 63	47 to 63	47-63	Hz
Weight	450	450	450	g

GA3 SERIES 3 PHASE SOLID STATE RELAY PART NUMBER SELECTION GUIDE

OUTPUT RATING	10A	25A	45A
FUNCTION	GA312D10R	GA312A25R	GA312A45R
Random Turn-on		GA312D25R	GA312D45R
Zero Voltage Turn-on	GA312D10Z	GA312A25Z GA312D25Z	GA312A45Z GA312D45Z

Notes:

- (1) Specifications apply to each phase at an ambient temperature of -20 to 80°C unless otherwise noted.
- (2) Input is regulated and current limited.
- (3) 1000 V peak with Transorb® protection. Applying 1000V or greater will increase the off-state leakage and may result in relay failure if applied for longer than 1 second.
- (4) See thermal dissipation/derating chart for heat sinking requirements. Catalog number HS-7 heat sink available separately for mounting GA3 series SSR's.
- (5) At 480 VAC line voltage, 25°C.
- (6) One AC cycle maximum duration, non-repetitive, 25°C.
- (7) At rated output current, 25°C.
- (8) Minimum dv/dt per EIA/NARM RS443, method RS397, 25°C.
- (9) At minimum input voltage, maximum line voltage, rated output current, 25°C.
- (10) At maximum input voltage, maximum line voltage, rated output current, 25°C.
- (11) At 25°C for 1 second maximum duration.

Products and specifications subject to change without notice.

Order/Technical Support – Tel: (800) 677-5311 / FAX: (800) 677-3865 / www.crouzet-usa.com

SOLID STATE RELAYS

THREE-PHASE MOTOR REVERSING RELAYS

- Convenient Self-Contained Design Eases Installation and Wiring
- 24 to 600 VAC Output Voltage Range Suitable for Many Applications
- 1000 Volts Peak Blocking Voltage Helps Protect Against Transients in Harsh Electrical Environments
- 5000 VAC Isolation
- 3 to 32 Control Voltage for a Wide Variety of Logic Circuit Applications
- Compact Sealed Package with Screw Terminals
- Interlock Circuit Prevents Inadvertant Actuation of Both Directions
- UL and cUL Recognized E79183
- CE Compliant

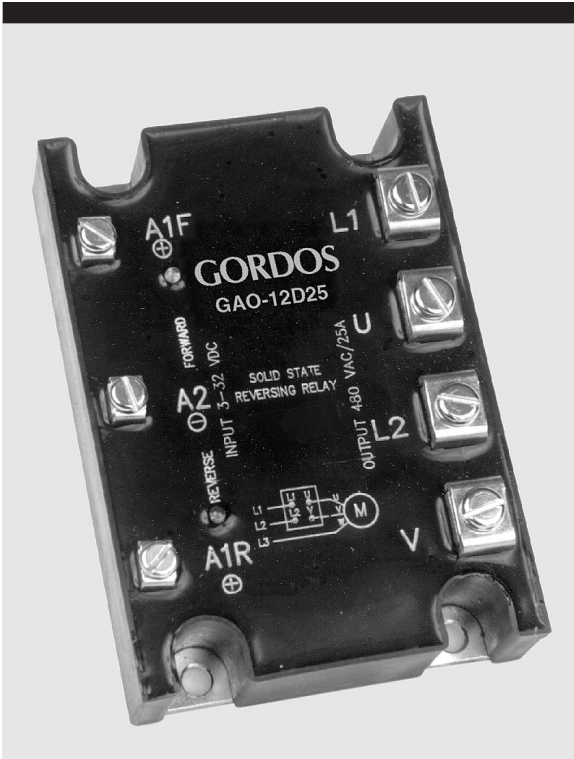

DIMENSIONS: INCHES (MILLIMETERS)
TOLERANCE: ±0.020 (±0.50)

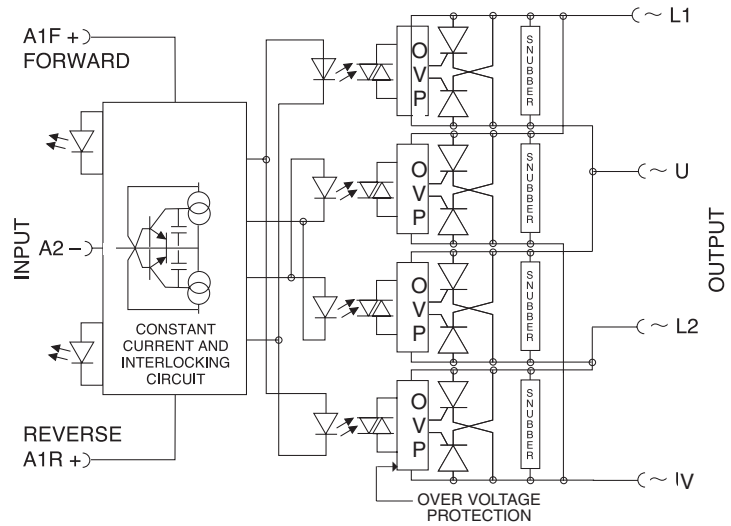
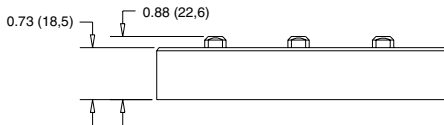

EQUIVALENT CIRCUIT

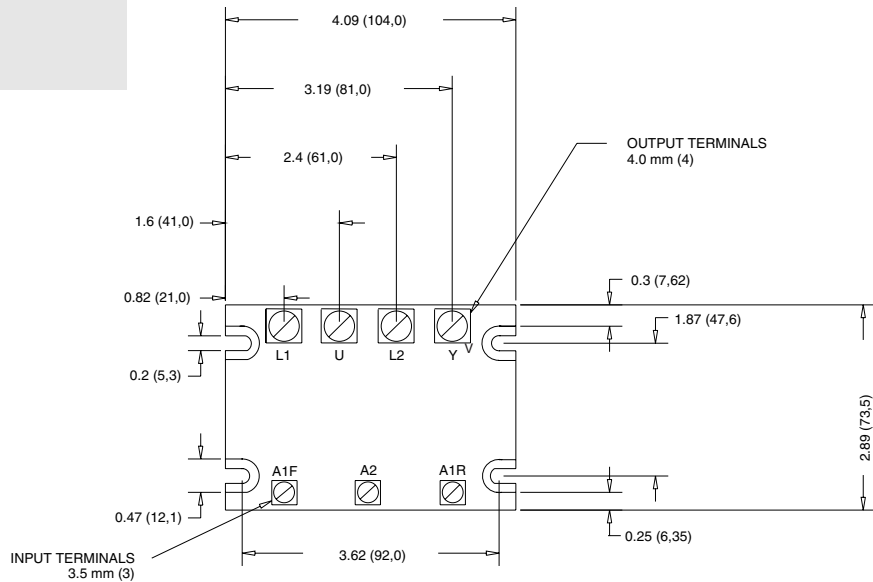

Products and specifications subject to change without notice.

Order/Technical Support – Tel: (800) 677-5311 / FAX: (800) 677-3865 / www.crouzet-usa.com

SOLID STATE RELAYS

THREE-PHASE MOTOR REVERSING RELAYS

INPUT SPECIFICATIONS: (1)

MODEL NUMBER	GA012D25	GA012D40	Units
Parameter			
Voltage Range	3.0 to 32		VDC
Drop Out Voltage	1.0		VDC
Control Current (2)	25		mA

OUTPUT SPECIFICATIONS: (1)

MODEL NUMBER	GA012D25	GA012D40	Units
Parameter			
Line Voltage Range	24 to 660	24 to 660	VAC
Maximum Peak Off-State Voltage (3)	1200	1200	Vpeak
Rated Current (4)	25	40	Arms
Minimum Current	0.2	0.2	Arms
Maximum Off-State Leakage (5)	.25	.25	mArms
One Cycle Surge Current (6)	270	450	Apeak
I ² t Fusing Current	365	1000	A Seconds
Maximum On-State Voltage Drop (7)	1.6	1.6	Volts peak
Off-State dv/dt (8)	500	500	V/μSec

GENERAL SPECIFICATIONS: (1)

Parameter	All Devices
Operating Temperature Range	-30 to 80°C
Storage Temperature Range	-40 to 100°C
Maximum Turn-on Time (9)	150 ms
Maximum Turn-off Time (10)	1/2 cycle
Input/Output Isolation (11)	4000 VAC
Input/Output to Base Isolation (11)	2500 VAC
Input/Output Capacitance (typical)	8 pF
Line Frequency Range	47 to 63 Hz
Weight	455 grams
Interlocking Time	100 mSec

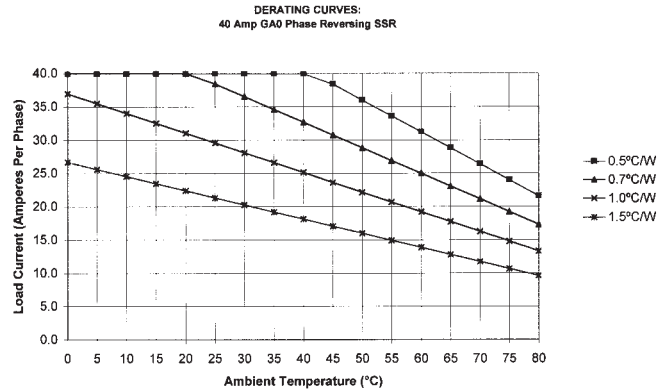

GAO THERMAL DISSIPATION CURVES

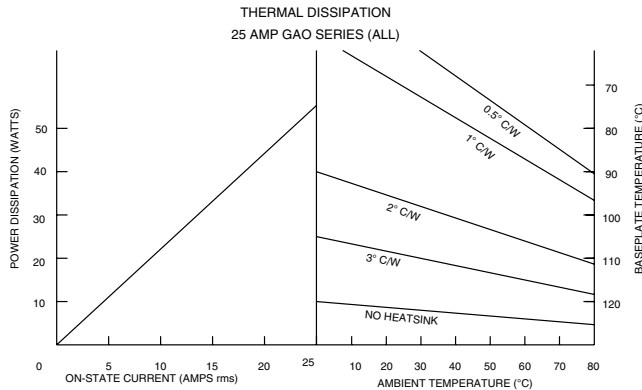

Notes:

- (1) Specifications apply to each phase at an ambient temperature of -20 to 80°C unless otherwise noted.
- (2) Input is regulated and current limited.
- (3) Semiconductors rated at 1200 V.
- (4) See thermal dissipation/derating chart for heat sinking requirements. Catalog number PR250/100SE2 heat sink available separately for mounting GAO series SSR's.
- (5) At maximum line voltage, 25°C.
- (6) One AC cycle maximum duration, non-repetitive, 25°C.
- (7) At rated output current, 25°C.
- (8) Minimum dv/dt per EIA/NARM RS443, method RS397, 25°C.
- (9) At minimum input voltage, maximum line voltage, rated output current, 25°C.
- (10) At maximum input voltage, maximum line voltage, rated output current, 25°C.
- (11) At 25°C for 1 second maximum duration.

Products and specifications subject to change without notice.

Order/Technical Support – Tel: (800) 677-5311 / FAX: (800) 677-3865 / www.crouzet-usa.com

SOLID STATE RELAYS

GZ SERIES SSR

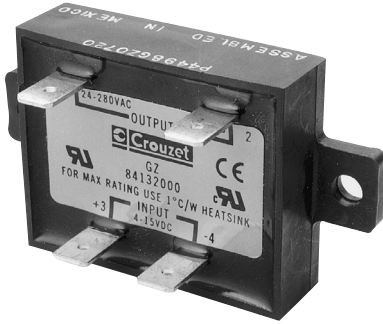

FEATURES:

- 12 & 20 Amp AC Output Relays
- Low Profile Package
- Economical Triac Output
- 4000 VAC Optical Isolation
- Zero Crossing or Random Turn-On
- UL/cUL Recognized E46203

DIMENSIONS:

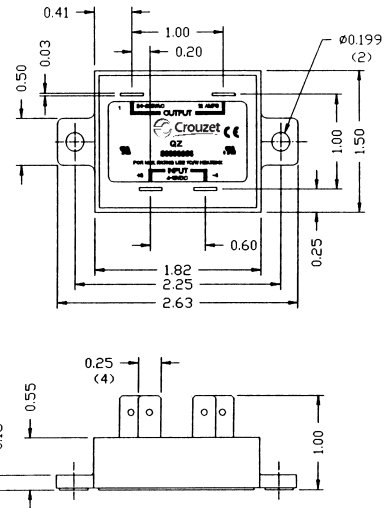

DERATE CURVES: LOW CURRENT STANDARD GZ SSRs

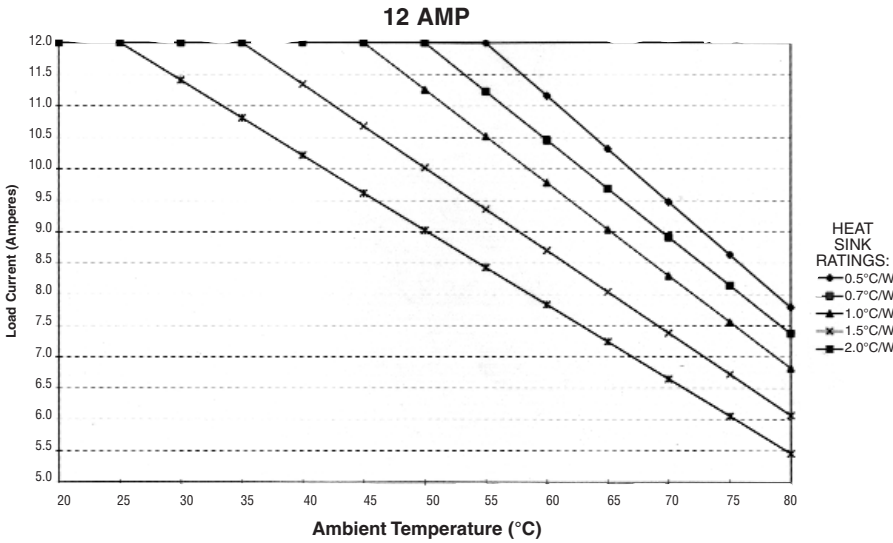

DERATE CURVES: HIGH CURRENT STANDARD GZ SSRs

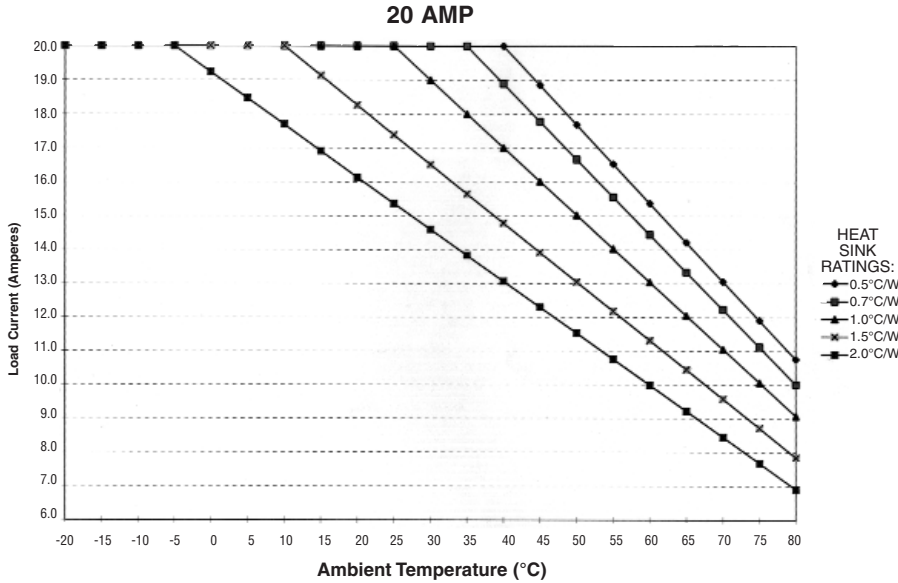

WIRING:

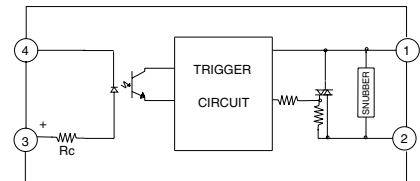

GZ SERIES DC INPUT EQUIVALENT CIRCUIT

Products and specifications subject to change without notice.

Order/Technical Support – Tel: (800) 677-5311 / FAX: (800) 677-3865 / www.crouzet-usa.com

SOLID STATE RELAYS

GZ SERIES SSR

INPUT SPECIFICATIONS:

Model Number Parameter	84132000	84132100	84132400	84132510	Units
	84132010	84132110	84132500	84132510	
Control Voltage	4-15	4-15	4-15	4-15	VDC
Drop Out Voltage	1.0	1.0	1.0	1.0	VDC
Maximum Input Current (1)	32	32	32	32	mA
Maximum Turn-On Time	8.33	0.1	0.1	0.1	ms
Maximum Turn-Off Time	8.33	8.33	8.33	8.33	ms
Type	Zero Crossing	Zero Crossing	Random Turn-On	Random Turn-On	

OUTPUT SPECIFICATIONS:

Model Number	84132000	84132010	84132400	84132410	Units
	84132100	84132110	84132500	84132510	
Line Voltage	24-280	24-280	36-530	36-530	Vrms
Peak Off-State Voltage (2)	600	600	800	800	Vpeak
Maximum Off-State Leakage (3)	0.1	0.1	0.1	0.1	mArms
Static Off-State dv/dt	250	250	250	250	V/μSec
Minimum On-State Current	0.1	0.1	0.1	0.1	Arms
Maximum On-State Current (4)	12	20	12	20	Arms
Maximum 1-Cycle Surge (5)	120	200	120	200	Apeak
Maximum 1-Second Surge (6)	36	60	36	60	Apeak
Peak On-State Voltage Drop (7)	1.65	1.55	1.65	1.55	Vpeak
I ² t (60 Hz, Half-Cycle)	50	50	50	50	A ² sec
R _{jb}	3.0	2.2	3.0	2.2	°C/W

GENERAL SPECIFICATIONS:

Parameter	All Devices
Operating Temperature Range	-20 to 80°C
Storage Temperature Range	-40 to 100°C
Input to Output Isolation Voltage (8)	4000 Vrms
I/O to Ground Isolation Voltage (8)	2500 Vrms
Capacitance (Input to Output)	8 pF
Line Frequency Range	47 to 63 Hz

Notes:

- (1) At 15Vdc.
- (2) Do not apply continuously for over 1 minute.
- (3) At maximum rated voltage.
- (4) Mounted in free air, T_a = 45°C.
- (5) Non-repetitive 60 Hz, Resistive load, T_a = 25°C.
- (6) Non-repetitive 50 or 60 Hz, Resistive load, T_a = 25°C.
- (7) At maximum rated current.
- (8) Limited to 1 mA for 1 second, T_a = 25°C.
- (9) Input current is 63 mA Max.

Products and specifications subject to change without notice.

Order/Technical Support – Tel: (800) 677-5311 / FAX: (800) 677-3865 / www.crouzet-usa.com

SIMM Series Input Relays

- ▶ 6.2 mm wide and 65 mm deep
- ▶ DIN Rail mounted
- ▶ LED input status indicator
- ▶ Bridges enable quick linking of common voltage
- ▶ Identification zone on front face
- ▶ IP20

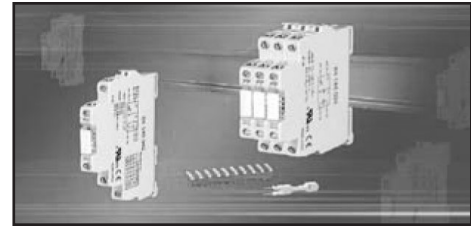

Part Numbers

	84145061	84145062	84145064	84145066	84145071
Input Characteristics (at ambient 25 C°)					
Nominal voltage	24Vdc	24Vac/dc	120	240	5 - 28
Operating voltage range	19.2-30Vdc	19.2-30Vac/dc	95-121Vac/dc	195-253Vac/dc	19.2-30Vac/dc
Max. input current	20 mA	20 mA	5 mA	5 mA	20 mA
Output Characteristics (at ambient 25 C°)					
Max Voltage	30Vac/36Vdc	30Vac/36Vdc	30Vac/36Vdc	30Vac/36Vdc	30Vac/36Vdc
Max current	50 mA	50 mA	50 mA	50 mA	50 mA
General Characteristics					
Operating temperature range	-25 to 60°C	-25 to 60°C	-25 to 60°C	-25 to 60°C	-25 to 60°C
Storage temperature range	-40 to 80°C	-40 to 80°C	-40 to 80°C	-40 to 80°C	-40 to 80°C
Turn-On time	8 ms	8 ms	8 ms	8 ms	8 ms
Turn-Off time	10 ms	10 ms	10 ms	10 ms	10 ms
Switching frequency	10 Hz	10 Hz	10 Hz	10 Hz	10 Hz
Mechanical Life (operations)	>10 x 10 ⁶	>10 x 10 ⁶	>10 x 10 ⁶	>10 x 10 ⁶	>10 x 10 ⁶
Electrical Life (number of operation)	6 x 10 ⁶	6 x 10 ⁶	6 x 10 ⁶	6 x 10 ⁶	6 x 10 ⁶
Weight	1.23 oz	1.23 oz	1.23 oz	1.23 oz	1.23 oz
Contact Material	AgSnO ₂ gold plated				
Contact Arrangement	SPDT	SPDT	SPDT	SPDT	SPST (N.O.)

Note: Exceeding the value given for the output relay current will remove the gold plating from the contacts and therefore we cannot guarantee correct operation at low currents.

Dimensions:

SPDT

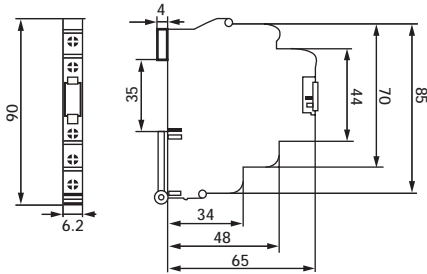

SPST

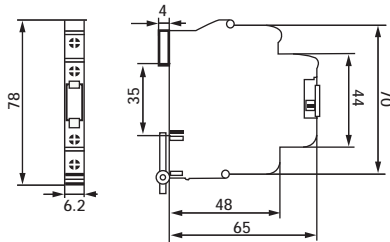

Wiring Diagram and Thermal Curves:

84145061 / 062 / 064 / 066

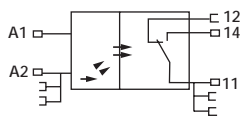

84145071

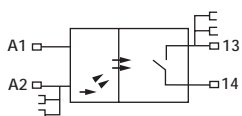

Accessories

84145050

Front Panel marker (88 per bag)

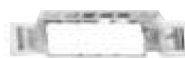

84145052

10 position jumper - Blue



84145051

2 Pole "Common" Jumper



84145053

10 position jumper - Red



Products and specifications subject to change without notice.

Order/Technical Support – Tel: (800) 677-5311 / FAX: (800) 677-3865 / www.crouzet-usa.com

SIMM Series Output Relays

- ▶ 6.2 mm wide and 65 mm deep
- ▶ DIN Rail mounted
- ▶ LED input status indicator
- ▶ Bridges enable quick linking of common voltage
- ▶ Identification zone on front face
- ▶ IP20

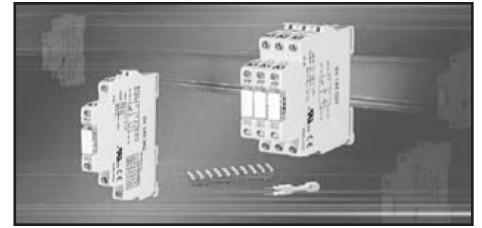

Part Numbers

	84145001	84145004	84145005	84145010	84145011	84145015
Input Characteristics (at ambient 25 C°)						
Nominal voltage	24Vdc	110Vac/dc	230Vac	5Vdc	24Vdc	230Vac
Operating voltage range	10-44Vdc	70-130Vac/dc	90-230Vac	4-5.5Vdc	10-44Vdc	90-230Vac
Max. input current	6 mA	7 mA	8.5 mA	6 mA	6 mA	7 mA
Drop out voltage	5Vdc	30Vac/dc	40Vac	2Vdc	3Vdc	40Vac
Output Characteristics (at ambient 25 C°)						
Operating voltage range	5-48Vdc	5-48Vdc	5-48Vdc	5-48Vdc	5-48Vdc	5-48Vdc
Max current	0.5A	0.5A	0.5A	2A	2A	2A
Output Type	Transistor	Transistor	Transistor	Transistor	Transistor	Transistor
General Characteristics						
Operating temperature range	-20 to 60°C	-20 to 60°C	-20 to 60°C	-20 to 60°C	-20 to 60°C	-20 to 60°C
Storage temperature range	-40 to 80°C	-40 to 80°C	-40 to 80°C	-40 to 80°C	-40 to 80°C	-40 to 80°C
Turn-On time	20 us	30 ms	45 ms	1 ms	1 ms	1 ms
Turn-Off time	100 us	20 ms	15 ms	5 ms	5 ms	10 ms
Switching frequency	1k Hz	10 Hz	10 Hz	10 Hz	10 Hz	10 Hz
Weight	1.13 oz	1.13 oz	1.13 oz	1.06 oz	1.06 oz	1.06 oz

Part Numbers

	84145020	84145021	84145024	84145025	84145031
Input Characteristics (at ambient 25 C°)					
Nominal voltage	5Vdc	24Vdc	110Vac/dc	230Vac	24Vdc
Operating voltage range	4-6.2Vdc	10-44Vdc	70-130Vac/dc	140-250Vac	10-44Vdc
Max. input current	6 mA	6 mA	6 mA	7 mA	6 mA
Drop out voltage	2Vdc	3Vdc	35Vac/dc	80Vac	3Vdc
Output Characteristics (at ambient 25 C°)					
Operating voltage range	24-250Vac	24-250Vac	24-250Vac	24-250Vac	24-250Vac
Max current	0.5A	0.5A	0.5A	0.5A	1A
Output Type	Triac	Triac	Triac	Triac	Triac
General Characteristics					
Operating temperature range	-20 to 60°C	-20 to 60°C	-20 to 60°C	-20 to 60°C	-20 to 60°C
Storage temperature range	-40 to 80°C	-40 to 80°C	-40 to 80°C	-40 to 80°C	-40 to 80°C
Turn-On time	10 ms	10 ms	10 ms	10 ms	8.33 ms
Turn-Off time	10 ms	10 ms	10 ms	10 ms	8.33 ms
Switching frequency	20 Hz	20 Hz	20 Hz	20 Hz	20 Hz
Weight	1.13 oz	1.13 oz	1.13 oz	1.13 oz	.95 oz

Derating Curves:

84145001 / 004 / 005
84145010 / 011 / 015

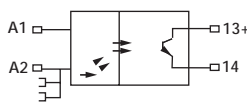

84145010 / 011 / 015

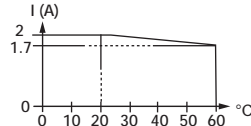

84145031

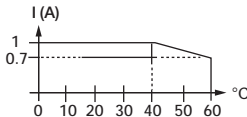

84145001 / 004 / 005
84145020 / 021 / 024 / 025

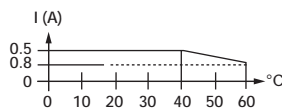

84145020 / 021 / 024 / 025

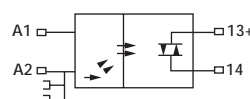

84145031

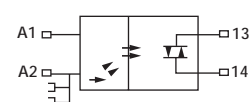

Dimensions:

Solid State Output:

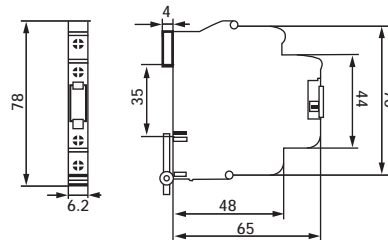

Products and specifications subject to change without notice.

Order/Technical Support – Tel: (800) 677-5311 / FAX: (800) 677-3865 / www.crouzet-usa.com

SIMM Series Output Relays

- ▶ 6.2 mm wide and 65 mm deep
- ▶ DIN Rail mounted
- ▶ LED input status indicator
- ▶ Bridges enable quick linking of common voltage
- ▶ Identification zone on front face
- ▶ IP20

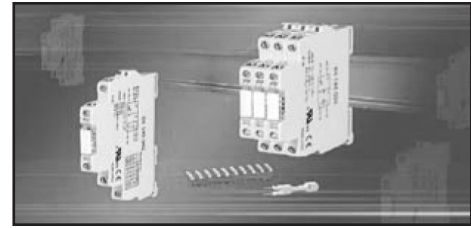

Part Numbers

	84145041	84145042	84145043	84145046
Input Characteristics (at ambient 25 C°)				
Nominal voltage	24Vdc	24Vac/dc	110Vac/dc	230Vac
Operating voltage range	19.2-30Vdc	19.2-30Vac/dc	95-125Vac/dc	195-253Vac/dc
Max. input current	20 mA	20 mA	5 mA	6
Output Characteristics (at ambient 25 C°)				
Operating voltage range	1-250Vac	1-250Vac	1-250Vac	1-250Vac
Max current	6 A	6 A	6 A	6 A
General Characteristics				
Operating temperature range	-25 to 60°C	-25 to 60°C	-25 to 60°C	-25 to 60°C
Storage temperature range	-40 to 80°C	-40 to 80°C	-40 to 80°C	-40 to 80°C
Turn-On time	8 ms	8 ms	8 ms	8 ms
Turn-Off time	10 ms	10 ms	10 ms	10 ms
Switching frequency	10 Hz	10 Hz	10 Hz	10 Hz
Mechanical Life (operations)	>10 x 10 ⁶	>10 x 10 ⁶	>10 x 10 ⁶	>10 x 10 ⁶
Electrical Life (number of operation)	6 x 10 ⁶	6 x 10 ⁶	6 x 10 ⁶	6 x 10 ⁶
Weight	1.23 oz	1.23 oz	1.23 oz	1.23 oz
Contact Material	AgSnO ₂			
Contact Arrangement	SPDT	SPDT	SPDT	SPDT

Dimensions:

Relay Output:

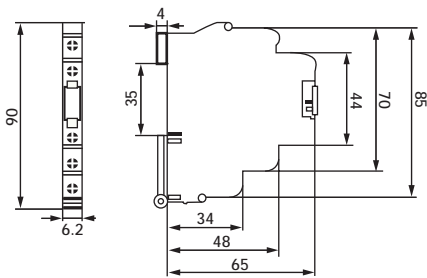

Wiring Diagram and Thermal Curves:

84145041 / 042 / 043 / 046

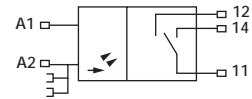
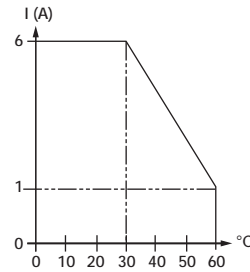

Accessories

84145050

Front Panel marker (88 per bag)

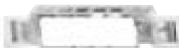

84145052

10 position jumper - Blue



84145051

2 Pole "Common" Jumper



84145053

10 position jumper - Red



Products and specifications subject to change without notice.

Order/Technical Support – Tel: (800) 677-5311 / FAX: (800) 677-3865 / www.crouzet-usa.com

Hybrid Power Relay – RHP (Single Pole Relay)

- 20 Amp output (Resistive only)
- Every SSR advantage without the drawbacks
- Lifetime > 5 million operations full load
- Noiseless
- Functions: contactor – bistable
- 17.5 mm DIN rail mount
- UL/cUL (listed)
- Label NF-USE
- CE compliant

Operation:

Contactor

Output of the contactor is closed when the input is On.
Output of the contactor is opened when the input is Off.
Led is On when the output is closed.

Bistable Relay

Output of the bistable changes of status for every pulse on the input and stays in its position between pulses.
Front plate push button allows to select the operation mode:
Stop – led off – output off
On forced – led flashing – output on
Auto – led on – bistable relay operation

Day/night contactor

Output of the contactor is closed when the input is On
Output of the contactor is opened when the input is Off.
Front plate push button allows to select the operation mode:
Stop – led off – output off
On forced – led flashing – output on – back to the Auto mode at the next change of the input.
Auto – led on – day/night contactor operation

Compliance

CEI/EN 60947-4-3 (industrial environment)
CEI/EN 60669-2-1 (household environment)
CEI/EN 60601-1 (medical environment)
CEI/EN 60947-7-1 (connections in industrial env.)
CEI/EN 60998-2-1 (connections in household env.)

Insulation:

Installation category: 3
pollution: 3
CEI60664-1: 4KV/3
dielectric CEI/EN 60669-2-1:
2 KV/1mm / 1mA / 50 Hz
Insulation CEI/EN 60669-2-1:
> 5MΩ/500VDC / 1 min
Vibrations CEI/EN 60068-2-6: frequencies: 10 to 55 Hz
magnitude: 0,35 mm

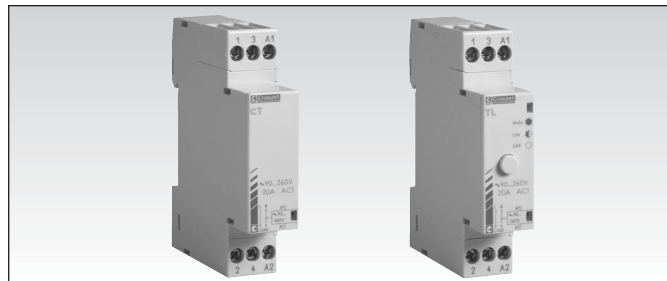
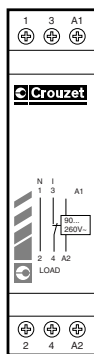
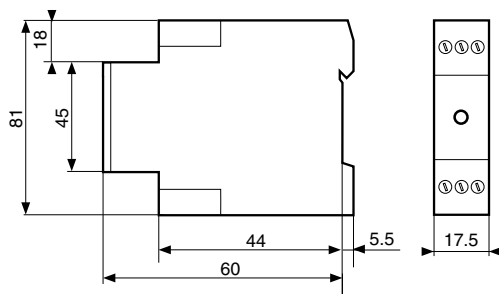

Type

Part number

AC input contactor	84 138 001
DC input contactor	84 138 000
AC input distable relay	84 138 101
AC input day/night contactor	84 138 201

Specifications

Power supply	90-260 Vac
Frequency	50 / 60 Hz
Max. power consumption	11 VA

Input Control

Voltage	90-260 Vac	0-32 Vdc
Frequency	50 / 60 Hz	
Value		
Input OFF	0 – 46 Vac	0 – 1 Vdc
Input ON	76 – 260 Vac	4 – 32 Vdc
Min. time input	50 ms	50 ms

Output

Voltage	90-260 Vac
Max. current	20A in AC1 / AC51 / AC7a
Overload current 20A	AC-51: 1,25 x Ie – 60s: 50 – 30 (CEI 60947-4-3)
Min current	100mA in AC1 / AC51 / AC7a
Frequency	50 / 60 Hz
Contact	N.O.
Switching frequency	6 / min
lifetime	> 5,000,000
leakage current	< 5 mA
Acoustic noise	
ON position	< 35 dB @ 1m
switching	< 50 dB @ 0.5m
terminal capacity	2 x 2.5 mm2 without ferrule
	1 x 4 mm2 without ferrule
Torque	1Nm maxi. screw M3 (CEI 60947-1)

Operating temperature:	-5°C to +55°C
Storage temperature	-40°C to +85°C
Humidity	90 to 95% non-condensing
Housing	self extinguish
protection (CEI 60529)	housing IP 50 terminal IP 20

weight	70 gr
--------	-------

Products and specifications subject to change without notice.

Order/Technical Support – Tel: (800) 677-5311 / FAX: (800) 677-3865 / www.crouzet-usa.com

SOLID STATE RELAYS

22.5mm DIN-RAIL SSR

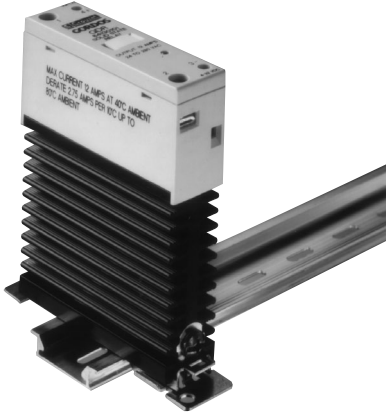

FEATURES:

- DIN-Rail or panel mount.
- Compact Size.
- LED indicator.
- AC or DC control.
- Zero AC turn-on models.
- 12 and 25 Amp Outputs
- UL, cUL Recognized (25 Amp Model: UL Rating 20 Amps)
 12 Amp .5 HP @ 240 VAC
 20 Amp 1.5 HP @ 240 VAC
- CE Compliant Per EN60950
- UL E79183

EQUIVALENT CIRCUIT

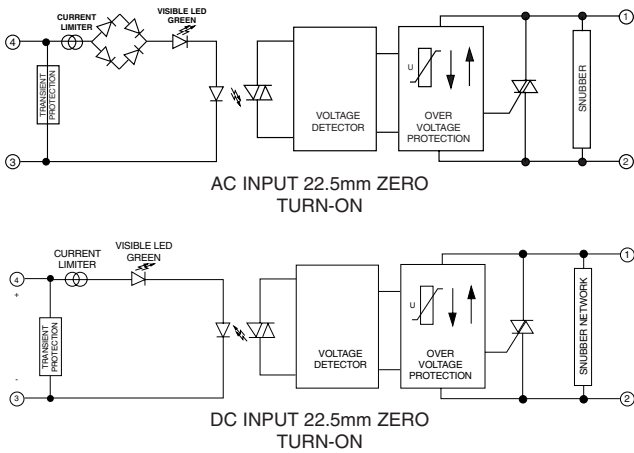

DIMENSIONS: inches (mm)

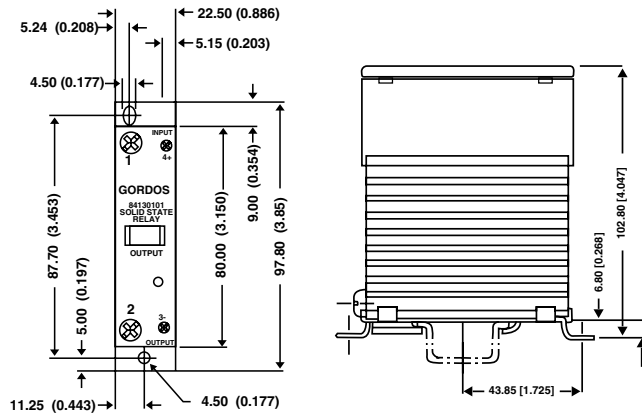

DERATE CURVES: 22.5mm Din Rail SSR

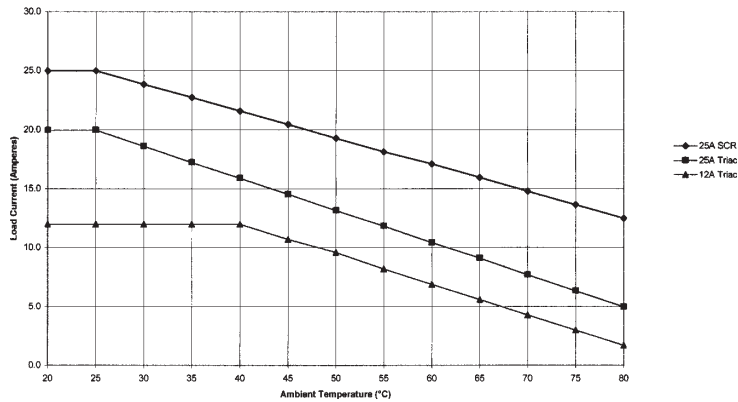

Products and specifications subject to change without notice.

Order/Technical Support – Tel: (800) 677-5311 / FAX: (800) 677-3865 / www.crouzet-usa.com

SOLID STATE RELAYS

22.5mm DIN-RAIL SSR

INPUT SPECIFICATIONS:

	84130101	84130150	84130100	84130117	
Model Number	84130103	84130152	84130102		
Parameter	84130116	84130158	84130118		Units
Control Voltage	4-32 VDC	90-140 VAC	180-280 VAC	4-32 VDC	
Drop Out Voltage	1.0 VDC	10 VAC	10 VAC	1.0 VDC	
Maximum Input Current (1)	12	6	6	12	mA
Maximum Turn-On Time	8.33	20	20	0.1	ms
Maximum Turn-Off Time	8.33	30	30	8.33	ms
Type	Zero Crossing	Zero Crossing	Zero Crossing	Random Turn-on	
Wire Size	0.00"-0.078"	0.00"-0.078"	0.00"-0.078"	0.00"-0.078"	

OUTPUT SPECIFICATIONS:

	84130100	84130102	84130116	
Model Number	84130101	84130103	84130117	
Parameter	84130150	84130152	84130118	Units
Line Voltage	24-280	24-280	48-660	V _{ms}
Peak Off-State Voltage (2)	600	800	1200	V _{peak}
Maximum Off-State Leakage (3)	.1	.1	.25	mArms
Static Off-State dv/dt (4)	200	600	500	V/μSec
Minimum On-State Current	100	100	100	mArms
Maximum On-State Current (5)	12	20	25	Arms
Maximum 1-Cycle Surge (6)	250	400	250	A _{peak}
Maximum 1-Second Surge (7)	60	140	75	A _{peak}
Peak On-State Voltage Drop (8)	1.85	1.8	1.6	V _{peak}
I ² t (60 Hz, Half-Cycle)	260	600	260	A ² sec
Output Type	TRIAC	ALTERNISTOR	B/B SCR	
Wire Size	0.20"-0.078"	0.20"-0.078"	0.20"-0.078"	

GENERAL SPECIFICATIONS:

Parameter	All Devices
Operating Temperature Range	-20 to 80°C
Storage Temperature Range	-40 to 100°C
Input to Output Isolation Voltage (9)	4000 Vrms
Input/Output to Ground Isolation Voltage (9)	2500 Vrms
Capacitance (Input to Output)	8 pF
Line Frequency Range	47 to 63 Hz

Notes:

- (1) At maximum input voltage. Input is regulated and current limited.
- (2) Do not apply continuously for over 1 minute.
- (3) At maximum line voltage, T_a = 25°C.
- (4) Minimum dv/dt per EIA/NARM R5443, method RS397, 25°C.
- (5) Mounted in vertical position on DIN-Rail. Free Air.
- (6) Non-repetitive 60 Hz, resistive load, T_a = 25°C.
- (7) Non-repetitive 50 or 60 Hz, resistive load, T_a = 25°C.
- (8) At maximum rated current.
- (9) Limited to 1 mA for 1 second, T_a = 25°C.

Products and specifications subject to change without notice.

Order/Technical Support – Tel: (800) 677-5311 / FAX: (800) 677-3865 / www.crouzet-usa.com

SOLID STATE RELAYS

45mm DIN-RAIL SSR



FEATURES:

- DIN-Rail or Panel Mount.
- Compact Size.
- LED Indicator.
- AC or DC Control.
- Zero AC or Random turn-on models.
- 35 and 45 Amp Outputs.
- 4 kV Optical Isolation.
- CE Compliant Per EN60950
- UL, cUL Recognized E79183

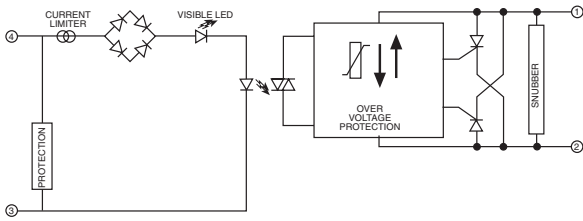

AC 45mm THREE PHASE
AC INPUT
EQUIVALENT CIRCUIT

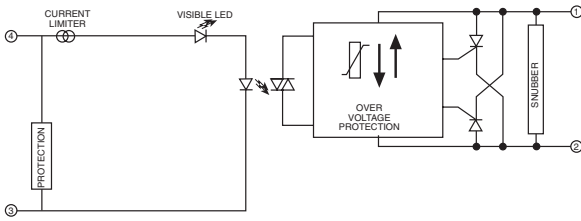

DC 45mm THREE PHASE RANDOM
DC INPUT
EQUIVALENT CIRCUIT

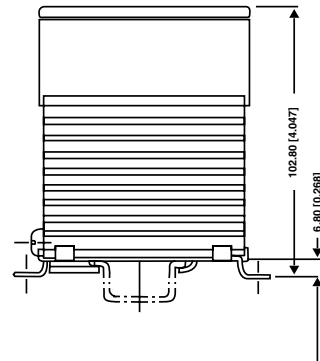
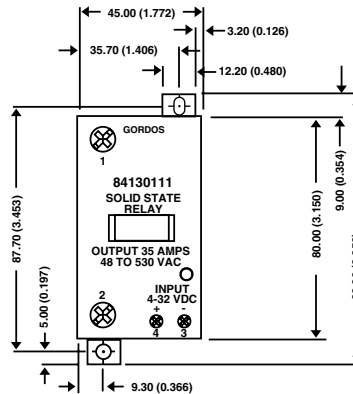

Products and specifications subject to change without notice.

Order/Technical Support – Tel: (800) 677-5311 / FAX: (800) 677-3865 / www.crouzet-usa.com

SOLID STATE RELAYS

INPUT SPECIFICATIONS:

Model Number	84130111	84130112	84130110	
Parameter	84130113	84130114	84130115	Units
Control Voltage	4-32 VDC	4-32 VDC	90-280 VAC	
Drop Out Voltage	1.0 VDC	1.0 VDC	10 VAC	
Maximum Input Current (1)	10	10	6	mA
Maximum Turn-On Time	8.33	0.1	20	ms
Maximum Turn-Off Time	8.33	8.33	30	ms
Type	Zero Crossing	Random Turn-on	Zero Crossing	
Wire Size	.020"-.078"	.020"-.078"	.020"-.078"	

OUTPUT SPECIFICATIONS:

Model Number	84130110	84130113		
	84130111	84130114		
	84130112	84130115		Units
Line Voltage	48-530	48-530		Vrms
Peak Off-State Voltage (2)	1200	1200		Vpeak
Maximum Off-State Leakage (3)	.25	.25		mArms
Static Off-State dv/dt (4)	500	500		V/μSec
Minimum On-State Current	100	100		mArms
Maximum On-State Current (5)	35	45		Arms
Maximum 1-Cycle Surge (6)	750	750		Apeak
Maximum 1-Second Surge (7)	145	145		Apeak
Peak On-State Voltage Drop (8)	1.6	1.6		Vpeak
I ² t (60Hz, Half-Cycle)	1000	1000		A ² sec
Wire Size	.040"-.220"	.040"-.220"		

GENERAL SPECIFICATIONS:

Parameter	All Devices
Operating Temperature Range	-20 to 80°C
Storage Temperature Range	-40 to 100°C
Input to Output Isolation Voltage (9)	4000 Vrms
I/O to Ground Isolation Voltage (9)	2500 Vrms
Capacitance (Input to Output)	8 pF
Line Frequency Range	47 to 63 Hz

Notes:

- (1) At maximum input voltage. Input is regulated and current limited.
- (2) Do not apply continuously for over 1 minute.
- (3) At maximum line voltage, Ta = 25°C.
- (4) Minimum dv/dt per EIA/NARM R5443, method RS397, 25°C.
- (5) Mounted in vertical position on DIN-Rail. Free Air.
- (6) Non-repetitive 60 Hz, resistive load, Ta = 25°C.
- (7) Non-repetitive 50 or 60 Hz, resistive load, Ta = 25°C.
- (8) At maximum rated current.
- (9) Limited to 1 mA for 1 second, Ta = 25°C.

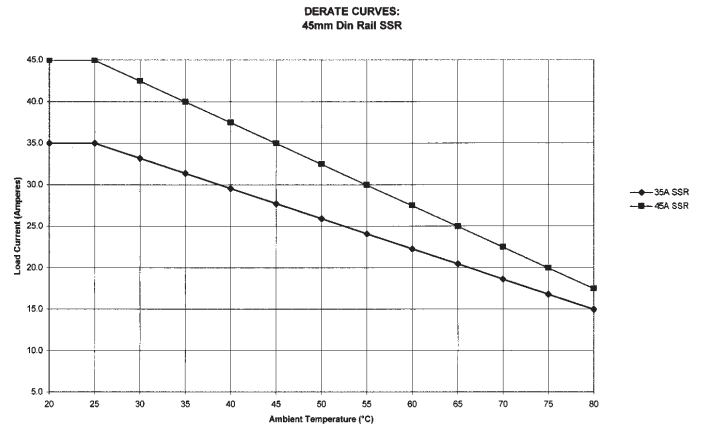

Products and specifications subject to change without notice.

Order/Technical Support – Tel: (800) 677-5311 / FAX: (800) 677-3865 / www.crouzet-usa.com

SOLID STATE RELAYS

90mm 2 and 3 PHASE DIN-RAIL SSR

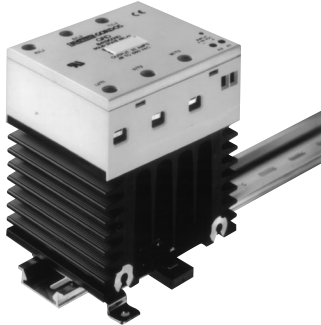

FEATURES:

- DIN-Rail or panel mount.
- Compact Size.
- LED indicator.
- AC or DC control.
- Zero AC or random turn-on models.
- 4 kV optical isolation.
- UL, cUL Recognized (File E79183)
- CE Compliant Per EN60950

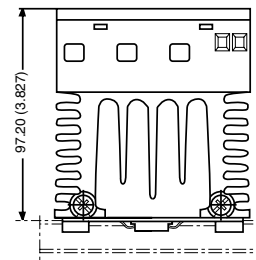
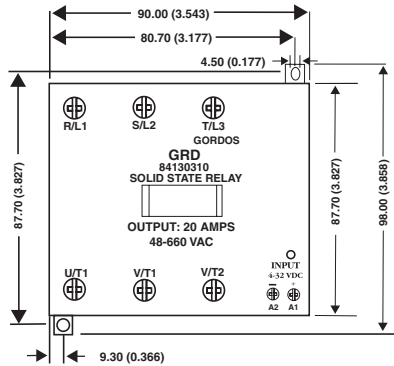

DIMENSIONS: inches (mm)
TOLERANCE: ±0.20 (±0.008)

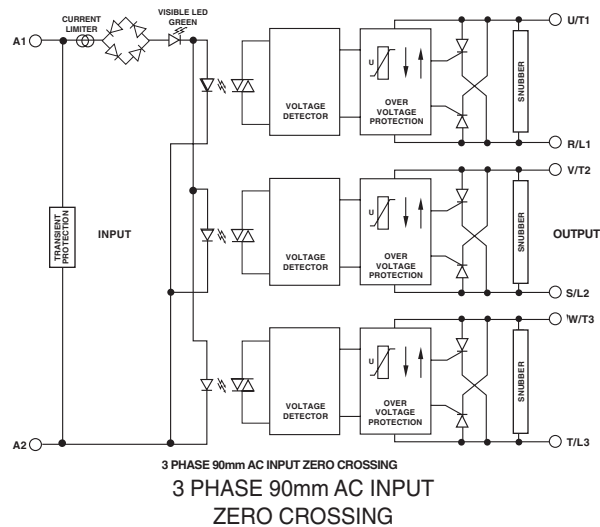
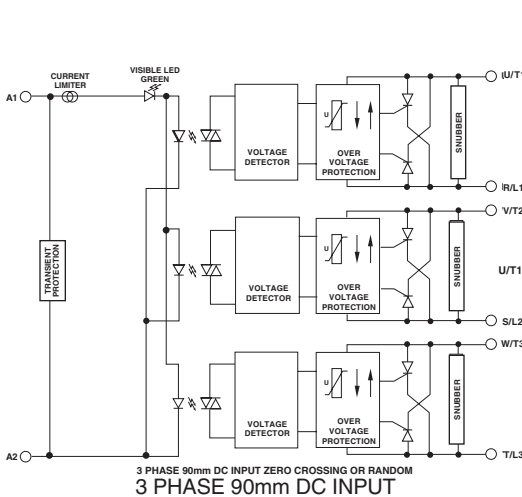

NOTE: V/T2 to S/L2 is shorted on 2 phase models.

Products and specifications subject to change without notice.

Order/Technical Support – Tel: (800) 677-5311 / FAX: (800) 677-3865 / www.crouzet-usa.com

SOLID STATE RELAYS

90mm 2 and 3 PHASE DIN-RAIL SSR

INPUT SPECIFICATIONS:

Model Number	84130310	84130312	84130311	Units
Parameter	84130220	84130221	84130222	
Control Voltage	4-32 VDC	4-32 VDC	90-280 VAC	
Drop Out Voltage	1.0 VDC	1.0 VDC	10 VAC	
Maximum Input Current (1)	22	22	6	mA
Maximum Turn-On Time	8.33	0.1	20	ms
Maximum Turn-Off Time	8.33	8.33	30	ms
Type	Zero Crossing	Random Turn-on	Zero Crossing	

OUTPUT SPECIFICATIONS:

Model Number	Three Phase	Two Phase	Units
	84130310 84130311 84130312	84130220 84130221 84130222	
Parameter			
Line Voltage	48-530	48-530	Vrms
Peak Off-State Voltage (2)	1200	1200	Vpeak
Maximum Off-State Leakage (3)	.25	.25	mArms
Static Off-State dv/dt (4)	500	500	V/μSec
Minimum On-State Current	100	100	mArms
Maximum On-State Current per phase (5)	20	25	Arms
Maximum 1-Cycle Surge (6)	750	750	Apeak
Maximum 1-Second Surge (7)	145	145	Apeak
Peak On-State Voltage Drop (8)	1.6	1.6	Vpeak
I ² t (60 Hz, Half-Cycle)	1000	1000	A ² sec

GENERAL SPECIFICATIONS:

Parameter	All Devices
Operating Temperature Range	-20 to 80°C
Storage Temperature Range	-40 to 100°C
Input to Output Isolation Voltage (9)	4000 Vrms
Input/Output to ground Isolation Voltage (9)	2000 Vrms
Capacitance (Input to Output)	8 pF
Line Frequency Range	47 to 63 Hz

Notes:

- (1) At maximum input voltage. Input is regulated and current limited.
- (2) Do not apply continuously for over 1 minute.
- (3) At maximum line voltage, Ta = 25°C.
- (4) Minimum dv/dt per EIA/NARM R5443, method RS397, 25°C.
- (5) Mounted in vertical position on DIN-Rail. Free Air. Derated by 27.3 mA/°C to 80°C.
- (6) Non-repetitive 60 Hz, resistive load, Ta = 25°C.
- (7) Non-repetitive 50 or 60 Hz, resistive load, Ta = 25°C.
- (8) At maximum rated current.
- (9) Limited to 1 mA for 1 second, Ta = 25°C.

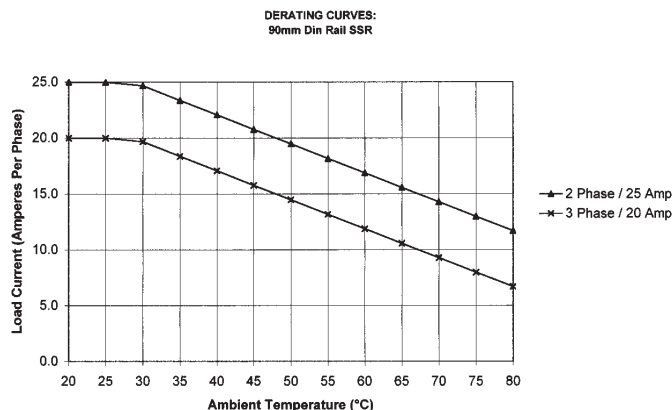

Products and specifications subject to change without notice.

Order/Technical Support – Tel: (800) 677-5311 / FAX: (800) 677-3865 / www.crouzet-usa.com



Products and specifications subject to change without notice.

Order/Technical Support – Tel: (800) 677-5311 / FAX: (800) 677-3865 / www.crouzet-usa.com

SOLID STATE RELAY ACCESSORIES

THERMAL PADS

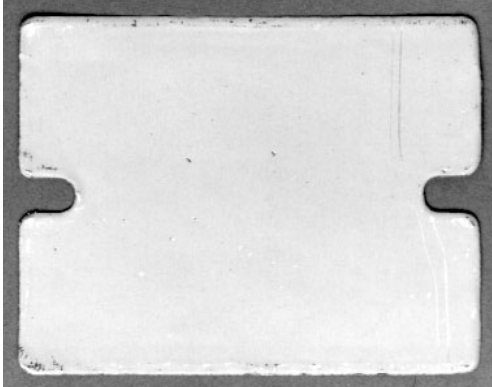

HSP1
Series: Single Phase



HSP3
Series: Three Phase
GAO and GA3

HSP1 for Single Phase Relay.
HSP3 for 3 phase **GAO** Series and **GA3** Series.
Sold in multiples of 25 (1 package) per part number.

®Thermstrate is a registered Trademark of Power Devices, Inc.

Solid State Relay Cover



FEATURES:

- Snaps onto Crouzet Single Phase SSRs
- Provides "Finger Safe Operation" of SSRs
- Made of High Impact, Flame Retardant Polycarbonate.

ORDERING INFORMATION:

Model #	Description
84136500	Solid State Relay Cover

Products and specifications subject to change without notice.

Order/Technical Support – Tel: (800) 677-5311 / FAX: (800) 677-3865 / www.crouzet-usa.com

SOLID STATE RELAY ACCESSORIES

HS2 HEATSINK

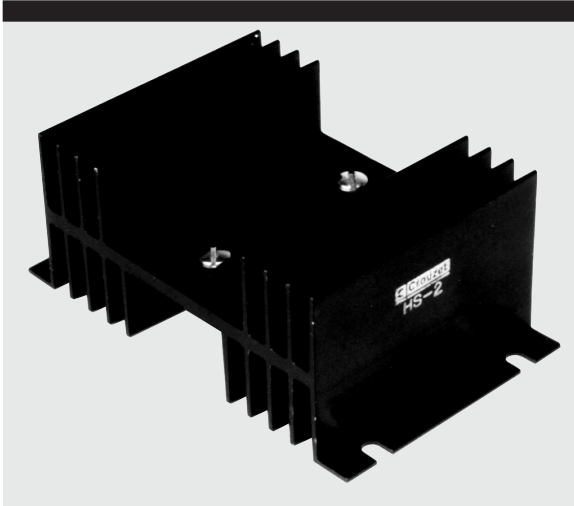

ORDERING INFORMATION:

Model #	Description
HS2	Heatsink 2.0°C/W (For Single Phase SSR's)

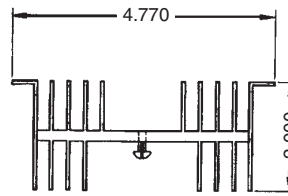

DIMENSIONS: inches
TOLERANCES: ±0.02 inches
MATERIAL: AISI 6063-T5 Aluminum
FINISH: Black Anodized

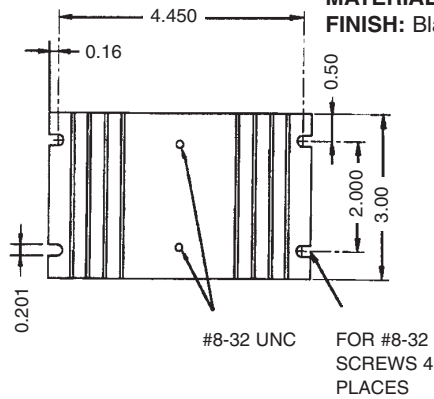

SOLID STATE RELAY ACCESSORIES

HS3 HEATSINK

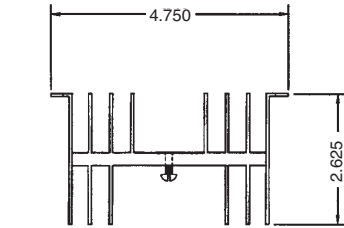
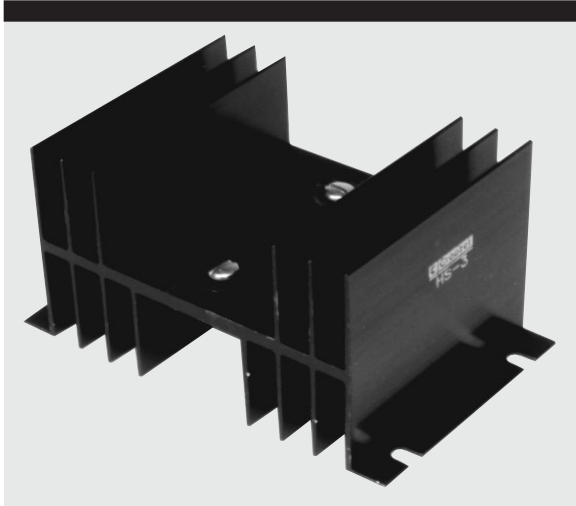

DIMENSIONS: inches
TOLERANCES: ±0.02 inches
MATERIAL: AISI 6063-T5 Aluminum
FINISH: Black Anodized

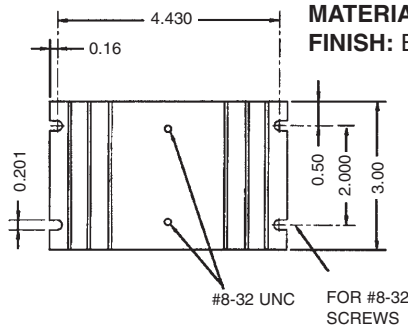

ORDERING INFORMATION:

Model #	Description
HS3	Heatsink 1.5°C/W (For Single Phase SSR's)

HS13 HEATSINK

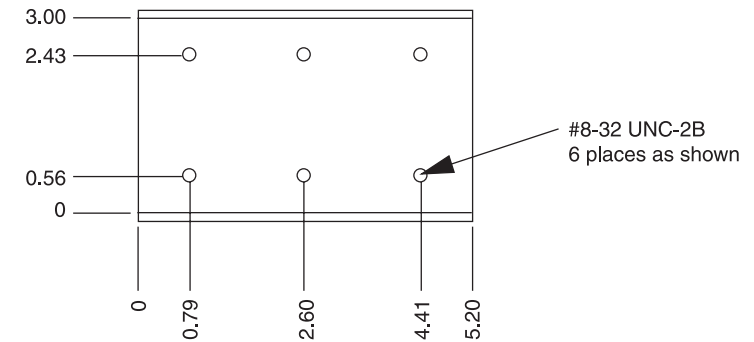
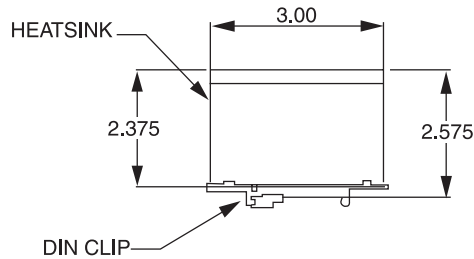
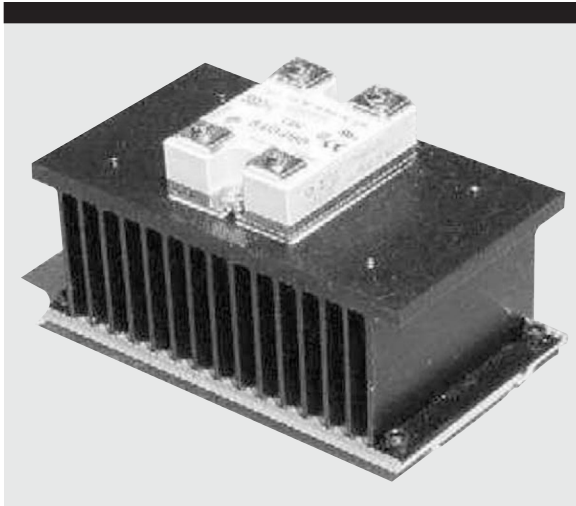

ORDERING INFORMATION:

Model #	Description
HS13	Heatsink 0.8°C/W (For Single Phase and Three Phase SSR's)

DIMENSIONS: inches
TOLERANCES: ±0.02 inches
MATERIAL: AISI 6063-T5 Aluminum
FINISH: Black Anodized

Products and specifications subject to change without notice.

Order/Technical Support – Tel: (800) 677-5311 / FAX: (800) 677-3865 / www.crouzet-usa.com

SOLID STATE RELAY ACCESSORIES

HS5 HEATSINK

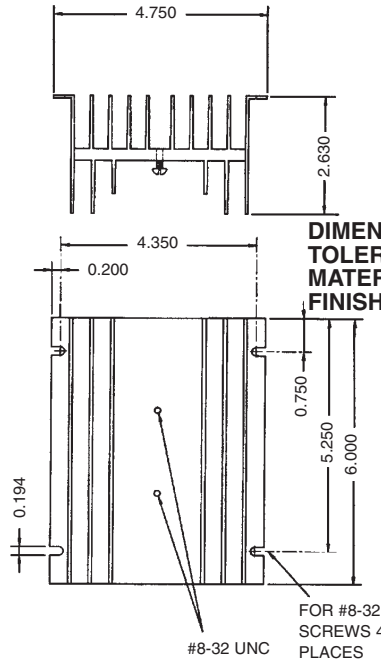

DIMENSIONS: inches
TOLERANCES: ± 0.02 inches
MATERIAL: AISI 6063-T5 Aluminum
FINISH: Black Anodized

ORDERING INFORMATION:

Model #	Description
HS5	Heatsink 0.7°C/W (For Single Phase SSR's)

HS6 HEATSINK

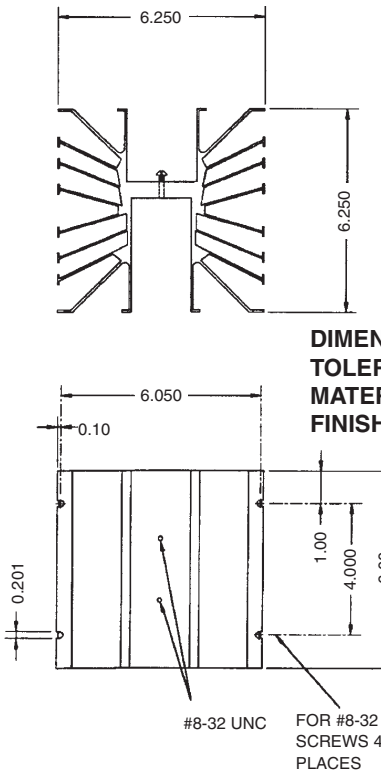
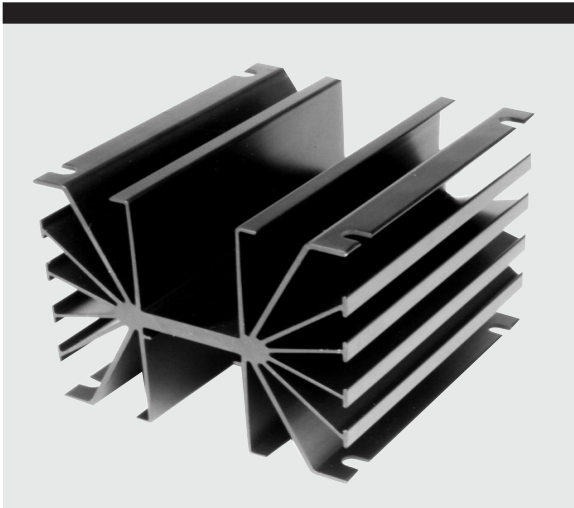

DIMENSIONS: inches
TOLERANCES: ± 0.02 inches
MATERIAL: AISI 6063-T5 Aluminum
FINISH: Black Anodized

ORDERING INFORMATION:

Model #	Description
HS6	Heatsink 0.5°C/W (For Single Phase SSR's)

Products and specifications subject to change without notice.

Order/Technical Support – Tel: (800) 677-5311 / FAX: (800) 677-3865 / www.crouzet-usa.com

SOLID STATE RELAYS

HS7 HEATSINK

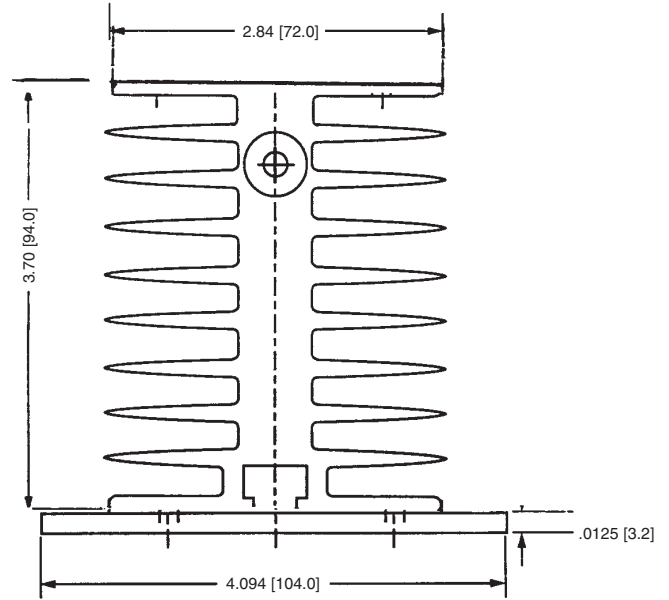
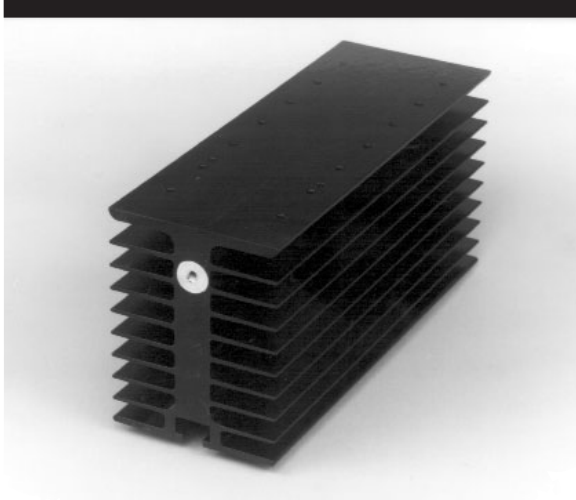

ORDERING INFORMATION:

Model #	Description
HS7	Heatsink 0.9°C/W (For GA3 Series SSR's)

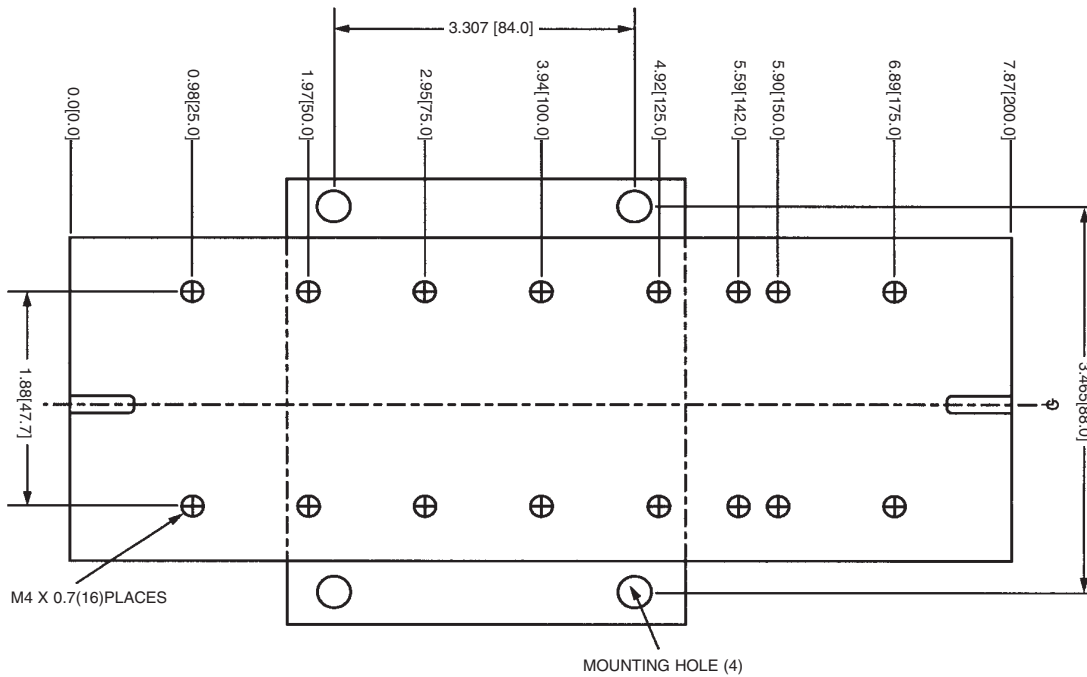

DIMENSIONS: inches (mm)
TOLERANCES: ±0.02 inches
MATERIAL: AISI 6063-T5 Aluminum
FINISH: Black Anodized

Products and specifications subject to change without notice.

Order/Technical Support – Tel: (800) 677-5311 / FAX: (800) 677-3865 / www.crouzet-usa.com

SOLID STATE RELAYS

HS8 HEATSINK

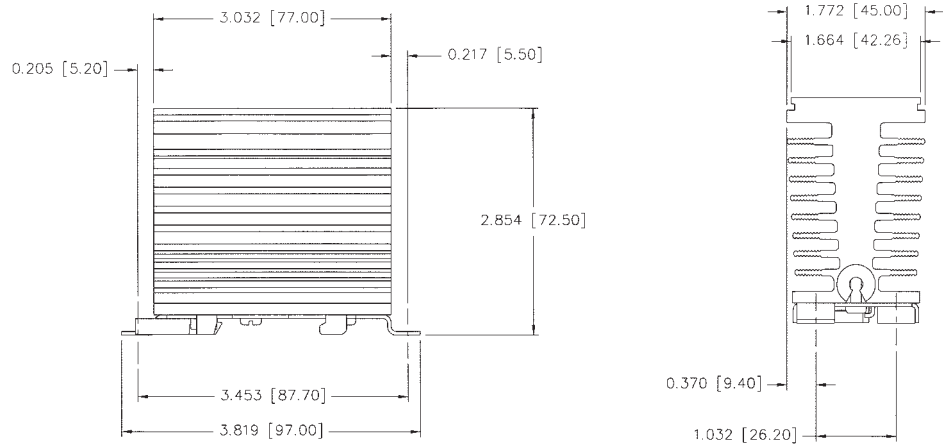

ORDERING INFORMATION:

Model #	Description
HS8	Heatsink 2.1°C/W (For Single Phase SSR's)

HS9 HEATSINK

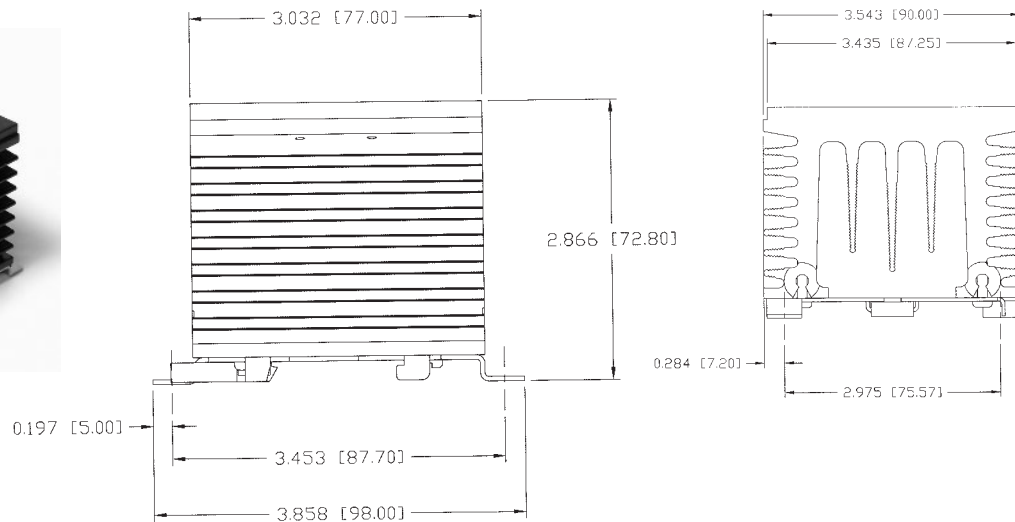

ORDERING INFORMATION:

Model #	Description
HS9	Heatsink 1.5°C/W (For Single Phase SSR's)

DIMENSIONS: inches (mm)

TOLERANCES: ±0.02 inches

MATERIAL: AISI 6063-T5 Aluminum

FINISH: Black Anodized

Products and specifications subject to change without notice.

Order/Technical Support – Tel: (800) 677-5311 / FAX: (800) 677-3865 / www.crouzet-usa.com

SOLID STATE RELAYS

HS10 HEATSINK

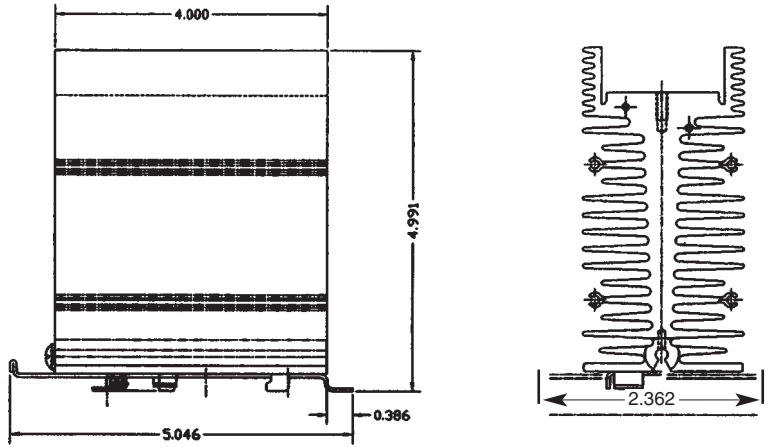
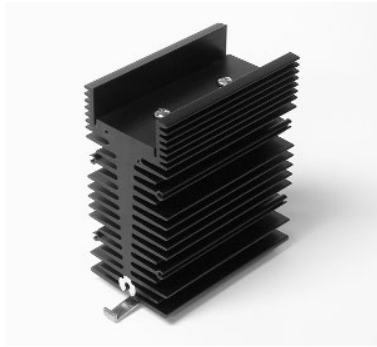

ORDERING INFORMATION:

Model #	Description
HS10	Heatsink 1.1°C/W (For Single Phase SSR's)

HS12 HEATSINK

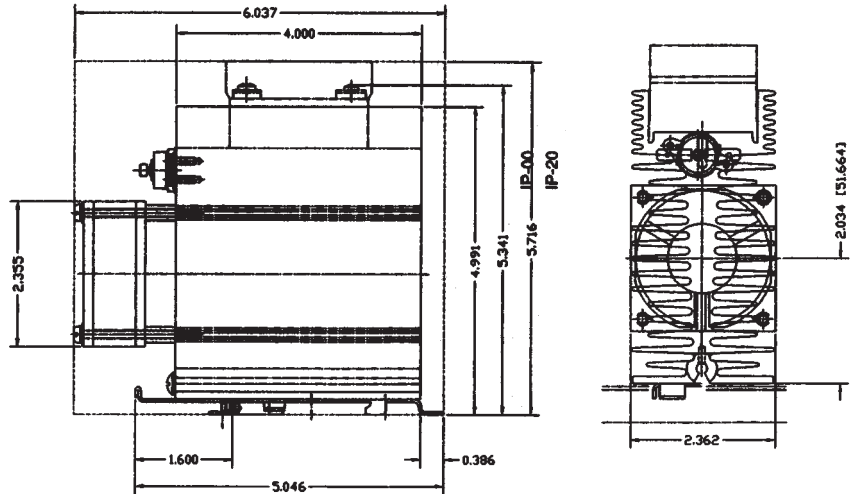
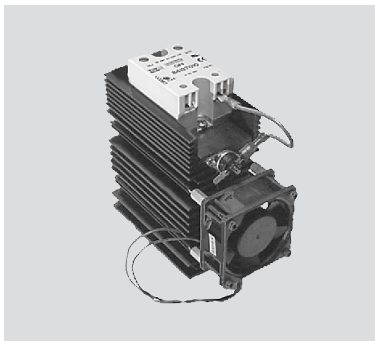

(Relay Optional)

ORDERING INFORMATION:

Model #	Description
HS12	Heatsink 0.55°C/W (For Single Phase SSR's)

DIMENSIONS: inches (mm)
TOLERANCES: ±0.02 inches
MATERIAL: AISI 6063-T5 Aluminum
FINISH: Black Anodized

Products and specifications subject to change without notice.

Order/Technical Support – Tel: (800) 677-5311 / FAX: (800) 677-3865 / www.crouzet-usa.com

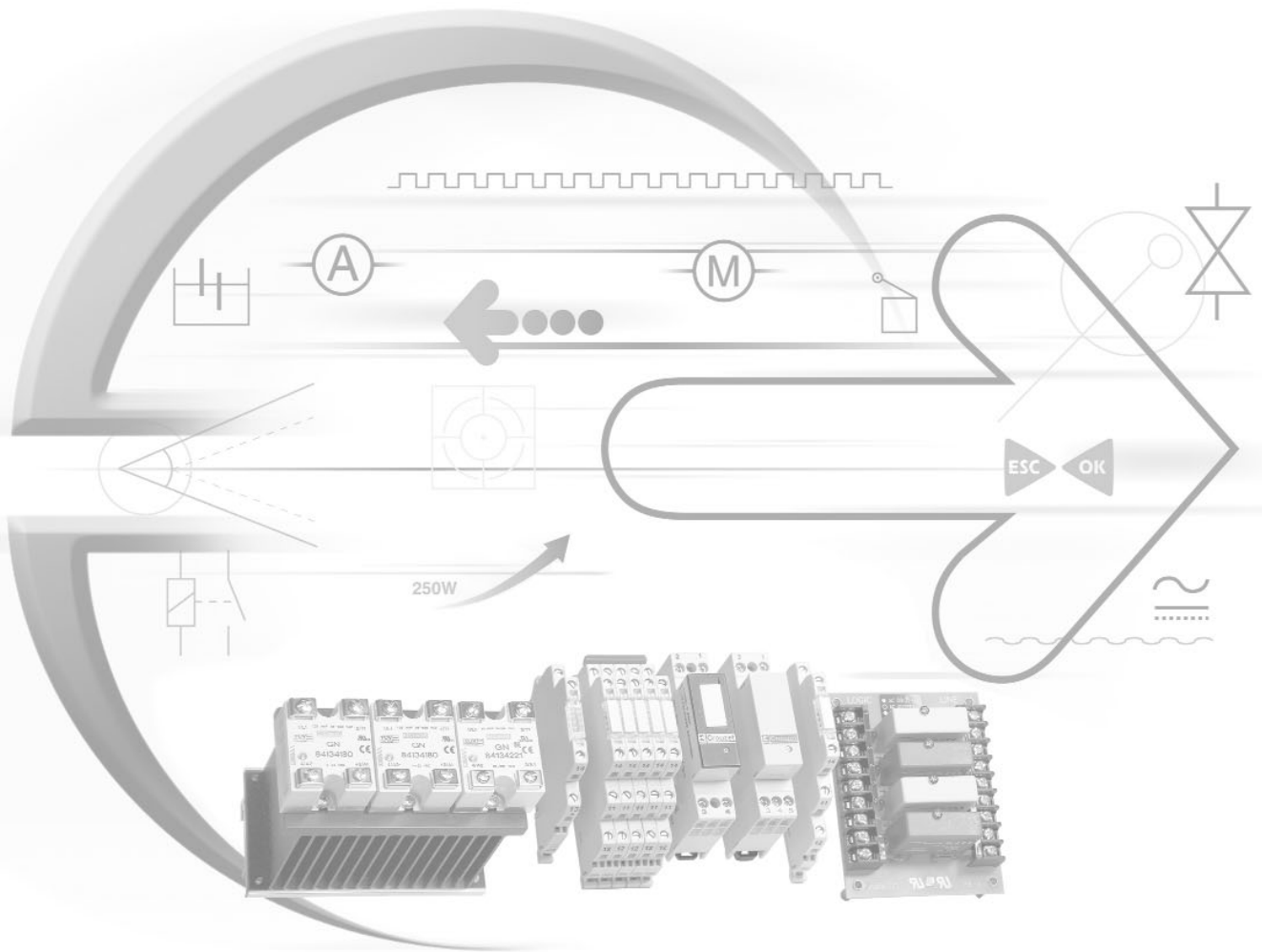

Digital I/O Modules



Products and specifications subject to change without notice.

Order/Technical Support – Tel: (800) 677-5311 / FAX: (800) 677-3865 / www.crouzet-usa.com

DIGITAL I/O MODULES

0.6 INCH INPUT MODULES

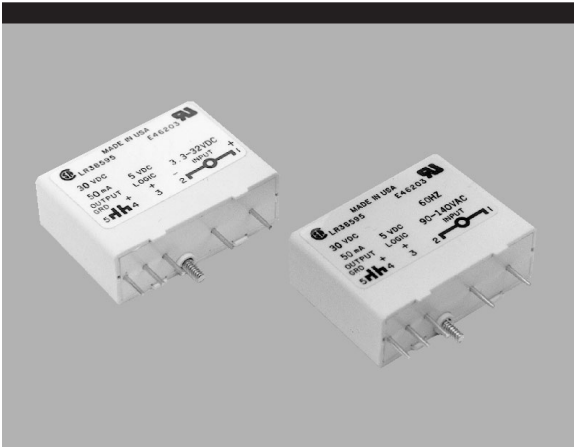

FEATURES:

- CE Compliant
- Plug into Mounting Boards for 0.6" Modules
- AC Inputs for 24 V, 120 V, 240 V
- DC Inputs for 3.3 to 32 V, 10 to 48 V
- UL Recognized (E46203) / CSA Certified (38595)
- 4 kV Optical Isolation
- Open-Collector Output
- Industry Standard Packaging

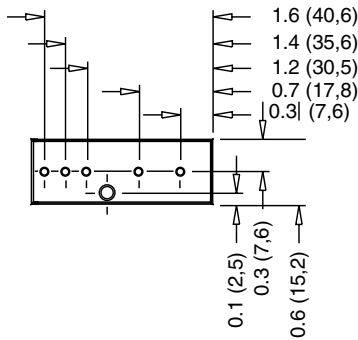
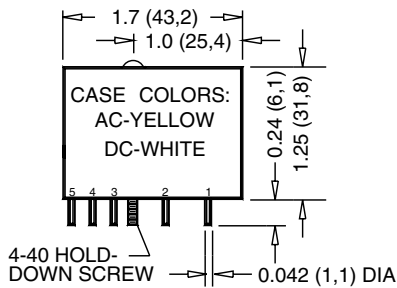

DIMENSIONS: INCHES (MILLIMETERS)
TOLERANCE: ± 0.020 ($\pm 0,50$)

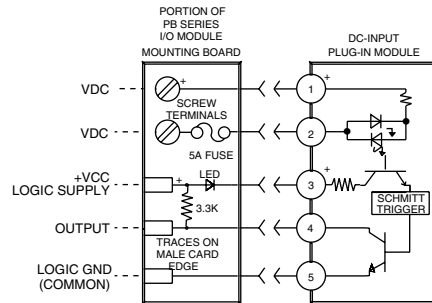
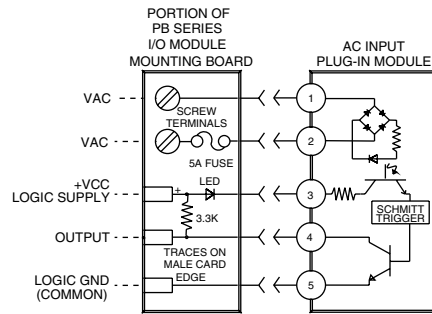

(EQUIVALENT CIRCUIT DIAGRAMS)

Products and specifications subject to change without notice.

Order/Technical Support – Tel: (800) 677-5311 / FAX: (800) 677-3865 / www.crouzet-usa.com

DIGITAL I/O MODULES

0.6 INCH INPUT MODULES

INPUT SPECIFICATIONS: (1)

Model Number	IAC5 IAC24	IAC5A IAC24A	IDC5 IDC24	IDC5F IDC24F	IDC5N IDC24N
Parameter					
Nominal Voltage	120 VAC	240 VAC	5-28 VDC	5-28 VDC	12-48 VDC
Maximum Voltage	140 VAC/VDC	280 VAC/VDC	32 VDC/VAC	32 VDC	48 VDC/VAC
Minimum Voltage	90 VAC/VDC	180 VAC/VDC	3.3 VDC/VAC	4.0 VDC	10 VDC/VAC
Resistance (2) (3)	28 kΩ	75 kΩ	1 kΩ	500 Ω	2.7 kΩ
Maximum Current (4)	6 mArms	5 mArms	34 mA	68 mA	34 mA
Drop-out Current (5)	2.0 mArms	1.5 mArms	1.0 mA	1.0 mA	1.0 mA
Allowable Current/	2.5 mArms	2.0 mArms	1.5 mA	1.5 mA	1.5 mA
Voltage for No Output (6)	50 VAC/VDC	50 VAC/VDC	2.0 VDC	2.0 VDC	4.0 VDC

OUTPUT SPECIFICATIONS: (1)

Model Number	IAC5 IAC5A IDC5 IDC5F IDC5N	IAC24 IAC24A IDC24 IDC24F IDC24N	Units
Parameter			
Nominal Logic Supply Voltage	5.0	24.0	VDC
Maximum Logic Supply Voltage	6.0	30.0	VDC
Minimum Logic Supply Voltage	3.0	20.0	VDC
Maximum Logic Supply Current (7)	16.0	16.0	mA
Maximum Logic Supply Leakage Current (8)	10.0	10.0	μA
Maximum Voltage (9)	30.0	30.0	VDC
Maximum Current (10)	50.0	50.0	mA
Maximum Leakage Current (11)	10.0	10.0	μA
Maximum Voltage Drop (12)	0.2	0.2	VDC

GENERAL SPECIFICATIONS: (1)

Model Number	IAC5, IAC5A, IAC24, IAC24A	IDC5 IDC24	IDC5F IDC24F	IDC5N IDC24N	Units
Parameter					
Operating Temperature Range	-30 to 80	-30 to 80	-30 to 80	-30 to 80	°C
Storage Temperature Range	-40 to 100	-40 to 100	-40 to 100	-40 to 100	°C
Maximum Turn-on Time (13)	20	1.0	0.05	8.0	mSec
Maximum Turn-off Time (13)	20	1.0	0.10	7.0	mSec
Input/Output Isolation Voltage (14)	4000	4000	4000	4000	VAC
Input/Output Capacitance (typical)	8	8	8	8	pF
Line Frequency Range	47 to 63	DC	DC	DC	Hertz
Weight	1.1 oz	1.1 oz	1.1 oz	1.1 oz	

TABLE OF MODEL NUMBER SUFFIXES IDENTIFYING OPTIONAL FEATURES

Suffix	Feature
A	High voltage versions (240 VAC for AC modules).
F	Fast-switching version of DC Modules.
N	Enhanced noise immunity version of DC modules.

Notes:

- (1) Specifications apply to an ambient temperature of -30 to 80°C unless otherwise noted.
- (2) Resistance values for IAC modules are effective impedance values at 25°C.
- (3) Resistance values are +/-10% at 25°C.
- (4) Measured at maximum specified input voltage, 25°C.
- (5) Defined as the maximum current allowed through the module's input to guarantee that the output will switch from "on" to "off." Higher currents may result in the output remaining in the "on" state.
- (6) Defined as the maximum current allowed through the module's input that will not switch the module's output state from "off" to "on."
- (7) With external LED status indicator at maximum specified logic supply voltage and 25°C. 18 mA without external LED status indicator.
- (8) At maximum specified logic voltage and 25°C.
- (9) Maximum allowable applied voltage across open collector output transistor.
- (10) Maximum allowable sinking current through open collector output transistor.
- (11) At maximum output voltage and 25°C.
- (12) At maximum allowable output current and 25°C.
- (13) At nominal logic supply voltage, 25 mA output sinking current, nominal input voltage and 25°C.
- (14) At 25°C for 1 second maximum duration.

Products and specifications subject to change without notice.

Order/Technical Support – Tel: (800) 677-5311 / FAX: (800) 677-3865 / www.crouzet-usa.com

DIGITAL I/O MODULES

0.6 INCH OUTPUT MODULES



FEATURES:

- CE Compliant
- UL Recognized/Horse Power Rated (E46203)/CSA Certified (38595)
- AC Modules have High Current Thyristor with 100 Amp Surge Capability
- Zero or Random Turn-On Available in AC Modules
- Plug into Mounting Boards for 0.6" Modules
- 4 kV Optical Isolation (1500 VAC Optical Isolation for FET DC Output Modules)
- Industry Standard Packaging
- 3.5 Amp AC Modules Provide Extra Switching Capability
- Form "A" Output
- 5.0 Amp AC(OAC5AH) and DC Modules Available

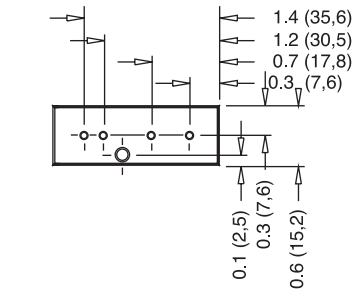
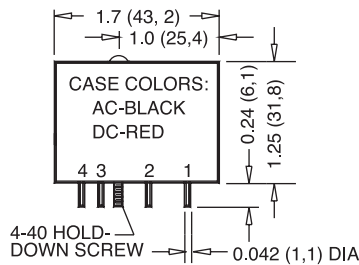

DIMENSIONS: INCHES (MILLIMETERS)
 TOLERANCE: ±0.020 (±0,50)

DERATING CURVE FOR OAC5AH ONLY:

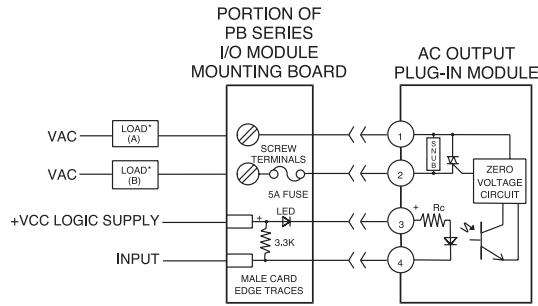
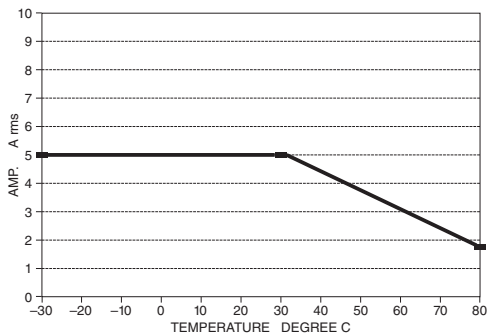

* LOAD MAY BE WIRED IN LOCATION A OR B

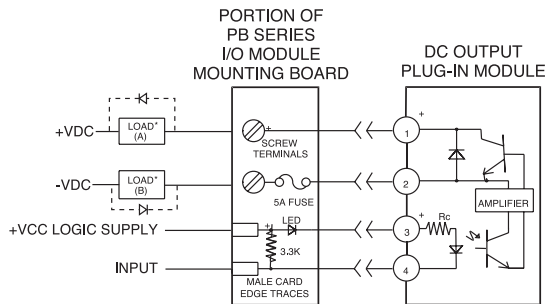

*LOAD MAY BE WIRED IN LOCATION A OR B
 DC INDUCTIVE LOADS MUST BE DIODE SUPPRESSED TO PREVENT DAMAGE TO THE I/O MODULE.

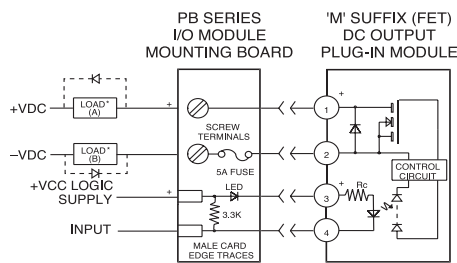

* LOAD MAY BE WIRED IN LOCATION A OR B
 DC INDUCTIVE LOADS MUST BE DIODE SUPPRESSED TO PREVENT DAMAGE TO THE I/O MODULE.

(EQUIVALENT CIRCUIT DIAGRAMS)

Products and specifications subject to change without notice.

Order/Technical Support – Tel: (800) 677-5311 / FAX: (800) 677-3865 / www.crouzet-usa.com

DIGITAL I/O MODULES

0.6 INCH OUTPUT MODULES

INPUT SPECIFICATIONS: (1)

Model Number	OAC5 OAC5A OAC5AH OAC5AR OAC5R	ODC5 ODC5A ODC5F ODC5MA ODC5MC ODC5ML	OAC24 OAC24A ODC24 ODC24A ODC24F	Units
Nominal Voltage	5.0	5.0	24.0	VDC
Minimum Voltage (2)	2.75	2.75	18.0	VDC
Maximum Voltage	8.0	8.0	32.0	VDC
Drop-Out Voltage	1.0	1.0	1.0	VDC
Maximum Current (3)	20.0	18.0	13.0	mA
Resistance (4)	220	250	2000	Ohms

OUTPUT SPECIFICATIONS: (1)

Model Number	OAC5 OAC5R OAC24	OAC5A OAC5AR OAC24A	OAC5AH	ODC5 ODC24	ODC5A ODC24A	ODC5F ODC24F	ODC5MA	ODC5MC	ODC5ML
Nominal Line Voltage	120 VAC	240 VAC	240 VAC	5-48 V	5-150 V	5-48 V	5-150 V	5-90 V	5-48 V
Minimum Line Voltage	12 VAC	24 VAC	24 VAC	3.0 V	3.0 V	3.0 V	1.0 V	1.0 V	1.0 V
Maximum Line Voltage	140 VAC	280 VAC	280 VAC	60 V	250 V	60 V	200 V	100 V	50 V
Max Off-State Voltage (5)	400 Vpeak	600 Vpeak	600 Vpeak	60 V	250 V	60 V	200 V	100 V	50 V
Max Off-State Leakage (6)	.1 mArms	.1 mArms	.1 mArms	10 µA	10 µA	10 µA	10 µA	10 µA	10 µA
Static Off-State dv/dt (7)	200 V / µsec	200 V / µsec	200 V / µsec	N/A	N/A	N/A	N/A	N/A	N/A
Maximum Rated On-State Current (8)	3.5 Arms	3.5 Arms	5.0 A	3.0 A	1.0 A	3.0 A	3.0 A	5.0 A	5.0 A
Minimum On-State Current	50 mArms	50 mArms	50 mArms	10 mA	10 mA	10 mA	1.0 mA	1.0 mA	1.0 mA
Maximum Surge Current (9)	100 Apeak	100 Apeak	100 Apeak	5.0 A	5.0 A	5.0 A	10 A	10 A	10 A
On-State Voltage Drop or Resistance (10)	1.6 V	1.6 V	1.6 V	1.5 V	1.5 V	1.5 V	0.25 Ω	0.10 Ω	0.05 Ω
H.P. Rating (13)	1/8 H.P.	1/3 H.P.	1/2 H.P.	N/A	N/A	N/A	N/A	N/A	N/A

GENERAL SPECIFICATIONS: (1)

Model Number	OAC5 OAC5A OAC5AH OAC24 OAC24A	OAC5R OAC5AR	ODC5 ODC5A ODC24 ODC24A	ODC5F ODC24F	ODC5MA ODC5MC ODC5ML	Units
Operating Temperature Range	-30 to 80	-30 to 80	-30 to 80	-30 to 80	-30 to 80	°C
Storage Temperature Range	-40 to 100	-40 to 100	-40 to 100	-40 to 100	-40 to 100	°C
Maximum Turn-on Time (11)	8.33	0.1	0.1	0.025	1.0	mSec
Maximum Turn-off Time (11)	8.33	8.33	0.75	0.05	0.05	mSec
Input/Output Isolation Voltage (12)	4000	4000	4000	4000	1500	VAC
Input/Output Capacitance (typical)	8	8	8	8	8	pF
Line Frequency Range	47 to 63	47 to 63	DC	DC	DC	Hertz
Weight	1.1 oz	1.1 oz	1.1 oz	1.1 oz	1.1 oz	

TABLE OF MODEL NUMBER SUFFIXES IDENTIFYING OPTIONAL FEATURES

Suffix	Feature
A	High voltage versions (240 VAC for AC modules, 250 VDC for DC modules).
AH	High voltage AC, 5 Amps.
F	Fast-switching version of ODC modules.
MA	FET output version of DC module, 3.0 A, 200 VDC.
MC	FET output version of DC module, 5.0 A, 100 VDC.
ML	FET output version of DC module, 5.0 A, 50 VDC.
R	Random AC voltage turn-on.

Notes:

- (1) Specifications apply to an ambient temperature of -30 to 80°C unless otherwise noted.
- (2) Without external LED status indicator. Add 1.7 volt for external LED if utilized.
- (3) At nominal input voltage, without external LED status indicator.
- (4) +/-10% at 25°C.
- (5) Maximum 1 minute duration for OAC modules when applied as a DC voltage rather than peak AC voltage.
- (6) At maximum line voltage, 25°C for OAC modules, and 80°C for ODC modules.
- (7) Minimum dv/dt per EIA/NARM RS443, method RS397. dv/dt ratings do not apply to ODC modules.
- (8) At 40°C, derate OAC modules by 58 mA/°C to 80°C; derate ODC, ODCxMC and ODCxML modules by 50 mA/°C to 80°C; derate ODCxMA modules by 30 mA/°C to 80°C. CSA rating of OAC modules is 3.0 Arms at 40°C.
- (9) At 25°C. Maximum duration: 1 AC cycle for OAC modules, 1 second for ODC modules.
- (10) At maximum rated on-state current and 25°C.
- (11) At maximum line voltage, maximum rated output current, nominal input voltage, 25°C. Switching speed of OAC modules based upon 60 Hz line frequency.
- (12) At 25°C for 1 second maximum duration.
- (13) 1/3 H.P. at 240 VAC, 1/8 H.P. at 120 VAC.

Products and specifications subject to change without notice.

Order/Technical Support – Tel: (800) 677-5311 / FAX: (800) 677-3865 / www.crouzet-usa.com

DIGITAL I/O MODULES

M SERIES INPUT MODULES

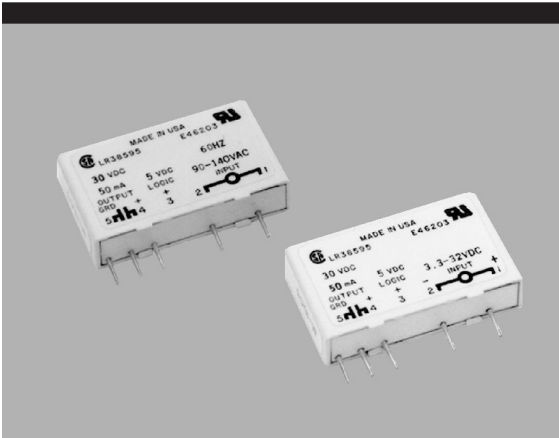

FEATURES:

- CE Compliant
- Plug into Mounting Boards for M Series Modules
- AC Inputs for 24 V, 120 V, 240 V
- DC Inputs for 3.3 to 32 V, 10 to 48 V
- UL Recognized (E46203)/CSA Certified (38595)
- 4 kV Optical Isolation
- Open-Collector Output
- Industry Standard Packaging

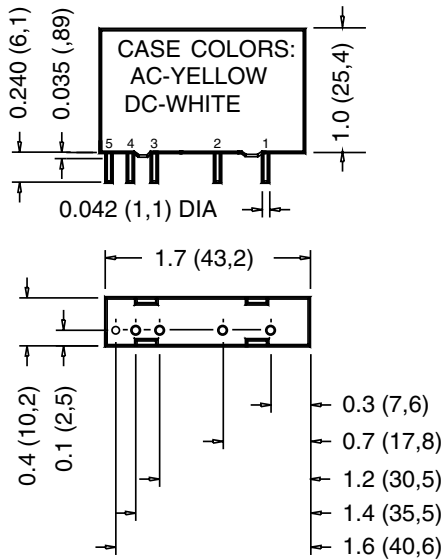

DIMENSIONS: INCHES (MILLIMETERS)
TOLERANCE: ± 0.020 ($\pm 0,50$)

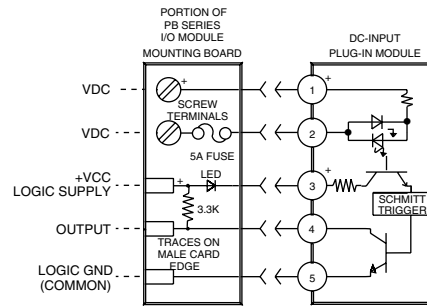
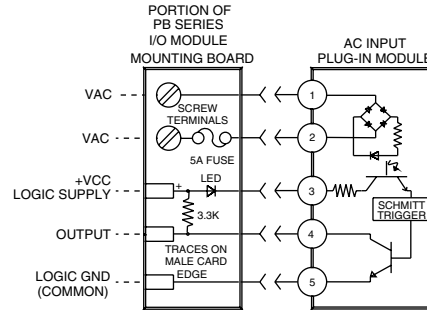

(EQUIVALENT CIRCUIT DIAGRAMS)

Products and specifications subject to change without notice.

Order/Technical Support – Tel: (800) 677-5311 / FAX: (800) 677-3865 / www.crouzet-usa.com

DIGITAL I/O MODULES

M SERIES INPUT MODULES

INPUT SPECIFICATIONS: (1)

Model Number	MIAC5 MIAC24	MIAC5A MIAC24A	MIDC5 MIDC24	MIDC5F	MIDC5N
Parameter					
Nominal Voltage	120 VAC	240 VAC	5-28 VDC	5-28 VDC	12-48 VDC
Maximum Voltage	140 VAC/VDC	280 VAC/VDC	32 VDC/VAC	32 VDC	48 VDC/VAC
Minimum Voltage	90 VAC/VDC	180 VAC/VDC	3.3 VDC/VAC	4.0 VDC	10 VDC/VAC
Resistance (2) (3)	28 kΩ	75 kΩ	1 kΩ	500 Ω	2 kΩ
Maximum Current (4)	5 mArms	5 mArms	34 mA	68 mA	34 mA
Drop-out Current (5)	2.0 mArms	1.5 mArms	1.0 mA	1.0 mA	1.0 mA
Allowable Current/	2.5 mArms	2.0 mArms	1.5 mA	1.5 mA	1.5 mA
Voltage for No Output (6)	50 VAC/VDC	50 VAC/VDC	2.0 VDC	2.0 VDC	4.0 VDC

OUTPUT SPECIFICATIONS: (1)

Model Number	MIAC5 MIAC5A MIDC24 MIDC5 MIDC5F MIDC5N	MIAC24 MIAC24A	Units
Parameter			
Nominal Logic Supply Voltage	5.0	24.0	VDC
Maximum Logic Supply Voltage	6.0	30.0	VDC
Minimum Logic Supply Voltage	3.0	20.0	VDC
Maximum Logic Supply Current (7)	16.0	16.0	mA
Maximum Logic Supply Leakage Current (8)	10.0	10.0	μA
Maximum Voltage (9)	30.0	30.0	VDC
Maximum Current (10)	50.0	50.0	mA
Maximum Leakage (11)	10.0	10.0	μA
Maximum Voltage Drop (12)	0.2	0.2	VDC

GENERAL SPECIFICATIONS: (1)

Model Number	MIAC5, MIAC5A, MIAC24, MIAC24A	MIDC5 MIDC24	MIDC5F	MIDC5N	Units
Parameter					
Operating Temperature Range	-30 to 80	-30 to 80	-30 to 80	-30 to 80	°C
Storage Temperature Range	-40 to 100	-40 to 100	-40 to 100	-40 to 100	°C
Maximum Turn-on Time (13)	20	1.0	0.05	8.0	mSec
Maximum Turn-off Time (13)	20	1.0	0.10	7.0	mSec
Input/Output Isolation Voltage (14)	4000	4000	4000	4000	VAC
Input/Output Capacitance (typical)	8	8	8	8	pF
Line Frequency Range	47 to 63	DC	DC	DC	Hertz
Weight	.65 oz	.65 oz	.65 oz	.65 oz	

TABLE OF MODEL NUMBER SUFFIXES IDENTIFYING OPTIONAL FEATURES

Suffix	Feature
A	High voltage versions (240 VAC for AC modules).
F	Fast-switching version of DC modules.
N	Enhanced noise immunity version of IDC module.

Notes:

- (1) Specifications apply to an ambient temperature of -30 to 80°C unless otherwise noted.
- (2) Resistance values for MIAC modules are effective impedance values at 25°C.
- (3) Resistance values are +/-10% at 25°C.
- (4) Measured at maximum specified input voltage, 25°C.
- (5) Defined as the maximum current allowed through the module's input to guarantee that the output will switch from "on" to "off." Higher currents may result in the output remaining in the "on" state.
- (6) Defined as the maximum current allowed through the module's input that will not switch the module's output state from "off" to "on."
- (7) With external LED status indicator at maximum specified logic supply voltage and 25°C. 18 mA without external LED status indicator.
- (8) At maximum specified logic voltage and 25°C.
- (9) Maximum allowable applied voltage across open collector output transistor.
- (10) Maximum allowable sinking current through open collector output transistor.
- (11) At maximum output voltage and 25°C.
- (12) At maximum allowable output current and 25°C.
- (13) At nominal logic supply voltage, 25 mA output sinking current, nominal input voltage and 25°C.
- (14) At 25°C for 1 second maximum duration.

Products and specifications subject to change without notice.

Order/Technical Support – Tel: (800) 677-5311 / FAX: (800) 677-3865 / www.crouzet-usa.com

DIGITAL I/O MODULES

M SERIES OUTPUT MODULES

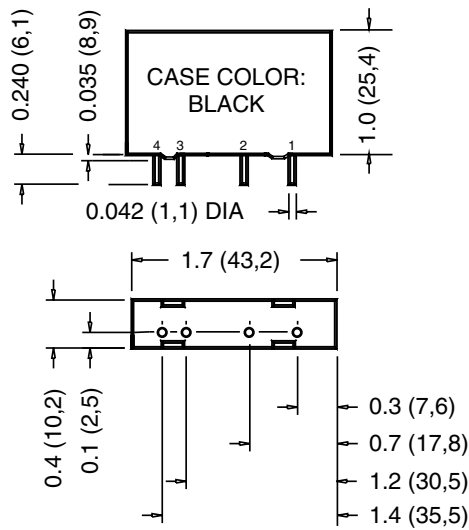
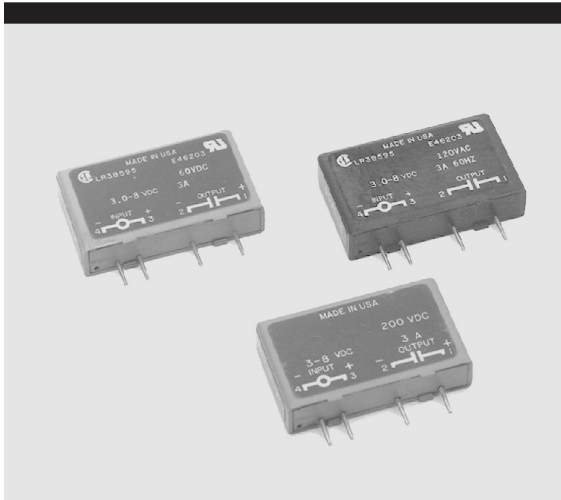

DIMENSIONS: INCHES (MILLIMETERS)
TOLERANCE: ± 0.020 ($\pm 0,50$)

FEATURES:

- CE Compliant
- 5.0 Amp AC (MOAC5AH) and DC Modules Available
- UL Recognized/Horse Power Rated (E79183)/CSA Certified (38595)
- AC Modules have High Current Thyristor with 100 Amp Surge Capability
- Zero or Random Turn-On Available in AC Modules
- Plug into Mounting Boards for M Series Modules
- 4 kV Optical Isolation (1500 VAC Optical Isolation for FET DC Output Modules)
- Industry Standard Packaging

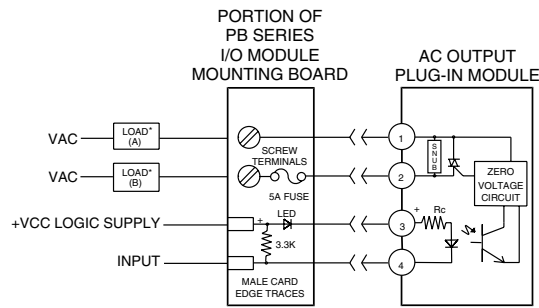

* LOAD MAY BE WIRED IN LOCATION A OR B

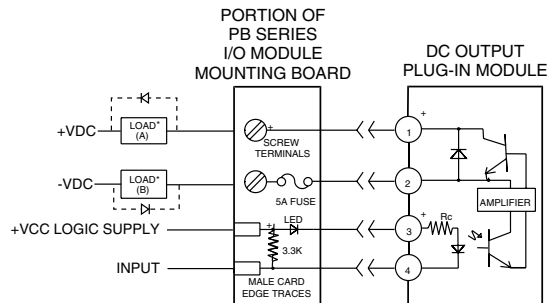

*LOAD MAY BE WIRED IN LOCATION A OR B
DC INDUCTIVE LOADS MUST BE DIODE SUPPRESSED TO PREVENT DAMAGE TO THE I/O MODULE.

DERATING CURVE FOR MOAC5AH:

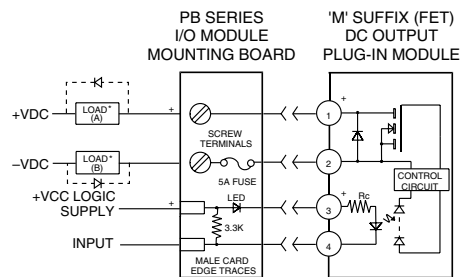
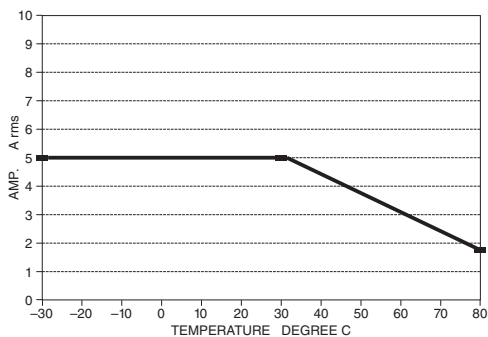

* LOAD MAY BE WIRED IN LOCATION A OR B
DC INDUCTIVE LOADS MUST BE DIODE SUPPRESSED TO PREVENT DAMAGE TO THE I/O MODULE.

(EQUIVALENT CIRCUIT DIAGRAMS)

Products and specifications subject to change without notice.

Order/Technical Support – Tel: (800) 677-5311 / FAX: (800) 677-3865 / www.crouzet-usa.com

DIGITAL I/O MODULES

M SERIES OUTPUT MODULES

INPUT SPECIFICATIONS: (1)

Model Number	MOAC5 MOAC5A MOAC5AR MOAC5R MOAC5AH	MODC5 MODC5A MODC5F MODC5MA MODC5MC MODC5ML	MOAC24 MOAC24A MODC24	Units
Nominal Voltage	5.0	5.0	24.0	VDC
Minimum Voltage (2)	2.75	2.75	18.0	VDC
Maximum Voltage	8.0	8.0	32.0	VDC
Drop-Out Voltage	1.0	1.0	1.0	VDC
Maximum Current (3)	20.0	18.0	13.0	mA
Resistance (4)	220	250	2000	Ohms

OUTPUT SPECIFICATIONS: (1)

Model Number	MOAC5 MOAC5R MOAC24	MOAC5A MOAC5AR MOAC24A	MOAC5AH	MODC5 MODC24	MODC5A	MODC5F	MODC5MA	MODC5MC	MODC5ML
Nominal Line Voltage	120 VAC	240 VAC	240 VAC	5-48 V	5-150 V	5-48 V	5-150 V	5-90 V	5-48 V
Minimum Line Voltage	12 VAC	24 VAC	24 VAC	3.0 V	3.0 V	3.0 V	1.0 V	1.0 V	1.0 V
Maximum Line Voltage	140 VAC	280 VAC	280 VAC	60 V	250 V	60 V	200 V	100 V	50 V
Max Off-State Voltage (5)	400 Vpeak	600 Vpeak	600 Vpeak	60 V	250 V	60 V	200 V	100 V	50 V
Max Off-State Leakage (6)	.1 mArms	.1 mArms	.1 mArms	10 µA	10 µA	10 µA	10 µA	10 µA	10 µA
Static Off-State dv/dt (7)	200 V/µsec	200 V/µsec	200 V/µsec	N/A	N/A	N/A	N/A	N/A	N/A
Maximum Rated On-State Current (8)	3.5 Arms	3.5 Arms	5.0 A	3.0 A	1.0 A	3.0 A	3.0 A	5.0 A	5.0 A
Min On-State Current	50 mArms	50 mArms	50 mArms	10 mA	10 mA	10 mA	1.0 mA	1.0 mA	1.0 mA
Max Surge Current (9)	100 Apeak	100 Apeak	100 Apeak	5.0 A	5.0 A	5.0 A	10 A	10 A	10 A
On-State Voltage Drop or Resistance (10)	1.6 V	1.6 V	1.6 V	1.5 V	1.5 V	1.5 V	0.25 Ω	0.10 Ω	0.05 Ω
H.P. Rating (13)	1/8 H.P.	1/3 H.P.	1/2 H.P.	N/A	N/A	N/A	N/A	N/A	N/A

GENERAL SPECIFICATIONS: (1)

Model Number	MOAC5 MOAC5A MOAC5AH MOAC24 MOAC24A	MOAC5R MOAC5AR	MODC5 MODC5A MODC24	MODC5F	MODC5MA MODC5MC	Units
Operating Temperature Range	-30 to 80	-30 to 80	-30 to 80	-30 to 80	-30 to 80	°C
Storage Temperature Range	-40 to 100	-40 to 100	-40 to 100	-40 to 100	-40 to 100	°C
Maximum Turn-on Time (11)	8.33	0.1	0.1	0.025	1.0	mSec
Maximum Turn-off Time (11)	8.33	8.33	0.75	0.05	0.05	mSec
Input/Output Isolation Voltage (12)	4000	4000	4000	4000	1500	VAC
Input/Output Capacitance (typical)	8	8	8	8	8	pF
Line Frequency Range	47 to 63	47 to 63	DC	DC	DC	Hertz
Weight	.65 oz	.65 oz	.65 oz	.65 oz	.65 oz	

TABLE OF MODEL NUMBER SUFFIXES IDENTIFYING OPTIONAL FEATURES

Suffix	Feature
A	High voltage versions (240 VAC for AC modules, 250 VDC for DC modules).
AH	High voltage AC 5 amp
F	Fast-switching version of DC modules.
MA	FET output version of DC module, 3.0 A, 200 VDC.
MC	FET output version of DC module, 5.0 A, 100 VDC.
ML	FET output version of DC module, 5.0 A, 50 VDC.
R	Random AC voltage turn-on.

Notes:

- (1) Specifications apply to an ambient temperature of -30 to 80°C unless otherwise noted.
- (2) Without external LED status indicator. Add 1.7 volt for external LED if utilized.
- (3) At nominal input voltage, without external LED status indicator.
- (4) +/-10% at 25°C.
- (5) Maximum 1 minute duration for MOAC modules when applied as a DC voltage rather than peak AC voltage.
- (6) At maximum line voltage, 25°C for MOAC modules, and 80°C for MODC modules.
- (7) Minimum dv/dt per EIA/NARM RS443, method RS397. dv/dt ratings do not apply to MODC modules.
- (8) At 40°C, derate MOAC modules by 58 mA/°C to 80°C; derate MODC and MODCxMA modules by 50 mA/°C to 80°C; derate MODCxMC and MODCxML modules by 125 mA/°C to 80°C. CSA rating of MOAC modules is 3.0 Arms at 40°C. For MOAC5AH see derating curve.
- (9) At 25°C. Maximum duration: 1 AC cycle for MOAC modules, 1 second for MODC modules.
- (10) At maximum rated on-state current and 25°C.
- (11) At maximum line voltage, maximum rated output current, nominal input voltage, 25°C. Switching speed of MOAC modules based upon 60 Hz line frequency.
- (12) At 25°C for 1 second maximum duration.
- (13) 1/3 H.P. at 240 VAC, 1/8 H.P. at 120 VAC.

Products and specifications subject to change without notice.

Order/Technical Support – Tel: (800) 677-5311 / FAX: (800) 677-3865 / www.crouzet-usa.com

DIGITAL I/O MODULES

QUAD-PACK INPUT MODULES

INPUT SPECIFICATIONS: (1)

Model Number	IAC5Q	IAC5AQ	IAC5EQ	IDC5Q	IDC5BQ
Nominal Voltage	120 VAC	240 VAC	24 VAC	12-48 VDC	5-28 VDC
Maximum Voltage	140 VAC/VDC	280 VAC/VDC	36 VAC/VDC	60 VDC/VAC	32 VDC
Minimum Voltage	90 VAC/VDC	180 VAC/VDC	18 VAC/VDC	10 VDC/VAC	4.0 VDC
Resistance (2) (3)	28K	75 kΩ	3.3 kΩ	2 kΩ	500 Ω
Maximum Current (4)	6 mArms	5 mArms	10 mArms	34 mA	68 mA
Drop-out Current (5)	2.0 mArms	1.5 mArms	1.0 mArms	1.0 mA	1.0 mA
Allowable Current/ Voltage for No Output (6)	2.5 mArms 50 VAC/VDC	2.0 mArms 50 VAC/VDC	1.5 mArms 10 VAC/VDC	1.5 mA 4.0 VDC	1.5 mA 2.0 VDC

OUTPUT SPECIFICATIONS: (1)

Model Number	IAC5Q IAC5AQ IAC5EQ IDC5Q IDC5BQ	Units
Nominal Logic Supply Voltage	5.0	VDC
Maximum Logic Supply Voltage	6.0	VDC
Minimum Logic Supply Voltage	3.0	VDC
Maximum Logic Supply Current (7)	16.0	mA
Maximum Logic Supply Leakage (8)	10.0	μA
Maximum Voltage (9)	30.0	VDC
Maximum Current (10)	50.0	mA
Maximum Leakage (11)	10.0	μA
Maximum Voltage Drop (12)	0.2	VDC

GENERAL SPECIFICATIONS: (1)

Model Number	IAC5Q, IAC5AQ	IAC5EQ	IDC5Q	IDC5BQ	Units
Operating Temperature Range	-30 to 80	-30 to 80	-30 to 80	-30 to 80	°C
Storage Temperature Range	-40 to 100	-40 to 100	-40 to 100	-40 to 100	°C
Maximum Turn-on Time (13)	20	60	5.0	0.05	mSec
Maximum Turn-off Time (13)	20	30	5.0	0.10	mSec
Input/Output Isolation Voltage (14)	4000	4000	4000	4000	VAC
Input/Output Capacitance (typical)	8	8	8	8	pF
Line Frequency Range	47 to 63	47 to 63	DC	DC	Hertz

TABLE OF MODEL NUMBER SUFFIXES IDENTIFYING OPTIONAL FEATURES

Suffix	Feature
A	High voltage versions (240 VAC for AC modules).
B	Fast switching version of DC modules.
E	Low voltage 24 VAC input for AC modules.
Q	Four-channel quad-pack module.

Notes:

- (1) Specifications apply to an ambient temperature of -30 to 80°C unless otherwise noted.
- (2) Resistance values for IAC Quad Modules are effective impedance values at 25°C.
- (3) Resistance values are +/-10% at 25°C.
- (4) Measured at maximum specified input voltage, 25°C.
- (5) Defined as the maximum current allowed through the module's input to guarantee that the output will switch from "on" to "off." Higher currents may result in the output remaining in the "on" state.
- (6) Defined as the maximum current allowed through the module's input that will not switch the module's output state from "off" to "on."
- (7) With external LED status indicator at maximum specified logic supply voltage and 25°C. 18 mA without external LED status indicator.
- (8) At maximum specified logic voltage and 25°C.
- (9) Maximum allowable applied voltage across open collector output transistor.
- (10) Maximum allowable sinking current through open collector output transistor.
- (11) At maximum output voltage and 25°C.
- (12) At maximum allowable output current and 25°C.
- (13) At nominal logic supply voltage, 25 mA output sinking current, nominal input voltage and 25°C.
- (14) At 25°C for 1 second maximum duration.

Products and specifications subject to change without notice.

Order/Technical Support – Tel: (800) 677-5311 / FAX: (800) 677-3865 / www.crouzet-usa.com

DIGITAL I/O MODULES

QUAD-PACK OUTPUT MODULES



FEATURES:

- CE Compliant
- UL Recognized (E46203)/CSA Certified (38595)
- AC Modules have High Current Thyristor with 100 Amp Surge Capability
- Zero or Random Turn-On Available in AC Modules
- Plug into Mounting Boards for 0.6" Modules
- 4 kV Optical Isolation
- Industry Standard Packaging
- 3.5 Amp AC Modules Provide Extra Switching Capability
- 4 Outputs per Quad-Pack Module

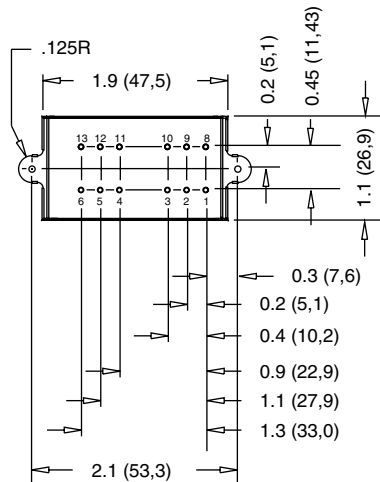
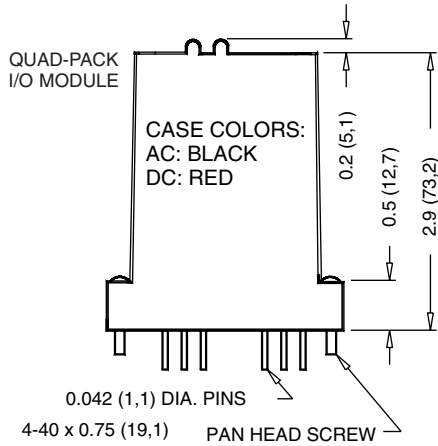

DIMENSIONS: INCHES (MILLIMETERS)
TOLERANCE: ±0.020 (±0,50)

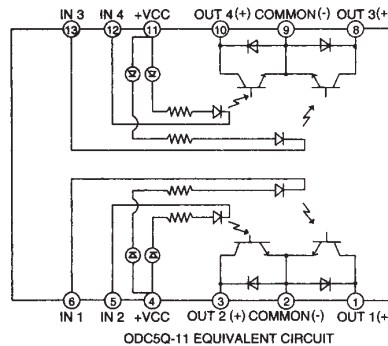
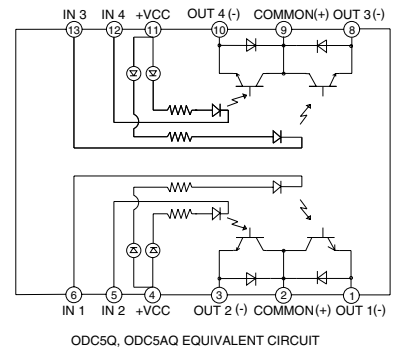
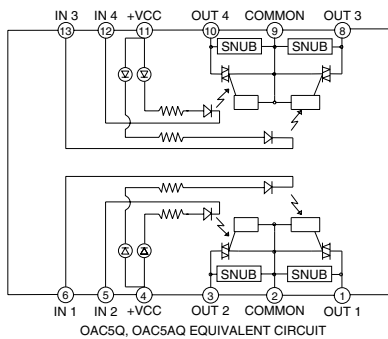

Products and specifications subject to change without notice.

Order/Technical Support – Tel: (800) 677-5311 / FAX: (800) 677-3865 / www.crouzet-usa.com

DIGITAL I/O MODULES

QUAD-PACK OUTPUT MODULES

INPUT SPECIFICATIONS: (1)

Model Number	OAC5Q OAC5AQ OAC5ARQ OAC5RQ	ODC5Q ODC5Q.11	Units
Nominal Voltage	5.0	5.0	VDC
Minimum Voltage	4.0	4.0	VDC
Maximum Voltage	8.0	8.0	VDC
Drop-Out Voltage	1.0	1.0	VDC
Maximum Current (2)	20.0	18.0	mA
Resistance (3)	220	250	Ohms

OUTPUT SPECIFICATIONS: (1)

Model Number	OAC5Q OAC5RQ	OAC5AQ OAC5ARQ	ODC5Q ODC5Q.11
Nominal Line Voltage	120 VAC	240 VAC	5-48 V
Minimum Line Voltage	12 VAC	24 VAC	3.0 V
Maximum Line Voltage	140 VAC	280 VAC	60 V
Max Off-State Voltage (4)	400 Vpeak	600 Vpeak	60 V
Max Off-State Leakage (5)	.1 mArms	.1 mArms	10 μ A
Static Off-State dv/dt (6)	200 V/ μ sec	200 V/ μ sec	N/A
Maximum Rated On-State Current (7)	3.5 Arms	3.5 Arms	3.0 A
Min On-State Current	50 mArms	50 mArms	10 mA
Max Surge Current (8)	100 Apeak	100 Apeak	5.0 A
On-State Voltage Drop or Resistance (9)	1.6 V	1.6 V	1.5 V

GENERAL SPECIFICATIONS: (1)

Model Number	OAC5Q OAC5AQ	OAC5RQ OAC5ARQ	ODC5Q ODC5Q.11	Units
Operating Temperature Range	-30 to 80	-30 to 80	-30 to 80	$^{\circ}$ C
Storage Temperature Range	-40 to 100	-40 to 100	-40 to 100	$^{\circ}$ C
Maximum Turn-on Time (10)	8.33	0.1	0.1	mSec
Maximum Turn-off Time (10)	8.33	8.33	0.75	mSec
Input/Output Isolation Voltage (11)	4000	4000	4000	VAC
Input/Output Capacitance (typical)	8	8	8	pF
Line Frequency Range	47 to 63	47 to 63	DC	Hertz

TABLE OF MODEL NUMBER SUFFIXES IDENTIFYING OPTIONAL FEATURES

Suffix	Feature
A	High voltage versions (240 VAC for AC modules)
Q	Four-channel Quad-pack module.
R	Random AC voltage turn-on.
.11	Common emitter output version of ODC5Q module.

Notes:

- (1) Specifications apply to each Quad-Pack channel at an ambient temperature of -30 to 80°C unless otherwise noted.
- (2) At nominal input voltage, without external LED status indicator.
- (3) +/-10% at 25°C.
- (4) Maximum 1 minute duration for OACQ modules when applied as a DC voltage rather than peak AC voltage.
- (5) At maximum line voltage, 25°C for OACQ modules, and 80°C for ODCQ modules.
- (6) Minimum dv/dt per EIA/NARM RS443, method RS397. dv/dt ratings do not apply to ODCQ modules.
- (7) At 40°C, derate OACQ modules by 58 mA/ $^{\circ}$ C to 80°C; derate ODCQ modules by 50 mA/ $^{\circ}$ C to 80°C. CSA rating of OACQ modules is 3.0 Arms at 40°C.
- (8) At 25°C. Maximum duration: 1 AC cycle for OACQ modules, 1 second for ODCQ modules.
- (9) At maximum rated on-state current and 25°C.
- (10) At maximum line voltage, maximum rated output current, nominal input voltage, 25°C. Switching speed of OACQ modules based upon 60 Hz line frequency.
- (11) At 25°C for 1 second maximum duration.

Products and specifications subject to change without notice.

Order/Technical Support – Tel: (800) 677-5311 / FAX: (800) 677-3865 / www.crouzet-usa.com

DIGITAL I/O MODULES

SM SERIES INPUT MODULES



FEATURES:

- CE Compliant
- Plug into Mounting Boards for SM or 0.6" Modules
- AC Inputs for 24 V, 120 V, 240 V
- DC Inputs for 3.3 to 32 V, 10 to 48 V
- UL Recognized (E46203)/CSA Certified (38595)
- 4 kV Optical Isolation
- Open-Collector Output
- Industry Standard Packaging

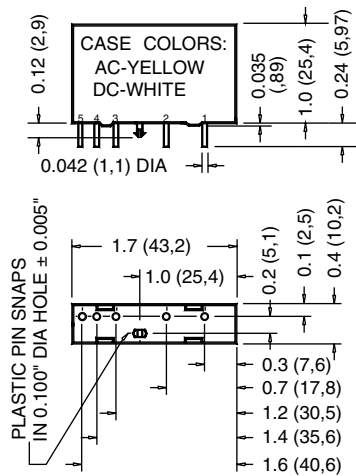

DIMENSIONS: INCHES (MILLIMETERS)
TOLERANCE: ±0.020 (±0,50)

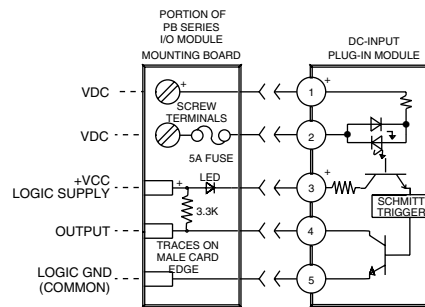
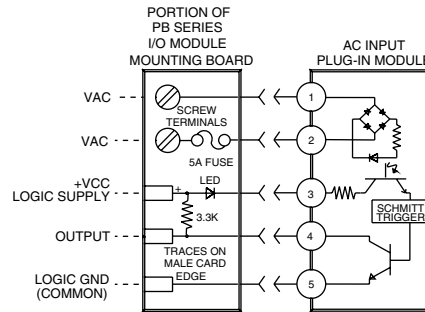

(EQUIVALENT CIRCUIT DIAGRAMS)

Products and specifications subject to change without notice.

Order/Technical Support – Tel: (800) 677-5311 / FAX: (800) 677-3865 / www.crouzet-usa.com

DIGITAL I/O MODULES

SM SERIES INPUT MODULES

INPUT SPECIFICATIONS: (1)

Model Number	SMIAC5 SMIAC24	SMIAC5A SMIAC24A	SMIDC5 SMIDC24	SMIDC5F	SMIDC5N
Parameter					
Nominal Voltage	120 VAC	240 VAC	5-28 VDC	5-28 VDC	12-48 VDC
Maximum Voltage	140 VAC/VDC	280 VAC/VDC	32 VDC/VAC	32 VDC	48 VDC/VAC
Minimum Voltage	90 VAC/VDC	180 VAC/VDC	3.3 VDC/VAC	4.0 VDC	10 VDC/VAC
Input Resistance (2) (3)	28 kΩ	75 kΩ	1 kΩ	500 Ω	2 kΩ
Maximum Current (4)	5 mArms	5 mArms	34 mA	68 mA	34 mA
Drop-out Current (5)	2.0 mArms	1.5 mArms	1.0 mA	1.0 mA	1.0 mA
Allowable Current/	2.5 mArms	2.0 mArms	1.5 mA	1.5 mA	1.5 mA
Voltage for No Output (6)	50 VAC/VDC	50 VAC/VDC	2.0 VDC	2.0 VDC	4.0 VDC

OUTPUT SPECIFICATIONS: (1)

Model Number	SMIAC5 SMIAC5A SMIDC5 SMIDC5F SMIDC5N	SMIAC24 SMIAC24A SMIDC24	Units
Parameter			
Nominal Logic Supply Voltage	5.0	24.0	VDC
Maximum Logic Supply Voltage	6.0	30.0	VDC
Minimum Logic Supply Voltage	3.0	20.0	VDC
Maximum Logic Supply Current (7)	16.0	16.0	mA
Maximum Logic Supply Leakage Current (8)	10.0	10.0	μA
Maximum Voltage (9)	30.0	30.0	VDC
Maximum Current (10)	50.0	50.0	mA
Maximum Leakage Current (11)	10.0	10.0	μA
Maximum Voltage Drop (12)	0.2	0.2	VDC

GENERAL SPECIFICATIONS: (1)

Model Number	SMIAC5, SMIAC5A, SMIAC24, SMIAC24A	SMIDC5 SMIDC24	SMIDC5F	SMIDC5N	Units
Parameter					
Operating Temperature Range	-30 to 80	-30 to 80	-30 to 80	-30 to 80	°C
Storage Temperature Range	-40 to 100	-40 to 100	-40 to 100	-40 to 100	°C
Maximum Turn-on Time (13)	20	1.0	0.05	8.0	mSec
Maximum Turn-off Time (13)	20	1.0	0.10	7.0	mSec
Input/Output Isolation Voltage (14)	4000	4000	4000	4000	VAC
Input/Output Capacitance (typical)	8	8	8	8	pF
Line Frequency Range	47 to 63	DC	DC	DC	Hertz
Weight	.6 oz	.6 oz	.6 oz	.6 oz	

TABLE OF MODEL NUMBER SUFFIXES IDENTIFYING OPTIONAL FEATURES

Suffix	Feature
A	High voltage versions (240 VAC for AC modules).
F	Fast-switching version of DC modules.
N	Enhanced noise immunity version of DC modules.

Notes:

- (1) Specifications apply to an ambient temperature of -30 to 80°C unless otherwise noted.
- (2) Resistance values for SMIAC modules are effective impedance values at 25°C.
- (3) Resistance values are +/-10% at 25°C.
- (4) Measured at maximum specified input voltage, 25°C.
- (5) Defined as the maximum current allowed through the module's input to guarantee that the output will switch from "on" to "off." Higher currents may result in the output remaining in the "on" state.
- (6) Defined as the maximum current allowed through the module's input that will not switch the module's output state from "off" to "on."
- (7) With external LED status indicator at maximum specified logic supply voltage and 25°C. 18 mA without external LED status indicator.
- (8) At maximum specified logic voltage and 25°C.
- (9) Maximum allowable applied voltage across open collector output transistor.
- (10) Maximum allowable sinking current through open collector output transistor.
- (11) At maximum output voltage and 25°C.
- (12) At maximum allowable output current and 25°C.
- (13) At nominal logic supply voltage, 25 mA output sinking current, nominal input voltage and 25°C.
- (14) At 25°C for 1 second maximum duration.

Products and specifications subject to change without notice.

Order/Technical Support – Tel: (800) 677-5311 / FAX: (800) 677-3865 / www.crouzet-usa.com

DIGITAL I/O MODULES

SM SERIES OUTPUT MODULES

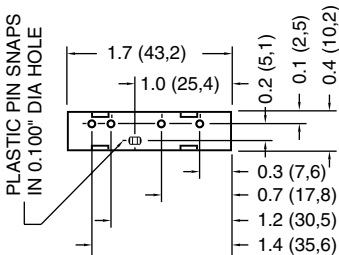
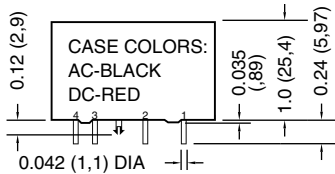

DIMENSIONS: INCHES (MILLIMETERS)
TOLERANCE: ±0.020 (±0,50)

DERATING CURVE FOR SMOAC5AH ONLY:

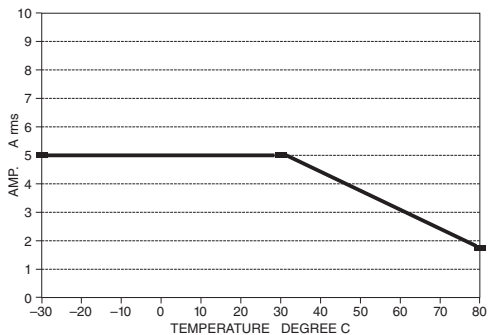

FEATURES:

- CE Compliant
- UL Recognized/Horse Power Rated (E46203)/CSA Certified (38595)
- AC Modules have High Current Thyristor with 100 Amp Surge Capability
- Zero or Random Turn-On Available in AC Modules
- Plug into Mounting Boards for SM or 0.6" Modules
- 4 kV Optical Isolation (1500 VAC Optical Isolation for FET DC Output Modules)
- Industry Standard Packaging
- 3.5 Amp AC Modules Provide Extra Switching Capability
- 5.0 Amp AC (SMOAC5AH) AND DC Modules Available

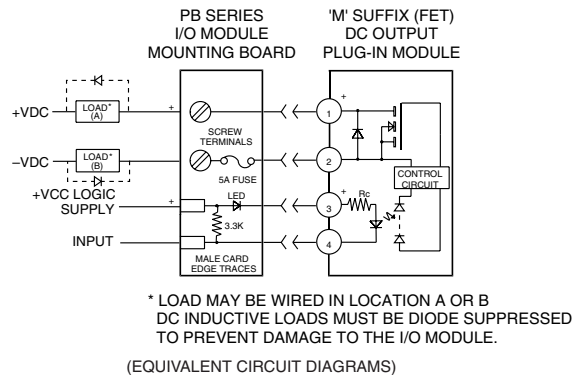
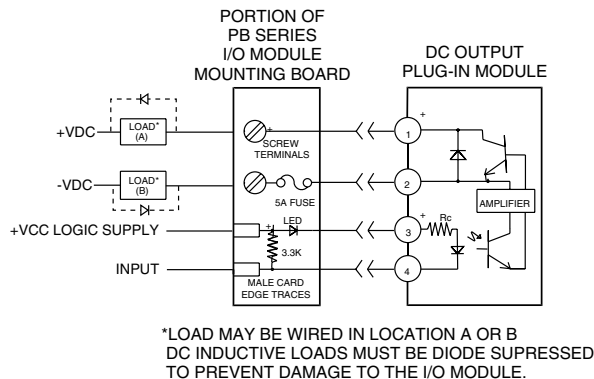
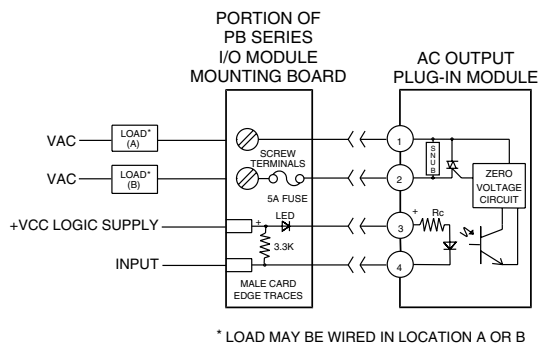

Products and specifications subject to change without notice.

Order/Technical Support – Tel: (800) 677-5311 / FAX: (800) 677-3865 / www.crouzet-usa.com

DIGITAL I/O MODULES

SM SERIES OUTPUT MODULES

INPUT SPECIFICATIONS: (1)

Model Number	SMOAC5 SMOAC5A SMOAC5AH SMOAC5AR SMOAC5R	SMODC5 SMODC5A SMODC5F SMODC5MA SMODC5MC SMODC5ML	SMOAC24 SMOAC24A SMODC24	Units
Nominal Voltage	5.0	5.0	24.0	VDC
Minimum Voltage (2)	2.75	2.75	18.0	VDC
Maximum Voltage	8.0	8.0	32.0	VDC
Drop-Out Voltage	1.0	1.0	1.0	VDC
Maximum Current (3)	20.0	18.0	13.0	mA
Resistance (4)	220	250	2000	Ohms

OUTPUT SPECIFICATIONS: (1)

Model Number	SMOAC5 SMOAC5R SMOAC24	SMOAC5A SMOAC5AR SMOAC24A	SMOAC5AH	SMODC5 SMODC24	SMODC5A	SMODC5F	SMODC5MA	SMODC5MC	SMODC5ML
Nominal Line Voltage	120 VAC	240 VAC	240 VAC	5-48 V	5-150 V	5-48 V	5-150 V	5-90 V	5-48 V
Minimum Line Voltage	12 VAC	24 VAC	24 VAC	3.0 V	3.0 V	3.0 V	1.0 V	1.0 V	1.0 V
Maximum Line Voltage	140 VAC	280 VAC	280 VAC	60 V	250 V	60 V	200 V	100 V	50 V
Max Off-State Voltage (5)	400 Vpeak	600 Vpeak	600 Vpeak	60 V	250 V	60 V	200 V	100 V	50 V
Max Off-State Leakage (6)	.1 mArms	.1 mArms	.1 mArms	10 µA	10 µA	1.0 mA	10 µA	10 µA	10 µA
Static Off-State dv/dt (7)	200 V/µsec	200 V/µsec	200 V/µsec	N/A	N/A	N/A	N/A	N/A	N/A
Maximum Rated On-State Current (8)	3.5 Arms	3.5 Arms	5.0 A	3.0 A	1.0 A	3.0A	3.0 A	5.0 A	5.0 A
Min On-State Current	50 mArms	50 mArms	50 mArms	10 mA	10 mA	10 mA	1.0 mA	1.0 mA	1.0 mA
Max Surge Current (9)	100 Apeak	100 Apeak	100 Apeak	5.0 A	5.0 A	5.0 A	10 A	10 A	10 A
On-State Voltage Drop or Resistance (10)	1.6 V	1.6 V	1.6 V	1.5 V	1.5 V	1.5 V	0.25 Ω	0.10 Ω	0.05 Ω
H.P. Rating (13)	1/4 H.P.	1/4 H.P.	1/2 H.P.	N/A	N/A	N/A	N/A	N/A	N/A

GENERAL SPECIFICATIONS: (1)

Model Number	SMOAC5 SMOAC5A SMOAC5AH SMOAC24 SMOAC24A	SMOAC5R SMOAC5AR	SMODC5 SMODC5A SMODC24	SMODC5F	SMODC5MA SMODC5MC SMODC5ML	Units
Operating Temperature Range	-30 to 80	-30 to 80	-30 to 80	-30 to 80	-30 to 80	°C
Storage Temperature Range	-40 to 100	-40 to 100	-40 to 100	-40 to 100	-40 to 100	°C
Maximum Turn-on Time (11)	8.33	0.1	0.1	0.025	1.0	mSec
Maximum Turn-off Time (11)	8.33	8.33	0.75	0.05	0.05	mSec
Input/Output Isolation Voltage (12)	4000	4000	4000	4000	1500	VAC
Input/Output Capacitance (typical)	8	8	8	8	8	pF
Line Frequency Range	47 to 63	47 to 63	DC	DC	DC	Hertz
Weight	.65 oz	.65 oz	.65 oz	.65 oz	.65 oz	

TABLE OF MODEL NUMBER SUFFIXES IDENTIFYING OPTIONAL FEATURES

Suffix	Feature
A	High voltage versions (240 VAC for AC modules, 250 VDC for DC modules).
AH	High Voltage AC, 5 A
F	Fast-switching version of DC modules.
MA	FET output version of DC module, 3.0 A, 200 VDC.
MC	FET output version of DC module, 5.0 A, 100 VDC.
ML	FET output version of DC module, 5.0 A, 50 VDC.
R	Random AC voltage turn-on.

Notes:

- (1) Specifications apply to an ambient temperature of -30 to 80°C unless otherwise noted.
- (2) Without external LED status indicator. Add 1.7 volt for external LED if utilized.
- (3) At nominal input voltage, without external LED status indicator.
- (4) +/-10% at 25°C.
- (5) Maximum 1 minute duration for SMOAC modules when applied as a DC voltage rather than peak AC voltage.
- (6) At maximum line voltage, 25°C for SMOAC modules, and 80°C for SMODC modules.
- (7) Minimum dv/dt per EIA/NARM RS443, method RS397. dv/dt ratings do not apply to SMODC modules.
- (8) At 40°C, derate SMOAC modules by 58 mA/°C to 80°C; derate SMODC and SMODCxMA modules by 50 mA/°C to 80°C; derate SMODCxMC and SMODCxML modules by 125 mA/°C to 80°C. CSA rating of SMOAC modules is 3.0 Arms at 40°C. For SMOAC5AH see derating curve.
- (9) At 25°C. Maximum duration: 1 AC cycle for SMOAC modules, 1 second for SMODC modules.
- (10) At maximum rated on-state current and 25°C.
- (11) At maximum line voltage, maximum rated output current, nominal input voltage, 25°C. Switching speed of SMOAC modules based upon 60 Hz line frequency.
- (12) At 25°C for 1 second maximum duration.
- (13) 1/4 H.P. at 240 VAC, 1/8 H.P. at 120 VAC.

Products and specifications subject to change without notice.

Order/Technical Support – Tel: (800) 677-5311 / FAX: (800) 677-3865 / www.crouzet-usa.com

DIGITAL I/O MODULES

0.6 INCH, M, SM OUTPUT MODULES



FEATURES:

- CE Compliant
- Available in three physical configurations
- UL Recognized (E46203) / CSA Certified (38595)
- 4 kV Optical Isolation

0.6" SERIES

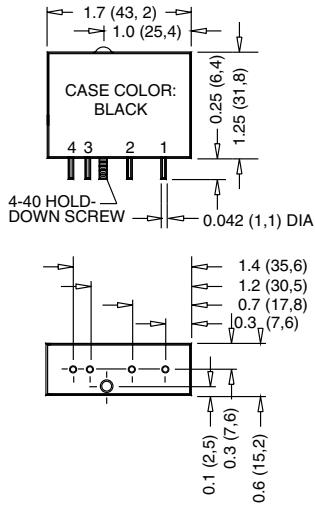

M SERIES

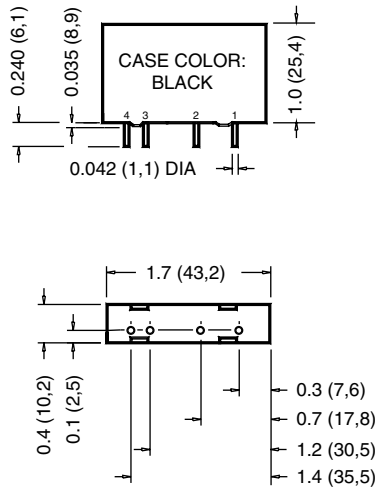

SM SERIES

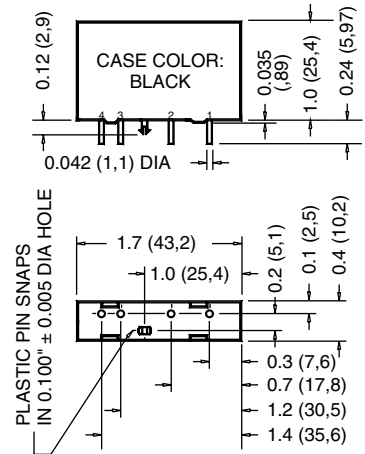

DIMENSIONS: INCHES (MILLIMETERS)
TOLERANCE: ± 0.020 ($\pm 0,50$)

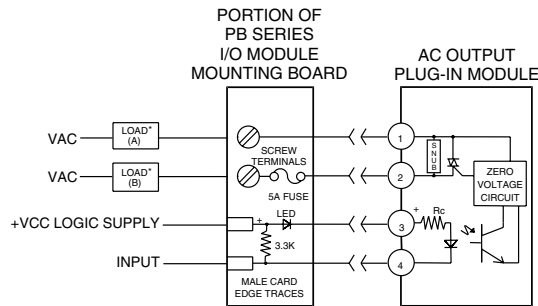

* LOAD MAY BE WIRED IN LOCATION A OR B

Products and specifications subject to change without notice.

Order/Technical Support – Tel: (800) 677-5311 / FAX: (800) 677-3865 / www.crouzet-usa.com

DIGITAL I/O MODULES

0.6 INCH, M, SM OUTPUT MODULES

INPUT SPECIFICATIONS: (1)

Model Number	OACU OACUA OACUAH MOACU MOACUA MOACUAH	SMOACU SMOACUA SMOACUAH	Units
Nominal Voltage		15	VDC
Minimum Voltage (2)		3	VDC
Maximum Voltage		15	VDC
Drop-Out Voltage		1	VDC
Maximum Current (3)		44	mA
Resistance (4)		360	Ohms

OUTPUT SPECIFICATIONS: (1)

Model Number	OACU MOACU SMOACU	OACUA MOACUA SMOACUA	OACUAH MOACUAH SMOACUAH
Nominal Line Voltage	120 VAC	240 VAC	240 VAC
Minimum Line Voltage	12 VAC	24 VAC	24 VAC
Maximum Line Voltage	140 VAC	280 VAC	280 VAC
Max Off-State Voltage (5)	400 Vpeak	600 Vpeak	600 Vpeak
Max Off-State Leakage (6)	1.75 mA	1.75 mA	1.75 mA
Static Off-State dv/dt (7)	200 V / μ sec	200 V / μ sec	200 V / μ sec
Maximum Rated On-State Current (8)	3.5 Arms	3.5 Arms	5.0 Arms
Minimum On-State Current	50 mArms	50 mArms	50 mArms
Maximum Surge Current (9)	100 Apeak	100 Apeak	250 Apeak
On-State Voltage Drop or Resistance (10)	1.6 V	1.6 V	1.6 V
H.P. Rating (13)	1/4 H.P.	1/4 H.P.	

GENERAL SPECIFICATIONS: (1)

Model Number	OACU OACUA OACUAH	MOACU MOACUA MOACUAH	SMOACU SMOACUA SMOACUAH	Units
Operating Temperature Range		-30 to 80		°C
Storage Temperature Range		-40 to 100		°C
Maximum Turn-on Time (11)		8.33		mSec
Maximum Turn-off Time (11)		8.33		mSec
Input/Output Isolation Voltage (12)		4000		VAC
Input/Output Capacitance (typical)		8		pF
Line Frequency Range		47 to 63		Hertz

TABLE OF MODEL NUMBER SUFFIXES IDENTIFYING OPTIONAL FEATURES

Suffix Feature

Notes:

- (1) Specifications apply to an ambient temperature of -30 to 80°C unless otherwise noted.
- (2) Without external LED status indicator. Add 1.7 volt for external LED if utilized.
- (3) At nominal input voltage, without external LED status indicator.
- (4) +/-10% at 25°C.
- (5) Maximum 1 minute duration for OAC modules when applied as a DC voltage rather than peak AC voltage.
- (6) At maximum line voltage, 25°C for OAC modules.
- (7) Minimum dv/dt per EIA/NARIM RS443, method RS397.
- (8) At 40°C, derate OAC modules by 58 mA/°C to 80°C. CSA rating of OAC modules is 3.0 Arms at 40°C.
- (9) At 25°C. Maximum duration: 1 AC cycle for OAC modules.
- (10) At maximum rated on-state current and 25°C.
- (11) At maximum line voltage, maximum rated output current, nominal input voltage, 25°C. Switching speed of OAC modules based upon 60 Hz line frequency.
- (12) At 25°C for 1 second maximum duration.
- (13) 1/4 H.P. at 240 VAC, 1/8 H.P. at 120 VAC.

Products and specifications subject to change without notice.

Order/Technical Support – Tel: (800) 677-5311 / FAX: (800) 677-3865 / www.crouzet-usa.com

DIGITAL I/O MODULES

0.6 INCH, M, SM AND QUAD-PACK REED RELAY OUTPUT MODULES



FEATURES:

- 575 VAC/VDC Universal Output Rating Eliminates Need for Separate AC and DC Modules
- 1 μ A Off-State Leakage Current Permits Reliable Switching of Sensitive Devices
- No Minimum Output Voltage or Current Limitation Allows Unrestricted Application
- 10 Million Operations Provide Long Life Switching up to 25 Volt/Amp Loads
- 2,500 VAC Isolation
- 5, 24 Volt Versions for a Wide Variety of Logic Circuit Applications
- Available in Four Physical Configurations

0.6" SERIES

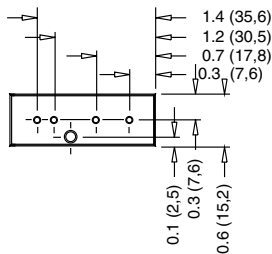
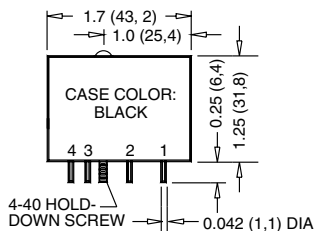

M SERIES

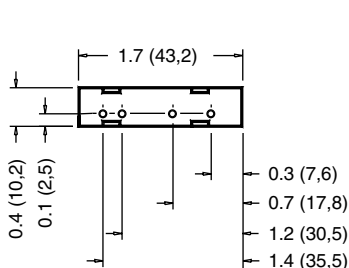
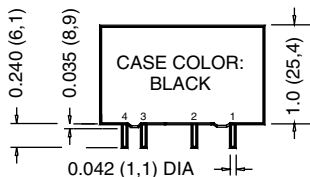

SM SERIES

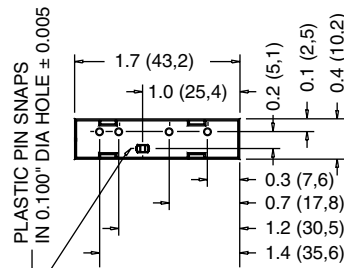
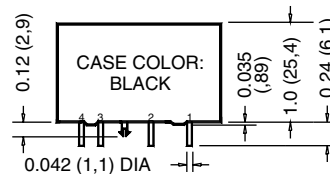

DIMENSIONS: INCHES (MILLIMETERS)
TOLERANCE: ± 0.020 (± 0.50)

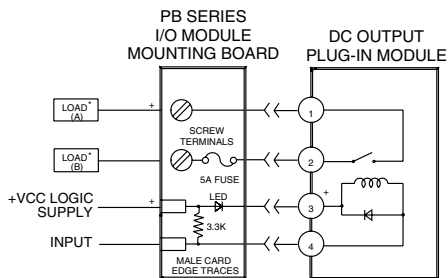

*LOAD MAY BE WIRE IN LOCATION A OR B
ORR MODULES ARE NOT RECOMMENDED FOR SWITCHING INDUCTIVE LOADS. IF USED TO SWITCH INDUCTIVE LOADS, THE LOADS MUST BE DIODE SUPPRESSED TO MINIMIZE DAMAGE TO THE INTERNAL CONTACTS.

ORR, MORR, SMORR EQUIVALENT CIRCUIT

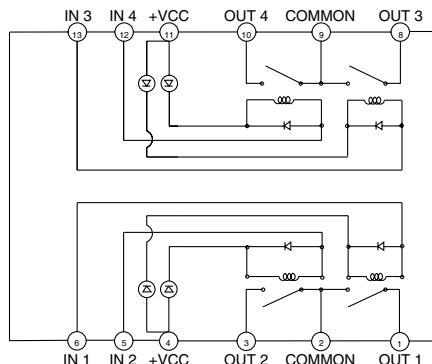

ORR5Q EQUIVALENT CIRCUIT

Products and specifications subject to change without notice.

Order/Technical Support – Tel: (800) 677-5311 / FAX: (800) 677-3865 / www.crouzet-usa.com

DIGITAL I/O MODULES

0.6 INCH, M, SM AND QUAD-PACK REED RELAY OUTPUT MODULES

INPUT SPECIFICATIONS: (1)

Model Number	ORR5 MORR5 SMORR5 ORR5Q	ORR24 MORR24 SMORR24	Units
Nominal Voltage	5.0	24	VDC
Minimum Pick-up Voltage	3.0	18	VDC
Maximum Voltage	8.0	32	VDC
Drop-out Voltage	1.0	1.0	VDC
Maximum Current (2)	32	16	mA
Nominal Resistance (3)	250	2K	Ohms

OUTPUT SPECIFICATIONS: (1) All Devices

Maximum Voltage	575 VAC/VDC
Maximum Peak Off-State Voltage	1500 Vpeak
Maximum Off-State Leakage (4)	1 μ A
Maximum Current	1.0 Amp AC/DC
Maximum Power	25 Volt-Amp
Maximum Contact Resistance (5)	200 mOhms

GENERAL SPECIFICATIONS: (1) All Devices

Operating Temperature Range	-20 to 80°C
Storage Temperature Range	-40 to 100°C
Maximum Pick-up Time (6)	0.5 mSec
Maximum Drop-out Time (7)	0.1 mSec
Input/Output Isolation (8)	2500 VAC
Input/Output Capacitance (typical)	8 pF
Load Circuit Frequency Range	DC to 10 KHz
Life Expectancy (9)	10 million operations

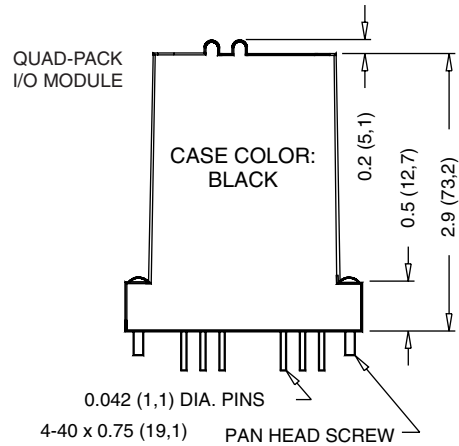

Notes:

- (1) Specifications apply to an ambient temperature of -20 to 80°C unless otherwise noted.
- (2) At maximum input voltage, 25°C.
- (3) +/-10%, 25°C.
- (4) At maximum voltage and 25°C.
- (5) Measured at maximum current, 25°C.
- (6) Measured at minimum input voltage, maximum load circuit voltage, 25°C.
- (7) Measured at maximum input voltage, maximum load circuit voltage, 25°C.
- (8) At 25°C for 1 second maximum duration.
- (9) At 10 VA, 50% duty cycle, one operation per second, 25°C.

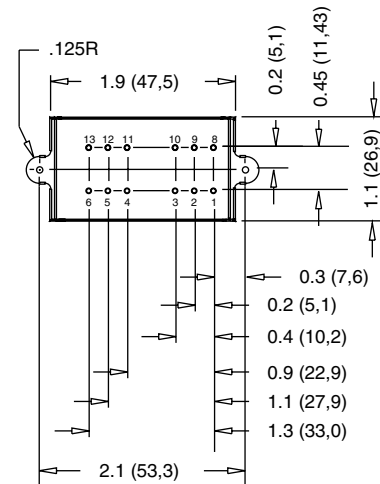

DIMENSIONS: INCHES (MILLIMETERS)
TOLERANCE: ± 0.020 (± 0.50)

Products and specifications subject to change without notice.

Order/Technical Support – Tel: (800) 677-5311 / FAX: (800) 677-3865 / www.crouzet-usa.com

DIGITAL I/O MODULES

C4 INPUT MODULES



FEATURES:

- CE Compliant
- Built-in LED Status Indicator
- Regulated Supply Voltage
- New Industry Standard Packaging
- 4000 VAC Optical Isolation
- AC and DC Inputs
- UL and CSA

SCHEMATIC:

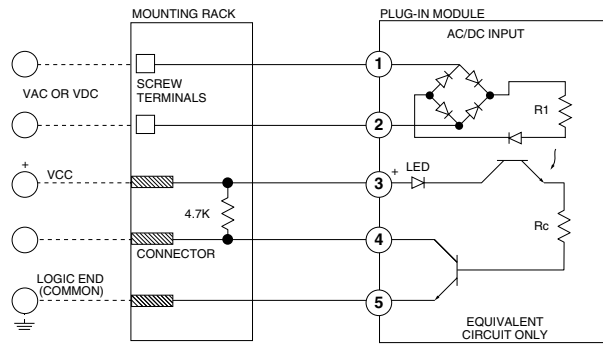

C4 SERIES I/O MODULES
AC/DC INPUT SCHEMATIC

DIMENSIONS:

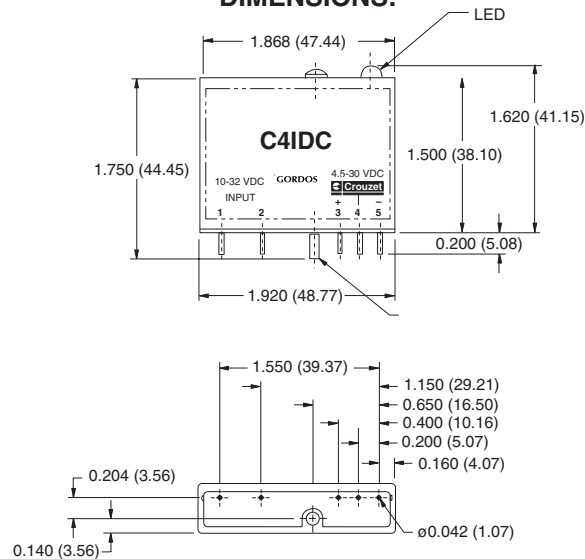

Products and specifications subject to change without notice.

Order/Technical Support – Tel: (800) 677-5311 / FAX: (800) 677-3865 / www.crouzet-usa.com

DIGITAL I/O MODULES

C4 INPUT MODULES

SPECIFICATIONS:

INPUT SPECIFICATIONS: (1)

	C4IAC	C4IACA	C4IDC	C4IDCB	C4IDCG	C4IDCK
Nominal Voltage	120 VAC	240 VAC	10-32 VDC	4-16 VDC	35-60 VDC	2.5-16 VDC
Maximum Voltage	140 VAC	280 VAC	32 VDC	16 VDC	60 VDC	16 VDC
Minimum Voltage	90 VAC	140 VAC	10 VDC	4 VDC	35 VDC	2.5 VDC
Resistance (2) (3)	22 kΩ	75 kΩ	2 kΩ	400 Ω	10 kΩ	300 Ω
Maximum Current (4)	14 mA	5 mA	20 mA	40 mA	10 mA	60 mA
Drop out Current (5)	3 mA	1 mA	1.5 mA	2 mA	1 mA	2 mA
Input Allowed for No Output (6)	2.5 mA/50 VAC	.7 mA/50 VAC	1 mA/3 VDC	.7 mA/1 VAC	.7 mA / 7 VDC	.2 mA / 1 VDC
Maximum Turn-on Time (12)	20 ms	20 ms	5 ms	50 μs	10 ms	25 μs
Maximum Turn-off Time (12)	20 ms	20 ms	5 ms	100 μs	10 ms	25 μs

OUTPUT SPECIFICATIONS: (1)

	C4IAC C4IACA C4IDC	C4IDCB C4IDCG C4IDCK
Logic Supply Voltage	4.5 to 30 VDC	
Maximum Logic Supply Voltage	30 VDC	
Minimum Logic Supply Voltage	4.5 VDC	
Maximum Logic Supply Current (7)	25 mA	
Maximum Supply Idle Current (8)	7 mA	
Maximum Current (9)	50 mA	
Maximum Logic Leakage Current (10)	10 μA	
Maximum Output Voltage Drop (11)	0.2 VDC	

GENERAL SPECIFICATION: (1)

Operating Temperature Range	-30 to +80°C
Storage Temperature Range	-40 to +100°C
Input to Output Isolation Voltage (13)	4000 VAC

ORDERING INFORMATION:

PART NUMBER	INPUT	DC OUTPUT LOGIC
C4IAC	90-140 VAC	4.5 to 30 VDC
C4IACA	140-280 VAC	4.5 to 30 VDC
C4IDC	10-32 VDC	4.5 to 30 VDC
C4IDCB	4-16 VDC	4.5 to 30 VDC
C4IDCG	35-60 VDC	4.5 to 30 VDC
C4IDCK	2.5-16 VDC	4.5 to 30 VDC

Notes:

- (1) Specifications apply to an ambient temperature of -30 to 80°C unless otherwise noted.
- (2) Resistance values for C4IAC modules are effective impedance values at 25°C.
- (3) Resistance values are +/-10% at 25°C.
- (4) At max turn-on voltage, TA=25°C
- (5) For on-state condition to off-state condition, TA=25°C. Higher currents may result in the output remaining in the "on" state.
- (6) Defined as the maximum current/voltage allowed through the module's input that will not switch the module's output state from "off" to "on."
- (7) At maximum logic supply voltage and 25°C.
- (8) At maximum specified logic voltage and 25°C.
- (9) Maximum allowable sinking current through open collector output transistor.
- (10) At maximum output voltage and 25°C.
- (11) At maximum allowable output current and 25°C.
- (12) At 15 VDC logic, 30 VDC output, 50 mA, 25°C and nominal input voltage.
- (13) At 25°C for 1 second maximum duration.

Products and specifications subject to change without notice.

Order/Technical Support – Tel: (800) 677-5311 / FAX: (800) 677-3865 / www.crouzet-usa.com

DIGITAL I/O MODULES

C4 OUTPUT MODULES



FEATURES:

- CE Compliant
- Built-in LED Status Indicator
- Replacable 2 AG Type Fuse
- New Industry Standard Packaging
- UL and CSA
- 4 to 32 VDC Regulated Input

SCHEMATIC:

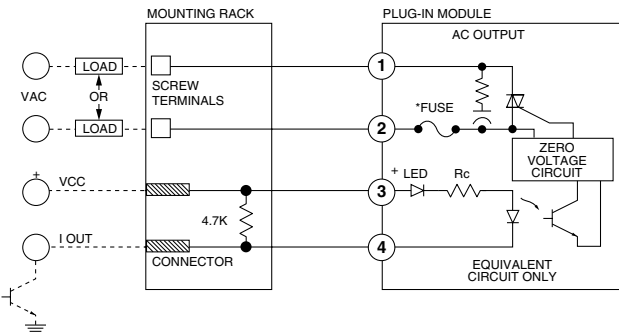

C4 SERIES I/O MODULES
AC OUTPUT SCHEMATIC
* LITTLE FUSE 229003S

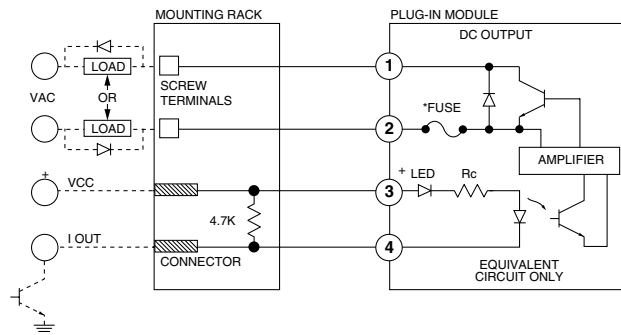

C4 SERIES I/O MODULES
DC OUTPUT SCHEMATIC
* LITTLE FUSE 229003S

DIMENSIONS:

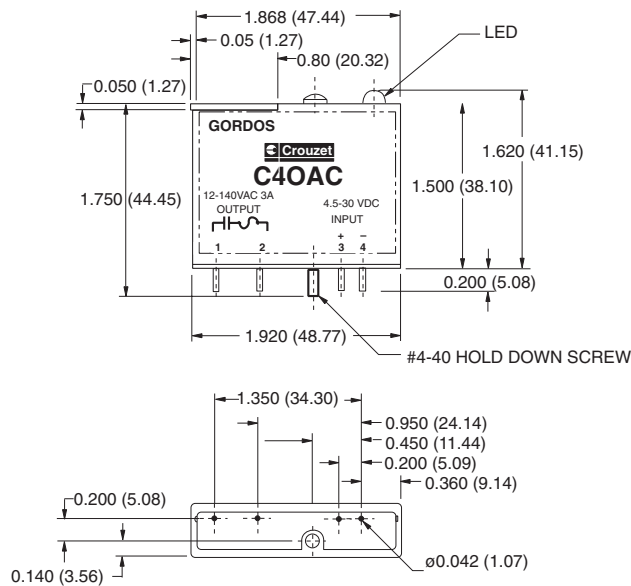

Products and specifications subject to change without notice.

Order/Technical Support – Tel: (800) 677-5311 / FAX: (800) 677-3865 / www.crouzet-usa.com

DIGITAL I/O MODULES

C4 OUTPUT MODULES

SPECIFICATIONS:

INPUT SPECIFICATIONS: (1)

	C4OAC C4OACA	C4OACR C4OACAR	C4ODCA C4ODC
Nominal Voltage	4-32VDC		4-32VDC
Drop-out Voltage	1VDC		1VDC
Maximum Current (2) (3)	22 mA		16 mA
Resistance	Regulated Input		

OUTPUT SPECIFICATIONS: (1)

	C4OAC C4OACR	C4OACA C4OACAR	C4ODC	C4ODCA
Nominal Line Voltage	120 VAC	240 VAC	5-48 VDC	5-150 VDC
Minimum Line Voltage	12 VAC	12 VAC	5 VDC	3 VDC
Maximum Line Voltage	140 VAC	280 VAC	60 VDC	250 VDC
Maximum Off-state Voltage (4)	600 V Peak	600 V Peak	60 VDC	250 VDC
Maximum Off-state Leakage (5)	.1 mA	.1 mA	10 µA	100 µA
Static Off-state dv/dt (6)	200 V / µs	200 V / µs	n/a	n/a
Maximum Output Current (7)	3 A	3 A	3 A	1 A
Minimum Output Current	50 mA	50 mA	10 mA	10 mA
Maximum Surge Current (8)	100 A Peak	100 A Peak	5 A Peak	5 A Peak
On-State Voltage Drop (9)	1.6 V Peak	1.6 V Peak	1.6 VDC	1.6 VDC
HP Rating	1/4 HP	1/4 HP	n/a	n/a

GENERAL SPECIFICATION: (1)

	C4OAC C4OACA	C4OACR C4OACAR	C4ODC C4ODCA	
Operating Temperature Range	-30 to +80	-30 to +80	-30 to +80	C
Storage Temperature Range	-40 to +100	-40 to +100	-40 to +100	C
Maximum Turn-on Time (10)	8.33	0.1	0.05	mSec
Maximum Turn-off Time	8.33	8.33	0.05	mSec
Input to Output Isolation Voltage (11)	4000	4000	4000	VAC
Input/Output Capacitance	4	4	4	pF

ORDERING INFORMATION:

PART NUMBER	INPUT	OUTPUT
C4ODC	4-32VDC	5-60VDC
C4ODCA	4-32VDC	5-250VDC
C4OAC	4-32VDC	12-140VAC
C4OACA	4-32VDC	24-280VAC
C4OACR	4-32VDC	12-140VAC
C4OACAR	4-32VDC	24-280VAC

Notes:

- (1) Specifications apply to an ambient temperature of -30 to 80°C unless otherwise noted.
- (2) At 32 VDC typical.
- (3) 13 mA at 5 VDC for AC output models only.
- (4) Maximum 1 minute duration.
- (5) At maximum rated line voltage, TA=80°C.
- (6) Minimum DVI/DT per EIA/NARM RS443, method RS397. DVI/DT ratings do not apply to C4ODC.
- (7) Without any external heat sink in still air, TA=45°C, at 40°C derate 40 mA/°C to 80°C.
- (8) At 25°C, maximum duration: 1AC cycle for AC modules, 1 second for DC module.
- (9) At peak rated current.
- (10) Before zero voltage, Vin=4V AC modules only based on 60 Hz. Vin=15V for DC module.
- (11) For 1 second maximum duration TA=25°C.

Products and specifications subject to change without notice.

Order/Technical Support – Tel: (800) 677-5311 / FAX: (800) 677-3865 / www.crouzet-usa.com



Products and specifications subject to change without notice.

Order/Technical Support – Tel: (800) 677-5311 / FAX: (800) 677-3865 / www.crouzet-usa.com

DIGITAL I/O MODULES

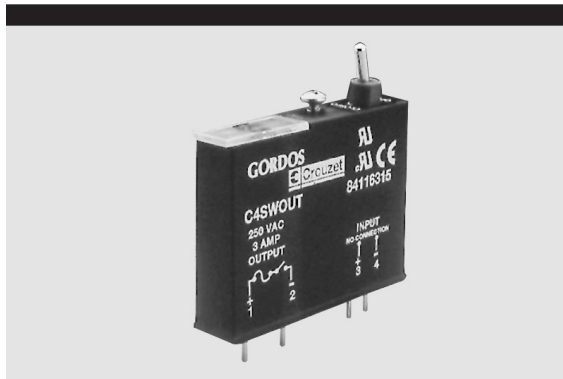

C4 INPUT SWITCH

OUTPUT SPECIFICATIONS:

Logic Supply Voltage 4.5 to 30 VDC
 Maximum Output Current 50 mA

C4 OUTPUT SWITCH

OUTPUT SPECIFICATIONS:

3 Amps rms @ 250 VAC

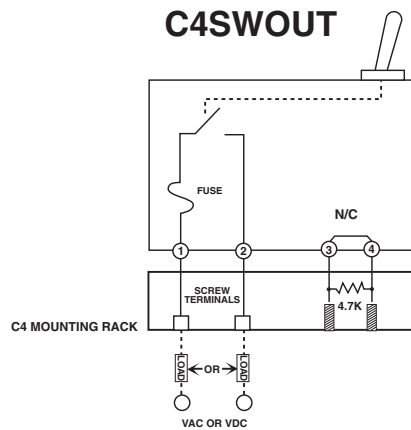
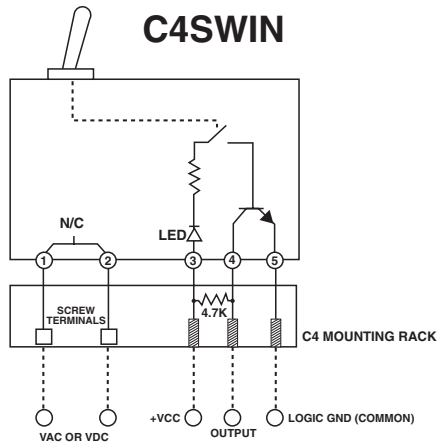

ORDERING INFORMATION:

PART NUMBER

C4SWIN INPUT MODULE
 C4SWOUT OUTPUT MODULE

Products and specifications subject to change without notice.

Order/Technical Support – Tel: (800) 677-5311 / FAX: (800) 677-3865 / www.crouzet-usa.com

DIGITAL I/O MODULES

DIN-RAIL MOUNTABLE INPUT MODULES

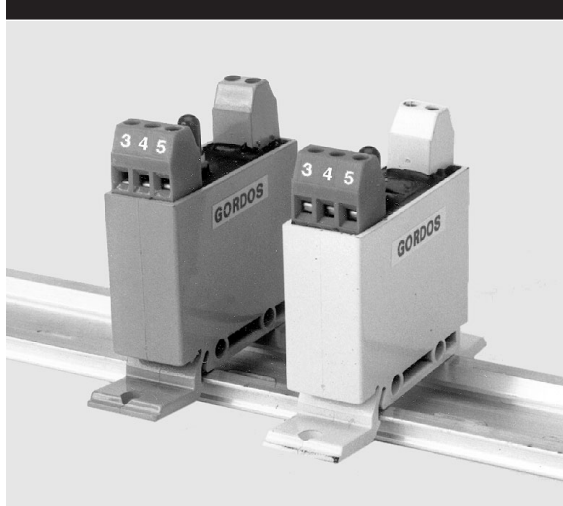

FEATURES:

- CE Compliant
- DIN-Rail Mountable Single Point Input Modules
- AC Inputs for 24 V, 120 V, 240 V
- DC Inputs for 3.3 to 32 V, 10 to 48 V
- UL Recognized (E46203)/CSA Certified (38595)
- 4 kV Optical Isolation
- Open-Collector Output, with LED Indicator
- Input and Output Barrier Strips Accept 14 to 28 AWG Wire
- Configured for Panel Mounting

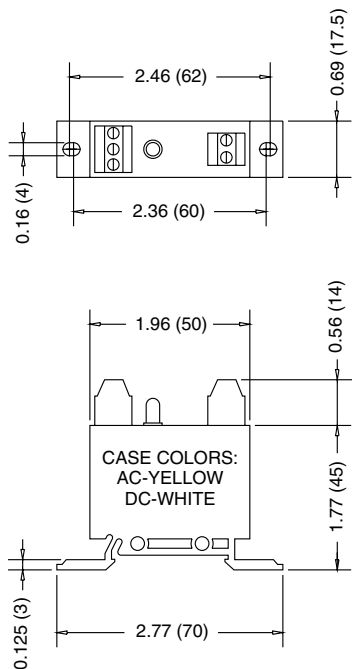

DIMENSIONS: INCHES (MILLIMETERS)
TOLERANCE: ± 0.020 (± 0.50)

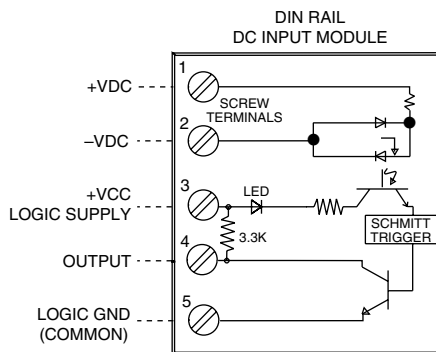
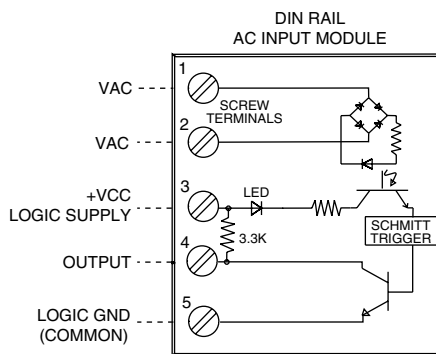

(EQUIVALENT CIRCUIT DIAGRAMS)

Products and specifications subject to change without notice.

Order/Technical Support – Tel: (800) 677-5311 / FAX: (800) 677-3865 / www.crouzet-usa.com

DIGITAL I/O MODULES

DIN-RAIL MOUNTABLE INPUT MODULES

INPUT SPECIFICATIONS: (1)

Model Number	DRIAC5 DRIAC24	DRIAC5A DRIAC24A	DRIDC5 DRIDC24	DRIDC5A DRIDC24A
Parameter				
Nominal Voltage	120 VAC	240 VAC	5-28 VDC	12-48 VDC
Maximum Voltage	140 VAC/VDC	280 VAC/VDC	32 VDC/VAC	48 VDC
Minimum Voltage	90 VAC/VDC	180 VAC/VDC	4.0 VDC/VAC	10 VDC
Resistance (2)	28 kΩ	75 kΩ	1 kΩ	2 kΩ
Maximum Current (3)	5.0 mArms	5.0 mArms	34 mA	34 mA
Drop-out Current (4)	2.0 mArms	1.5 mArms	1.0 mA	1.0 mA
Allowable Current/	2.5 mArms	2.0 mArms	1.5 mA	1.5 mA
Voltage for No Output (5)	50 VAC/VDC	50 VAC/VDC	2.0 VDC	4.0 VDC

OUTPUT SPECIFICATIONS: (1)

Model Number	DRIAC5 DRIAC5A DRIDC5 DRIDC5A	DRIAC24 DRIAC24A DRIDC24 DRIDC24A	Units
Parameter			
Nominal Logic Supply Voltage	5.0	24.0	VDC
Maximum Logic Supply Voltage	6.0	30.0	VDC
Minimum Logic Supply Voltage	3.0	20.0	VDC
Maximum Logic Supply Current (6)	28.0	28.0	mA
Maximum Logic Supply Leakage Current (7)	10.0	10.0	μA
Maximum Voltage (8)	30.0	30.0	VDC
Maximum Current (9)	50.0	50.0	mA
Maximum Leakage Current (10)	10.0	10.0	μA
Maximum Voltage Drop (11)	0.2	0.2	VDC

GENERAL SPECIFICATIONS: (1)

Model Number	DRIAC5 DRIAC5A DRIAC24 DRIAC24A	DRIDC5 DRIDC5A DRIDC24 DRIDC24A	Units
Parameter			
Operating Temperature Range	-30 to 80	-30 to 80	°C
Storage Temperature Range	-40 to 100	-40 to 100	°C
Maximum Turn-on Time (12)	20	1.0	mSec
Maximum Turn-off Time (12)	30	1.0	mSec
Input/Output Isolation Voltage (13)	4000	4000	VAC
Input/Output Capacitance (typical)	8	8	pF
Line Frequency Range	47 to 63	DC	Hertz

TABLE OF MODEL NUMBER SUFFIXES IDENTIFYING OPTIONAL FEATURES

Suffix	Feature
A	High voltage versions (240 VAC for AC modules), (48 VDC for DC modules).

Notes:

- (1) Specifications apply to an ambient temperature of -30 to 80°C unless otherwise noted.
- (2) Resistance values for IAC modules are effective impedance values at 25°C.
- (3) Measured at maximum specified input voltage, 25°C.
- (4) Defined as the maximum current allowed through the module's input to guarantee that the output will switch from "on" to "off." Higher currents may result in the output remaining in the "on" state.
- (5) Defined as the maximum current allowed through the module's input that will not switch the module's output state from "off" to "on."
- (6) At maximum specified logic supply voltage and 25°C.
- (7) At maximum specified logic voltage and 25°C.
- (8) Maximum allowable applied voltage across open collector output transistor. Factory recommends this voltage not exceed logic voltage.
- (9) Maximum allowable sinking current through open collector output transistor.
- (10) At maximum output voltage and 25°C.
- (11) At maximum allowable output current and 25°C.
- (12) At nominal logic supply voltage, 25 mA output sinking current, nominal input voltage and 25°C.
- (13) At 25°C for 1 second maximum duration.

Products and specifications subject to change without notice.

Order/Technical Support – Tel: (800) 677-5311 / FAX: (800) 677-3865 / www.crouzet-usa.com

DIGITAL I/O MODULES

DIN-RAIL MOUNTABLE OUTPUT MODULES

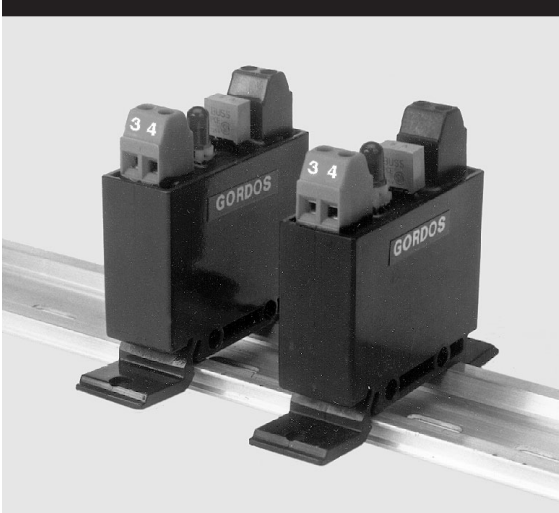

FEATURES:

- CE Compliant
- DIN-Rail Mountable Single Point Output Modules (35mm DIN)
- UL Recognized/Horse Power Rated (E46203)/ CSA certified (38595)
- AC Output Rating 5 Amp at 12 to 280 VAC, with 250 Amp Single Cycle Surge Capability
- DC Output Rating 3 Amp at 3 to 60 VDC
- 3 to 32 VDC Input for AC Module, 5V or 24V for DC Module
- Zero Voltage Turn-on for AC Module
- 4 kV Optical Isolation with LED Indicator
- Barrier Strips Accept 14 to 28 AWG Wire
- Configured for Panel Mounting

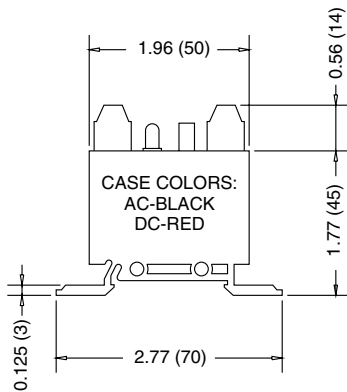
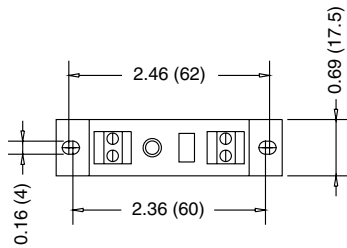

DIMENSIONS: INCHES (MILLIMETERS)
TOLERANCE: ±0.020 (±0.50)

CASE COLORS:
AC-BLACK
DC-RED

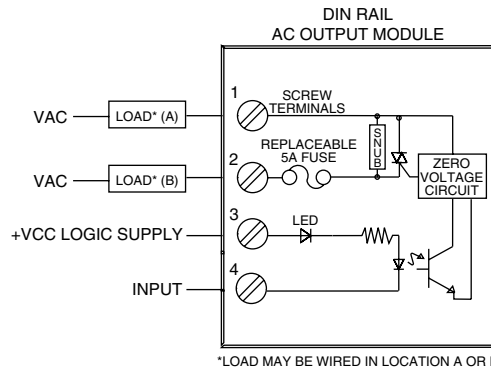

*LOAD MAY BE WIRED IN LOCATION A OR B

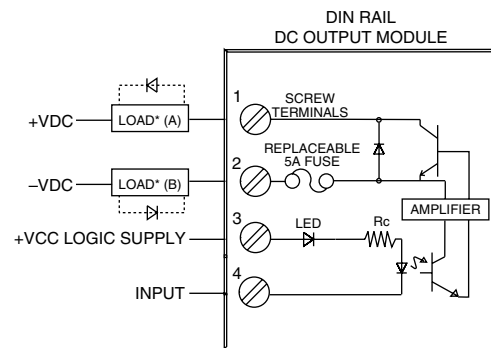

*LOAD MAY BE WIRED IN LOCATION A OR B.
DC INDUCTIVE LOADS MUST BE DIODE SUPPRESSED TO PREVENT DAMAGE TO THE I/O MODULE.

(EQUIVALENT CIRCUIT DIAGRAMS)

Products and specifications subject to change without notice.

Order/Technical Support – Tel: (800) 677-5311 / FAX: (800) 677-3865 / www.crouzet-usa.com

DIGITAL I/O MODULES

DIN-RAIL OUTPUT MODULES

INPUT SPECIFICATIONS: (1)

Model Number	DROAC	DRODC5	DRODC24	Units
Parameter				
Nominal Voltage	5-24	5.0	24.0	VDC
Minimum Voltage	3.7	3.5	18.0	VDC
Maximum Voltage	32	8.0	32.0	VDC
Drop-Out Voltage	1.0	1.0	1.0	VDC
Maximum Current (2)	18.0	18.0	13.0	mA
Resistance (3)	—	250	2000	Ohms

OUTPUT SPECIFICATIONS: (1)

Model Number	DROAC	DRODC5 DRODC24
Parameter		
Nominal Line Voltage	120/240 VAC	5-48 V
Minimum Line Voltage	12 VAC	3.0 V
Maximum Line Voltage	280 VAC	60 V
Max Off-State Voltage (4)	600 Vpeak	60 V
Max Off-State Leakage (5)	.1 mArms	10 μ A
Static Off-State dv/dt (6)	200 V / μ sec	N/A
Maximum Rated On-State Current (7)	5.0 Arms	3.0 A
Min On-State Current	50 mArms	10 mA
Max Surge Current (8)	250 Apeak	5.0 A
On-State Voltage Drop (9)	1.6 V	1.5 V
Horse Power Rating (13)	1/2 H.P.	N/A

GENERAL SPECIFICATIONS: (1)

Model Number	DROAC	DRODC5 DRODC24	Units
Parameter			
Operating Temperature Range	-30 to 80	-30 to 80	$^{\circ}$ C
Storage Temperature Range	-40 to 100	-40 to 100	$^{\circ}$ C
Maximum Turn-on Time (10)	8.33	0.1	mSec
Maximum Turn-off Time (10)	8.33	0.75	mSec
Input/Output Isolation Voltage (11)	4000	4000	VAC
Input/Output Capacitance (typical)	8	8	pF
Line Frequency Range	47 to 63	DC	Hertz
Fuse (12)	5	5	Amps

Notes:

- (1) Specifications apply to an ambient temperature of -30 to 80 $^{\circ}$ C unless otherwise noted.
- (2) At nominal input voltage for DC modules, AC modules are current limited +/-10% at 25 $^{\circ}$ C.
- (3) +/-10% at 25 $^{\circ}$ C for DC modules.
- (4) Maximum 1 minute duration for OAC modules when applied as a DC voltage rather than peak AC voltage.
- (5) At maximum line voltage, 25 $^{\circ}$ C for OAC modules, and 80 $^{\circ}$ C for ODC modules.
- (6) Minimum dv/dt per EIA/NARM RS443, method RS397. dv/dt ratings do not apply to ODC modules.
- (7) At 40 $^{\circ}$ C, derate OAC modules by 125 mA/ $^{\circ}$ C to 80 $^{\circ}$ C; derate ODC modules by 50 mA/ $^{\circ}$ C to 80 $^{\circ}$ C.
- (8) At 25 $^{\circ}$ C. Maximum duration: 1 AC cycle for OAC modules, 1 second for ODC modules.
- (9) At maximum rated on-state current and 25 $^{\circ}$ C.
- (10) At maximum line voltage, maximum rated output current, nominal input voltage, 25 $^{\circ}$ C. Switching speed of OAC modules based upon 60 Hz line frequency.
- (11) At 25 $^{\circ}$ C for 1 second maximum duration.
- (12) Fuse is Buss, PC-TRON #PCE5.
- (13) 1/2 H.P. at 240 VAC, 1/4 H.P. at 120 VAC.

Products and specifications subject to change without notice.

Order/Technical Support – Tel: (800) 677-5311 / FAX: (800) 677-3865 / www.crouzet-usa.com

DIGITAL I/O MODULES

17.5mm DIN-RAIL OUTPUT MODULES

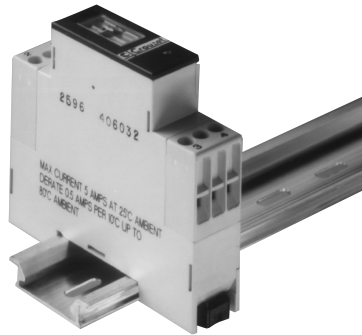

FEATURES:

- UL and cUL (E46203) Recognized
- CE Compliant
- DIN-Rail Mountable (17.5mm wide) Single Point Output Modules
- AC Output Rating 5 Amp at 12 to 280 VAC, with 350 Amp Single Cycle Surge Capability
- DC Output Rating 3 Amp at 5 to 60 VDC
- 4 to 32 VDC Input Current regulated
- Zero Voltage Turn-on for AC Module
- 4 kV Optical Isolation with LED Indicator
- Barrier Strips Accept 14 to 28 AWG Wire
- Configured for Panel Mounting

OUTPUT SPECIFICATIONS: (1)

Model Number	84130105 84130108	84130104
Parameter		
Nominal Line Voltage	120/240 VAC	5-60 VDC
Minimum Line Voltage	12 VAC	5 VDC
Maximum Line Voltage	280 VAC	60 VDC
Max Off-State Voltage (3)	800 Vpeak	60 VDC
Max Off-State Leakage (4)	.1 mA	10 μ A
Static Off-State dv/dt (5)	50 V / μ sec	N/A
Maximum Rated On-State Current (6)	5.0 Arms	3.0 A
Min On-State Current	50 mArms	10 mA
Max Surge Current (7)	350 Apeak	5.0 A
On-State Voltage Drop (8)	1.85 Vpeak	1.6 VDC

INPUT SPECIFICATIONS: (1)

Model Number	84130104	84130105
Parameter		
Nominal Voltage	4-32 VDC	
Minimum Voltage	4 VDC	
Maximum Voltage	32 VDC	
Drop-Out Voltage	1 VDC	
Maximum Current (2)	22 mA	
Resistance	Current Regulated	

DIMENSIONS:

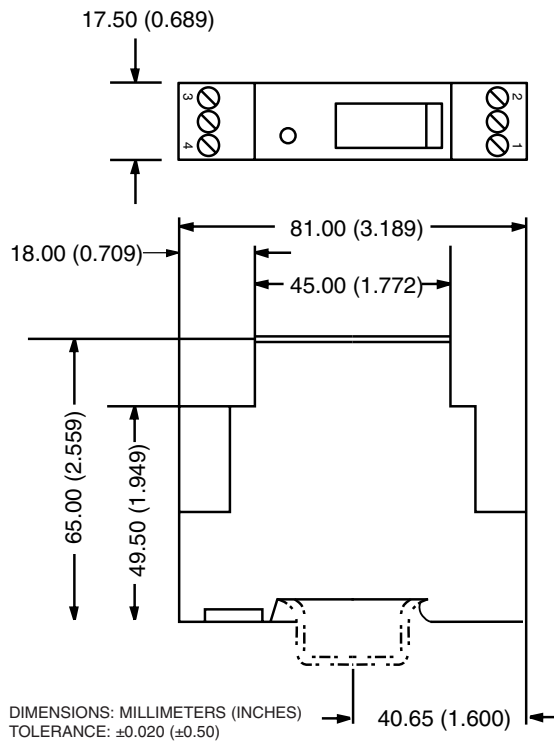

GENERAL SPECIFICATIONS: (1)

Model Number	Units	84130105	84130104
Operating Temperature Range	$^{\circ}$ C	-30 to 80	-30 to 80
Storage Temperature Range	$^{\circ}$ C	-40 to 100	-40 to 100
Maximum Turn-on Time (9) (11)	mSec	8.33	0.05
Maximum Turn-off Time (9)	mSec	8.33	0.05
Input/Output Isolation Voltage (10)	VAC	4000	4000
Input/Output Capacitance (typical)	pF	6	4
Line Frequency Range	Hertz	47 to 63	DC

Notes:

- (1) Specifications apply to an ambient temperature of -30 to 80 $^{\circ}$ C unless otherwise noted.
- (2) Modules are current limited +/-10% at 25 $^{\circ}$ C.
- (3) Maximum 1 minute duration for OAC modules when applied as a DC voltage rather than peak AC voltage.
- (4) At maximum line voltage, 25 $^{\circ}$ C for OAC modules, and 80 $^{\circ}$ C for ODC modules.
- (5) Minimum dv/dt per EIA/NARMS RS443, method RS397. dv/dt ratings do not apply to ODC modules.
- (6) At 25 $^{\circ}$ C, derate 84130105 modules by 46.9 mA/ $^{\circ}$ C to 80 $^{\circ}$ C; derate 84130104 modules by 21.5 mA/ $^{\circ}$ C to 80 $^{\circ}$ C.
- (7) At 25 $^{\circ}$ C. Maximum duration: 1 AC cycle for OAC modules, 1 second for ODC modules.
- (8) At maximum rated on-state current and 25 $^{\circ}$ C.
- (9) At maximum line voltage, maximum rated output current, nominal input voltage, 25 $^{\circ}$ C. Switching speed of OAC modules based upon 60 Hz line frequency.
- (10) At 25 $^{\circ}$ C for 1 second maximum duration.
- (11) For 84130108 turn-on time is 0.1 mSec.

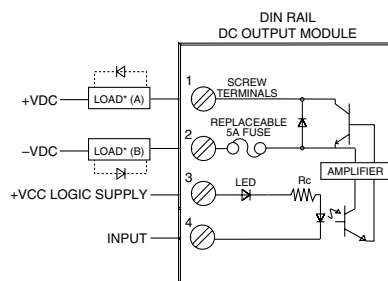

*LOAD MAY BE WIRED IN LOCATION A OR B. DC INDUCTIVE LOADS MUST BE DIODE SUPPRESSED TO PREVENT DAMAGE TO THE I/O MODULE.

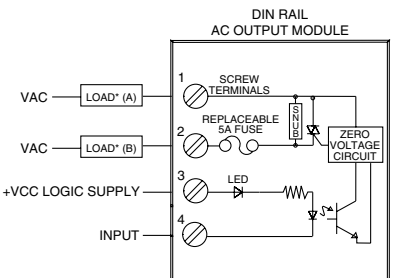

(EQUIVALENT CIRCUIT DIAGRAMS)

Products and specifications subject to change without notice.

Order/Technical Support – Tel: (800) 677-5311 / FAX: (800) 677-3865 / www.crouzet-usa.com

DIGITAL I/O MODULE MOUNTING BOARDS

FEATURES:

- Plug-compatible logic connections on 8, 16, 24 and 32 position boards. Screw terminal barrier block for logic connections on 4-position boards.
- Screw terminal barrier block for load connections
- Resident pull-up resistors
- 5 amp field-replaceable fuses (LITTLEFUSE #251005 or equivalent)
- LEDs indicate logic status
- All even-numbered logic connections are logic ground
- Input and output modules accepted interchangeably
- Operate with 5, 15 or 24 volt logic supplies
- Captive-screw retaining system for standard-size modules and "Quad-Packs." Pin retaining system for "SM" series miniature modules. Optional hold down bar for "M" and "SM" series miniature modules.
- PB4, PB4R, PB8, PB16, PB16S, PB16T, PB24, PB24Q and PB32Q UL recognized and approved for field wiring (E79183) and CSA certified (38595). Additional approvals pending. Consult factory for updated list.

FOR 0.6 INCH MODULES (Compatible with "SM" Series Modules)

PB4

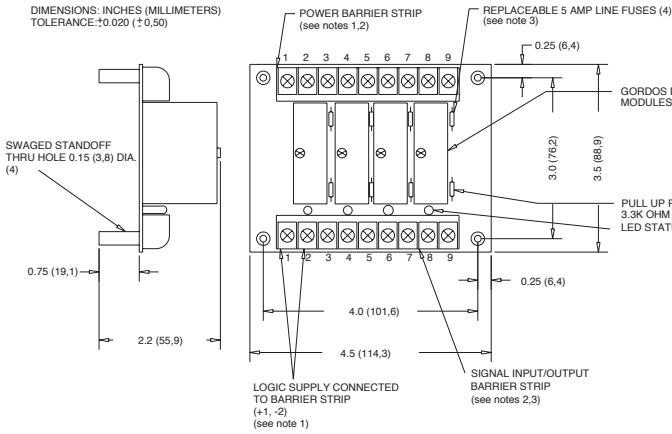

- NOTES: 1) 6-32 SCREW TERMINAL BARRIER STRIPS ACCEPT WIRE SIZES FROM 24 TO 12 AWG.
2) OPTIONAL JUMPERS AVAILABLE TO INTERCONNECT BARRIER STRIP COMMONS. ORDER 1 EACH "JSS" AND CUT IN HALF.
3) LITTLE FUSE #251005 OR EQUIVALENT.

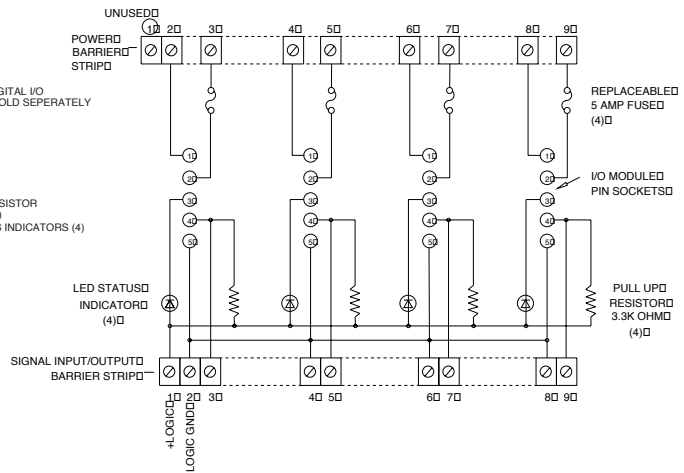

PB4R

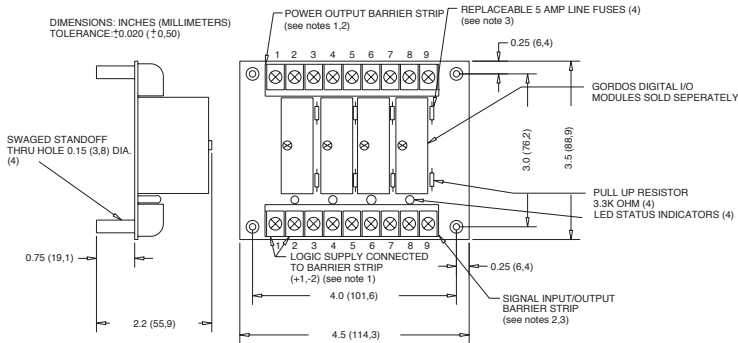

- NOTES: 1) 6-32 SCREW TERMINAL BARRIER STRIPS ACCEPT WIRE SIZES FROM 24 TO 12 AWG.
2) OPTIONAL JUMPERS AVAILABLE TO INTERCONNECT BARRIER STRIP COMMONS. ORDER 1 EACH "JSS" AND CUT IN HALF.
3) LITTLE FUSE #251005 OR EQUIVALENT.
4) PB4R ACCEPTS ONLY OUTPUT MODULES. INPUT MODULES WILL NOT PLUG INTO PB4R.

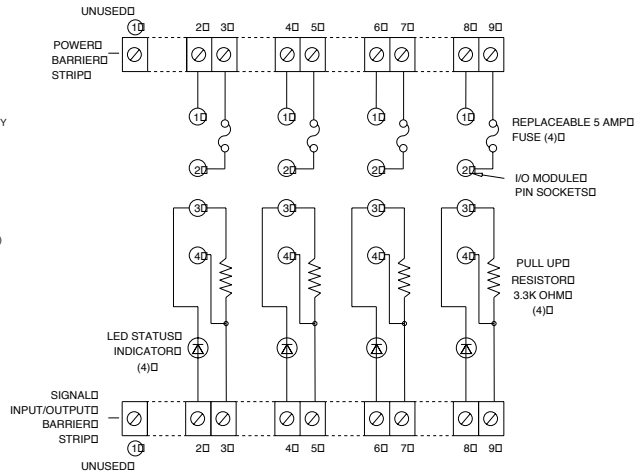

Products and specifications subject to change without notice.

Order/Technical Support – Tel: (800) 677-5311 / FAX: (800) 677-3865 / www.crouzet-usa.com

DIGITAL I/O MODULE MOUNTING BOARDS

FOR 0.6 INCH MODULES (Compatible with "SM" Series Modules)

PB4H

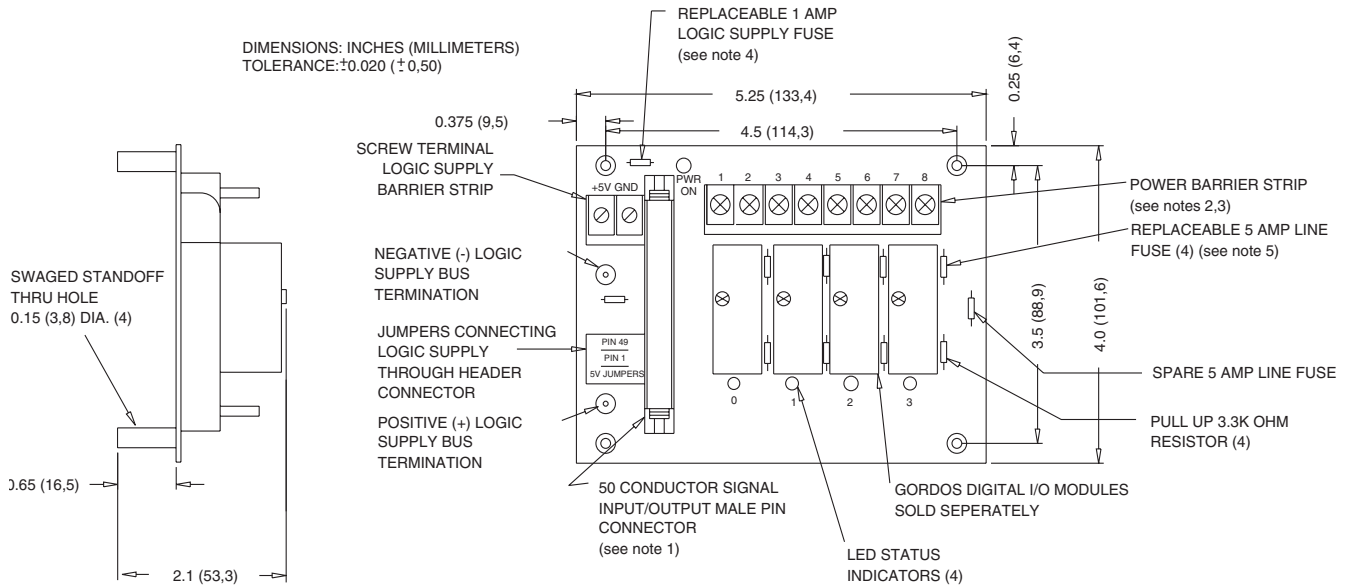

- NOTES: 1) CONNECTOR IS CIRCUIT ASSEMBLY CA-50H-2B-SR OR EQUIVALENT.
 2) 6-32 SCREW TERMINAL BARRIER STRIPS ACCEPT WIRE SIZES FROM 24 TO 12 AWG.
 3) OPTIONAL JUMPERS ARE AVAILABLE TO INTERCONNECT BARRIER STRIP COMMONS. ORDER 1 EACH "JS8" AND CUT IN HALF.
 4) LITTLE FUSE 251001 OR EQUIVALENT.
 5) LITTLE FUSE 251005 OR EQUIVALENT.

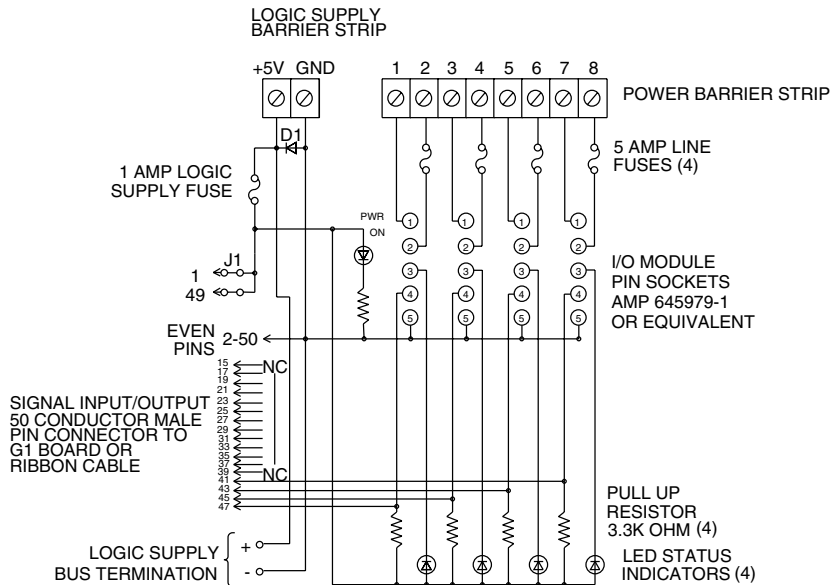

Products and specifications subject to change without notice.

Order/Technical Support – Tel: (800) 677-5311 / FAX: (800) 677-3865 / www.crouzet-usa.com

DIGITAL I/O MODULE MOUNTING BOARDS

FOR 0.6 INCH MODULES (Compatible with "SM" Series Modules)

PB8

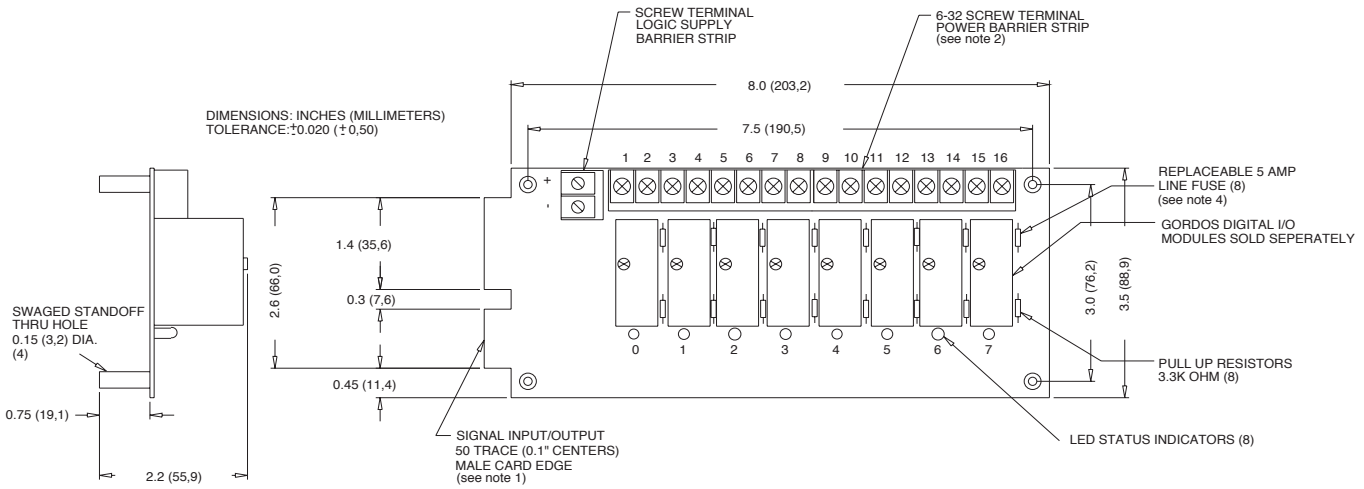

- NOTES: 1) MATING CONNECTOR IS BERG 66317-150 OR EQUIVALENT. SPECIFY SUFFIX "V" FOR OPTIONAL CA26HM-2F-SR CIRCUIT ASSEMBLY OR EQUIVALENT 26 CONDUCTOR PERPENDICULAR-TO-THE-BOARD MALE PIN CONNECTOR.
2) 6-32 SCREW TERMINAL BARRIER STRIPS ACCEPT WIRE SIZES FROM 24 TO 12 AWG.
3) OPTIONAL JUMPERS ARE AVAILABLE TO INTERCONNECT BARRIER STRIP COMMONS. ORDER 1 EACH "JS8".
4) LITTLE FUSE 251005 OR EQUIVALENT.

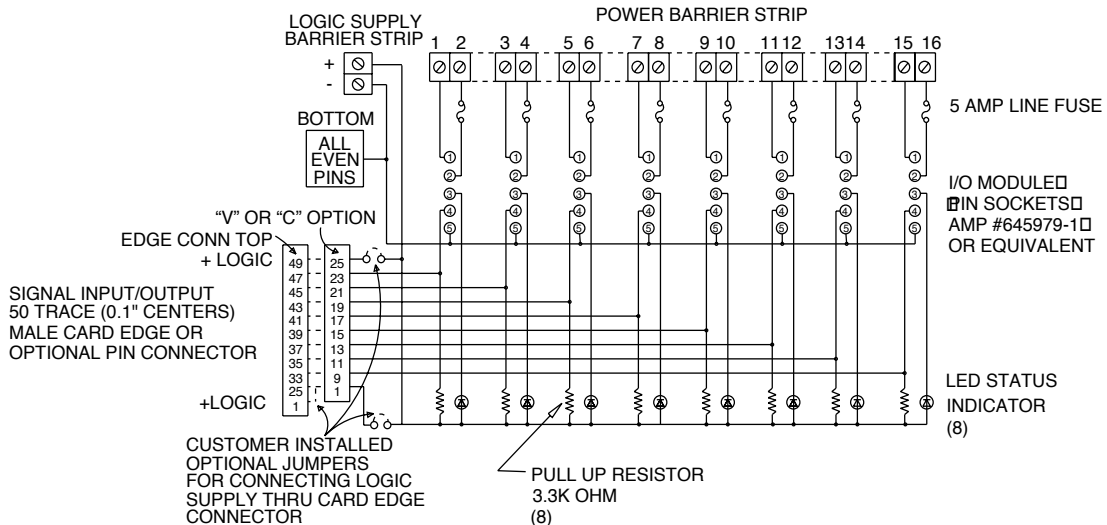

Products and specifications subject to change without notice.

Order/Technical Support – Tel: (800) 677-5311 / FAX: (800) 677-3865 / www.crouzet-usa.com

DIGITAL I/O MODULE MOUNTING BOARDS

FOR 0.6 INCH MODULES (Compatible with "SM" Series Modules)

PB8H

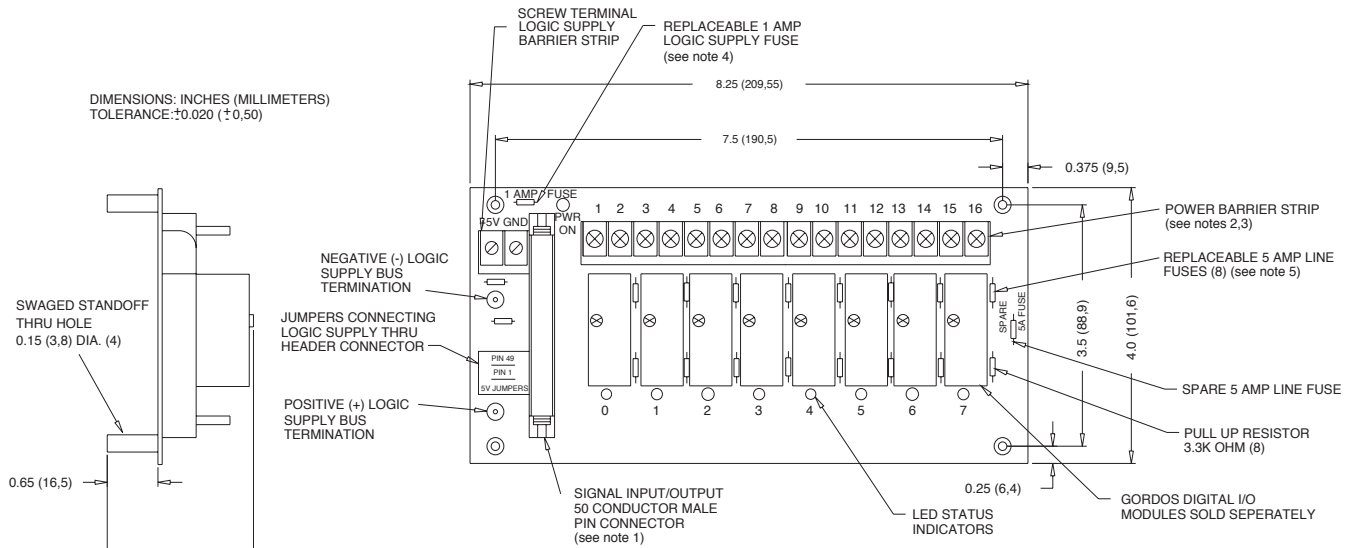

- NOTES: 1) CONNECTOR IS CIRCUIT ASSEMBLY CA-50H-2B-SR OR EQUIVALENT.
2) 6-32 SCREW TERMINAL BARRIER STRIPS ACCEPT WIRE SIZES FROM 24 TO 12 AWG.
3) OPTIONAL JUMPERS ARE AVAILABLE TO INTERCONNECT BARRIER STRIP COMMONS. ORDER 1 EACH "JS8".
4) LITTLE FUSE 251001 OR EQUIVALENT.
5) LITTLE FUSE 251005 OR EQUIVALENT.

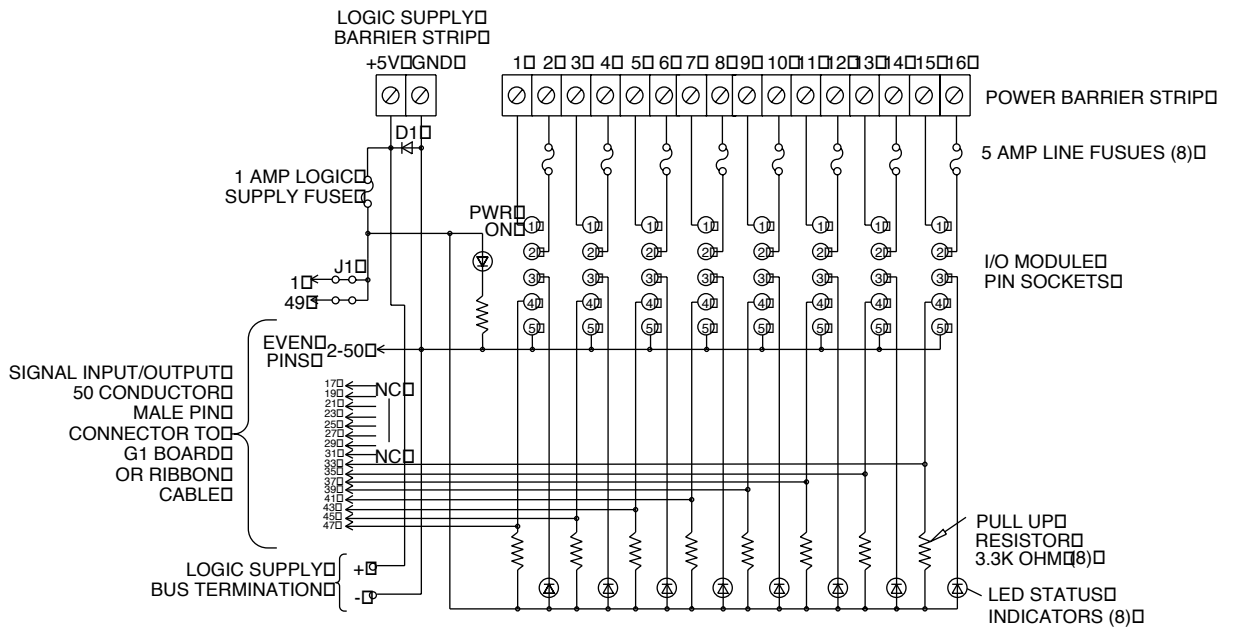

Products and specifications subject to change without notice.

Order/Technical Support – Tel: (800) 677-5311 / FAX: (800) 677-3865 / www.crouzet-usa.com

DIGITAL I/O MODULE MOUNTING BOARDS

FOR 0.6 INCH MODULES (Compatible with "SM" Series Modules)

PB16

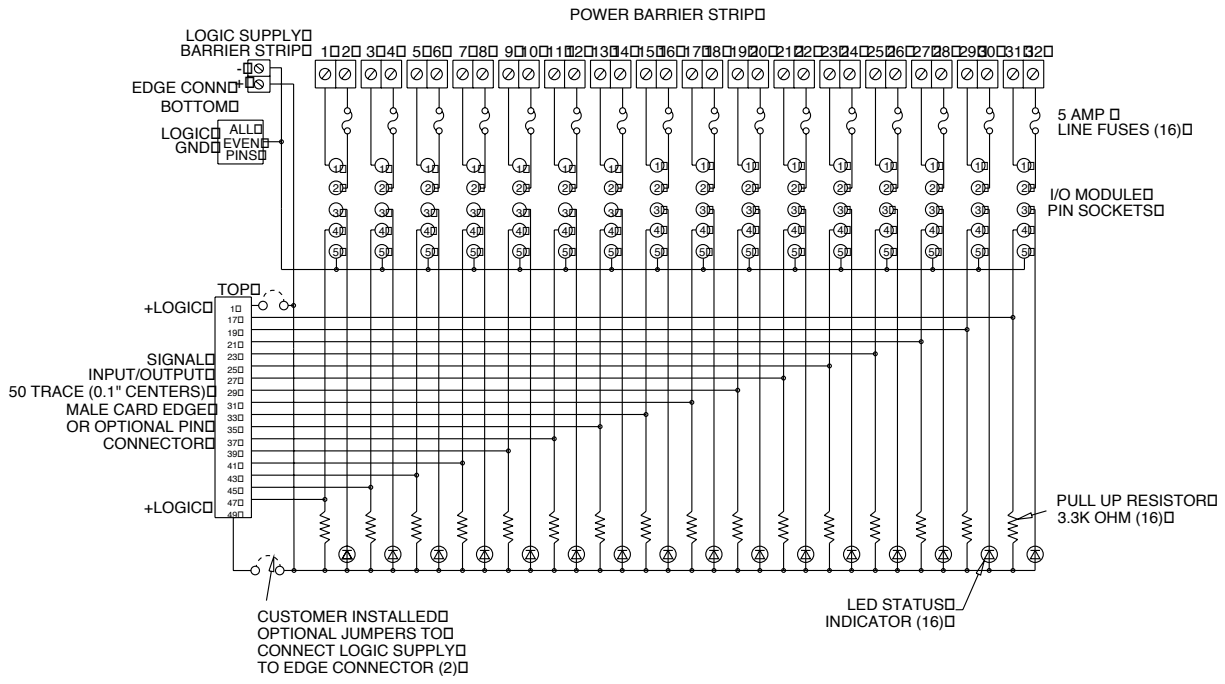
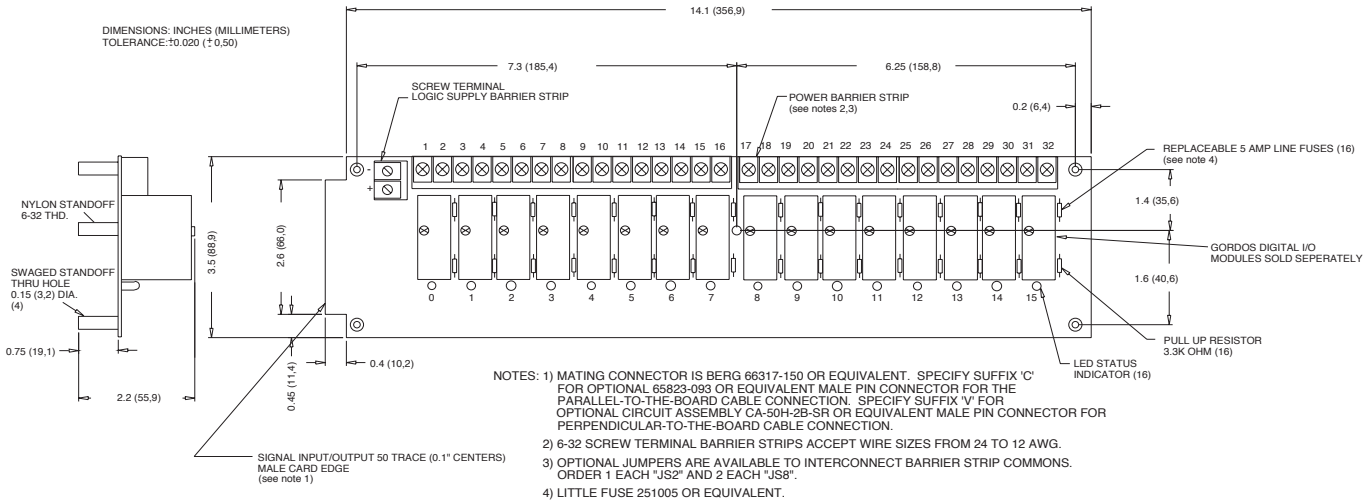

Products and specifications subject to change without notice.

Order/Technical Support – Tel: (800) 677-5311 / FAX: (800) 677-3865 / www.crouzet-usa.com

DIGITAL I/O MODULE MOUNTING BOARDS

FOR 0.6 INCH MODULES (Compatible with "SM" Series Modules)

PB16H

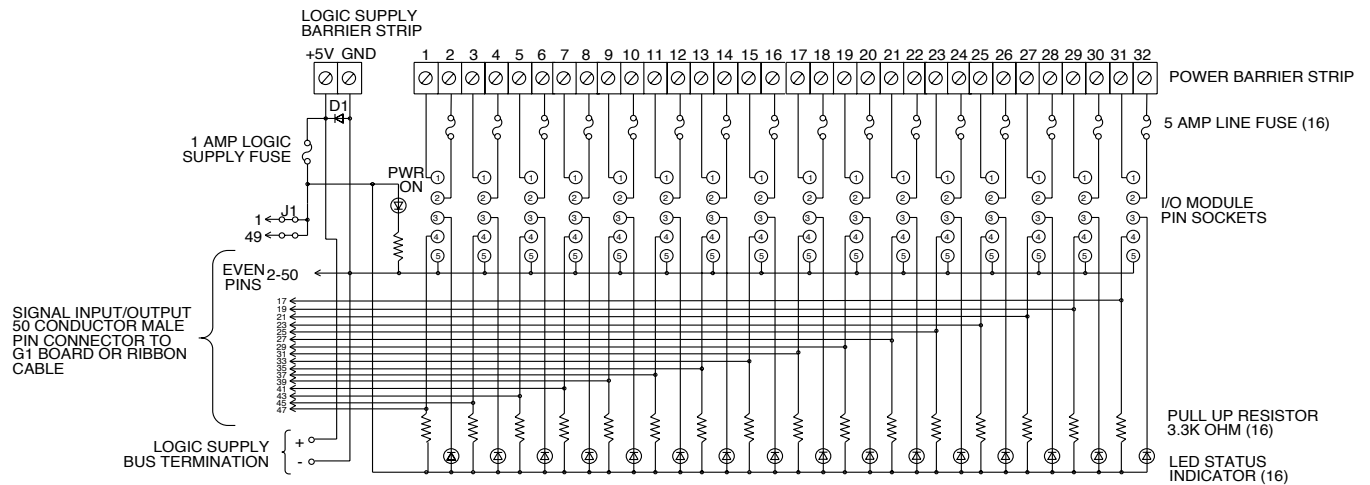
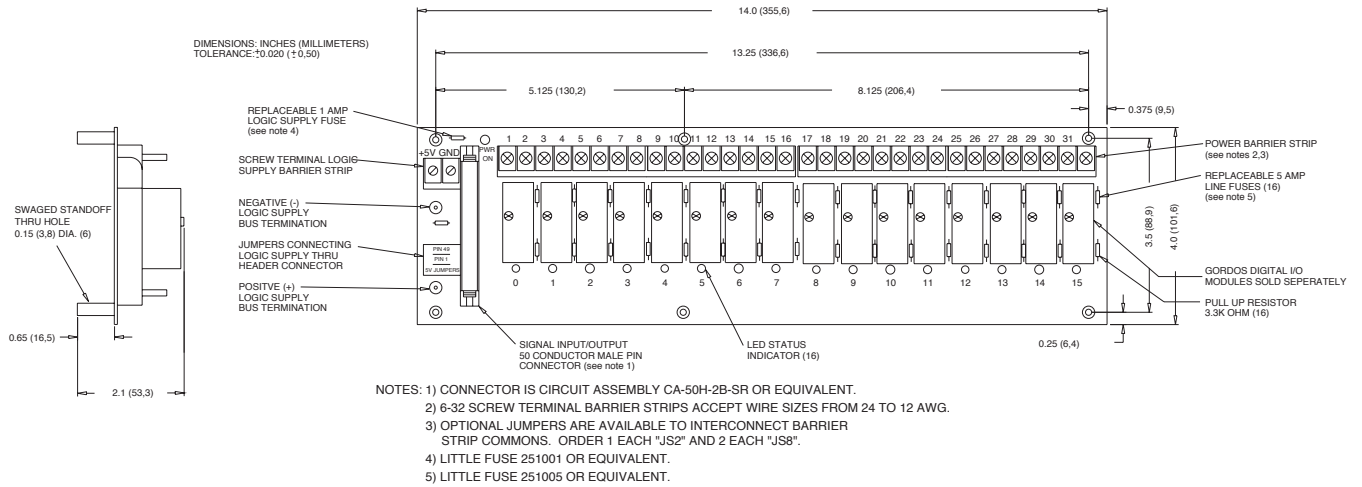

Products and specifications subject to change without notice.

Order/Technical Support – Tel: (800) 677-5311 / FAX: (800) 677-3865 / www.crouzet-usa.com

DIGITAL I/O MODULE MOUNTING BOARDS

FOR 0.6 INCH MODULES (Compatible with "SM" Series Modules)

PB16S

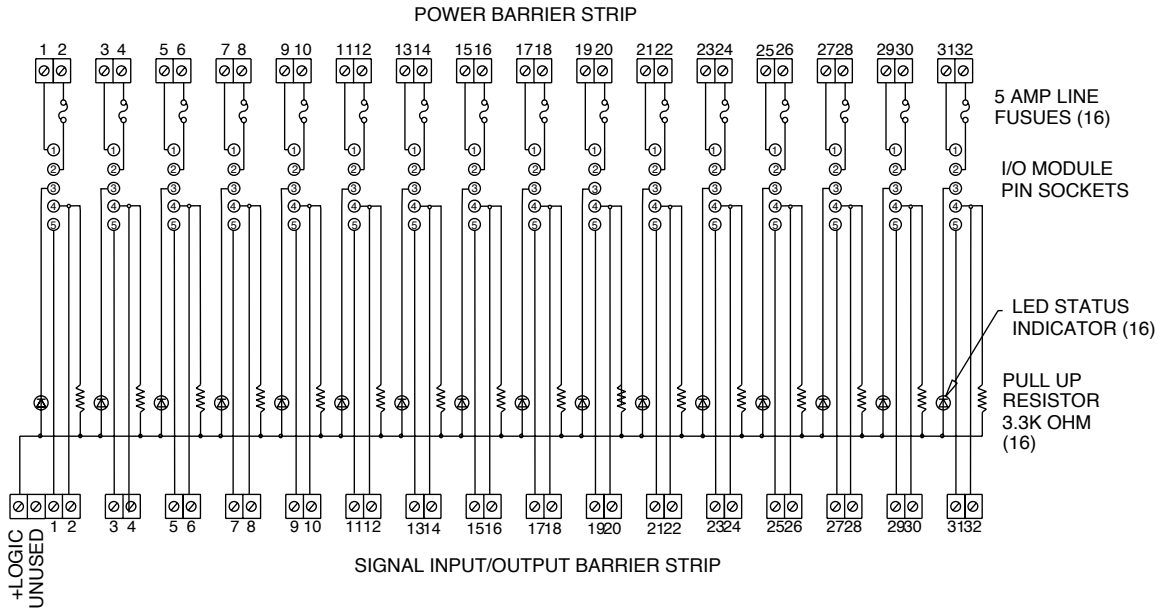
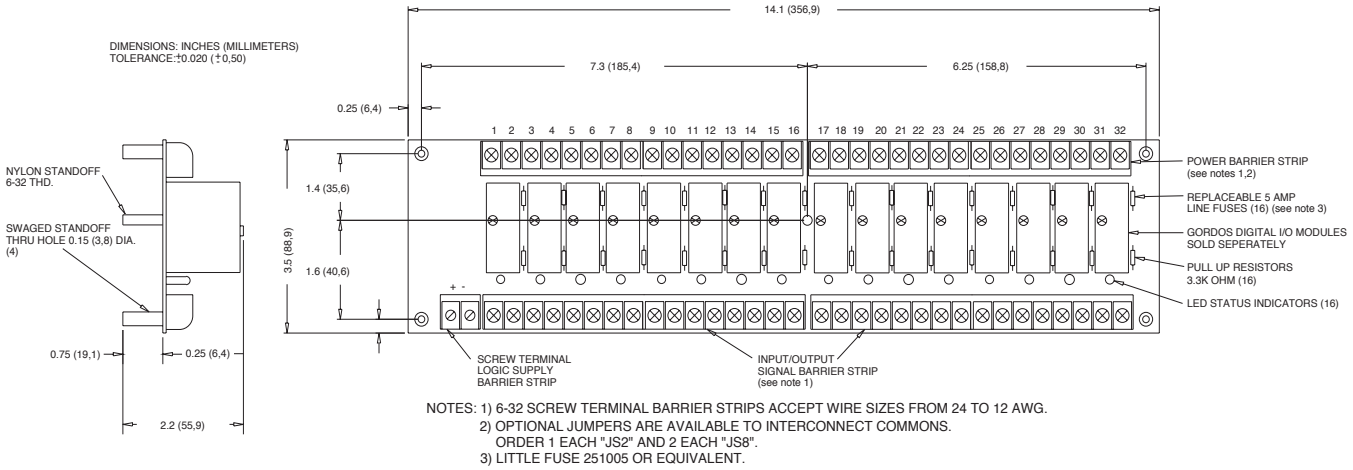

Products and specifications subject to change without notice.

Order/Technical Support – Tel: (800) 677-5311 / FAX: (800) 677-3865 / www.crouzet-usa.com

DIGITAL I/O MODULE MOUNTING BOARDS

FOR 0.6 INCH MODULES (Compatible with "SM" Series Modules)

PB16T

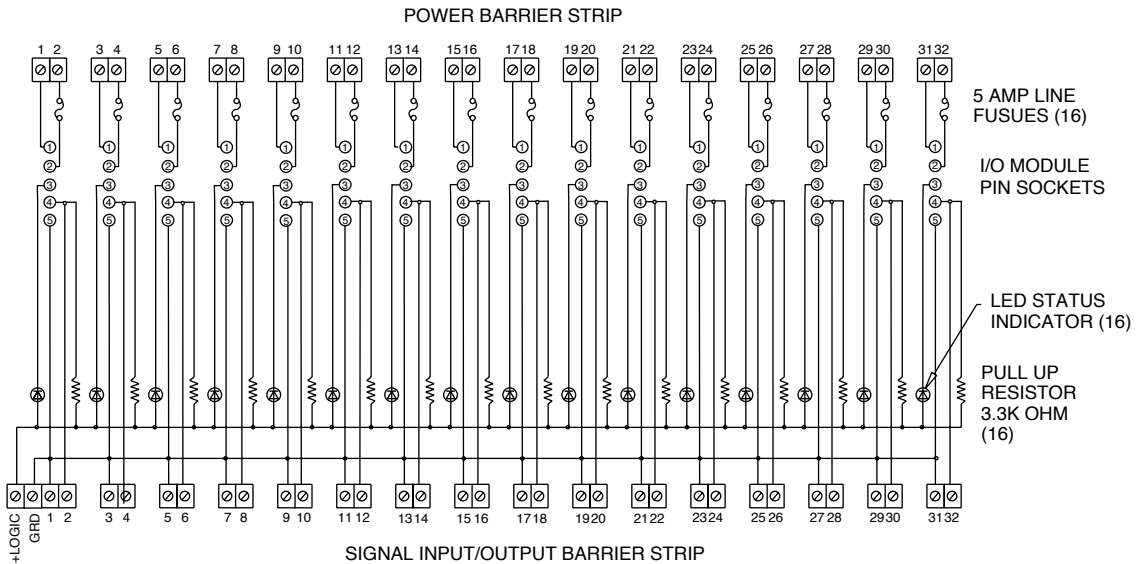
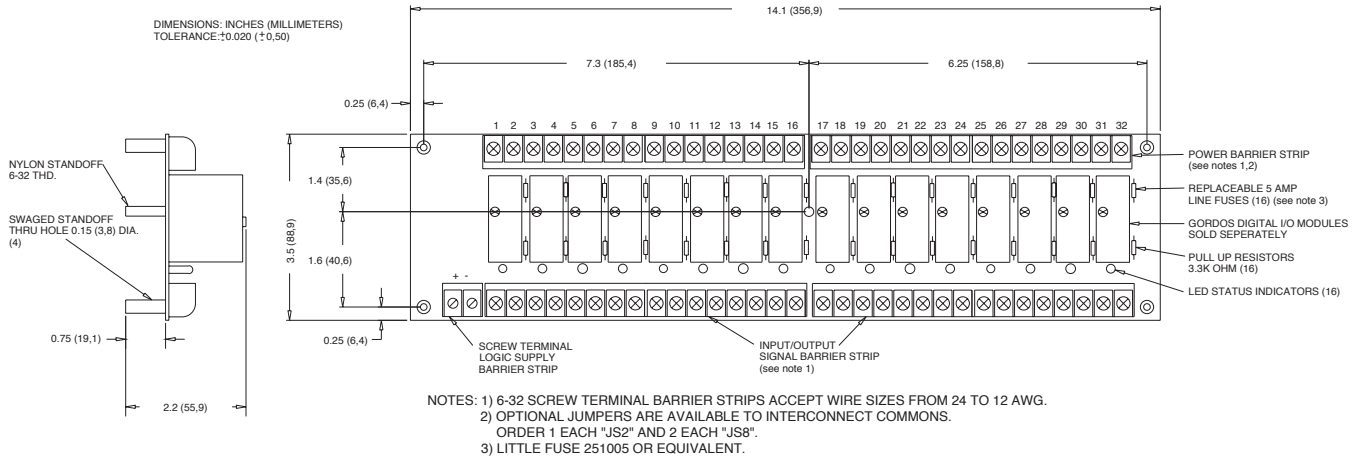

Products and specifications subject to change without notice.

Order/Technical Support – Tel: (800) 677-5311 / FAX: (800) 677-3865 / www.crouzet-usa.com

DIGITAL I/O MODULE MOUNTING BOARDS

FOR 0.6 INCH MODULES (Compatible with "SM" Series Modules)

PB24

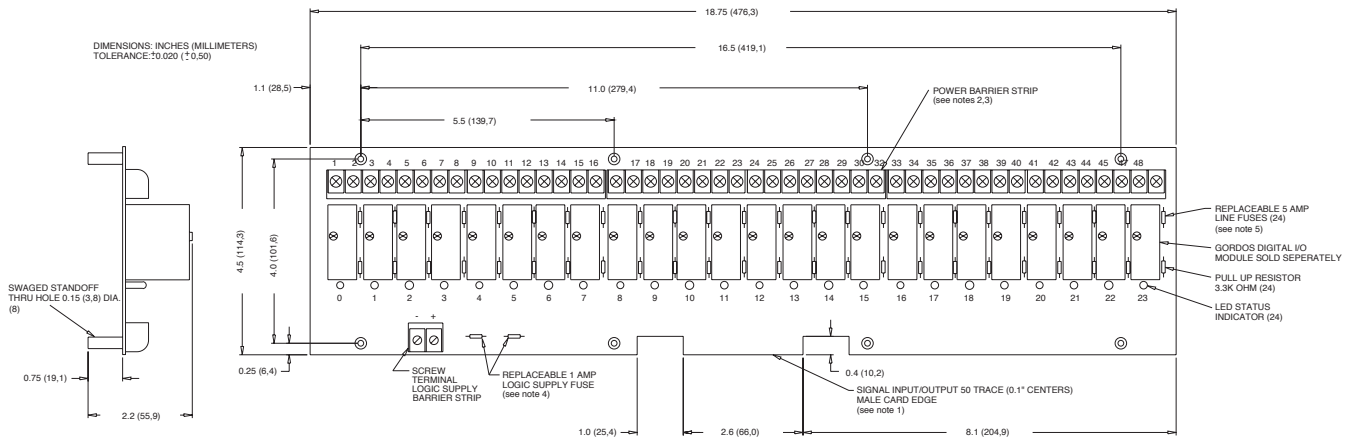

- NOTES: 1) MATING CONNECTOR IS BERG 66317-150 OR EQUIVALENT. SPECIFY SUFFIX 'C' FOR OPTIONAL 65823-093 OR EQUIVALENT MALE PIN CONNECTOR FOR PARALLEL-TO-THE-BOARD CABLE CONNECTION. SPECIFY SUFFIX 'V' FOR OPTIONAL CIRCUIT ASSEMBLY CA-50H-2B-SR OR EQUIVALENT MALE PIN CONNECTOR FOR PERPENDICULAR-TO-THE-BOARD CABLE CONNECTION.
- 2) 6-32 SCREW TERMINAL BARRIER STRIPS ACCEPT WIRE SIZES FROM 24 TO 12 AWG.
- 3) OPTIONAL JUMPERS ARE AVAILABLE TO INTERCONNECT BARRIER STRIP COMMONS. ORDER 2 EACH "JS2" AND 3 EACH "JS8".
- 4) LITTLE FUSE 251001 OR EQUIVALENT.
- 5) LITTLE FUSE 251005 OR EQUIVALENT.

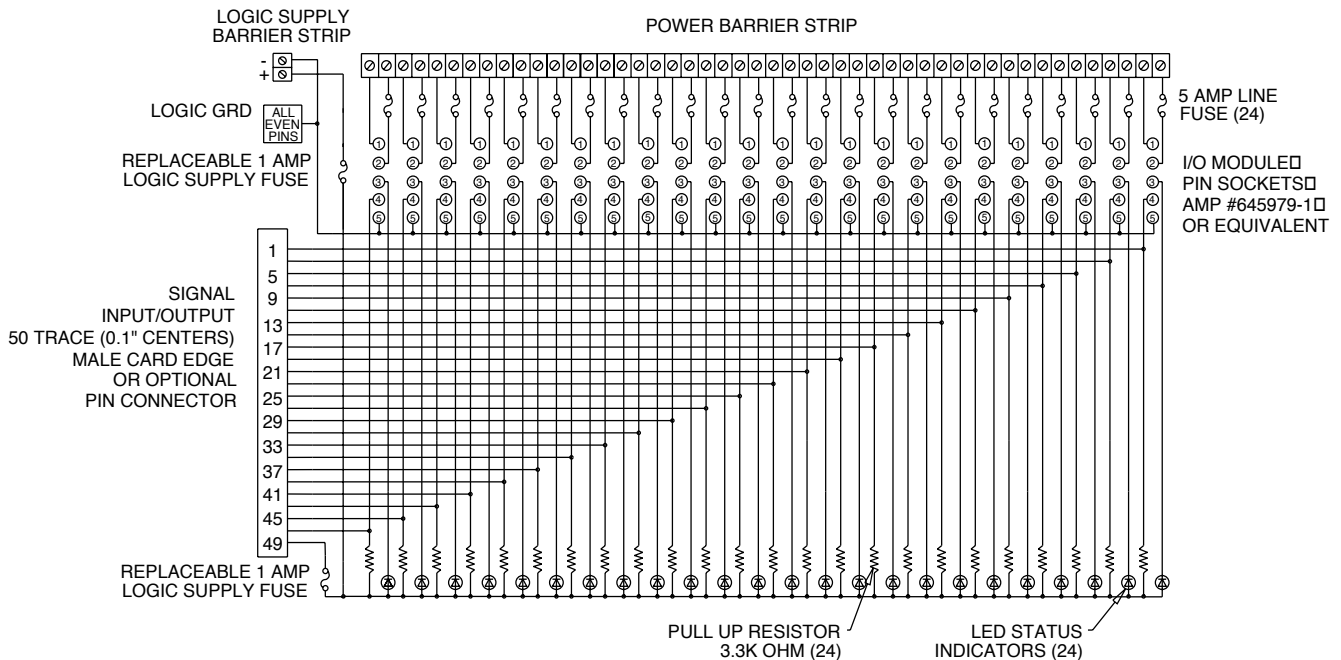

Products and specifications subject to change without notice.

Order/Technical Support – Tel: (800) 677-5311 / FAX: (800) 677-3865 / www.crouzet-usa.com

DIGITAL I/O MODULE MOUNTING BOARDS

FOR "M" SERIES MINIATURE MODULES

PB8M

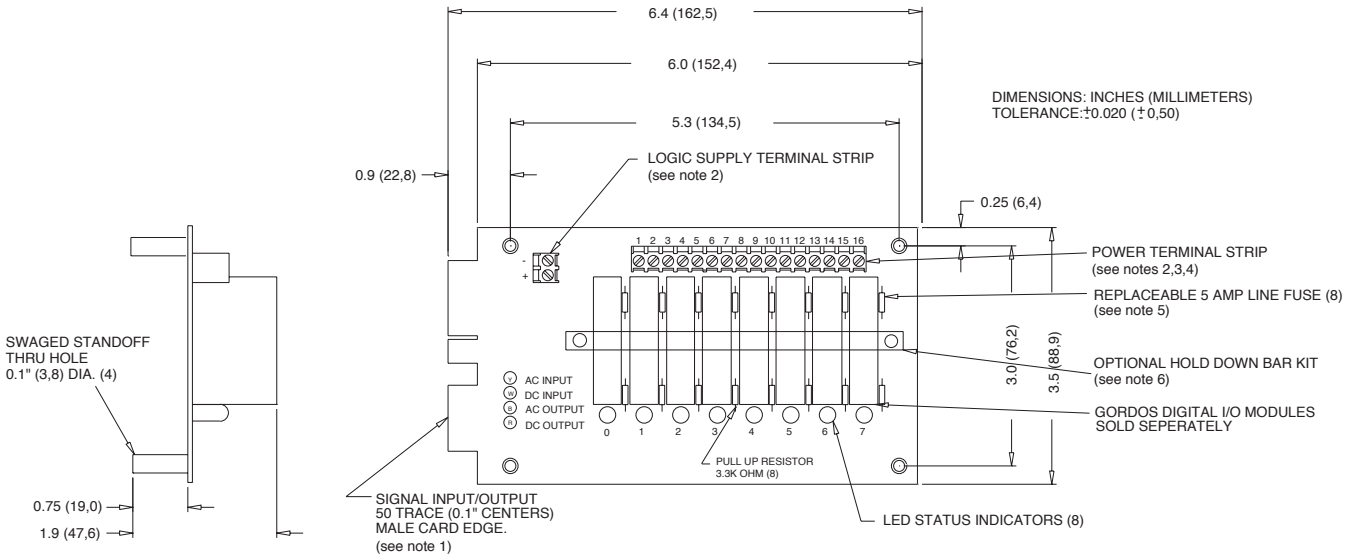

- NOTES: 1) MATING CONNECTOR IS BERG 66317-150 OR EQUIVALENT. SPECIFY SUFFIX 'C' FOR OPTIONAL 65823-093 OR EQUIVALENT MALE PIN CONNECTOR FOR PARALLEL-TO-THE-BOARD CABLE CONNECTION. SPECIFY SUFFIX 'V' FOR OPTIONAL CIRCUIT ASSEMBLY CA-50H-2B-SR OR EQUIVALENT MALE PIN CONNECTOR FOR PERPENDICULAR-TO-THE-BOARD CABLE CONNECTION.
- 2) 4-40 SCREW TERMINAL STRIPS ACCEPT WIRE SIZES FROM 26 TO 14 AWG.
- 3) OPTIONAL JUMPERS ARE AVAILABLE TO INTERCONNECT BARRIER STRIP COMMONS. ORDER 1 EACH "JM8".
- 4) PHOENIX MKD51.5 5.08mm SERIES (OR EQUIVALENT) SCREW TERMINAL BLOCKS STANDARD. SPECIFY SUFFIX "A" FOR BOARD-MOUNTED PHOENIX MSTBVA 1.5/16-G-5.08 (OR EQUIVALENT) MALE CONNECTOR. SPECIFY SUFFIX "B" FOR BOARD-MOUNTED PHOENIX MSTBVA 1.5/16-G-5.08 (OR EQUIVALENT) MALE CONNECTOR AND MATING PHOENIX MSTBVA 1.5/16-ST-5.08 (OR EQUIVALENT) FEMALE, SCREW-TERMINAL PLUG-IN CONNECTOR.
- 5) LITTLE FUSE 251005 OR EQUIVALENT.
- 6) TWO HOLD-DOWN BAR KITS ARE AVAILABLE SEPARATELY. MODEL NO. 11.06.414 EMPLOYS A PLAIN ALUMINUM CHANNEL WHILE MODEL NO. 11.06.293 PROVIDES POCKETS IN THE CHANNEL FOR INDIVIDUAL MODULES.

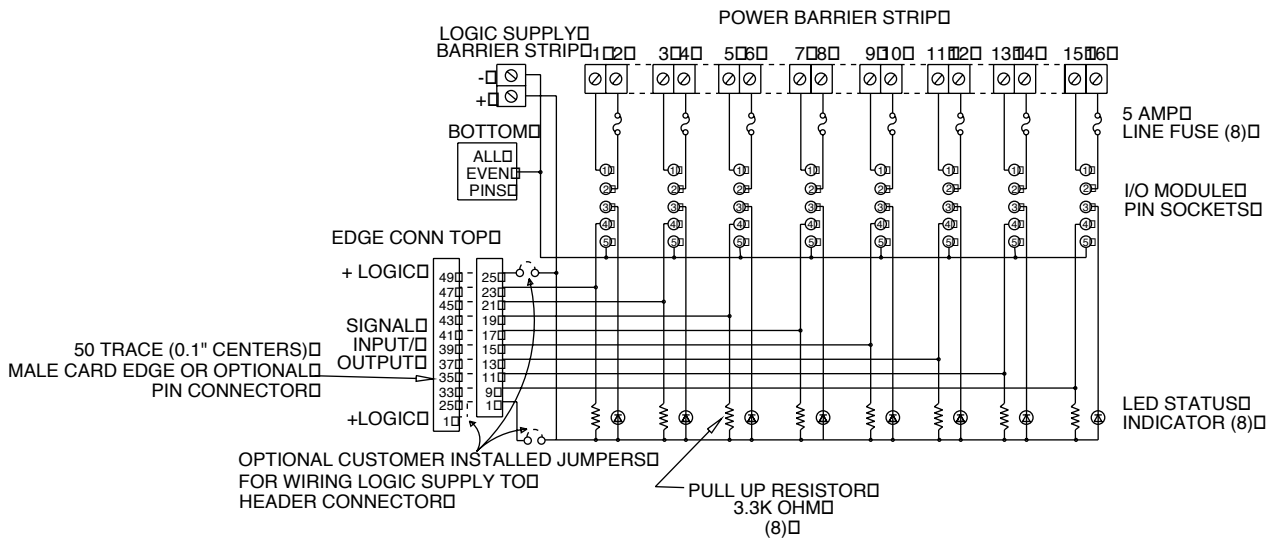

Products and specifications subject to change without notice.

Order/Technical Support – Tel: (800) 677-5311 / FAX: (800) 677-3865 / www.crouzet-usa.com

DIGITAL I/O MODULE MOUNTING BOARDS

FOR "M" SERIES MINIATURE MODULES

PB16M

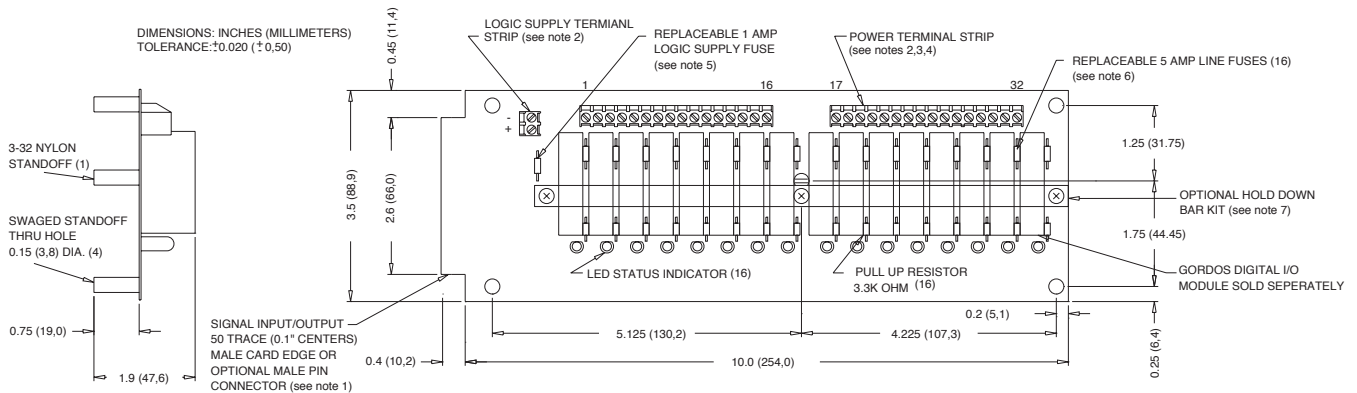

- NOTES: 1) MATING CONNECTOR IS BERG 66317-150 OR EQUIVALENT. SPECIFY SUFFIX 'C' FOR OPTIONAL 65823-093 OR EQUIVALENT MALE PIN CONNECTOR FOR PARALLEL-TO-THE-BOARD CABLE CONNECTION. SPECIFY SUFFIX 'V' FOR OPTIONAL CIRCUIT ASSEMBLY CA-50H-2B-SR OR EQUIVALENT MALE PIN CONNECTOR FOR PERPENDICULAR-TO-THE-BOARD CABLE CONNECTION.
- 2) 4-40 SCREW TERMINAL STRIPS ACCEPT WIRE SIZES FROM 26 TO 14 AWG.
- 3) OPTIONAL JUMPERS ARE AVAILABLE TO INTERCONNECT BARRIER STRIP ORDER 1 EACH "JM2" AND 2 EACH "JM6".
- 4) PHOENIX MKDS1.5 5.08mm SERIES (OR EQUIVALENT) SCREW TERMINAL BLOCKS STANDARD. SPECIFY SUFFIX "A" FOR BOARD-MOUNTED PHOENIX MSTBVA 1.5/16-G-5.08 (OR EQUIVALENT) MALE CONNECTOR. SPECIFY SUFFIX "B" FOR BOARD-MOUNTED PHOENIX MSTBVA 1.5/16-G-5.08 (OR EQUIVALENT) MALE CONNECTOR AND MATING PHOENIX MSTBVA 1.5/16-ST-5.08 (OR EQUIVALENT) FEMALE. SCREW-TERMINAL PLUG-IN CONNECTOR.
- 5) LITTLE FUSE 251001 OR EQUIVALENT.
- 6) LITTLE FUSE 251005 OR EQUIVALENT.
- 7) TWO HOLD-DOWN BAR KITS ARE AVAILABLE SEPARATELY. MODEL NO. 11.06.415 EMPLOYS A PLAIN ALUMINUM CHANNEL WHILE MODEL NO. 11.06.278 PROVIDES POCKETS IN THE CHANNEL FOR INDIVIDUAL MODULES.

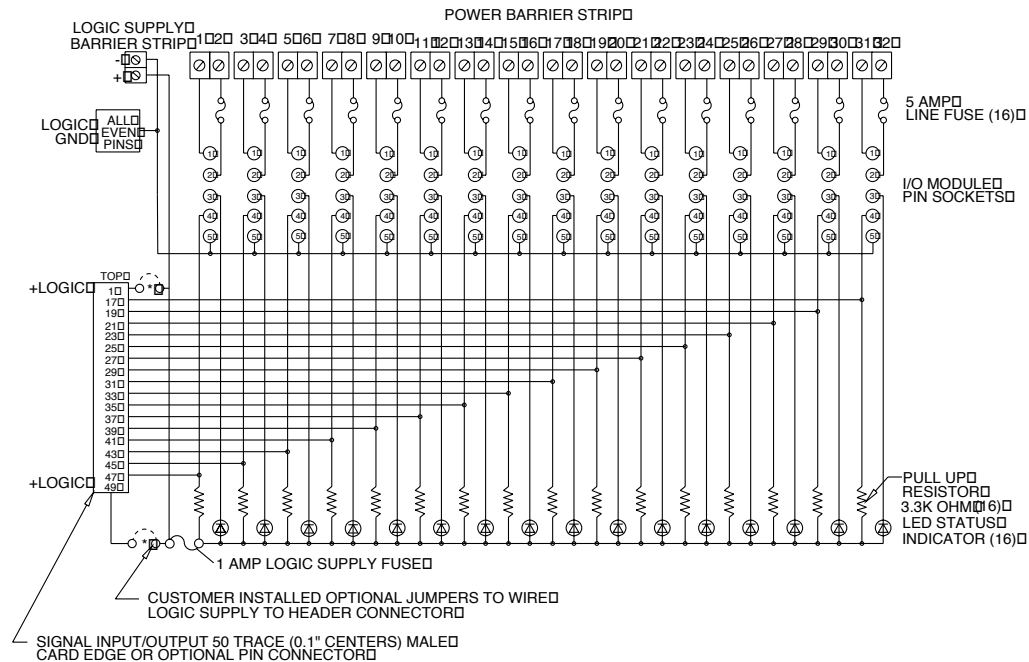

Products and specifications subject to change without notice.

Order/Technical Support – Tel: (800) 677-5311 / FAX: (800) 677-3865 / www.crouzet-usa.com

DIGITAL I/O MODULE MOUNTING BOARDS

FOR "M" SERIES MINIATURE MODULES

PB24M

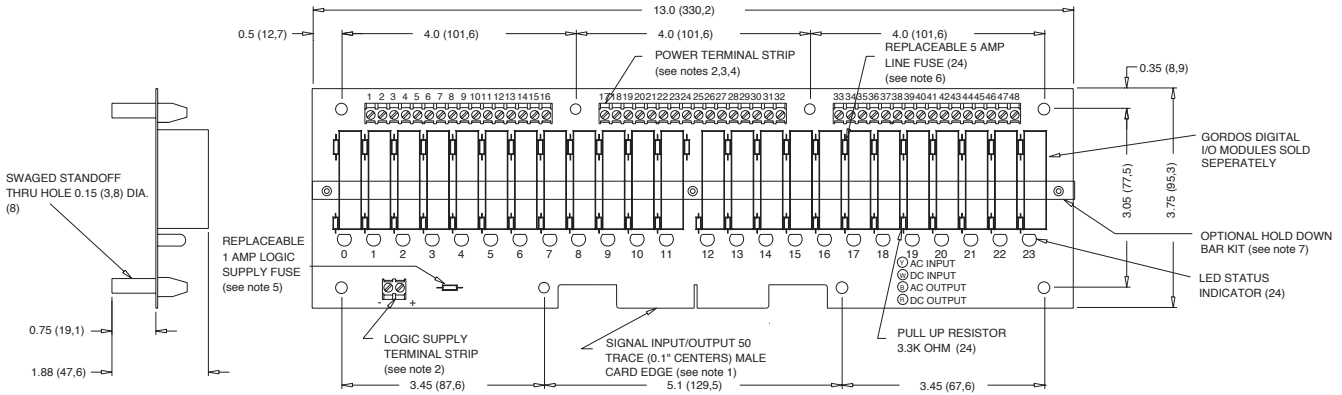

- NOTES: 1) MATING CONNECTOR IS BERG 66317-150 OR EQUIVALENT. SPECIFY SUFFIX 'C' FOR OPTIONAL 65623-093 OR EQUIVALENT MALE PIN CONNECTOR FOR PARALLEL-TO-THE-BOARD CONNECTION. SPECIFY SUFFIX 'V' FOR OPTIONAL CIRCUIT ASSEMBLY CA-50H-2B-SR OR EQUIVALENT MALE PIN CONNECTOR FOR PERPENDICULAR-TO-THE-BOARD CONNECTION.
- 2) 4-40 TERMINAL STRIPS ACCEPT WIRE SIZES FROM 26 TO 14 AWG.
- 3) OPTIONAL JUMPERS ARE AVAILABLE TO INTERCONNECT BARRIER STRIP ORDER 3 EACH "UM".
- 4) PHOENIX MKD51.5 5.08mm SERIES (OR EQUIVALENT) SCREW TERMINAL BLOCKS STANDARD. SPECIFY SUFFIX "A" FOR BOARD-MOUNTED PHOENIX MSTBVA 1.5/16-G-5.08 (OR EQUIVALENT) MALE CONNECTOR. SPECIFY SUFFIX "B" FOR BOARD-MOUNTED PHOENIX MSTBVA 1.5/16-G-5.08 (OR EQUIVALENT) MALE CONNECTOR AND MATING PHOENIX MSTBVA 1.5/16-ST-5.08 (OR EQUIVALENT) FEMALE. SCREW-TERMINAL PLUG-IN CONNECTOR.
- 5) LITTLE FUSE 251001 OR EQUIVALENT.
- 6) LITTLE FUSE 251005 OR EQUIVALENT.
- 7) TWO HOLD-DOWN BAR KITS ARE AVAILABLE SEPARATELY. MODEL NO. 11.06.413 EMPLOY A PLAIN ALUMINUM CHANNEL WHILE MODEL NO. 11.06.288 PROVIDES POCKETS IN THE CHANNEL FOR INDIVIDUAL MODULES.

DIMENSIONS: INCHES (MILLIMETERS)
TOLERANCE: ±0.020 (±0.50)

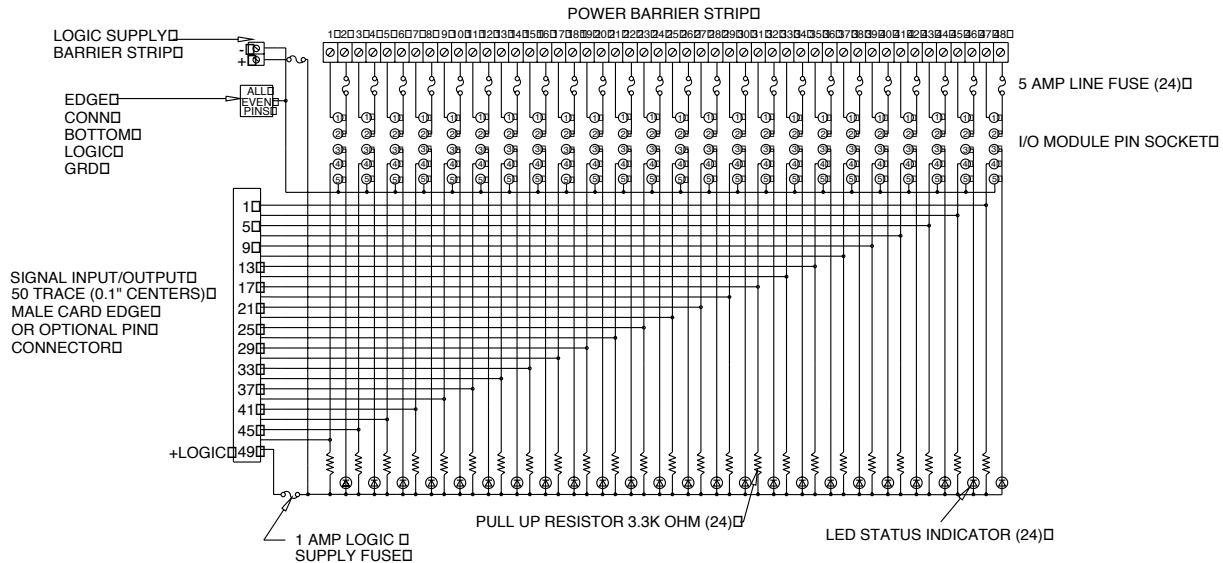

Products and specifications subject to change without notice.

Order/Technical Support – Tel: (800) 677-5311 / FAX: (800) 677-3865 / www.crouzet-usa.com

DIGITAL I/O MODULE MOUNTING BOARDS

FOR "M" SERIES MINIATURE MODULES

PB24MD

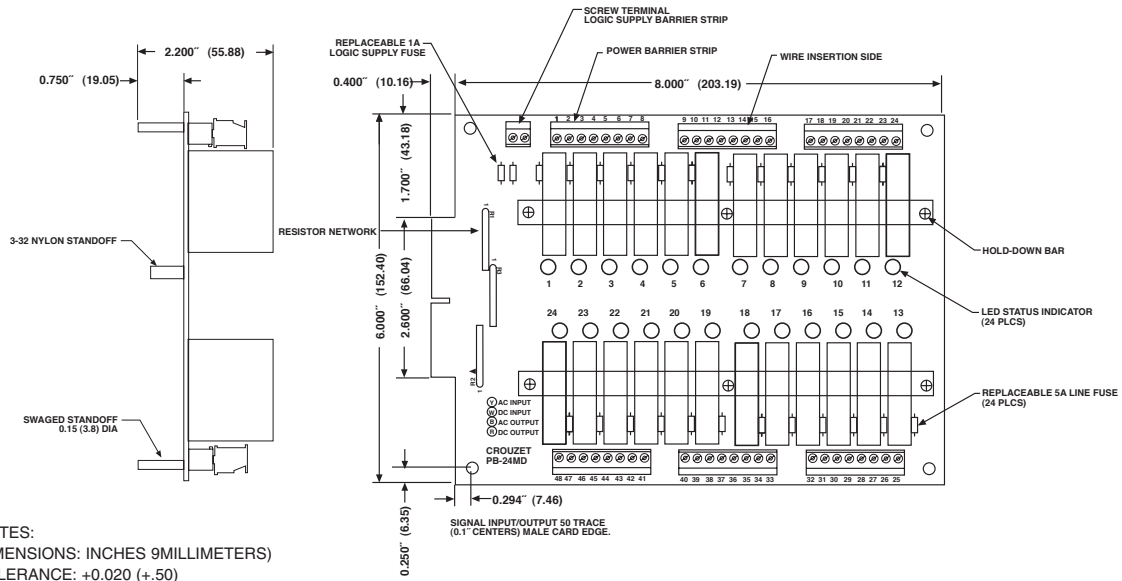

NOTES:
 DIMENSIONS: INCHES 9MILLIMETERS)
 TOLERANCE: +0.020 (+.50)

- NOTES: 1) MATING CONNECTOR IS BERG66317-150 OR EQUIVALENT. SPECIFY SUFFIX 'C' FOR OPTIONAL 65823-093 OR EQUIVALENT MALE PIN CONNECTOR FOR PARALLEL-TO-THE-BOARD CABLE CONNECTION. SPECIFY SUFFIX 'V' FOR OPTIONAL CIRCUIT ASSEMBLY CA-50H-2B-SR OR EQUIVALENT MALE PIN CONNECTOR FOR PERPENDICULAR-TO-THE-BOARD CABLE CONNECTION.
 2) 4-40 TERMINAL STRIPS ACCEPT WIRE SIZES FROM 26 TO 14 AWG.
 3) OPTIONAL JUMPERS ARE AVAILABLE TO INTERCONNECT BARRIER STRIP ORDER "JM8"
 4) PHOENIX MKD51.5 5.08mm SERIES (OR EQUIVALENT) SCREW TERMINAL BLOCKS STANDARD. SPECIFY SUFFIX "A" FOR BOARD-MOUNTED PHOENIX MSTBVA 1.5/16-G-5.08 (OR EQUIVALENT) MALE CONNECTOR. SPECIFY SUFFIX "B" FOR BOARD-MOUNTED PHOENIX MSTBVA 1.5/16-G-5.08 (OR EQUIVALENT) MALE CONNECTOR AND MATING PHOENIX MSTBVA 1.5/16-ST-5.08 (OR EQUIVALENT) FEMALE. SCREW-TERMINAL PLUG-IN CONNECTOR.
 5) LITTLE FUSE 251001 OR EQUIVALENT.
 6) LITTLE FUSE 251005 OR EQUIVALENT.

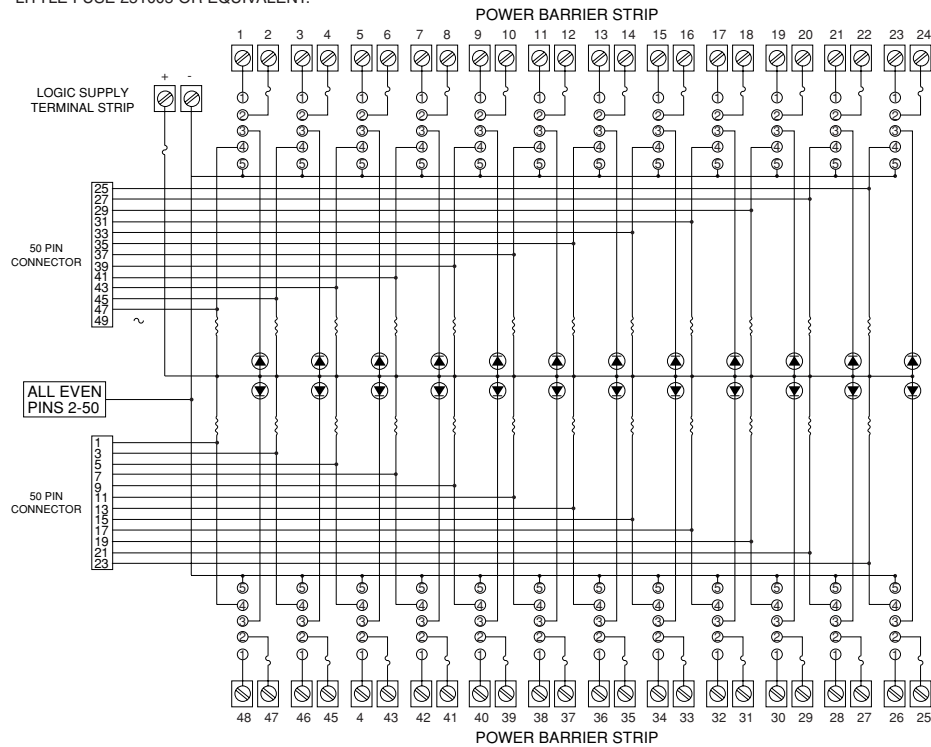

Products and specifications subject to change without notice.

Order/Technical Support – Tel: (800) 677-5311 / FAX: (800) 677-3865 / www.crouzet-usa.com

DIGITAL I/O MODULE MOUNTING BOARDS

FOR "M" SERIES MINIATURE MODULES

PB32M

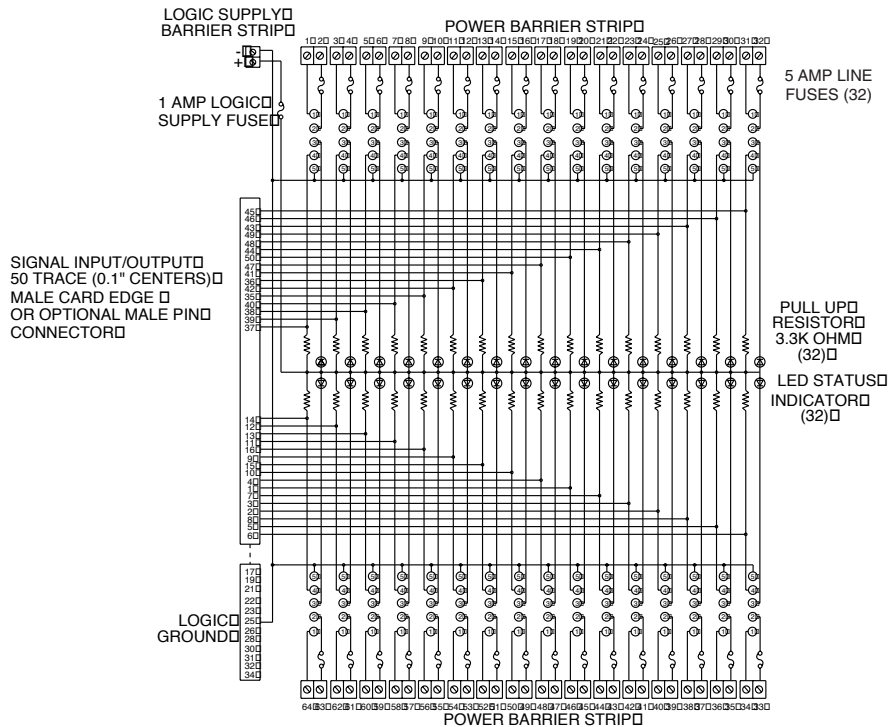
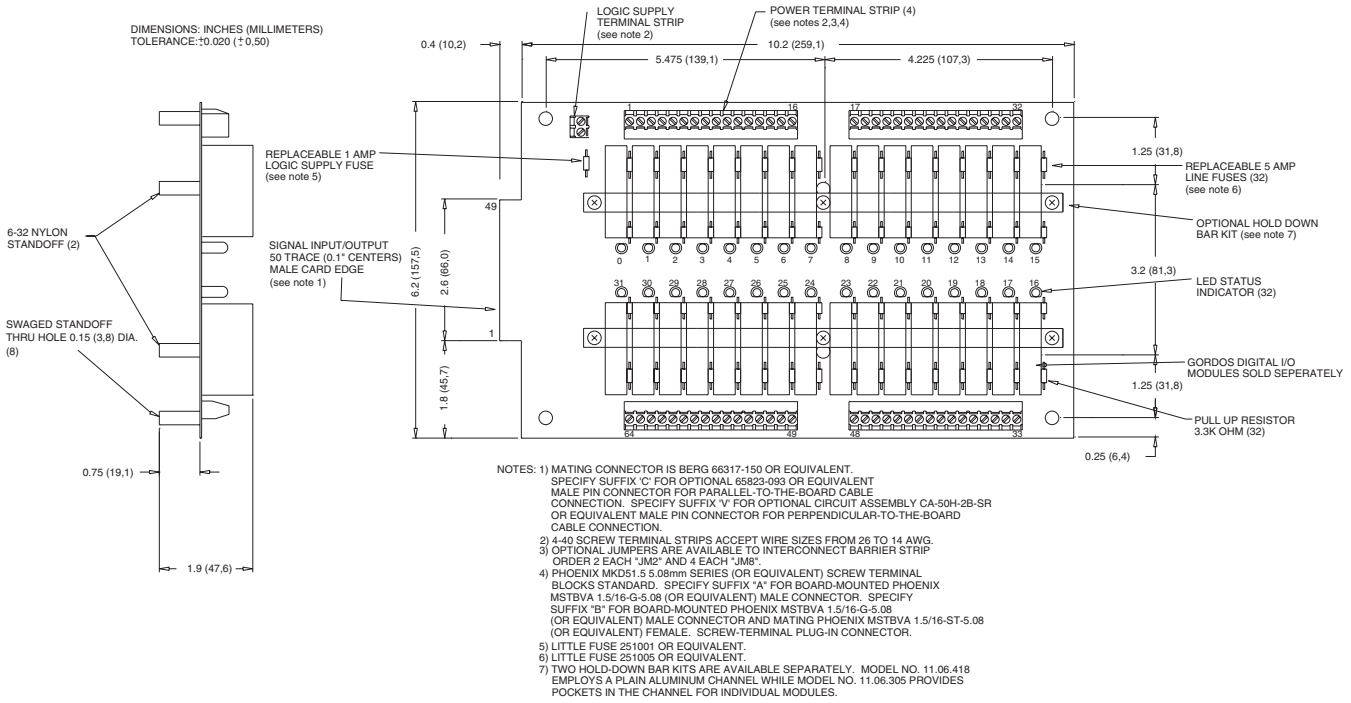

Products and specifications subject to change without notice.

Order/Technical Support – Tel: (800) 677-5311 / FAX: (800) 677-3865 / www.crouzet-usa.com

DIGITAL I/O MODULE MOUNTING BOARDS

FOR QUAD-PACK MODULES

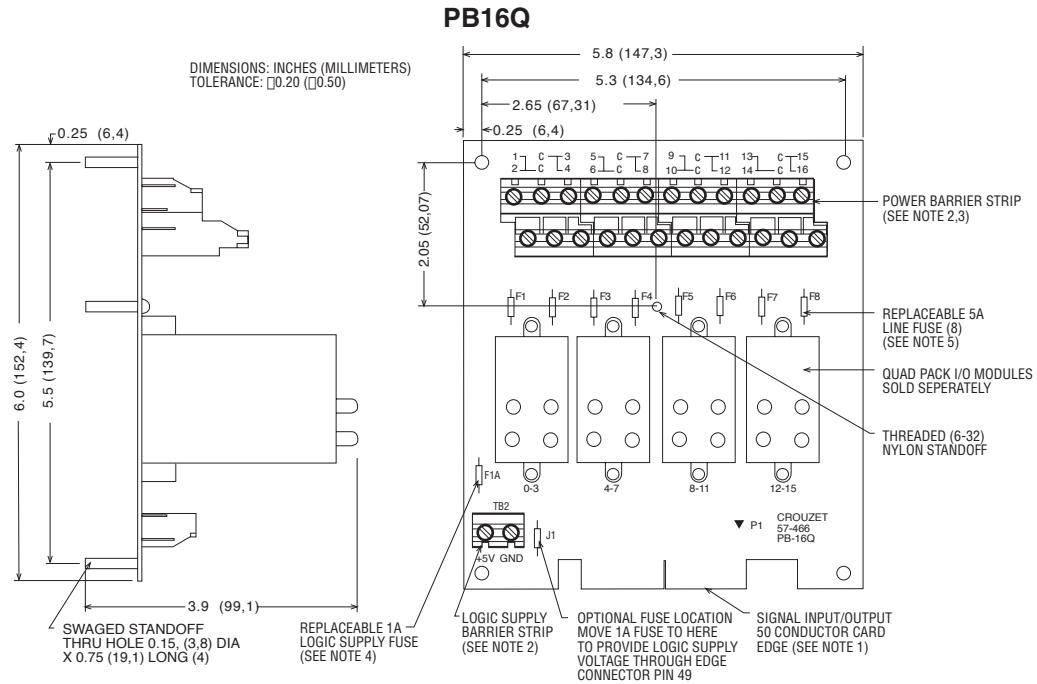

NOTES:

- 1) MATING CONNECTOR IS BERG 66317-150 OR EQUIVALENT. SPECIFY SUFFIX "C" FOR OPTIONAL BERG 65823-093 (OR EQUIVALENT) MALE PIN CONNECTOR FOR PARALLEL-TO-THE BOARD CABLE CONNECTION. SPECIFY SUFFIX "V" FOR OPTIONAL CIRCUIT ASSEMBLY CA-50H-2B-SR (OR EQUIVALENT) MALE PIN CONNECTOR FOR PERPENDICULAR-TO-THE-BOARD CABLE CONNECTION.
- 2) BARRIER STRIPS ACCEPT WIRE SIZES FROM 24 TO 12 AWG.
- 3) OPTIONAL JUMPERS AVAILABLE TO INTERCONNECT BARRIER STRIP COMMONS. ORDER 2 EACH JUMPER "JQ4".
- 4) LITTLE FUSE 251001 OR EQUIVALENT.
- 5) LITTLE FUSE 251005 OR EQUIVALENT.

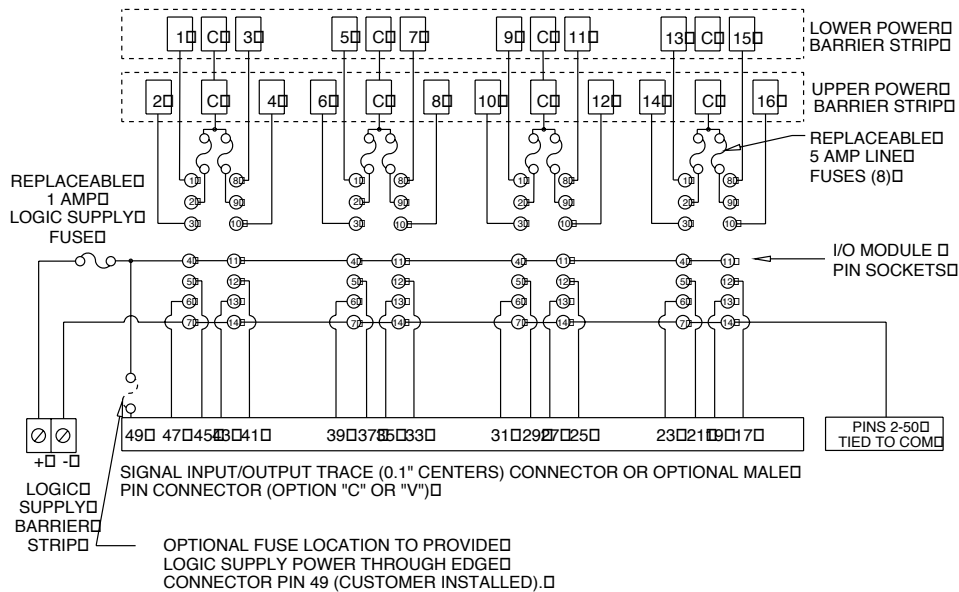

Products and specifications subject to change without notice.

Order/Technical Support – Tel: (800) 677-5311 / FAX: (800) 677-3865 / www.crouzet-usa.com

DIGITAL I/O MODULE MOUNTING BOARDS

FOR QUAD-PACK MODULES

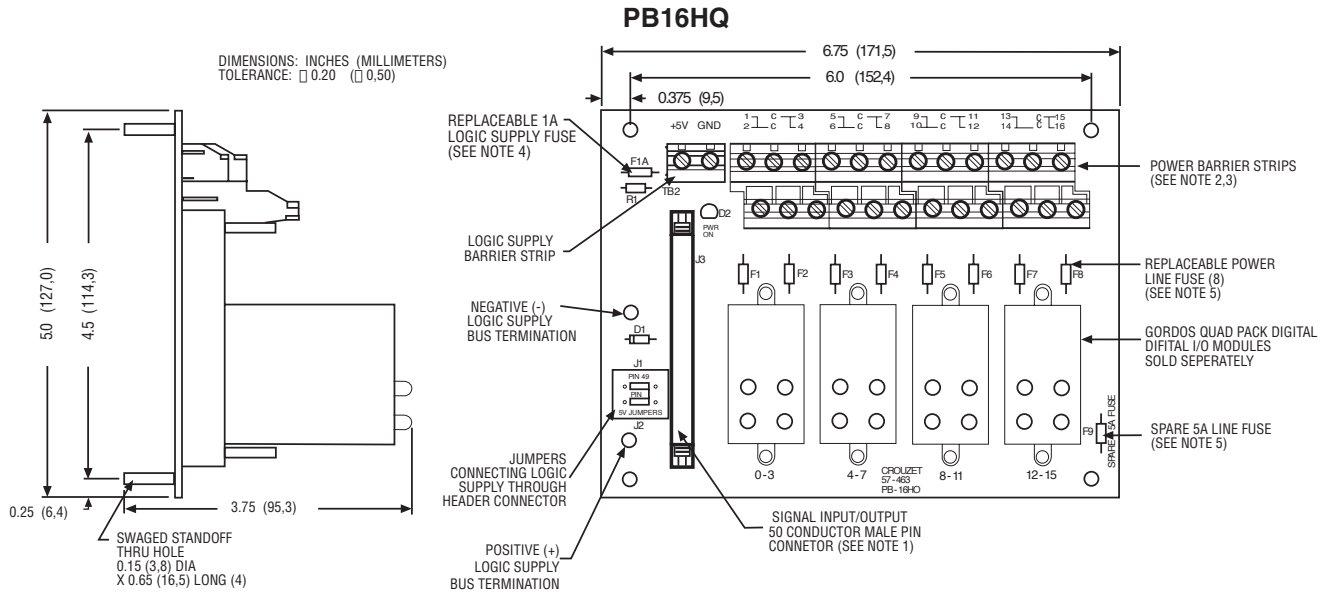

NOTES:

- 1) CONNECTOR IS BERG 65863-145 OR EQUIVALENT.
- 2) 6-32 SCREW TERMINAL BARRIER STRIPS ACCEPT WIRE SIZES FROM 24 TO 12 AWG.
- 3) OPTIONAL JUMPERS AVAILABLE TO INTERCONNECT BARRIER STRIP COMMONS. ORDER 2 EACH JUMPER "JQ4".
- 4) LITTLE FUSE 251001 OR EQUIVALENT.
- 5) LITTLE FUSE 251005 OR EQUIVALENT.

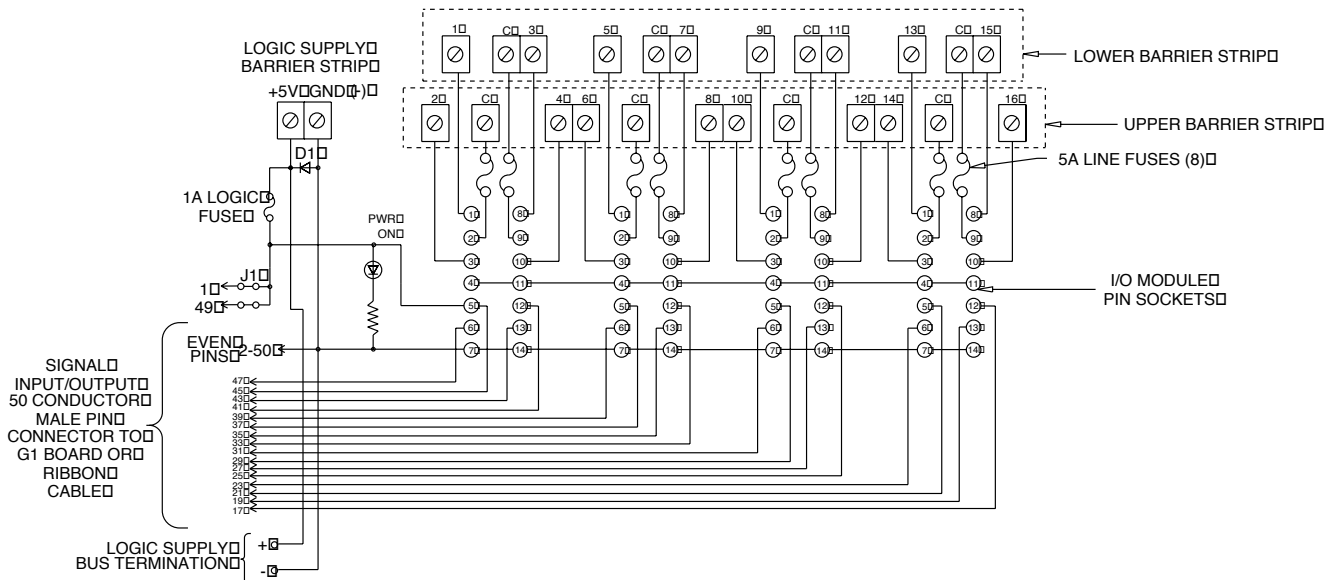

Products and specifications subject to change without notice.

Order/Technical Support – Tel: (800) 677-5311 / FAX: (800) 677-3865 / www.crouzet-usa.com

DIGITAL I/O MODULE MOUNTING BOARDS

FOR QUAD-PACK MODULES

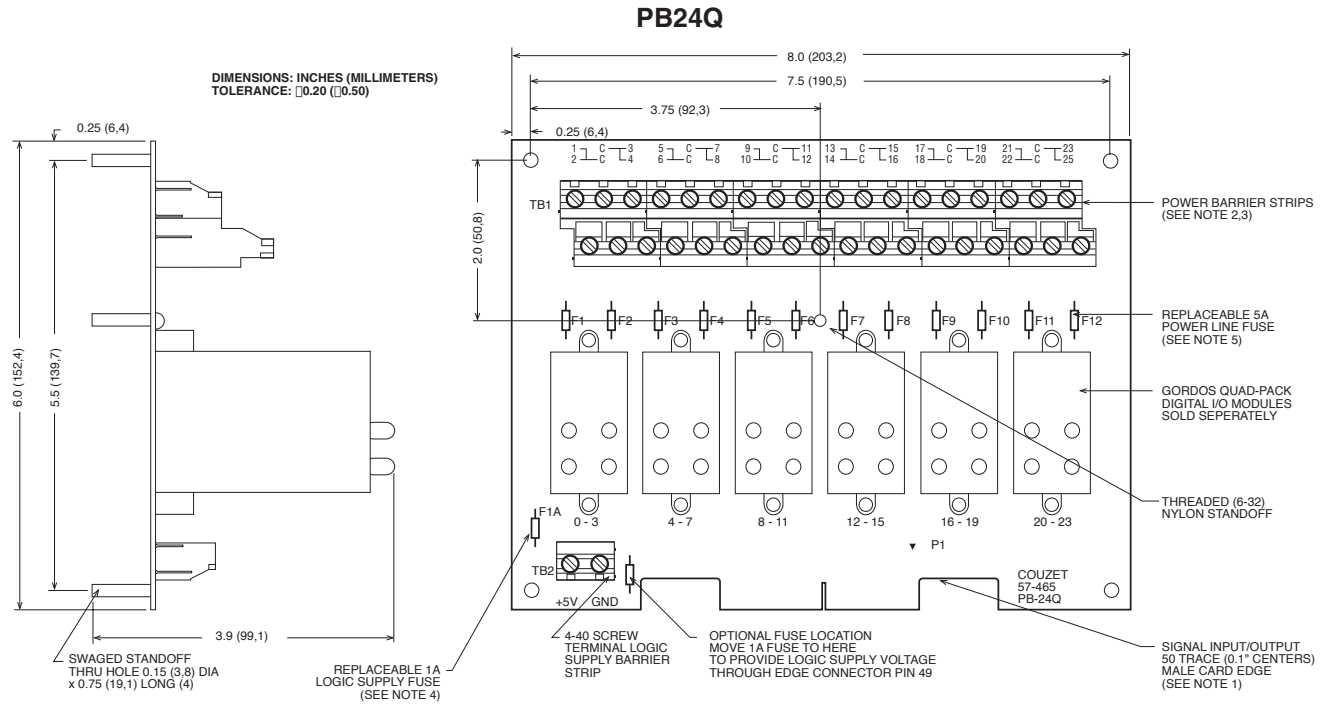

NOTES:

- 1) MATING CONNECTOR IS BERG 66317-150 OR EQUIVALENT. SPECIFY SUFFIX "C" FOR OPTIONAL BERG 65823-093 (OR EQUIVALENT) MALE PIN CONNECTOR FOR PARALLEL-TO-THE BOARD CABLE CONNECTION. SPECIFY SUFFIX "V" FOR OPTIONAL BERG 65863-145 (OR EQUIVALENT) MALE PIN CONNECTOR FOR PERPENDICULAR-TO-THE-BOARD CABLE CONNECTION.
- 2) 6-32 SCREW TERMINAL BARRIER STRIPS ACCEPT WIRE SIZES FORM 24 TO 12 AWG.
- 3) OPTIONAL JUMPERS AVAILABLE TO INTERCONNECT BARRIER STRIP COMMONS. ORDER 2 EACH JUMPER "J04".
- 4) LITTLE FUSE 251001 OR EQUIVALENT.
- 5) LITTLE FUSE 251005 OR EQUIVALENT.

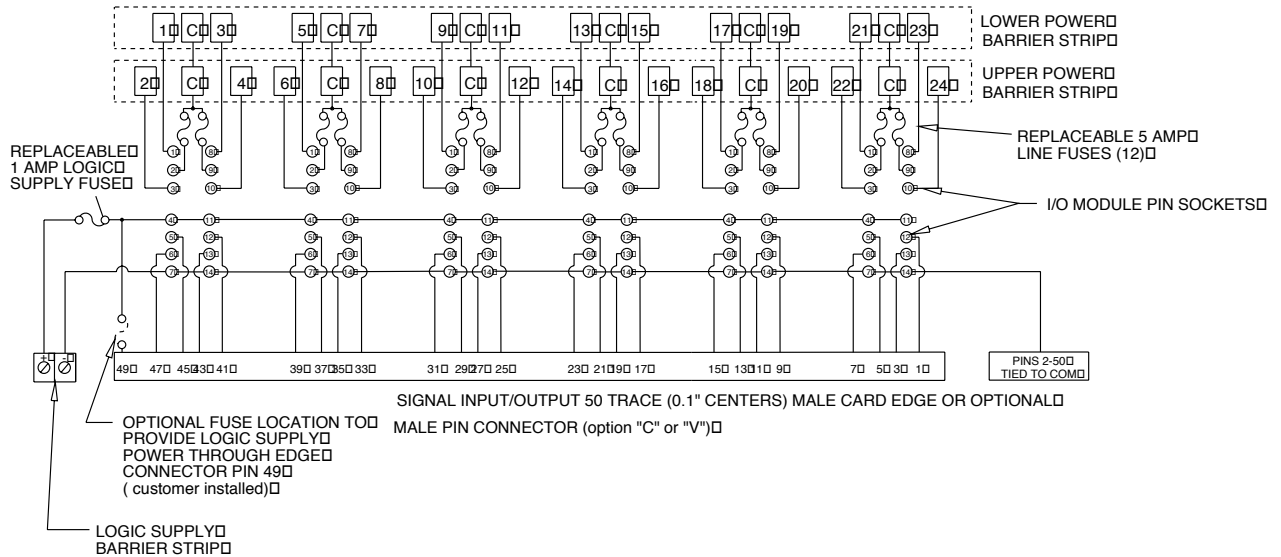

Products and specifications subject to change without notice.

Order/Technical Support – Tel: (800) 677-5311 / FAX: (800) 677-3865 / www.crouzet-usa.com

DIGITAL I/O MODULE MOUNTING BOARDS

FOR QUAD-PACK MODULES

PB24HQ

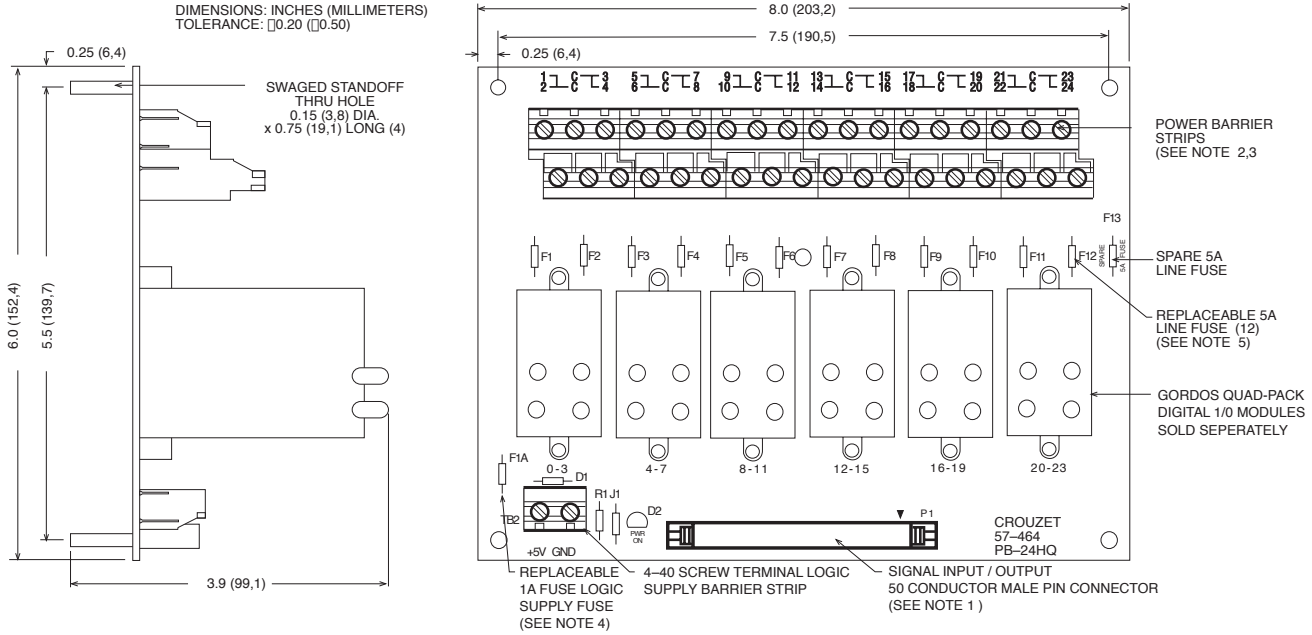

- NOTES: 1) CONNECTOR IS CIRCUIT ASSEMBLY CA-50H-2B-SR OR EQUIVALENT.
2) 6-32 SCREW TERMINAL BARRIER STRIPS ACCEPT WIRE SIZES FROM 24 TO 12 AWG.
3) OPTIONAL JUMPERS AVAILABLE TO INTERCONNECT BARRIER STRIP COMMONS.
ORDER 2 EACH JUMPERS "JQ2" AND 4 EACH JUMPERS "JQ4".
JQ4 REQUIRES CUSTOMER MODIFICATIONS TO USE WITH PB24HQ.
4) LITTLE FUSE 251001 OR EQUIVALENT.
5) LITTLE FUSE 251005 OR EQUIVALENT.

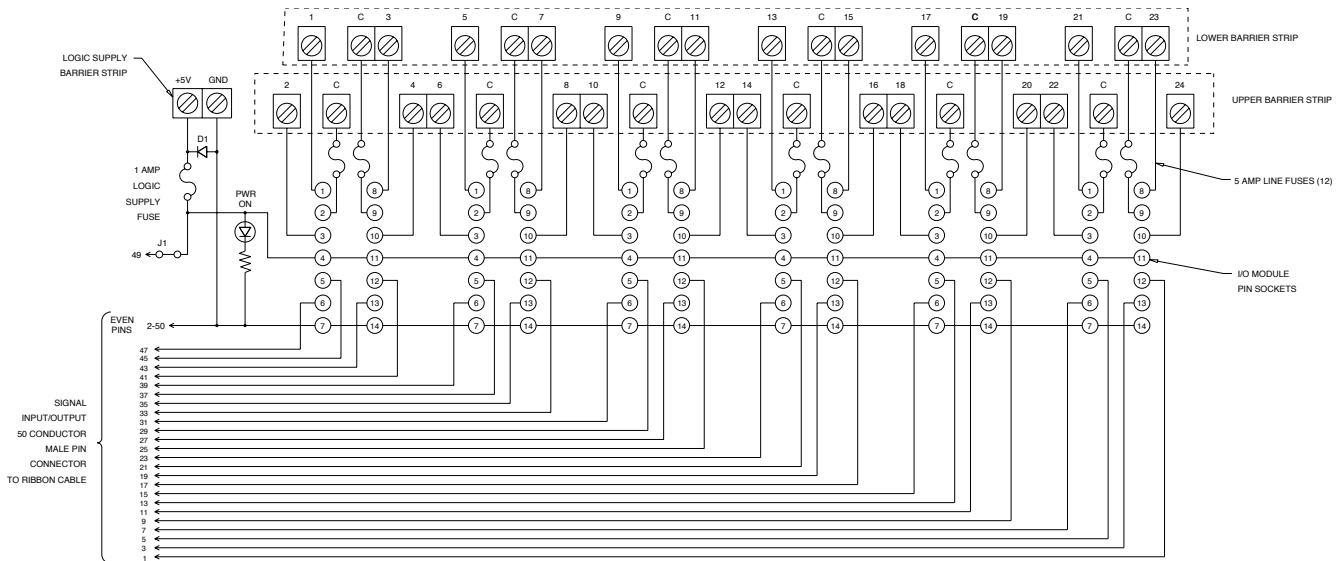

Products and specifications subject to change without notice.

Order/Technical Support – Tel: (800) 677-5311 / FAX: (800) 677-3865 / www.crouzet-usa.com

DIGITAL I/O MODULE MOUNTING BOARDS

FOR QUAD-PACK MODULES

1

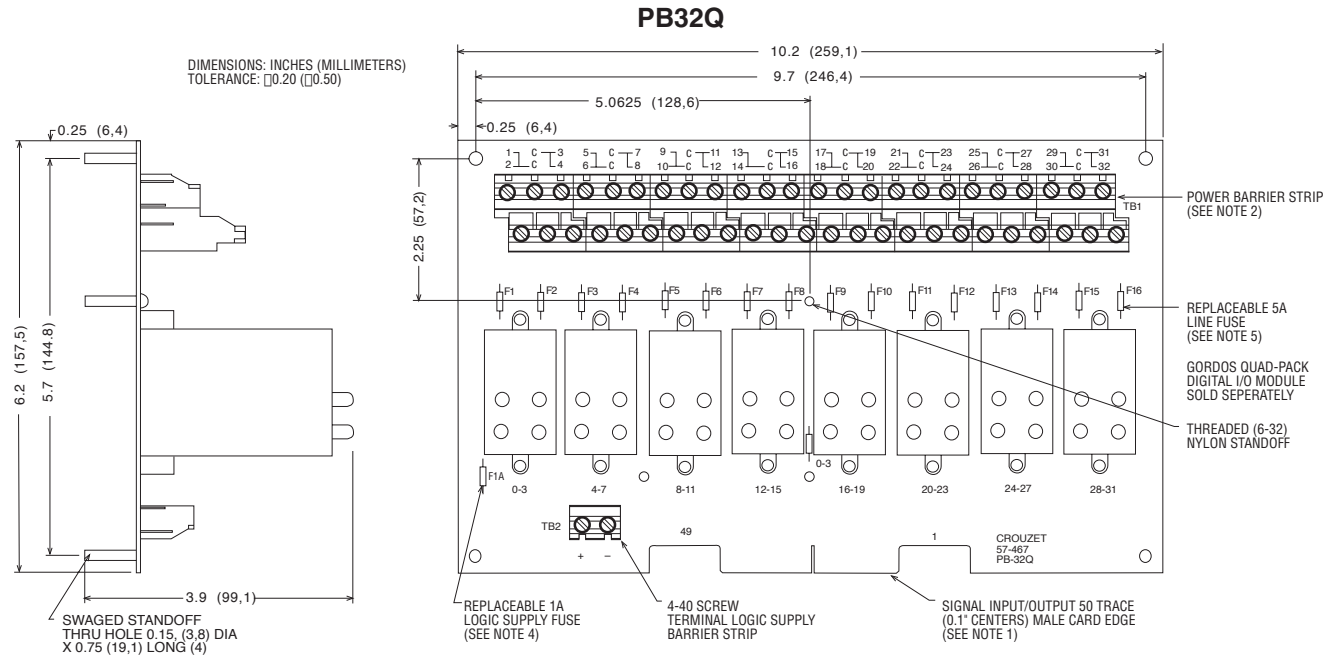

- NOTES:**
- 1) MATING CONNECTOR IS BERG 66317-150 OR EQUIVALENT. SPECIFY SUFFIX "C" FOR OPTIONAL BERG 65823-093 (OR EQUIVALENT) MALE PIN CONNECTOR FOR PARALLEL-TO-THE BOARD CABLE CONNECTION. SPECIFY SUFFIX "V" FOR OPTIONAL CIRCUIT ASSEMBLY CA-50H-2B-SR (OR EQUIVALENT) MALE PIN CONNECTOR FOR PERPENDICULAR-TO-THE-BOARD CABLE CONNECTION.
 - 2) 6-32 SCREW TERMINAL BARRIER STRIPS ACCEPT WIRE SIZES FROM 24 TO 12 AWG.
 - 3) OPTIONAL JUMPERS AVAILABLE TO INTERCONNECT BARRIER STRIP COMMONS. ORDER 2 EACH JUMPERS "JQ2" AND 2 EACH JUMPERS "JQ4".
 - 4) LITTLE FUSE 251001 OR EQUIVALENT.
 - 5) LITTLE FUSE 251005 OR EQUIVALENT.

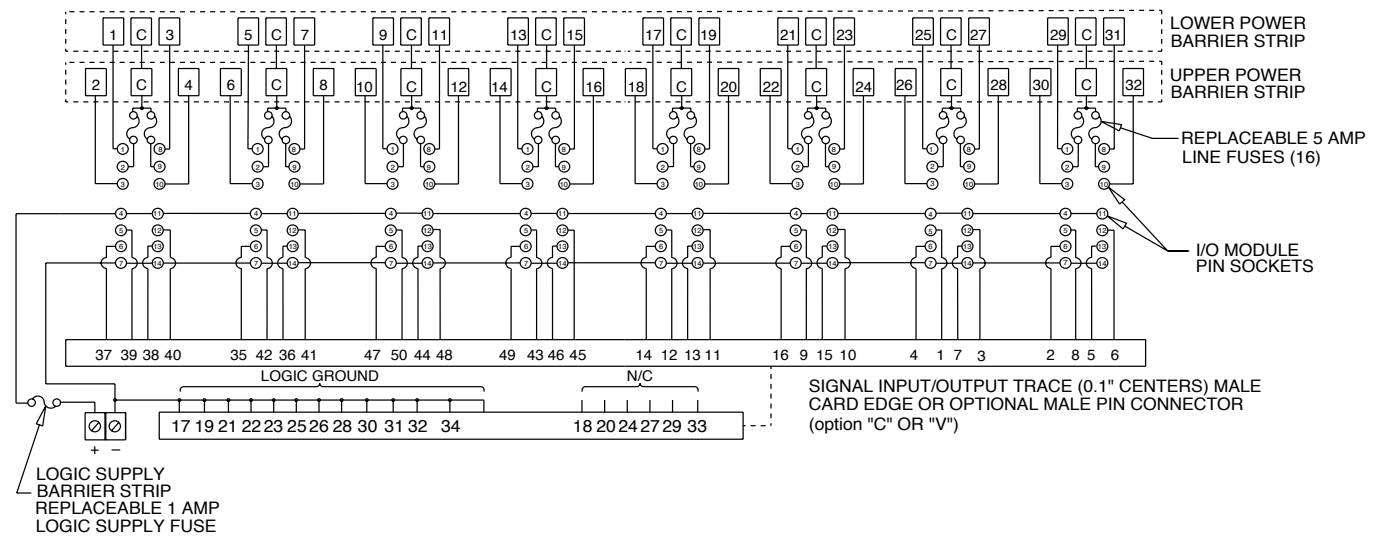

Products and specifications subject to change without notice.

Order/Technical Support – Tel: (800) 677-5311 / FAX: (800) 677-3865 / www.crouzet-usa.com

DIGITAL I/O MODULE MOUNTING BOARDS

FOR QUAD-PACK MODULES

PB32HQ

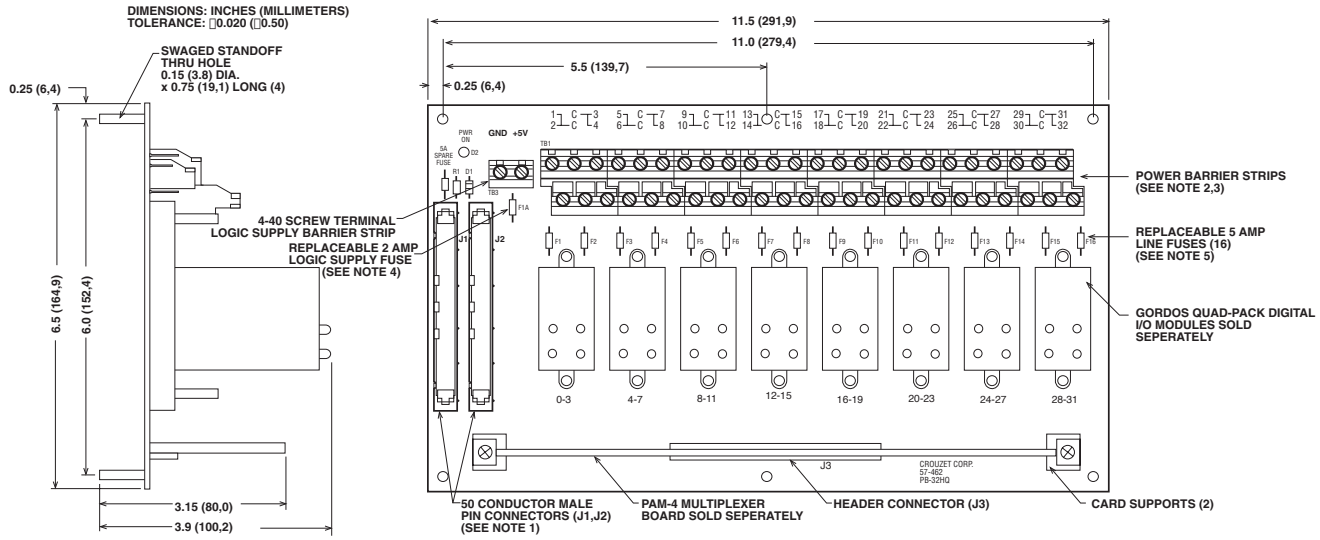

- NOTES: 1) CONNECTOR IS CIRCUIT ASSEMBLY CA-50H-2B-SR OR EQUIVALENT. CONNECTORS ARE WIRED IN PARALLEL.
- 2) 6-32 SCREW TERMINAL BARRIER STRIPS ACCEPT WIRE SIZES FROM 24 TO 12 AWG.
- 3) OPTIONAL JUMPERS AVAILABLE TO INTERCONNECT BARRIER STRIP COMMONS. ORDER 2 EACH JUMPERS "JQ2" AND 4 EACH JUMPERS "JQ4".
- 4) LITTLE FUSE 251001 OR EQUIVALENT.
- 5) LITTLE FUSE 251005 OR EQUIVALENT.

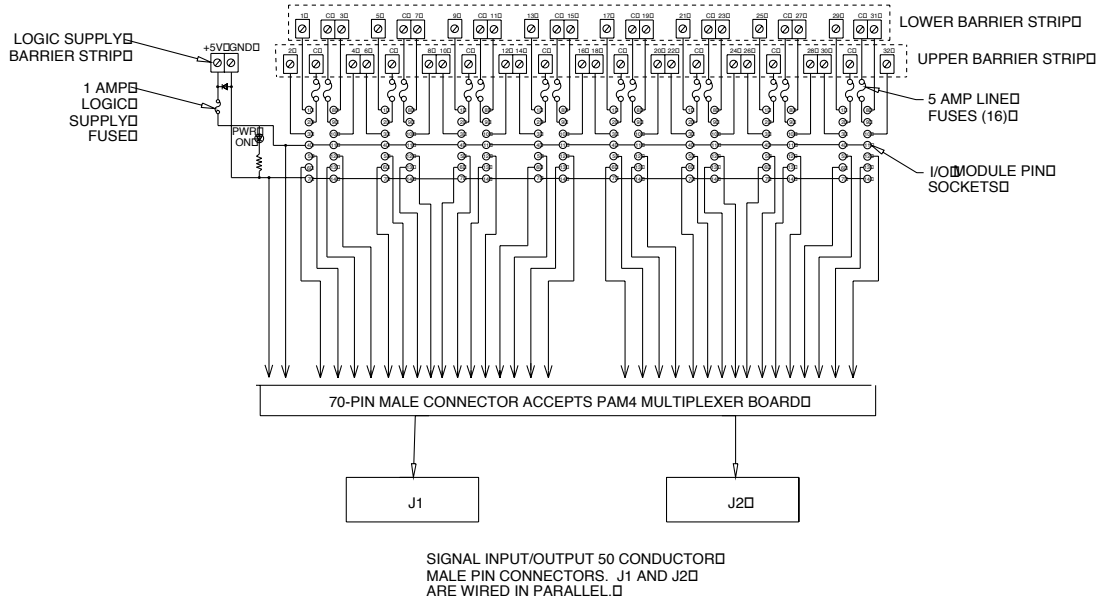

Products and specifications subject to change without notice.

Order/Technical Support – Tel: (800) 677-5311 / FAX: (800) 677-3865 / www.crouzet-usa.com

DIGITAL I/O MODULE MOUNTING BOARDS

FOR "SM" SERIES MINIATURE MODULES

PB8SM

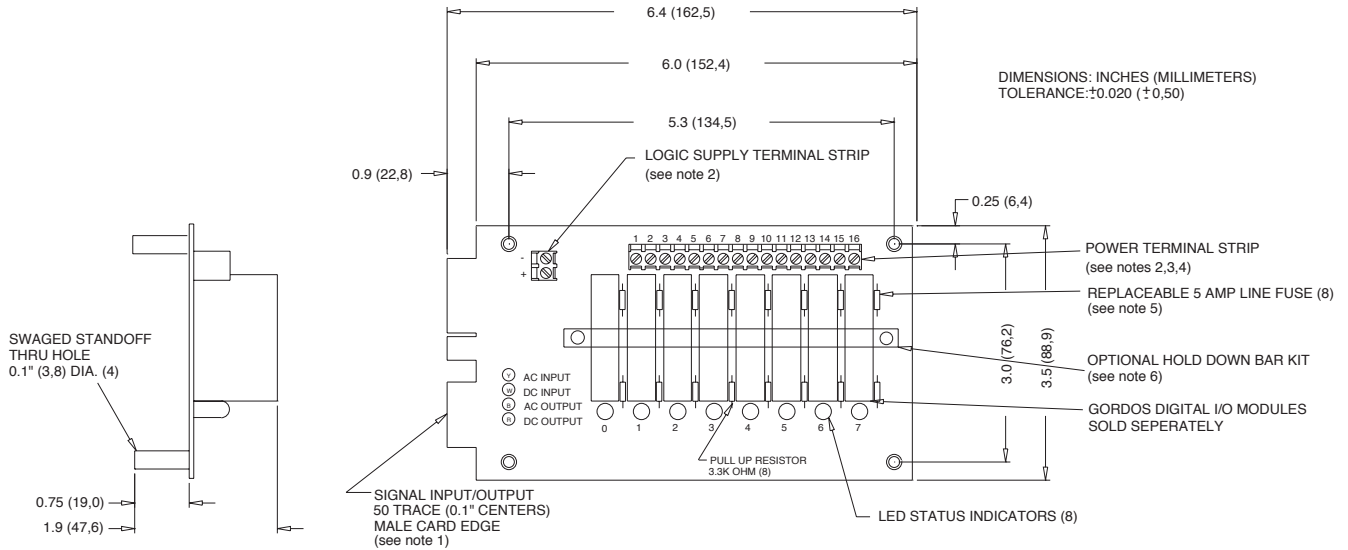

- NOTES: 1) MATING CONNECTOR IS BERG 66317-150 OR EQUIVALENT. SPECIFY SUFFIX 'C' FOR OPTIONAL 65823-093 OR EQUIVALENT MALE PIN CONNECTOR FOR PARALLEL-TO-THE-BOARD CABLE CONNECTION. SPECIFY SUFFIX 'V' FOR OPTIONAL CIRCUIT ASSEMBLY CA-50H-2B-SR OR EQUIVALENT MALE PIN CONNECTOR FOR PERPENDICULAR-TO-THE-BOARD CABLE CONNECTION.
- 2) 4-40 SCREW TERMINAL STRIPS ACCEPT WIRE SIZES FROM 26 TO 14 AWG.
- 3) OPTIONAL JUMPERS ARE AVAILABLE TO INTERCONNECT BARRIER STRIP COMMONS. ORDER 1 EACH "JM8".
- 4) PHOENIX MKD51.5 5.08mm SERIES (OR EQUIVALENT) SCREW TERMINAL BLOCKS STANDARD. SPECIFY SUFFIX "A" FOR BOARD-MOUNTED PHOENIX MSTBVA 1.5/16-G-5.08 (OR EQUIVALENT) MALE CONNECTOR. SPECIFY SUFFIX "B" FOR BOARD-MOUNTED PHOENIX MSTBVA 1.5/16-G-5.08 (OR EQUIVALENT) MALE CONNECTOR AND MATING PHOENIX MSTBVA 1.5/16-ST-5.08 (OR EQUIVALENT) FEMALE, SCREW-TERMINAL PLUG-IN CONNECTOR.
- 5) LITTLE FUSE 251005 OR EQUIVALENT.
- 6) TWO HOLD-DOWN BAR KITS ARE AVAILABLE SEPARATELY. MODEL NO. 11.06.414 EMPLOY A PLAIN ALUMINUM CHANNEL WHILE MODEL NO. 11.06.293 PROVIDES POCKETS IN THE CHANNEL FOR INDIVIDUAL MODULES.

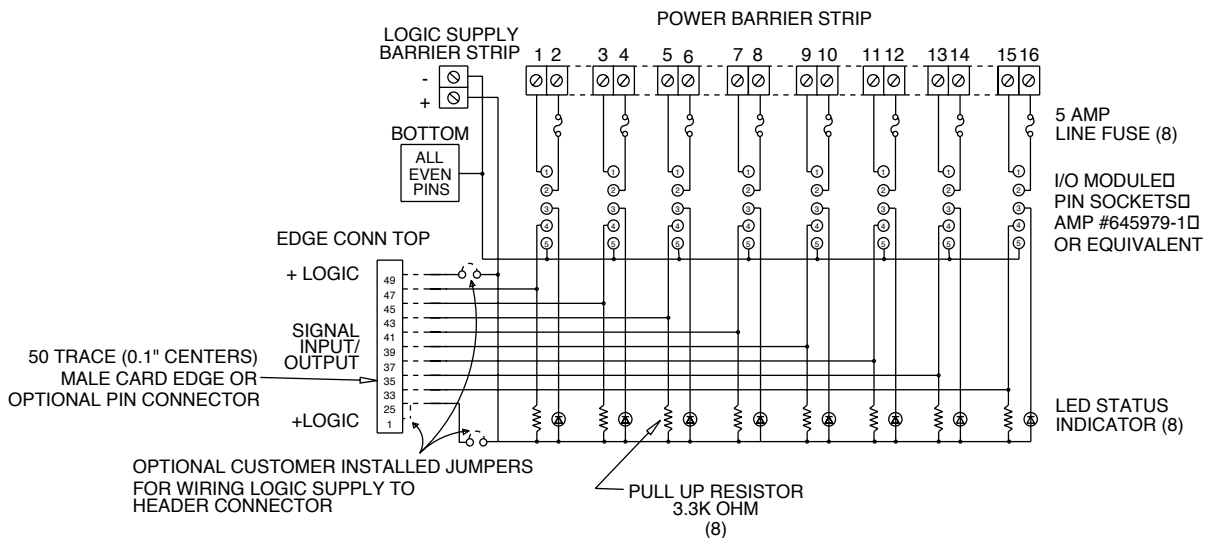

Products and specifications subject to change without notice.

Order/Technical Support – Tel: (800) 677-5311 / FAX: (800) 677-3865 / www.crouzet-usa.com

DIGITAL I/O MODULE MOUNTING BOARDS

FOR "SM" SERIES MINIATURE MODULES

PB16SM

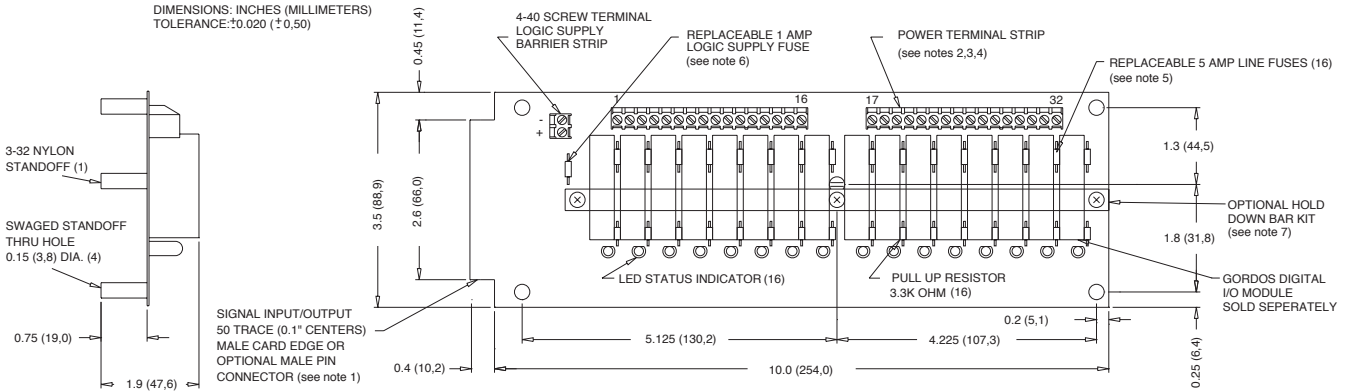

- NOTES: 1) MATING CONNECTOR IS BERG 66317-150 OR EQUIVALENT. SPECIFY SUFFIX 'C' FOR OPTIONAL 65823-093 OR EQUIVALENT MALE PIN CONNECTOR FOR PARALLEL-TO-THE-BOARD CABLE CONNECTION. SPECIFY SUFFIX 'V' FOR OPTIONAL CIRCUIT ASSEMBLY CA-50H-2B-SR OR EQUIVALENT MALE PIN CONNECTOR FOR PERPENDICULAR-TO-THE-BOARD CABLE CONNECTION.
- 2) 6-32 SCREW TERMINAL BARRIER STRIPS ACCEPT WIRE SIZES FROM 24 TO 12 AWG.
- 3) OPTIONAL JUMPERS ARE AVAILABLE TO INTERCONNECT BARRIER STRIP ORDER 1 EACH "JM2" AND 2 EACH "JM8".
- 4) PHOENIX MKD5.1.5.08mm SERIES (OR EQUIVALENT) SCREW TERMINAL BLOCKS STANDARD. SPECIFY SUFFIX "A" FOR BOARD-MOUNTED PHOENIX MSTBVA 1.5/16-G-5.08 (OR EQUIVALENT) MALE CONNECTOR. SPECIFY SUFFIX "B" FOR BOARD-MOUNTED PHOENIX MSTBVA 1.5/16-G-5.08 (OR EQUIVALENT) MALE CONNECTOR AND MATING PHOENIX MSTBVA 1.5/16-ST-5.08 (OR EQUIVALENT) FEMALE. SCREW-TERMINAL PLUG-IN CONNECTOR.
- 5) LITTLE FUSE 251001 OR EQUIVALENT.
- 6) LITTLE FUSE 251005 OR EQUIVALENT.
- 7) TWO HOLD-DOWN BAR KITS ARE AVAILABLE SEPARATELY. MODEL NO. 11.06.415 EMPLOYS A PLAIN ALUMINUM CHANNEL WHILE MODEL NO. 11.06.278 PROVIDES POCKETS IN THE CHANNEL FOR INDIVIDUAL MODULES.

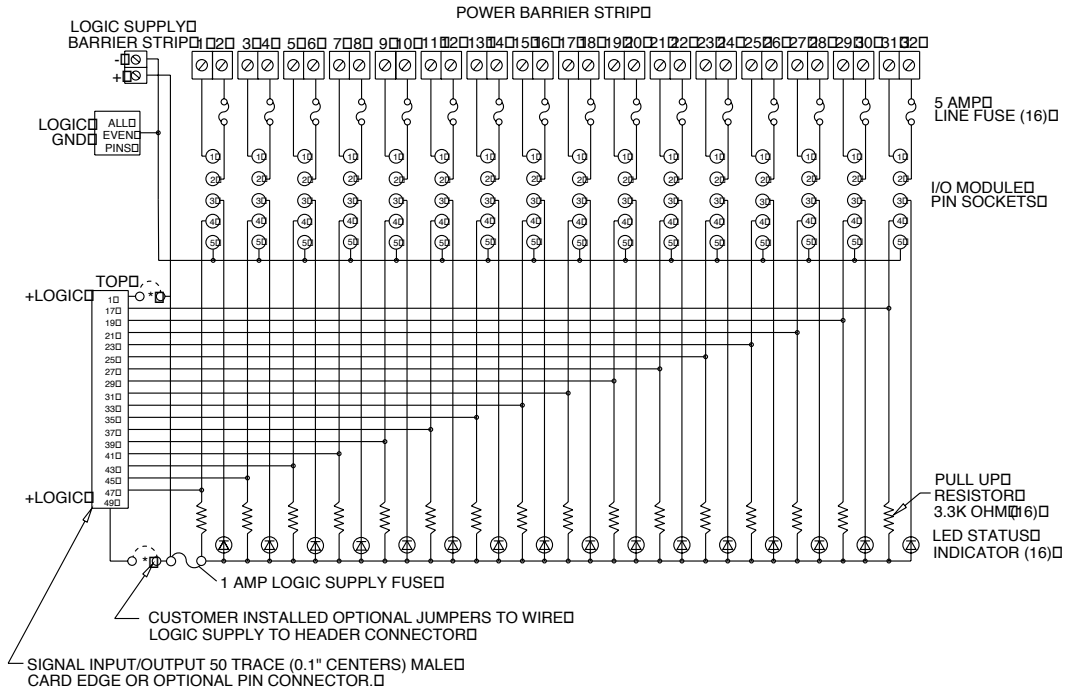

Products and specifications subject to change without notice.

Order/Technical Support – Tel: (800) 677-5311 / FAX: (800) 677-3865 / www.crouzet-usa.com

DIGITAL I/O MODULE MOUNTING BOARDS

FOR "SM" SERIES MINIATURE MODULES

PB16SMH

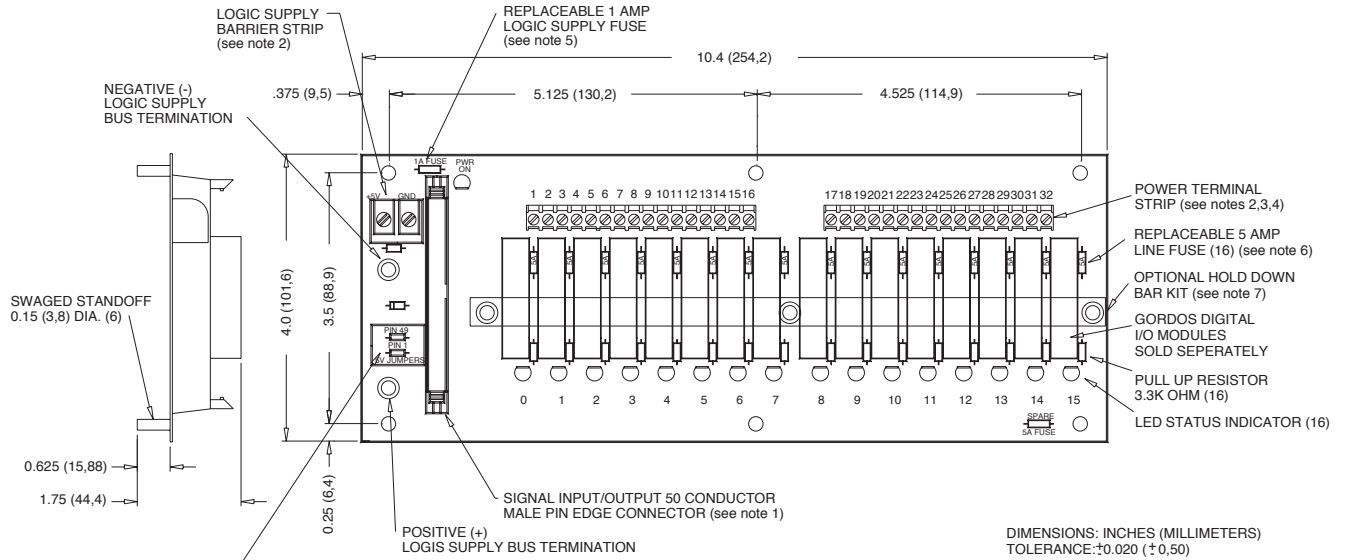

JUMPERS CONNECTING LOGIC SUPPLY THRU HEADER CONNECTOR

- NOTES: 1) CONNECTOR IS CIRCUIT ASSEMBLY CA-50H-2B-SR OR EQUIVALENT.
 2) 4-40 SCREW TERMINAL STRIPS ACCEPT WIRE SIZES FROM 26 TO 14 AWG.
 3) OPTIONAL JUMPERS ARE AVAILABLE TO INTERCONNECT BARRIER STRIP ORDER 1 EACH "JM2" AND 2 EACH "JM8".
 4) PHOENIX MKD51.5 5.08mm SERIES (OR EQUIVALENT) SCREW TERMINAL BLOCKS STANDARD. SPECIFY SUFFIX "A" FOR BOARD-MOUNTED PHOENIX MSTBVA 1.5/16-G-5.08 (OR EQUIVALENT) MALE CONNECTOR. SPECIFY SUFFIX "B" FOR BOARD-MOUNTED PHOENIX MSTBVA 1.5/16-G-5.08 (OR EQUIVALENT) MALE CONNECTOR AND MATING PHOENIX MSTBVA 1.5/16-ST-5.08 (OR EQUIVALENT) FEMALE. SCREW-TERMINAL PLUG-IN CONNECTOR.
 5) LITTLE FUSE 251001 OR EQUIVALENT.
 6) LITTLE FUSE 251005 OR EQUIVALENT.
 7) TWO HOLD-DOWN BAR KITS ARE AVAILABLE SEPARATELY. MODEL NO. 11.06.415 EMPLOY A PLAIN ALUMINUM CHANNEL WHILE MODEL NO. 11.06.278 PROVIDES POCKETS IN THE CHANNEL FOR INDIVIDUAL MODULES.

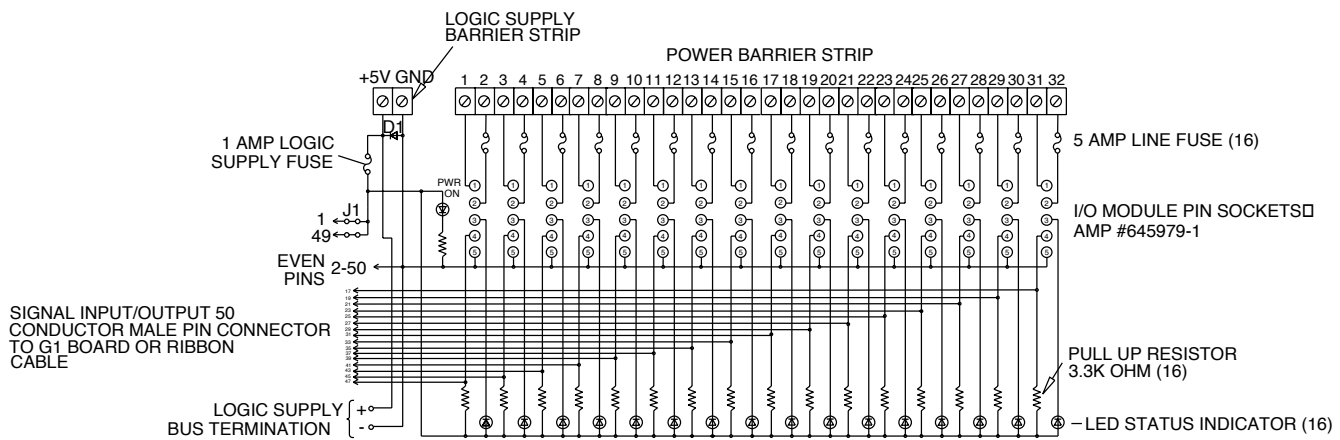

Products and specifications subject to change without notice.

Order/Technical Support – Tel: (800) 677-5311 / FAX: (800) 677-3865 / www.crouzet-usa.com

DIGITAL I/O MODULE MOUNTING BOARDS

FOR "SM" SERIES MINIATURE MODULES

PB24SM

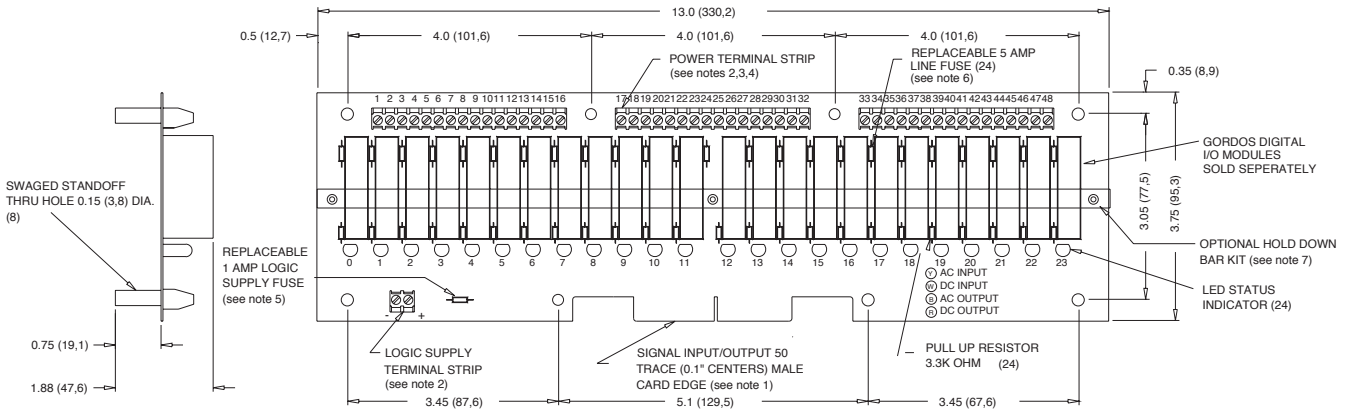

- NOTES: 1) MATING CONNECTOR IS BERG 66317-150 OR EQUIVALENT. SPECIFY SUFFIX 'C' FOR OPTIONAL 65823-093 OR EQUIVALENT MALE PIN CONNECTOR FOR PARALLEL-TO-THE-BOARD CABLE CONNECTION. SPECIFY SUFFIX 'V' FOR OPTIONAL CIRCUIT ASSEMBLY CA-50H-2B-SR OR EQUIVALENT MALE PIN CONNECTOR FOR PERPENDICULAR-TO-THE-BOARD CABLE CONNECTION.
- 2) 4-40 SCREW TERMINAL STRIPS ACCEPT WIRE SIZES FROM 26 TO 14 AWG.
- 3) OPTIONAL JUMPERS ARE AVAILABLE TO INTERCONNECT BARRIER STRIP ORDER 3 EACH "JMB".
- 4) PHOENIX MKD51.5 5.08mm SERIES (OR EQUIVALENT) SCREW TERMINAL BLOCKS STANDARD. SPECIFY SUFFIX "A" FOR BOARD-MOUNTED PHOENIX MSTBVA 1.5/16-G-5.08 (OR EQUIVALENT) MALE CONNECTOR. SPECIFY SUFFIX "B" FOR BOARD-MOUNTED PHOENIX MSTBVA 1.5/16-G-5.08 (OR EQUIVALENT) MALE CONNECTOR AND MATING PHOENIX MSTBVA 1.5/16-ST-5.08 (OR EQUIVALENT) FEMALE SCREW-TERMINAL PLUG-IN CONNECTOR.
- 5) LITTLE FUSE 251001 OR EQUIVALENT.
- 6) LITTLE FUSE 251005 OR EQUIVALENT.
- 7) TWO HOLD-DOWN BAR KITS ARE AVAILABLE SEPARATELY. MODEL NO. 11.06.413 EMPLOYS A PLAIN ALUMINUM CHANNEL WHILE MODEL NO. 11.06.288 PROVIDES POCKETS IN THE CHANNEL FOR INDIVIDUAL MODULES.

DIMENSIONS: INCHES (MILLIMETERS)
TOLERANCE: ±0.020 (±0.50)

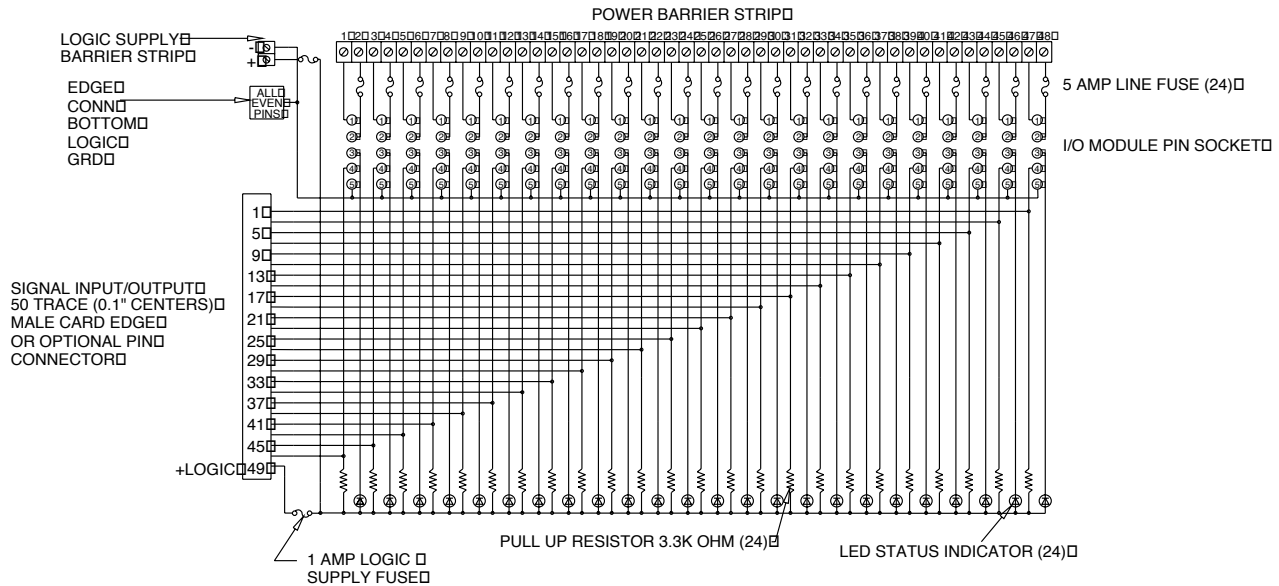

Products and specifications subject to change without notice.

Order/Technical Support – Tel: (800) 677-5311 / FAX: (800) 677-3865 / www.crouzet-usa.com

DIGITAL I/O MODULE MOUNTING BOARDS

FOR "SM" SERIES MINIATURE MODULES

PB32SM

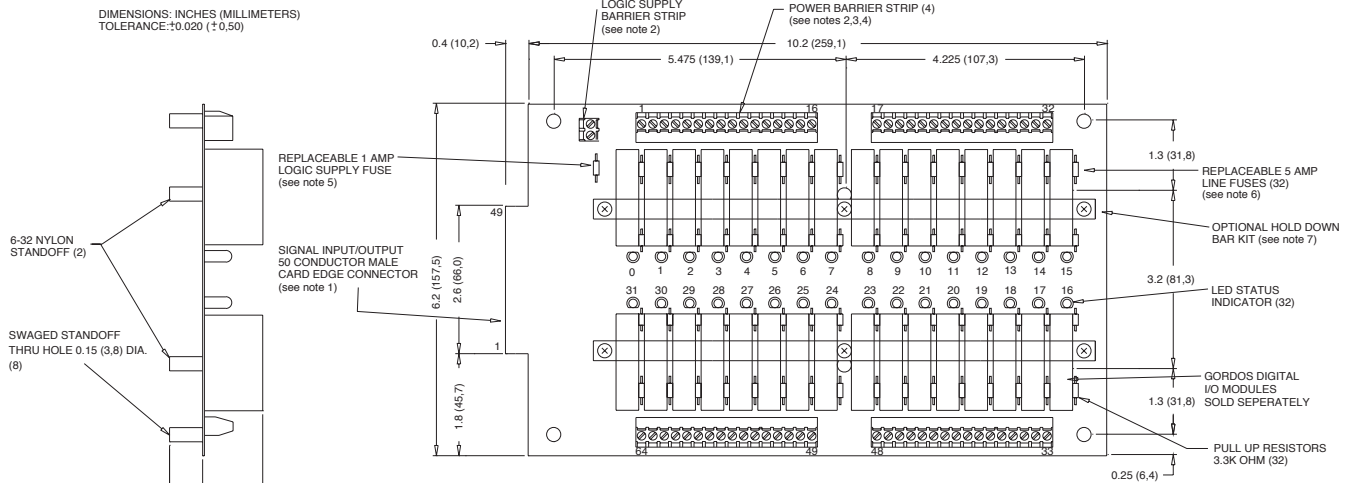

- NOTES: 1) MATING CONNECTOR IS BERG 66317-150 OR EQUIVALENT. SPECIFY SUFFIX 'C' FOR OPTIONAL 65623-093 OR EQUIVALENT MALE PIN CONNECTOR FOR PARALLEL-TO-THE-BOARD CABLE CONNECTION. SPECIFY SUFFIX 'V' FOR OPTIONAL CIRCUIT ASSEMBLY CA-50H-2B-SR OR EQUIVALENT MALE PIN CONNECTOR FOR PERPENDICULAR-TO-THE-BOARD CABLE CONNECTION.
- 2) BARRIER STRIPS ACCEPT WIRE SIZES FROM 26 TO 14 AWG.
- 3) OPTIONAL JUMPERS ARE AVAILABLE TO INTERCONNECT BARRIER STRIP. ORDER 2 EACH "JIM2" AND 4 EACH "JIM8".
- 4) PHOENIX MKD51 5 5.08mm SERIES (OR EQUIVALENT) SCREW TERMINAL BLOCKS STANDARD. SPECIFY SUFFIX "A" FOR BOARD-MOUNTED PHOENIX MSTBVA 1.5/16-G-5.08 (OR EQUIVALENT) MALE CONNECTOR. SPECIFY SUFFIX "B" FOR BOARD-MOUNTED PHOENIX MSTBVA 1.5/16-G-5.08 (OR EQUIVALENT) MALE CONNECTOR AND MATING PHOENIX MSTBVA 1.5/16-ST-5.08 (OR EQUIVALENT) FEMALE. SCREW-TERMINAL PLUG-IN CONNECTOR.
- 5) LITTLE FUSE 251001 OR EQUIVALENT.
- 6) LITTLE FUSE 251005 OR EQUIVALENT.
- 7) OPTIONAL HOLD DOWN BAR KITS AVAILABLE. ORDER KIT 11.06.418 FOR LOW COST CLAMPING VERSION, OR KIT 11.06.305 FOR FULLY RETAINED VERSION.

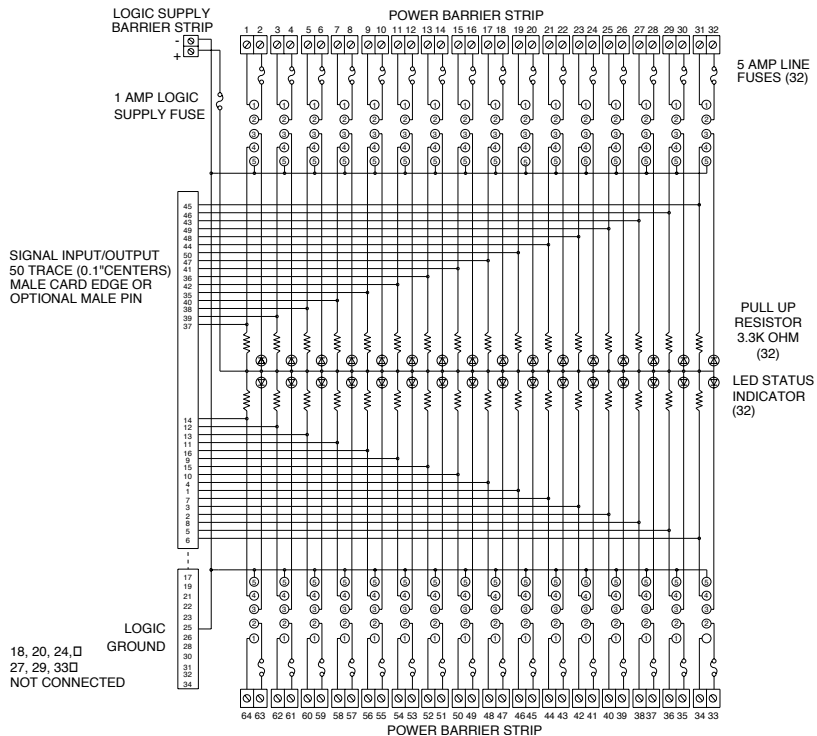

Products and specifications subject to change without notice.

Order/Technical Support – Tel: (800) 677-5311 / FAX: (800) 677-3865 / www.crouzet-usa.com

DIGITAL I/O MODULE MOUNTING BOARDS

FOR C4 MODULES

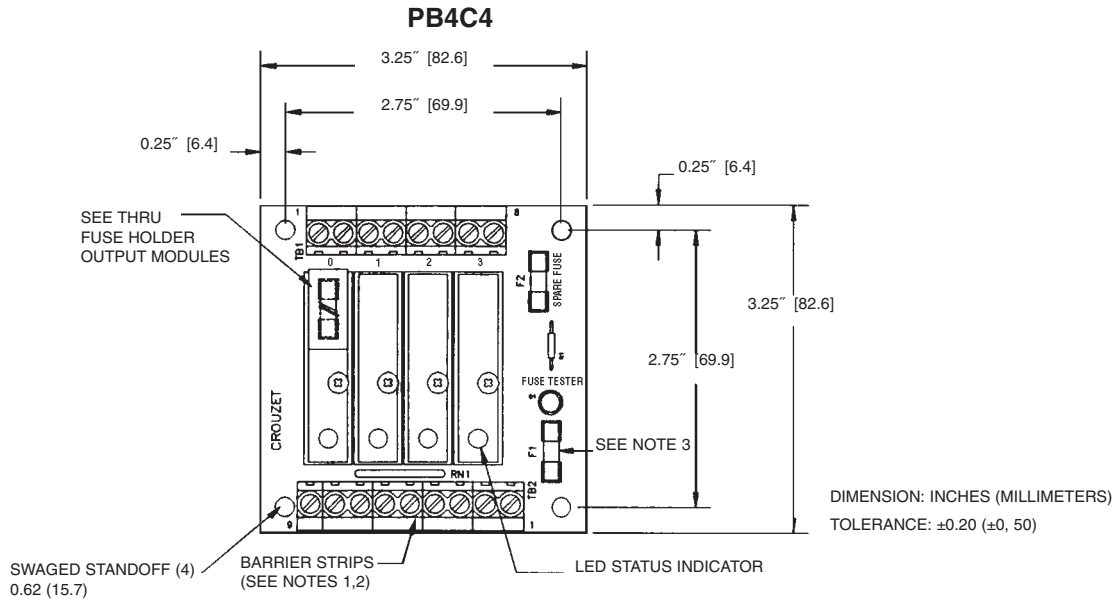

- NOTES: 1) BARRIER STRIP IS PHOENIX MKDS5/X 6.35mm
 2) ACCEPTS UP TO 10 AWG WIRE
 3) LITTLE FUSE 229003S OR EQUIVALENT

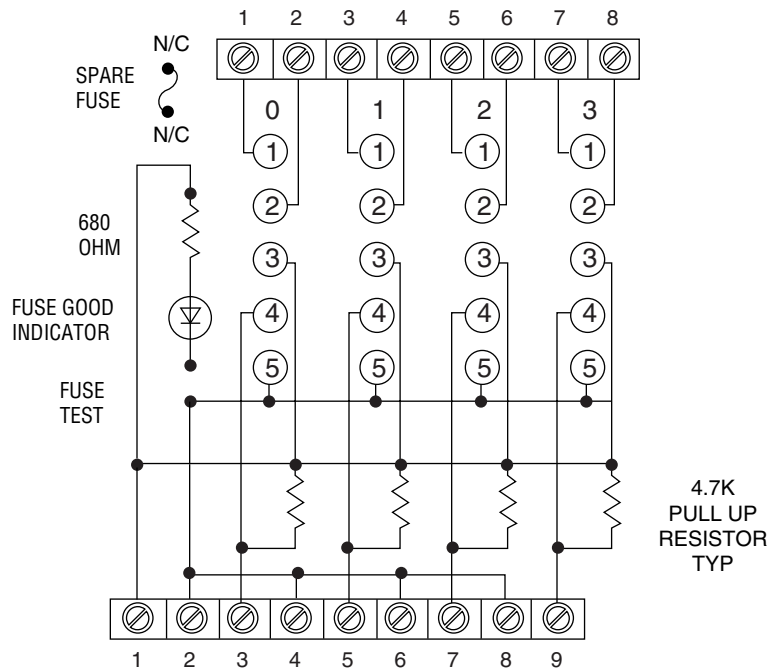

Products and specifications subject to change without notice.

Order/Technical Support – Tel: (800) 677-5311 / FAX: (800) 677-3865 / www.crouzet-usa.com

DIGITAL I/O MODULE MOUNTING BOARDS

FOR C4 MODULES

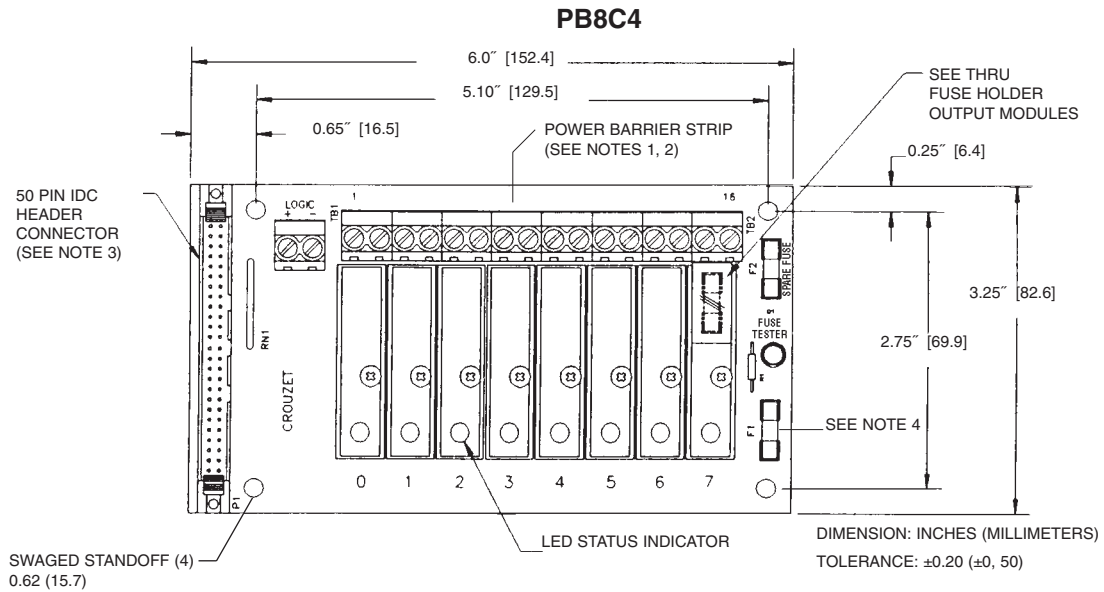

- NOTES: 1) BARRIER STRIP IS PHOENIX MKDS5/X 6.35mm
 2) ACCEPTS UP TO 10 AWG WIRE
 3) CONNECTOR IS CIRCUIT ASSEMBLY CA-50H-2B OR EQUIVALENT
 4) LITTLE FUSE 229003S OR EQUIVALENT

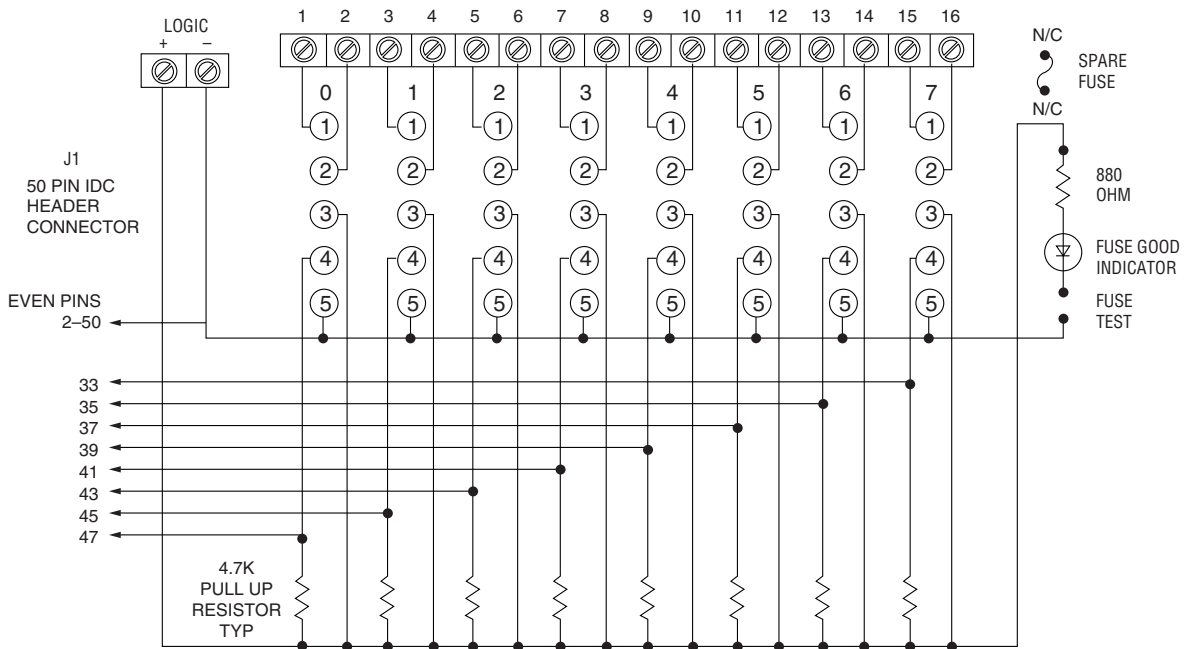

Products and specifications subject to change without notice.

Order/Technical Support – Tel: (800) 677-5311 / FAX: (800) 677-3865 / www.crouzet-usa.com

DIGITAL I/O MODULE MOUNTING BOARDS

FOR C4 MODULES

PB16C4

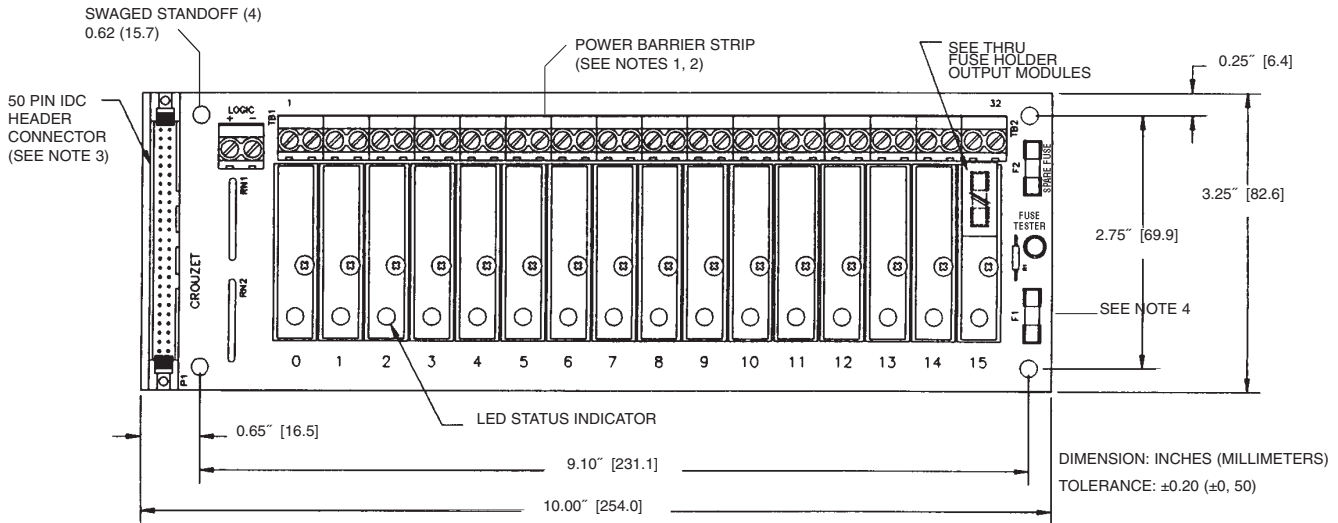

- NOTES: 1) BARRIER STRIP IS PHOENIX MKDS5/X 6.35mm
2) ACCEPTS UP TO 10 AWG WIRE
3) CONNECTOR IS CIRCUIT ASSEMBLY CA-50H-2B OR EQUIVALENT
4) LITTLE FUSE 229003S OR EQUIVALENT

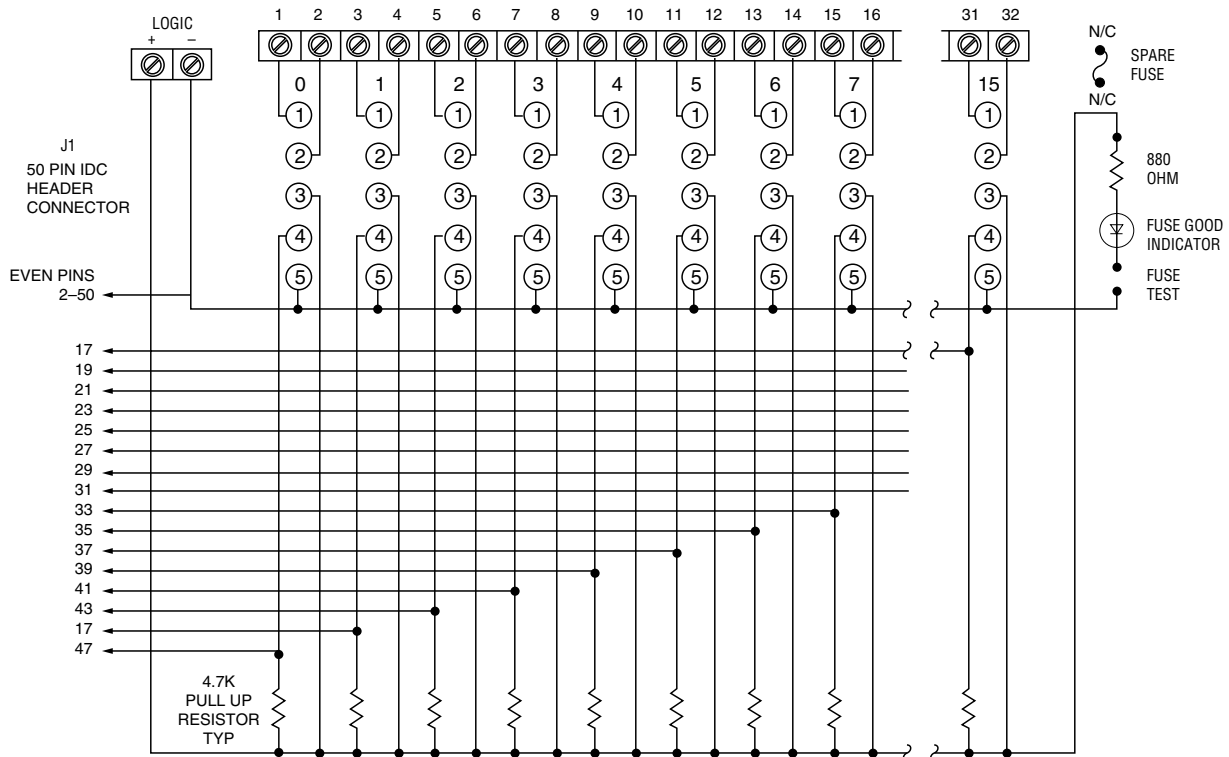

Products and specifications subject to change without notice.

Order/Technical Support – Tel: (800) 677-5311 / FAX: (800) 677-3865 / www.crouzet-usa.com

DIGITAL I/O MODULE MOUNTING BOARDS

FOR C4 MODULES

PB16C4T

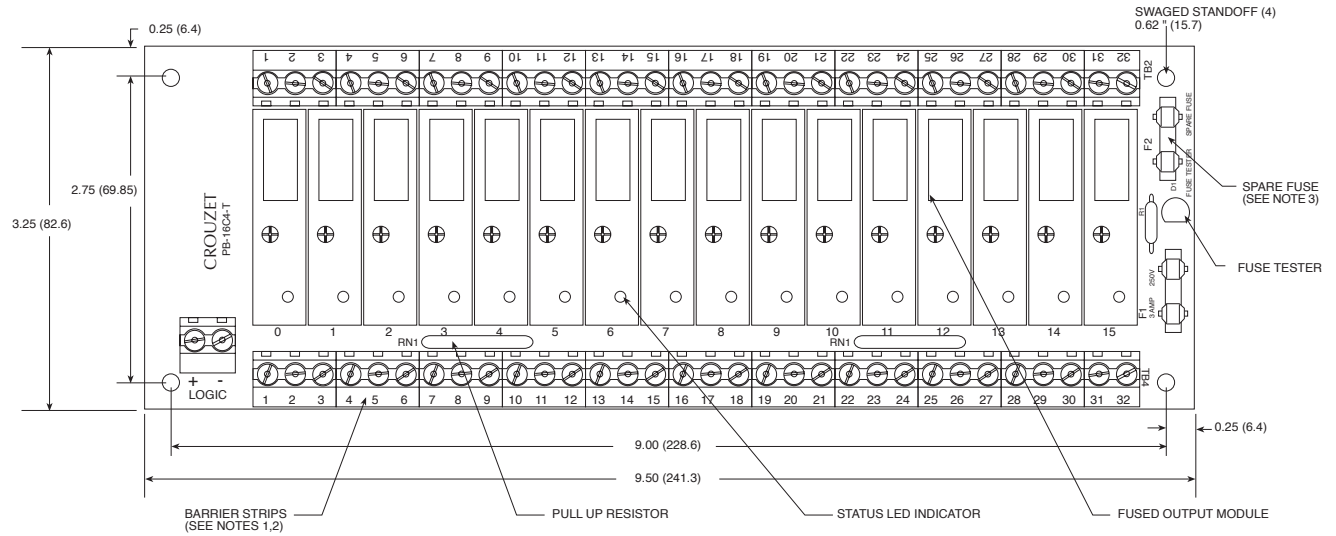

- NOTES:
- 1) BARRIER STRIP IS PHOENIX MKDS5/X 6.35mm
 - 2) ACCEPTS UP TO 10 AWG WIRE
 - 3) LITTLE FUSE 229003S OR EQUIVALENT

PB16C4T

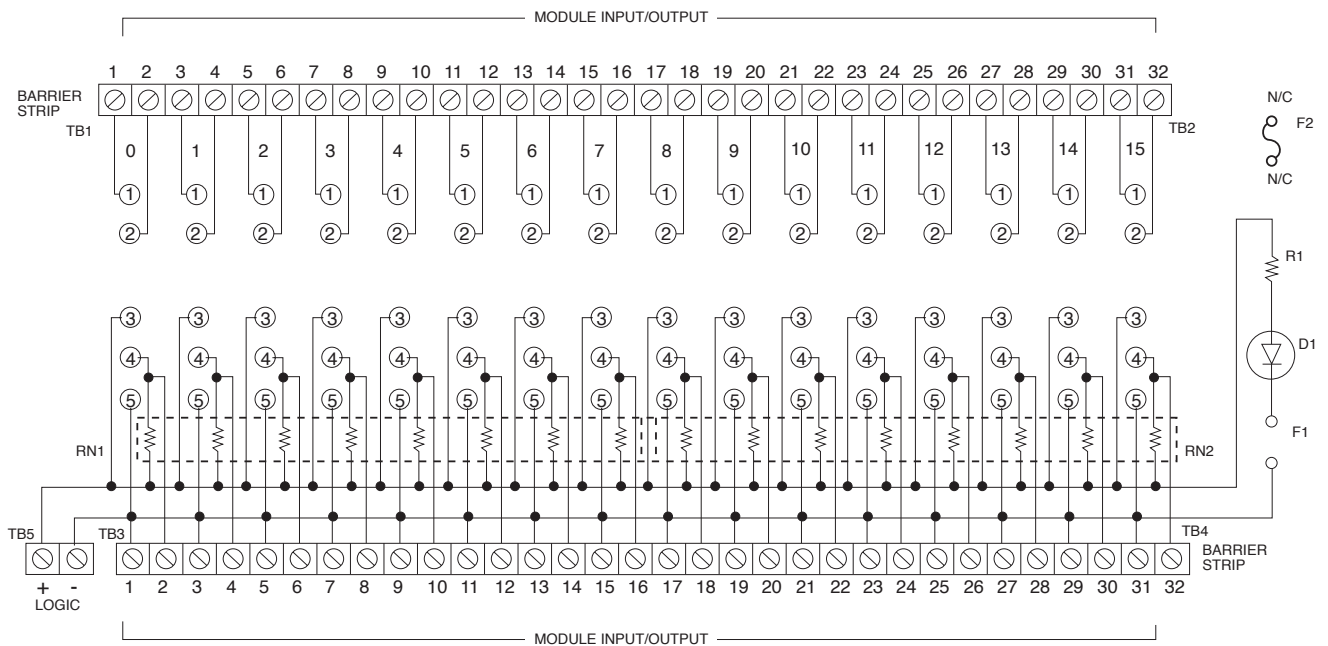

Products and specifications subject to change without notice.

Order/Technical Support – Tel: (800) 677-5311 / FAX: (800) 677-3865 / www.crouzet-usa.com

DIGITAL I/O MODULE MOUNTING BOARDS

FOR C4 MODULES

PB24C4

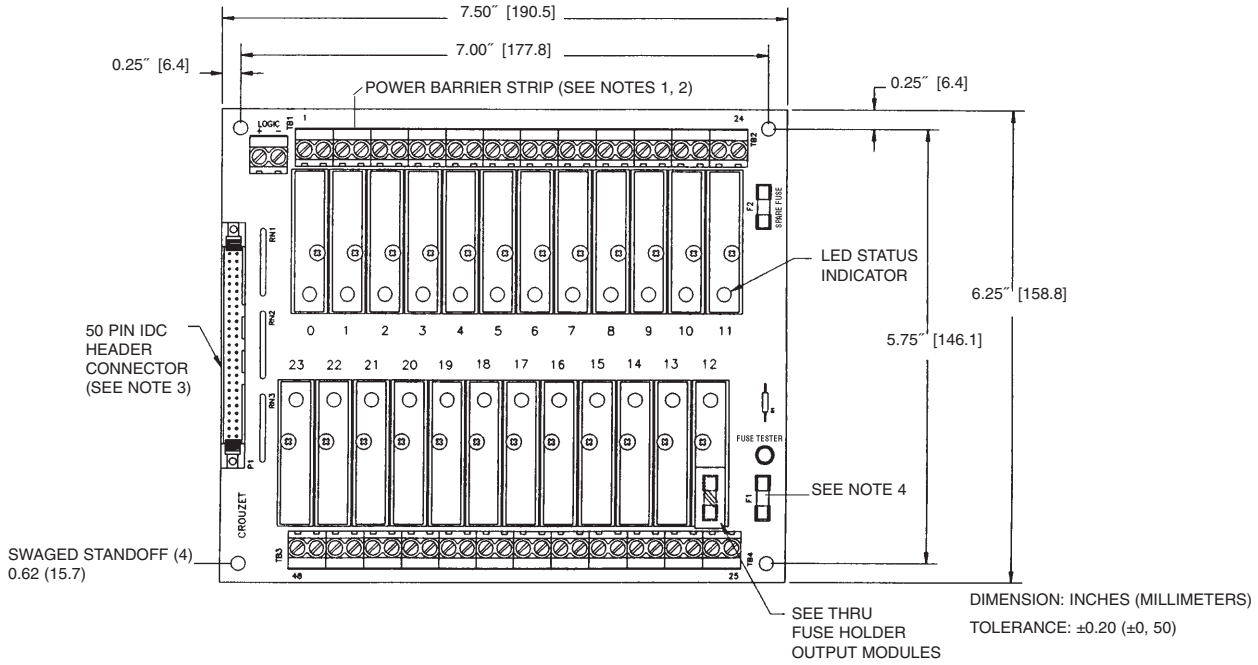

- NOTES: 1) BARRIER STRIP IS PHOENIX MKDS5/X 6.35mm
 2) ACCEPTS UP TO 10 AWG WIRE
 3) CONNECTOR IS CIRCUIT ASSEMBLY CA-50H-2B OR EQUIVALENT
 4) LITTLE FUSE 229003S OR EQUIVALENT

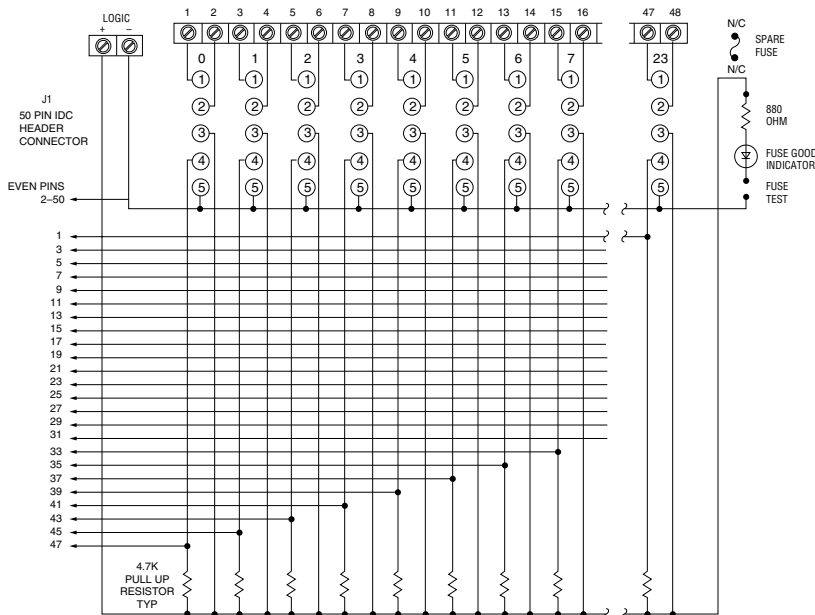

Products and specifications subject to change without notice.

Order/Technical Support – Tel: (800) 677-5311 / FAX: (800) 677-3865 / www.crouzet-usa.com

DIGITAL I/O MODULE MOUNTING BOARDS

FOR C4 MODULES

PB32C4

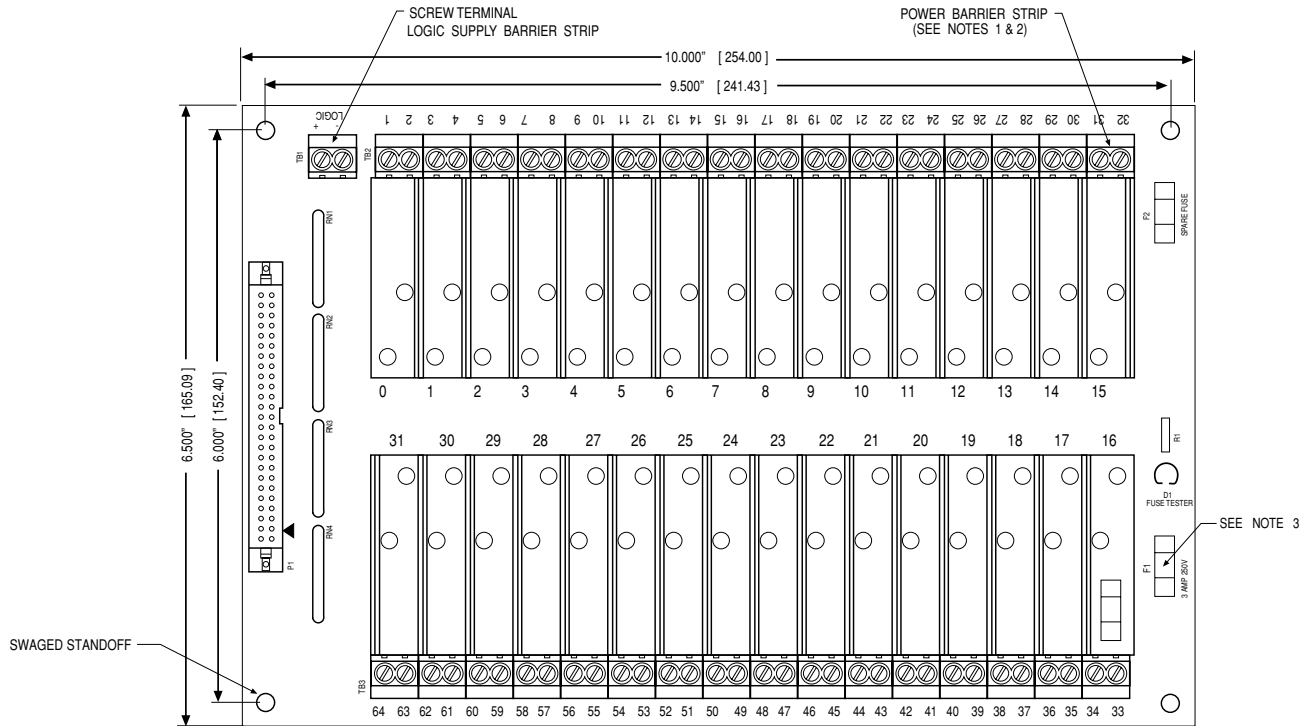

DIMENSIONS: INCHES (MILLIMETERS)
TOLERANCE: ± .020 (± 0.50)

- Notes:
- 1) BARRIER STRIP IS PHOENIX MKDS5/X 6.35mm
 - 2) ACCEPTS UP TO 10 AWG WIRE
 - 3) LITTLE FUSE 229003S OR EQUIVALENT

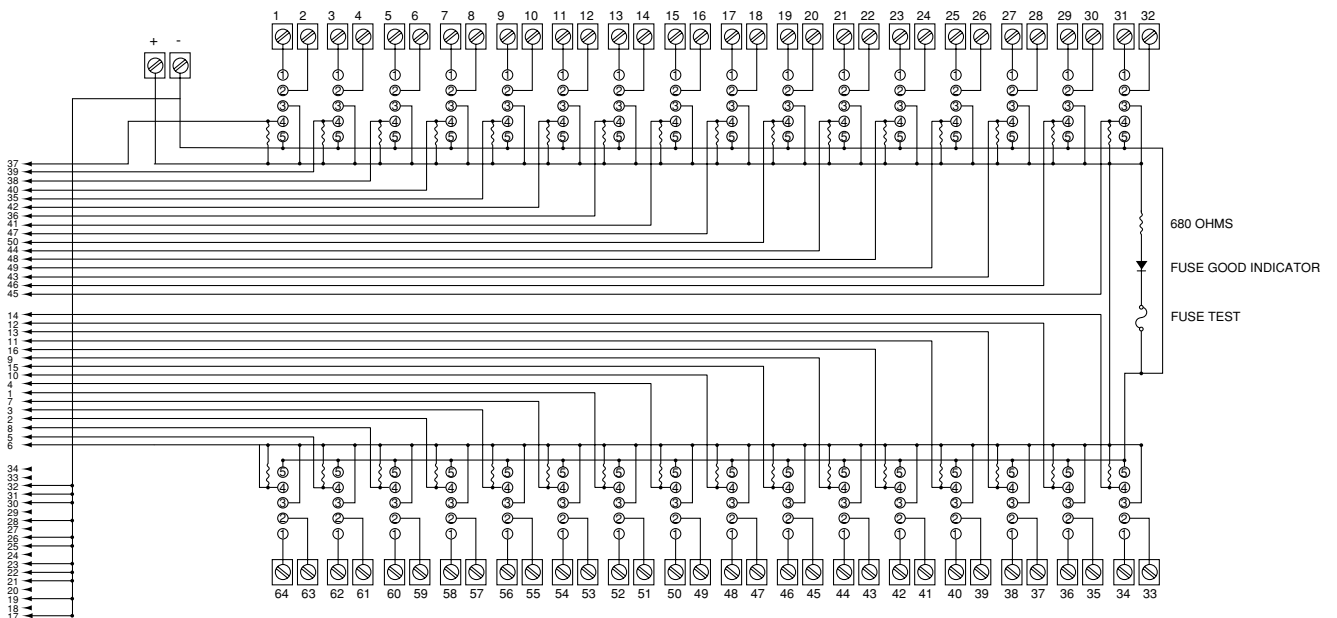

Products and specifications subject to change without notice.

Order/Technical Support – Tel: (800) 677-5311 / FAX: (800) 677-3865 / www.crouzet-usa.com

DIGITAL I/O MODULE MOUNTING BOARDS

HEADER CONNECTOR OPTION

"-C" CONNECTOR OPTION (1)

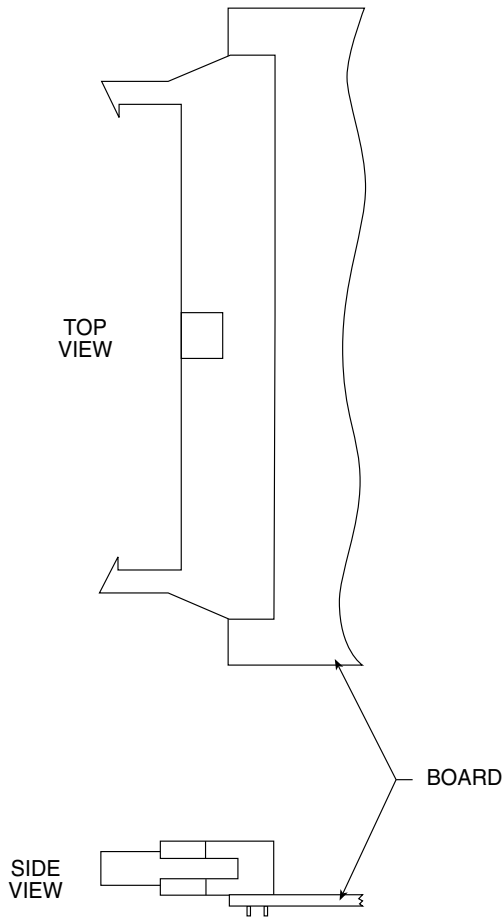

"-V" CONNECTOR OPTION (2)

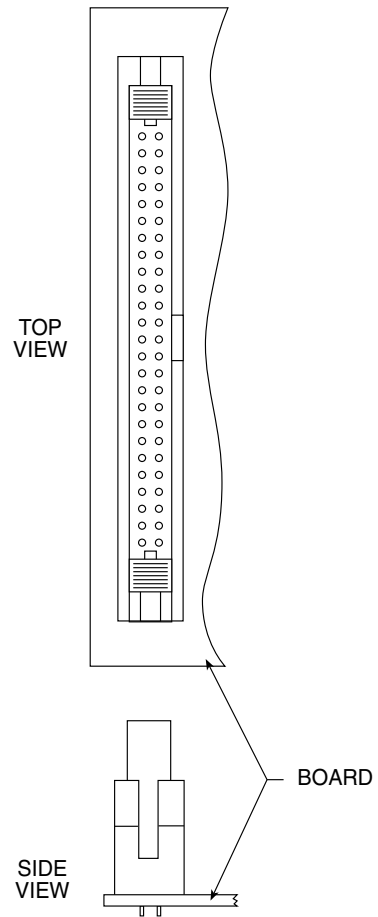

NOTES: 1.) CONNECTOR IS BERG 65823-093 OR EQUIVALENT
 2.) CONNECTOR IS CIRCUIT ASSEMBLY CA-50H-2B OR EQUIVALENT

TERMINAL OPTIONS FOR "M" AND "SM" I/O MOUNTING BOARDS

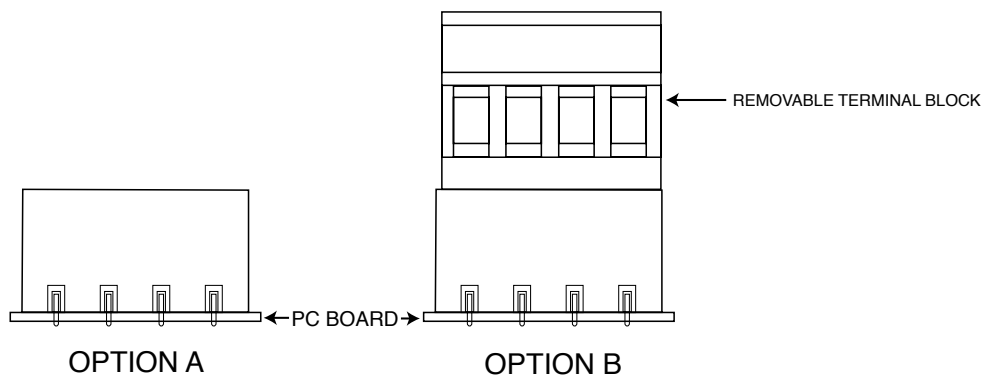

Products and specifications subject to change without notice.

Order/Technical Support – Tel: (800) 677-5311 / FAX: (800) 677-3865 / www.crouzet-usa.com

DIGITAL SYSTEM ACCESSORIES

JUMPERS FOR I/O DIGITAL MODULE MOUNTING BOARDS

The J-series of copper jumpers are used to connect the common ("C" labeled) terminals of digital I/O module mounting boards. The two-position jumpers are used for electrical connection between barrier strips, and the 4 or 8-position jumpers connect common points

within a barrier strip. All jumpers are made from 0.031 ±0.002 inch thick copper and plated with bright tin. The JS, JM, JQ and JC4 jumpers are used with mounting boards for 0.6", M / SM series, Quad-pack and C4 modules respectively.

MODEL # JM2

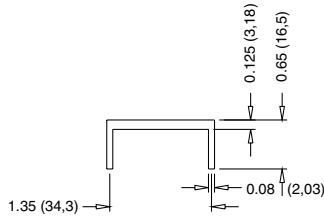

MATERIAL: 0.031" (0,787) TIN PLATED COPPER
 DIMENSIONS: INCHES (MILLIMETERS)
 TOLERANCE: ±0.020 (±0,50)

MODEL # JM8

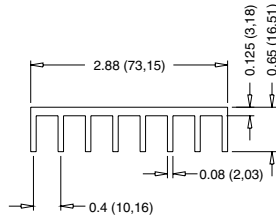

MATERIAL: 0.031" (0,787) TIN PLATED COPPER
 DIMENSIONS: INCHES (MILLIMETERS)
 TOLERANCE: ±0.020 (±0,50)

MODEL # JQP2

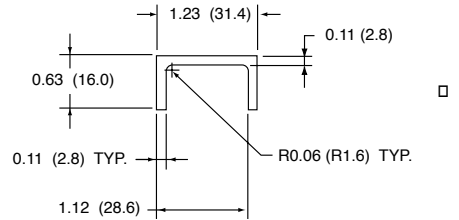

DIMENSIONS ARE IN INCHES (MILLIMETERS).

MODEL # JQP4

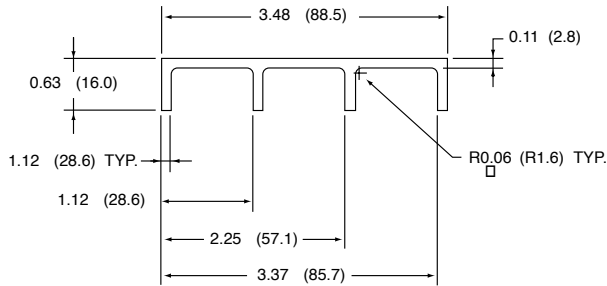

DIMENSIONS ARE IN INCHES (MILLIMETERS).

MODEL # JS8

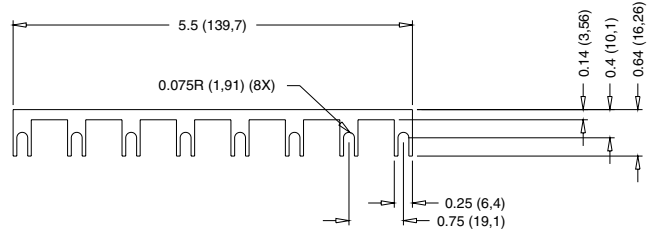

MATERIAL: 0.031" (,787) TIN PLATED COPPER
 DIMENSIONS: INCHES (MILLIMETERS)
 TOLERANCE: ±0.020 (±0,50)

MODEL # JS2

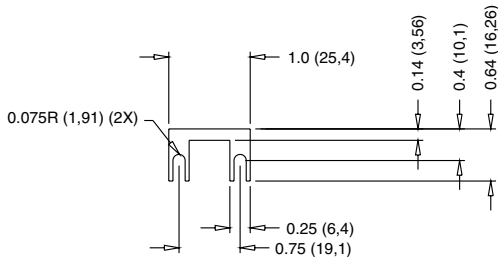

MATERIAL: 0.031" (,787) TIN PLATED COPPER
 DIMENSIONS: INCHES (MILLIMETERS)
 TOLERANCE: ±0.020 (±0,50)

MODEL # JC48

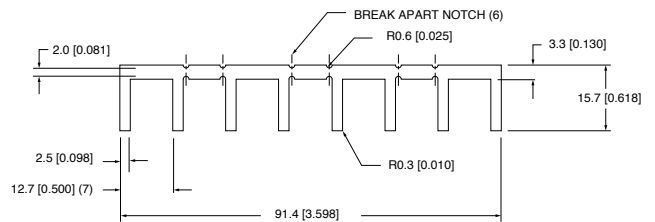

MATERIAL: 0.787 [0.031] TIN PLATED COPPER
 DIMENSIONS: MILLIMETERS [INCHES]
 TOLERANCE: ±0.5 [0.020]

Products and specifications subject to change without notice.

Order/Technical Support – Tel: (800) 677-5311 / FAX: (800) 677-3865 / www.crouzet-usa.com

DIGITAL SYSTEM ACCESSORIES

DIGITAL I/O MODULE HOLD DOWN BAR KITS

Gordos hold-down bar kits for M and SM series I/O module mounting boards provide positive module retention in applications subject to shock and vibration. Two styles are available. One employs a plain aluminum channel to

clamp the modules to the board, while the other employs a pocketed channel to assure module alignment as well. All hold-down bar kits include bar(s), spacers and screws.

MODEL # 11.06.278

HOLD-DOWN BAR KIT NUMBER 11-06-278

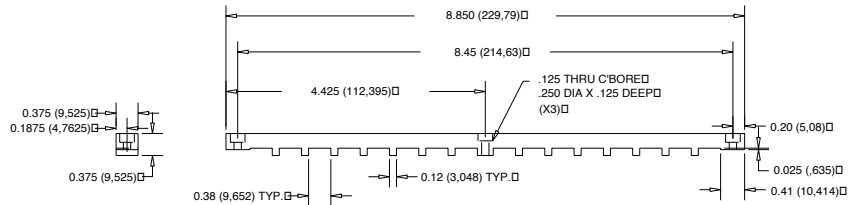

MATERIAL: ALUMINUM, BLACK ANODIZED

KIT INCLUDES 1 EACH HOLD-DOWN BAR, 3 EACH 4-40X1.5" MACHINE SCREWS, AND 3 EACH 1"X.250" DIA NYLON SPACERS

INTENDED FOR USE WITH GORDOS PB-16M OR PB-16SM I/O MODULE MOUNTING BOARDS

DIMENSIONS: INCHES (MILLIMETERS) TOLERANCE: ±0.020 (±0.50)

MODEL # 11.06.288

HOLD-DOWN BAR KIT NUMBER 11-06-288

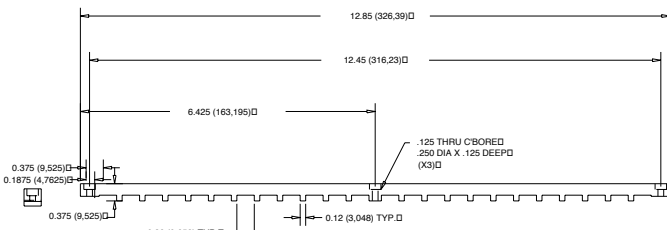

MATERIAL: ALUMINUM, BLACK ANODIZED

KIT INCLUDES 1 EACH HOLD-DOWN BAR, 3 EACH 4-40X1.5" MACHINE SCREWS, AND 3 EACH 1"X.250" DIA NYLON SPACERS

INTENDED FOR USE WITH GORDOS PB-24M OR PB-24SM I/O MODULE MOUNTING BOARDS

DIMENSIONS: INCHES (MILLIMETERS) TOLERANCE: ±0.020 (±0.50)

MODEL # 11.06.293

HOLD-DOWN BAR KIT 11-06-293

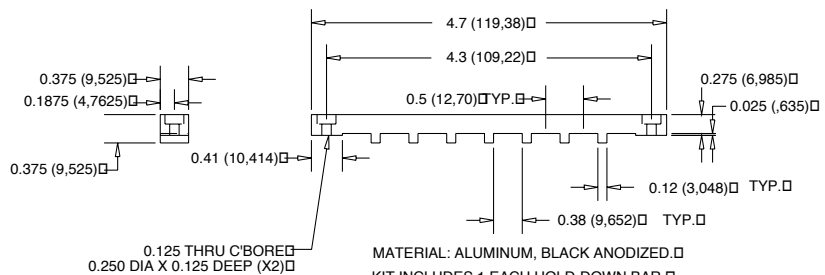

MATERIAL: ALUMINUM, BLACK ANODIZED

KIT INCLUDES 1 EACH HOLD-DOWN BAR, 2 EACH 4-40X1.5" MACHINE SCREWS, AND 2 EACH 1"X.250" DIA NYLON SPACERS

INTENDED FOR USE WITH GORDOS PB-8M OR PB-8SM I/O MODULE MOUNTING BOARDS

DIMENSIONS: INCHES (MILLIMETERS) TOLERANCE: ±0.020 (±0.50)

MODEL # 11.06.305

HOLD-DOWN BAR KIT NUMBER 11-06-305

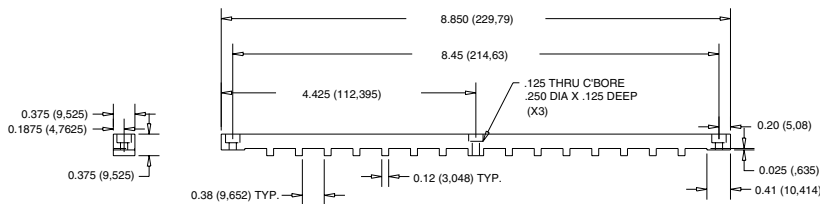

MATERIAL: ALUMINUM, BLACK ANODIZED.

KIT INCLUDES 2 EACH HOLD-DOWN BARS, 6 EACH 4-40X1.5" MACHINE SCREWS, AND 6 EACH 1"X.250" DIA NYLON SPACERS.

INTENDED FOR USE WITH GORDOS PB-32M OR PB-32SM I/O MODULE MOUNTING BOARDS.

DIMENSIONS: INCHES (MILLIMETERS) TOLERANCE: ±0.020 (±0.50)

Products and specifications subject to change without notice.

Order/Technical Support – Tel: (800) 677-5311 / FAX: (800) 677-3865 / www.crouzet-usa.com

DIGITAL SYSTEM ACCESSORIES

DIGITAL I/O MODULE HOLD DOWN BAR KITS

MODEL # 11.06.413

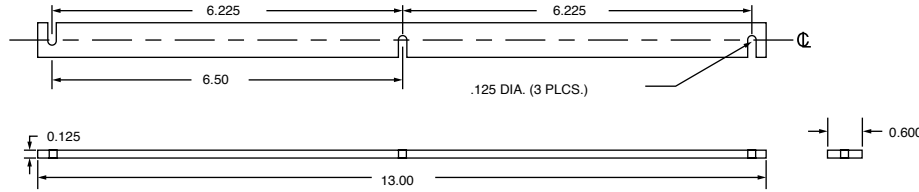

MATERIAL: .125" BLACK ANODIZED ALUMINUM
 KIT INCLUDES 1 EACH HOLD-DOWN BAR
 3 EACH WASHER FACED THUMB SCREW
 3 EACH 15/16" x 3/16" DIA ALUMINUM SPACERS
 INTENDED FOR USE ON GORDOS PB-24M OR
 PB-24SM I/O MODULE MOUNTING BOARDS.
 DIMENSIONS: INCHES
 TOLERANCE: ± 0.020

MODEL # 11.06.414

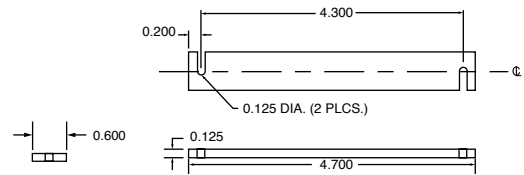

MATERIAL: .125" BLACK ANODIZED ALUMINUM
 KIT INCLUDES 1 EACH HOLD-DOWN BAR
 2 EACH WASHER FACED THUMB SCREW
 2 EACH 15/16" x 3/16" DIA ALUMINUM SPACERS
 INTENDED FOR USE ON GORDOS PB-8M OR
 PB-8SM I/O MODULE MOUNTING BOARDS.
 DIMENSIONS: INCHES
 TOLERANCE: ± 0.020

MODEL # 11.06.415

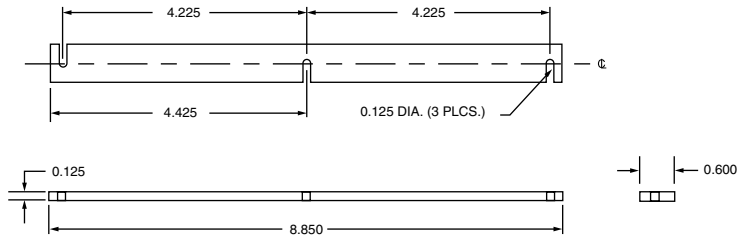

MATERIAL: .125" BLACK ANODIZED ALUMINUM
 KIT INCLUDES 1 EACH HOLD-DOWN BAR
 3 EACH WASHER FACED THUMB SCREW
 3 EACH 15/16" x 3/16" DIA ALUMINUM SPACERS
 INTENDED FOR USE ON GORDOS PB-16M OR
 PB-16SM I/O MODULE MOUNTING BOARDS.
 DIMENSIONS: INCHES
 TOLERANCE: ± 0.020

MODEL # 11.06.418

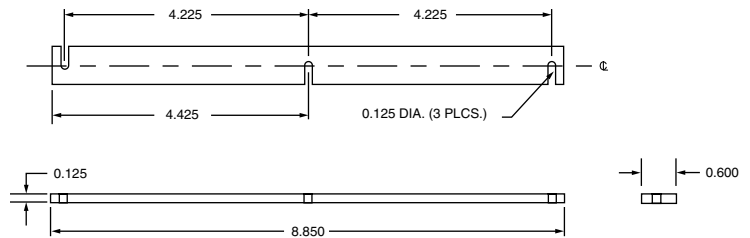

MATERIAL: .125" BLACK ANODIZED ALUMINUM
 KIT INCLUDES 2 EACH HOLD-DOWN BAR
 6 EACH WASHER FACED THUMB SCREW
 6 EACH 15/16" x 3/16" DIA ALUMINUM SPACERS
 INTENDED FOR USE ON GORDOS PB-32M OR
 PB-32SM I/O MODULE MOUNTING BOARDS.
 DIMENSIONS: INCHES
 TOLERANCE: ± 0.020

Products and specifications subject to change without notice.

Order/Technical Support – Tel: (800) 677-5311 / FAX: (800) 677-3865 / www.crouzet-usa.com



Products and specifications subject to change without notice.

Order/Technical Support – Tel: (800) 677-5311 / FAX: (800) 677-3865 / www.crouzet-usa.com



Products and specifications subject to change without notice.

Order/Technical Support – Tel: (800) 677-5311 / FAX: (800) 677-3865 / www.crouzet-usa.com



Products and specifications subject to change without notice.

Order/Technical Support – Tel: (800) 677-5311 / FAX: (800) 677-3865 / www.crouzet-usa.com