

DC Output Modules

D4-16TD1 DC Output <--->	
Outputs per Module	16 (current sinking)
Commons per Module	2 internally connected
Operating Voltage	4.5-26.4VDC
Output Type	NPN Open collector
Peak Voltage	40VDC
ON Voltage Drop	0.5VDC @ 0.5A 0.2VDC @ 0.1A
Max Current (resistive)	0.5A/point - 3A/common
Max Leakage Current	0.1mA @ 40VDC
Max Inrush Current	2A for 10ms 1A for 100ms
Minimum Load	0.2mA
Base Power Required 5V	200mA max
External DC Required	24VDC \pm 10% @ 125mA
OFF to ON Response	0.5ms
ON to OFF Response	0.5ms
Terminal Type (included)	Removable (D4-16IOCON)
Status Indicators	Logic side
Weight	9.5oz. (270g)
Fuses	1 (5A) per common Non-replaceable

See page 6-57 for part numbers of ZIPLink cables and connection modules compatible with this I/O module.



D4-16TD2 DC Output <--->	
Outputs per Module	16 (current sourcing)
Commons per Module	2 (isolated)
Operating Voltage	10.2-26.4VDC
Output Type	NPN Emitter Follower
Peak Voltage	40VDC
ON Voltage Drop	1.5VDC @ 0.5A
Max Current (resistive)	0.5A/point 3A/common @ 50° C 2.5A/common @ 60° C
Max Leakage Current	0.1mA @ 40VDC
Max Inrush Current	2A for 10ms 1A for 100ms
Minimum Load	0.2mA
Base Power Required 5V	400mA max
External DC Required	None
OFF to ON Response	1ms
ON to OFF Response	1ms
Terminal Type (included)	Removable (D4-16IOCON)
Status Indicators	Logic side
Weight	9.8oz. (280g)
Fuses	1 (5A) per common Non-replaceable

See page 6-57 for part numbers of ZIPLink cables and connection modules compatible with this I/O module.

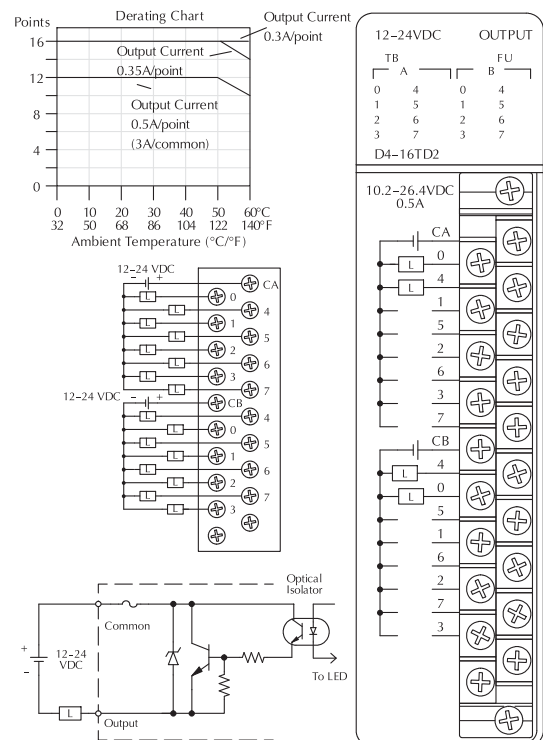
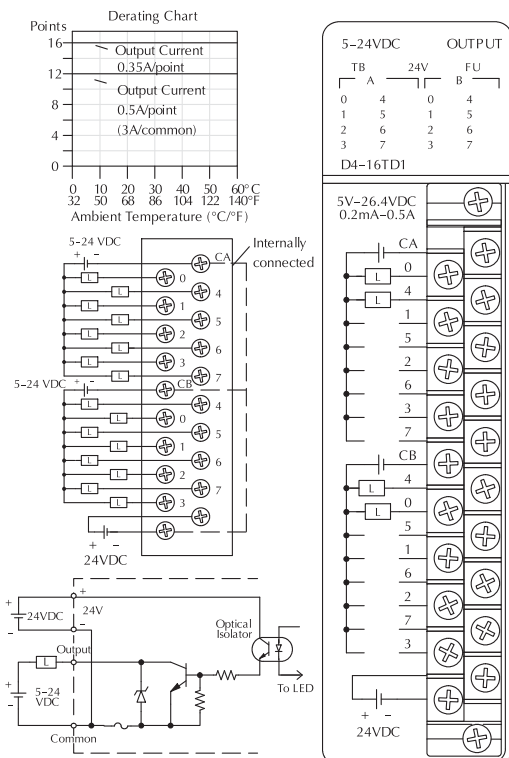

Cut PLC wiring time to minutes instead of hours

The ZIPLink wiring system eliminates the normally tedious process of wiring PLC I/O to terminal blocks. Simply plug one end of a ZIPLink pre-wired terminal block cable into your I/O module and the other end into a ZIPLink connector module. It's that easy. ZIPLinks use half the space, at a fraction of the total cost of terminal blocks.

ZIPLinks are available in a variety of styles to suit your needs, including fused, relay and sensor/LED connector modules. ZIPLinks are available for all DL405 Series PLC discrete and analog input and output modules.

For complete information see ZIPLinks in the Terminal Blocks and Wiring Solutions section.



Specify your ZIPLink system

Use the Compatibility Matrix table below:

Step 1	Locate the I/O module part number.
Step 2	Locate Connector Module Type. (Feedthrough Module, Fuse Module, etc...)
Step 3	Select the cable length by replacing the # symbol with: Blank = 0.5m, -1 = 1.0m, -2 = 2.0m ¹
Note: Cable part number denotes compatibility between Connector Module and I/O Modules.	

ZipLink Wiring System Compatibility Matrix for DL405 PLCs										
Step 2: Connector Module Type		Feedthrough Modules		Fuse Modules		Relay Modules	Sensor Input Modules		Pigtail Cable	
Step 1: I/O Module	Number of Terminals	ZL-RTB20	ZL-RTB40	ZL-RFU20	ZL-RFU40	ZL-RRL16-24	ZL-LTB16-24	ZL-LTB32-24		
Step 3: Cables										
Inputs										
I/O Module	D4-08ND3S	20	ZL-D4-CBL20#							
	D4-16ND2	20	ZL-D4-CBL20#				ZL-D4-CBL20#			
	D4-16ND2F	20	ZL-D4-CBL20#				ZL-D4-CBL20#			
	D4-32ND3-1	40		ZL-D24-CBL40#				ZL-D24-CBL40#	ZL-D24-CBL40#P	
	D4-32ND3-2	40		ZL-D24-CBL40#				ZL-D24-CBL40#	ZL-D24-CBL40#P	
	D4-64ND2*	40		ZL-D24-CBL40#				ZL-D24-CBL40#	ZL-D24-CBL40#P	
	D4-08NA**	11								
	D4-16NA	20	ZL-D4-CBL20#							
	D4-16NA-1	20	ZL-D4-CBL20#							
	D4-16NE3	20	ZL-D4-CBL20#					ZL-D4-CBL20#		
	F4-08NE3S	20	ZL-D4-CBL20#							
	Outputs									
	D4-08TD1**	11								
	F4-08TD1S**	20								
	D4-16TD1	20	ZL-D4-CBL20#		ZL-D4-CBL20#					
	D4-16TD2	20	ZL-D4-CBL20#		ZL-D4-CBL20#					
D4-32TD1	40		ZL-D24-CBL40#		ZL-D24-CBL40#				ZL-D24-CBL40#P	
D4-32TD1-1	40		ZL-D24-CBL40#		ZL-D24-CBL40#				ZL-D24-CBL40#P	
D4-32TD2	40		ZL-D24-CBL40#		ZL-D24-CBL40#				ZL-D24-CBL40#P	
D4-64TD1*	40		ZL-D24-CBL40#		ZL-D24-CBL40#				ZL-D24-CBL40#P	
D4-08TA**	11									
D4-16TA	20	ZL-D4-CBL20#		ZL-D4-CBL20#						
D4-08TR**	11									
F4-08TRS-1****	20	ZL-D4-CBL20#								
F4-08TRS-2****	20	ZL-D4-CBL20#								
D4-16TR***	20	ZL-D4-CBL20#		ZL-D4-CBL20#						

* The D4-08ND2 and D4-64TD1 modules have two 32-point connectors and require 2 ZIPLink cables and 2 ZIPLink connector modules.

** These modules are not supported by the ZIPLink wiring system.

*** Caution: The D4-16TR relay outputs are derated not to exceed 2 Amps per point and 4 Amps per common when used with the ZIPLink wiring system.

**** The F4-08TRS-1 and F4-08TRS-2 are derated not to exceed 2 Amps per point and 2 Amps per common when used with the ZIPLink wiring system.

ZIPLinks Connector Modules specifications begin on page 26-56

ZIPLinks Cables specifications begin on page 26-74

Check the Power Budget

Verify your power budget requirements

Your I/O configuration choice can be affected by the power requirements of the I/O modules you choose. When determining the types and quantity of I/O modules you will be using, it is important to remember there is a limited amount of power available from the power supply.

The chart on the opposite page indicates the power supplied and used by each DL405 device. The adjacent chart shows an example of how to calculate the power used by your particular system. These two charts should make it easy for you to determine if the devices you have chosen fit within the power budget of your system configuration.

If the I/O you have chosen exceeds the maximum power available from the power supply, you can resolve the problem by shifting some of the modules to an expansion base or remote I/O base (if you are using remote I/O).

Warning: It is extremely important to calculate the power budget correctly. If you exceed the power budget, the system may operate in an unpredictable manner which may result in a risk of personal injury or equipment damage.

Use ZIPLinks to reduce power requirements

If your application requires a lot of relay outputs, consider using the ZipLink AC or DC relay output modules. These modules can switch high current (10A) loads without putting a load on your base power budget. Refer to page 6-57 for more information.

This logo is placed next to I/O modules that are supported by the ZIPLink connection systems. See the I/O module specifications at the end of this section.



Calculating your power usage

The following example shows how to calculate the power budget for the DL405 system. The example is constructed around a single 8-slot base using the devices shown. It is recommended you construct a similar table for each base in your system.

A			
Base Number	Device Type	5 VDC (mA)	External 24 VDC Power (mA)
B CURRENT SUPPLIED			
CPU/Expansion Unit /Remote Slave	D4-440 CPU	3700	400
C CURRENT REQUIRED			
SLOT 0	D4-16ND2	+150	+0
SLOT 1	D4-16ND2	+150	+0
SLOT 2	F4-04DA	+120	+100
SLOT 3	D4-08ND3S	+100	+0
SLOT 4	D4-08ND3S	+100	+0
SLOT 5	D4-16TD2	+100	+0
SLOT 6	D4-16TD2	+100	+0
SLOT 7	D4-16TR	+1000	+0
D OTHER			
BASE	D4-08B	+80	+0
Handheld Programmer	D4-HPP	+320	+0
E Maximum Current Required		2820	100
F Remaining Current Available		3700-2820=880	400-100=300
1. Using a chart similar to the 3 one above, fill in column 2. 2. Using the tables on the opposite page, enter the current supplied and used by each device (columns 3 and 4). Pay special attention to the current supplied by the CPU, Expansion Unit, and Remote Slave since they differ. Devices which fall into the "Other" category (Row D) are devices such as the Base and the Handheld programmer, which also have power requirements, but do not plug directly into the base. 3. Add the current used by the system devices (columns 3 and 4) starting with Slot 0 and put the total in the row labeled "maximum current required" (Row E). 4. Subtract the row labeled "Maximum current required" (Row E), from the row labeled "Current Supplied" (Row B). Place the difference in the row labeled "Remaining Current Available" (Row F). 5. If "Maximum Current Required" is greater than "Current Supplied" in either column 3 or 4, the power budget will be exceeded. It will be unsafe to use this configuration and you will need to restructure your I/O configuration. Note the auxiliary 24 VDC power supply does not need to supply all the external power. If you need more than the 400mA supplied, you can add an external 24VDC power supply. This will help keep you within your power budget for external power.			

DL405 CPU power supply specifications and power requirements

Specification	AC Powered Units	24 VDC Powered Units	125 VDC Powered Units
Part Numbers	D4-450, D4-440, D4-430, D4-EX (expansion base unit), D4-RS (remote slave unit)	D4-450DC-1, D4-440DC-1, D4-EXDC (expansion base unit), D4-RSDC (remote slave unit)	D4-450DC-2, D4-440DC-2
Voltage Withstand (dielectric)	1 minute @ 1,500 VAC between primary, secondary, field ground, and run relay		
Insulation Resistance	> 10MΩ at 500VDC		
Input Voltage Range	85-132 VAC (110 range) 170-264 VAC (220 range)	20-28 VDC (24 VDC) with less than 10% ripple	90-146 VDC (125 VDC) with less than 10% ripple
Maximum Inrush Current	20 A	20 A	20 A
Maximum Power	50 VA	38 W	30 W

Power Requirements

Power Supplied					
CPUs/Remote Units/ Expansion Units	5 VDC Current Supplied in mA	24V Aux Power Supplied in mA	CPUs/Remote Units/Expansion Units	5V Current Supplied in mA	24VAux. Power Supplied in mA
D4-430 CPU	3700	400	D4-EX	4000	400
D4-440 CPU	3700	400	D4-EXDC	4000	NONE
D4-440DC-1 CPU	3700	NONE	D4-EXDC-2	3700	NONE
D4-440DC-2 CPU	3700	NONE	D4-RS	3700	400
D4-450 CPU	3100	400	D4-RSDC	3700	NONE
D4-450DC-1 CPU	3100	NONE	H4-EBC	3470	400
D4-450DC-2 CPU	3100	NONE	H4-EBC-F	3300	400
Power Consumed					
Power-consuming Device	5V Current Consumed	External 24VDC Current Required	Power-consuming Device	5V Current Consumed	External 24VDC Current Required
I/O Bases			Analog Modules (continued)		
D4-04B-1	80	NONE	F4-16AD-1	75	100
D4-06B-1	80	NONE	F4-16AD-2	75	100
D4-08B-1	80	NONE	F4-04DA-1	70	75+20per circuit
			F4-04DA-2	90	90
			F4-04DAS-1	60	60 per circuit
			F4-04DAS-2	60	60 per circuit
			F4-08DA-1	90	100+20 per circuit
			F4-08DA-2	80	150
			F4-16DA-1	90	100+20 per circuit
			F4-16DA-2	80	25 max.
			F4-08RTD	80	NONE
			F4-08THM-n	120	50
			F4-08THM	110	60
DC Input Modules			Remote I/O		
D4-08ND3S	100	NONE	H4-ERM	320	NONE
D4-16ND2	150	NONE	H4-ERM-F	450	NONE
D4-16ND2F	150	NONE	D4-RM	300	NONE
D4-32ND3-1	150	NONE			
D4-32ND3-2	150	NONE			
D4-64ND2	300 max.	NONE			
AC Input Modules			Communications and Networking		
D4-08NA	100	NONE	H4-ECOM100	300	NONE
D4-16NA	150	NONE	H4-ECOM	530	NONE
			H4-ECOM-F	670	NONE
			D4-DCM	500	NONE
			F4-MAS-MB	235	NONE
			FA-UNICON	NONE	65
AC/DC Input Modules			CoProcessors		
D4-16NE3	150	NONE	F4-CP128-1	305	NONE
F4-08NE3S	90	NONE			
DC Output Modules			Specialty Modules		
D4-08TD1	150	35	H4-CTRIO	400	NONE
F4-08TD1S	295	NONE	D4-INT	100	NONE
D4-16TD1	200	125	D4-HSC	300	NONE
D4-16TD2	400	NONE	F4-16PID	160	NONE
D4-32TD1	250	140	F4-8MPI	225	170
D4-32TD1-1	250	140 (15V)	D4-16SIM	150	NONE
D4-32TD2	350	120 (4A max including loads)	F4-4LTC	280	75
D4-64TD1	800	NONE			
AC Output Modules			Programming		
D4-08TA	250	NONE	D4-HPP-1 (Handheld Prog.)	320	NONE
D4-16TA	450	NONE			
Relay Output Modules			Operator Interface		
D4-08TR	550	NONE	DV-1000	150	NONE
F4-08TRS-1	575	NONE			
F4-08TRS	575	NONE			
D4-16TR	1000	NONE			
Analog Modules			C-more Micro-Graphic		
F4-04AD	85	100			
F4-04ADS	270	120			
F4-08AD	75	90			