

XC-75 series XC-73 series

Component/OEM



OUTLINE

The XC-75/73 series of monochrome camera module has been designed to be a more compact and versatile version of the widely used XC-77 for machine vision application. The XC-75/73 has an asynchronous trigger shutter function (S-DONPISHA) that allows fast moving objects to be captured upon the application of an external signal. The XC-75/73 series has been made even more versatile by the introduction of the L-type frame. This enables installation systems where space is a premium without using a mirror.

FEATURES

- XC-75/75L/75CE : 1/2" IT Hyper HAD CCD
- XC-73/73L/73CE : 1/3" IT Hyper HAD CCD
- High resolution
Horizontal resolution 570TV lines/560TV lines
- Compact and lightweight
- 2 : 1 Interlaced/Non-Interlaced
- Frame/Field exposure
- High sensitivity 400 lx, F4
- High S/N ratio 56dB/54dB
- Electronic shutter function (8steps 1/125~1/10,000sec.)
- External trigger shutter (S-DONPISHA) function
- HD/VD, VS external sync.
- Restart • Reset function
- Compatible with XC-77/77CE

CONNECTIONS

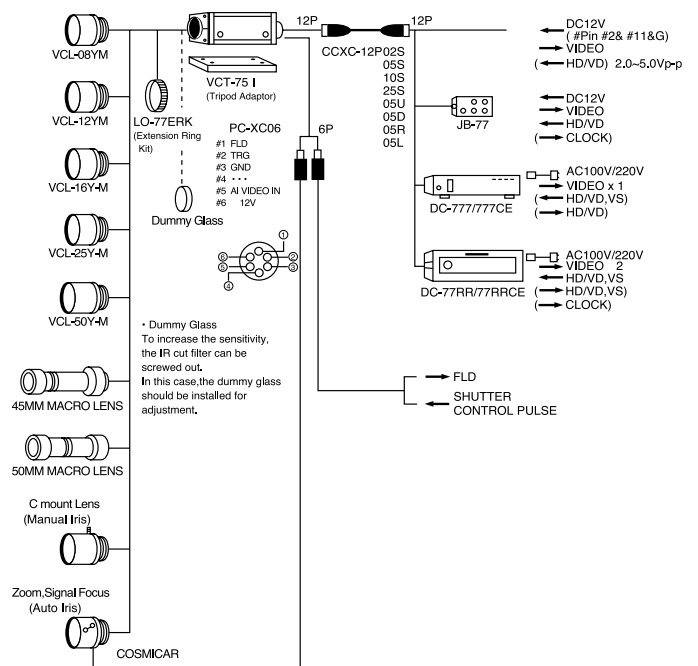

CCD OUTPUT WAVE TIMING CHART

XC-75/75L/75CE

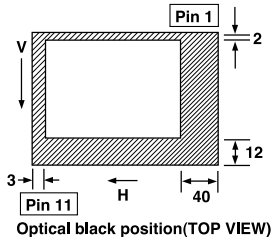

	XC-75/75L	XC-75CE
Optical size	1/2-inch format	
Effective picture elements	768(H) x 494(V)	752(H) x 582(V)
Total number of pixels	811(H) x 508(V)	795(H) x 596(V)
Chip size	7.95mm(H) x 6.45mm(V)	
Unit cell size	8.4μm(H) x 9.8μm(V)	8.6μm(H) x 8.3μm(V)

XC-73/73L/73CE

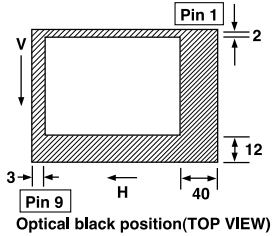

	XC-73/73L	XC-73CE
Optical size	1/3-inch format	
Effective picture elements	768(H) x 494(V)	752(H) x 582(V)
Total number of pixels	811(H) x 508(V)	795(H) x 596(V)
Chip size	6.00mm(H) x 4.96mm(V)	
Unit cell size	6.35μm(H) x 7.4μm(V)	6.5μm(H) x 6.25μm(V)

EIA(XC-75/75L/73/73L)

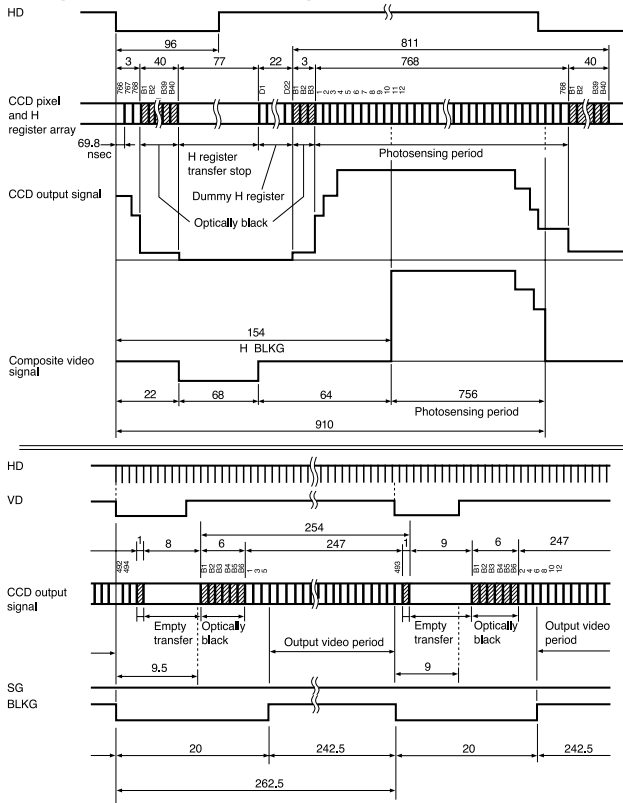

CCIR(XC-75CE/73CE)

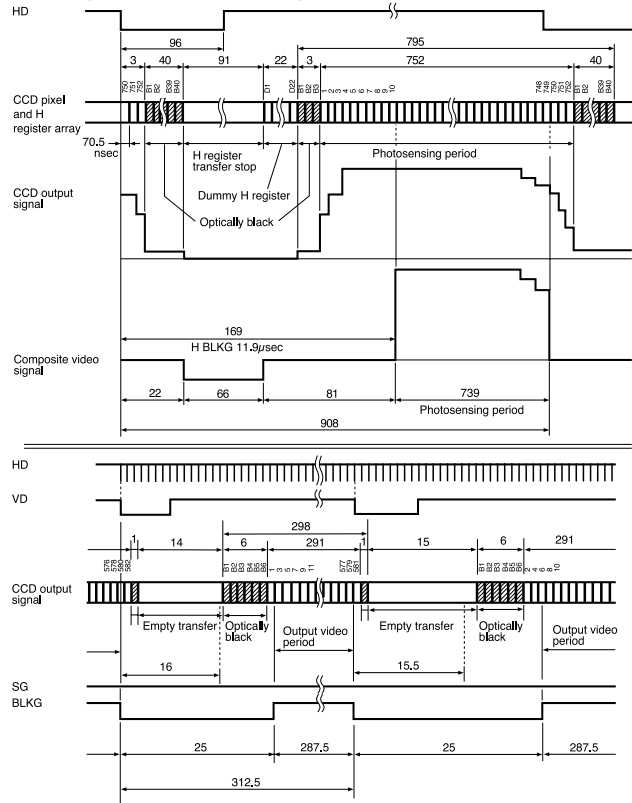

REAR SWITCHES & CONNECTORS

GAIN Switch Manual gain control



★VIDEO OUT connector

12Pin Multiconnector (External view)

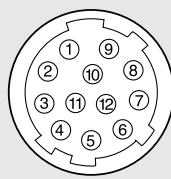

6Pin Lens connector(External view)

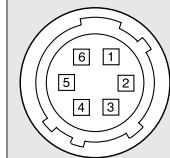

Pin No.	SIGNAL	SPECIFICATION
1	FLD OUT	FLD OUT
2	TRIGGER	TTL level
3	GND	GND
4	NC	NC
5	VS OUT	VIDEO SIGNAL OUTPUT
6	+12 OUT	DC+12 OUT

Pin No.	EXTERNAL SYNC MODE			CAMERA SYNCHRONOUS
	HD / VD	VS	RESTART RESET	OUTPUT
1	GND	GND	GND	GND
2	DC+12V	DC+12V	DC+12V	DC+12V
3	VIDEO OUTPUT(GND)	VIDEO OUTPUT(GND)	VIDEO OUTPUT(GND)	VIDEO OUTPUT(GND)
4	VIDEO OUTPUT(SIGNAL)	VIDEO OUTPUT(SIGNAL)	VIDEO OUTPUT(SIGNAL)	VIDEO OUTPUT(SIGNAL)
5	HD INPUT(GND)	—	HD INPUT(GND)	HD OUTPUT(GND)
6	HD INPUT(SIGNAL)	—	HD INPUT(SIGNAL)	HD OUTPUT(SIGNAL)
7	VD INPUT(SIGNAL)	VS INPUT(SIGNAL)	RESET PULSE(SIGNAL)	VD OUTPUT(SIGNAL)
8	—	—	—	CLOCK OUTPUT(GND)
9	—	—	—	CLOCK OUTPUT(SIGNAL)
10	GND	GND	GND	GND
11	DC+12V	DC+12V	DC+12V	DC+12V
12	VD INPUT(GND)	VS INPUT(GND)	RESET PULSE(GND)	VD OUTPUT(GND)

★ When the pin No.4 of the 12Pin connector is not terminated with 75 Ω impedance, you can only use this connector for video signal output.

OPERATION MODE SETTING

● REAR PANEL

Item	Location	Setting	Factory-setting mode
GAIN mode(*1)	Rear Panel	SLIDE SW	F(0dB)
MAN.gain control	Rear Panel	VOLUME	0dB

● INTERNAL of CAMERA

Item	Location	Setting	Factory-setting mode
γ correction mod(*2)	PR-165 board	JR1, JR2	OFF
Normal shutter	MB-403 board	SW S1	0(OFF)
S-DONPISHA	MB-403 board	JR1	OPEN(OFF)
Trigger setting	MB-403 board	JR2	OPEN(OFF)
Charge accumulation mode(*3)	MB-403 board	JR3	OPEN(FRAME)
Sync signal input/output(*4) EXT/INT-HD/VD	SG-199 board	SW S1	E(INPUT)
EXTHD75 Ω termination(*5)	SG-199 board	SW S2	ON
EXTVD75 Ω termination	SG-199 board	SW S3	ON
RESTART • RESET mode	SG-199 board	JR7, JR8	SHORT(OFF)
Clock signal output(*6)	CN-649 board	JR1	OPEN

(*1) ● GAIN mode: "A"(AGC) is automatically adjusted to the proper level between 0 and 18 dB according to the brightness of a subject. "F" (fixed) is fixed to 0 dB. "M"(manual) can be adjusted between 0 and 18 dB when no proper illuminance can be obtained. Recommend the use of "F" or "M" for image processing.

(*2) ● γ correction mode: Set this mode to OFF if accurate video information for image processing is required. If the γ correction mode is set to ON, the display on the monitor screen is correct. The γ correction value at that time is approximately 0.45.

(*3) ● Charge storage mode: For frame storage, a still subject can be shot by high resolution (H/V). For field storage, an image can be shot in units of fields. The field storage is thus suitable for a moving subject.

(*4) ● Sync signal input/output: The camera is automatically detects when an external sync signal is input to the camera during factory setting.

To output a sync signal from the camera, set to "1" (output).

● Comparison with FRAME and FIELD accumulation

Read out mode setting		Frame integration mode		Field integration mode	
Scanning mode		Interface	Non-Interface	Interface	Non-Interface
Scanning	NORMAL MODE				
	INVERSE MODE	FLD 1 and FLD 2 are inverted.	FLD 1 and FLD 2 become ② ③ ④...	FLD 1 and FLD 2 are inverted.	FLD 1 and FLD 2 become ② ③ ④...
Storage time and VIDEO OUT correlation					
Vertical effective lines(TV lines)	EIA	492	242	350	242
	CCIR	582	291	410	291

(*5) ● 75 Ω termination: This switch is set to ON at the factory. Notice that some user systems may not be able to be connected unless this switch is set to high impedance. This switch is set to high impedance when the factory setting is changed from ON to OFF.

(*6) ● Clock output mode: A horizontal drive frequency of the CCD can be output in the clock output mode. Short-circuit JR1 when an accurate data exchange is required between an image processing system and this mode.

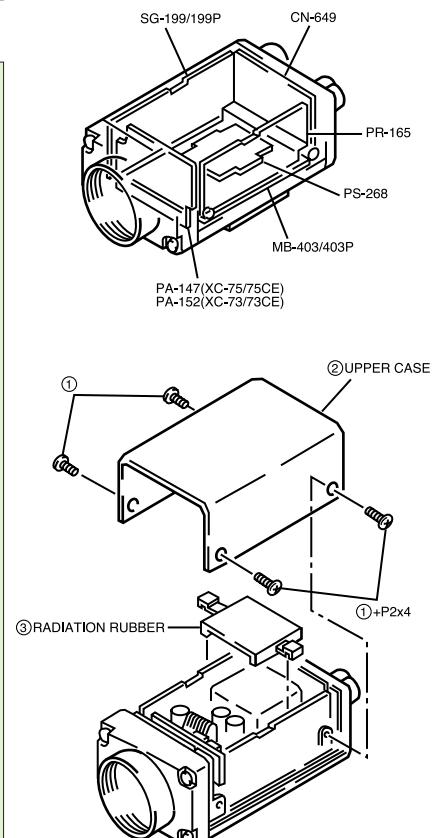
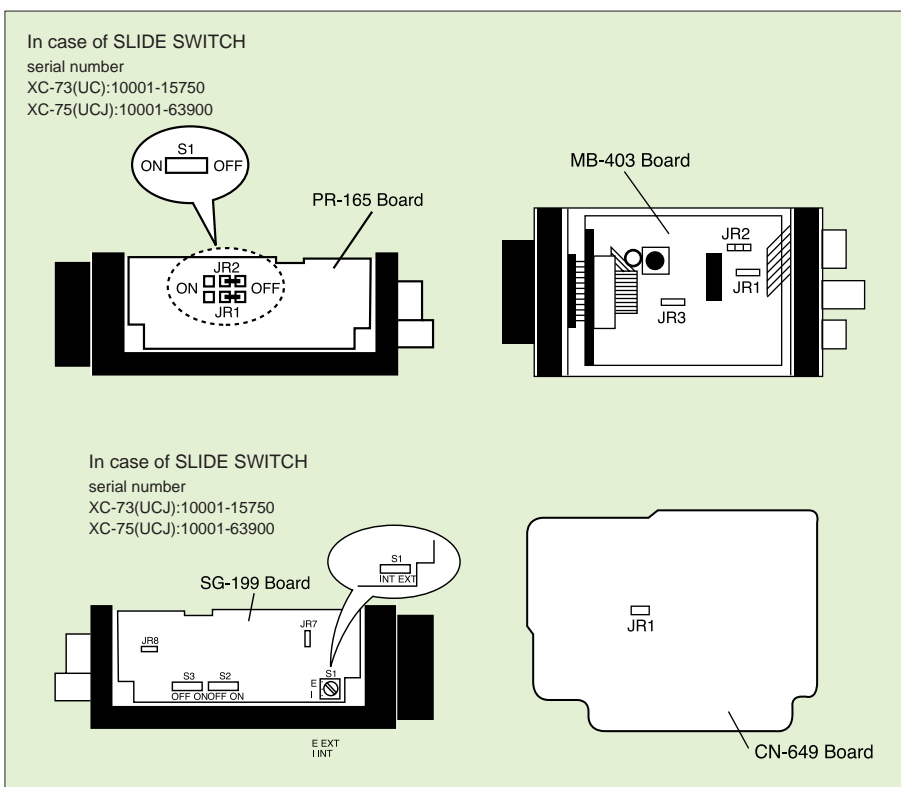

SHUTTER FUNCTIONS (NORMAL SHUTTER)

The electronic shutter mode continuously capture clear images of fast moving objects. The shutter speed is set using a rotary switch (S1) on the MB-403 board. It is recommended to use of field accumulation mode to improve sensitivity.

MB-403 Board S1(Shutter speed can be set through this hole using a 2mm screwdriver)

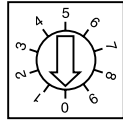
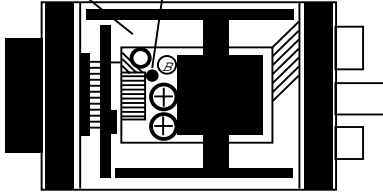

Switch S1
MB-403 board
Factory setting

Position	Shutter speed
0	OFF
1	1/125
2	1/250
3	1/500
4	1/1000
5	1/2000
6	1/4000
7	1/10000
8	Flicker-less mode*
9	Flicker-less mode*

* The flicker-less mode can be set when the rotary code switch is set to position 8 or 9. In positions 8 and 9, the shutter speed is 1/100sec for EIA, and 1/120 sec for CCIR.

Confirmation of Electronic Shutter OFF Position while Monitoring

À@Condition:Fix the lens iris.

Turn the rotary switch S1 on the MB-403 board clockwise and stop it when the image is brightest on the monitor. This detect position is the Shutter OFF position.

SHUTTER FUNCTIONS (TRIGGER SHUTTER S-DONPISHA)

A fast moving object can be captured precisely by an external trigger input. In addition to the trigger input, a continuous EXT HD signal and one VD pulse are required when this mode is set. It is necessary to change the mode internal setting of camera.

Internal setting of camera SG-199 board JR7, JR8 → open(same as Restart • Reset mode)

MB-403 board JR1 → short, JR2 → short (TR), JR3 → short

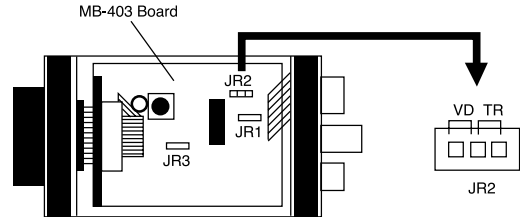
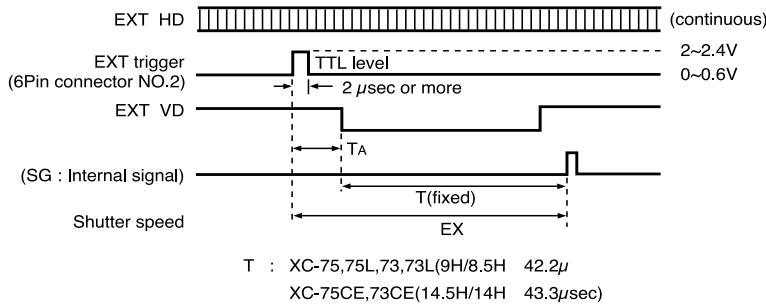

EX:The shutter speed can be controlled by trigger and VD pulses. The exposure time: EX=TA(variable)+T(fixed)

An accurate shutter speed with high repeatability can be obtained by synchronizing trigger and HD pulses.

shutter speed XC-75, 73, 75L, 73L 1/100~1/1,600 sec.
XC-75CE, 73CE 1/80~1/1,500 sec.

RESTART•ERESSET

In the external sync mode, the information corresponding to one screen can be captured randomly.

Internal setting of camera JR7 and J8 on SG-199 board → open

An external sync signal is required when this mode is set. The external sync signal can be output when a continuous HD signal is added to pin 6 (HD signal) of a 12-pin connector and when an RR signal is added to pin 7 (VD signal).

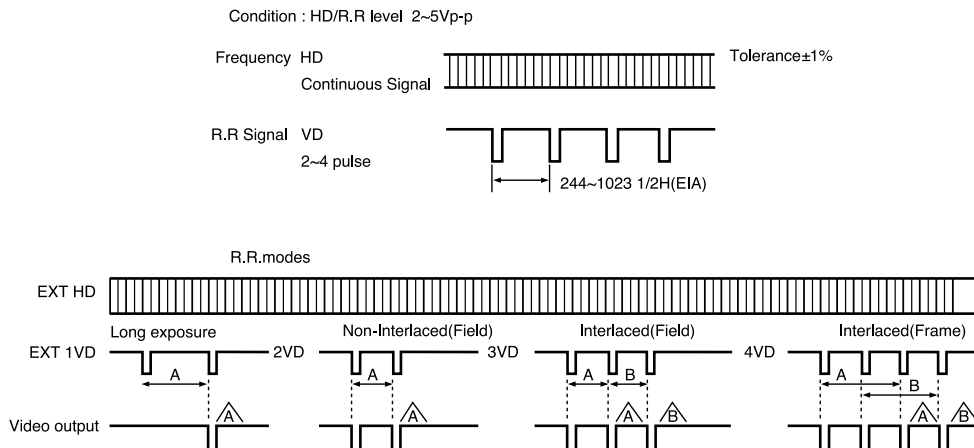

DIMENSIONS

- XC-75/75CE
- XC-73/73CE

unit : mm



44(W) x 29(H) x 71(D)mm
140g

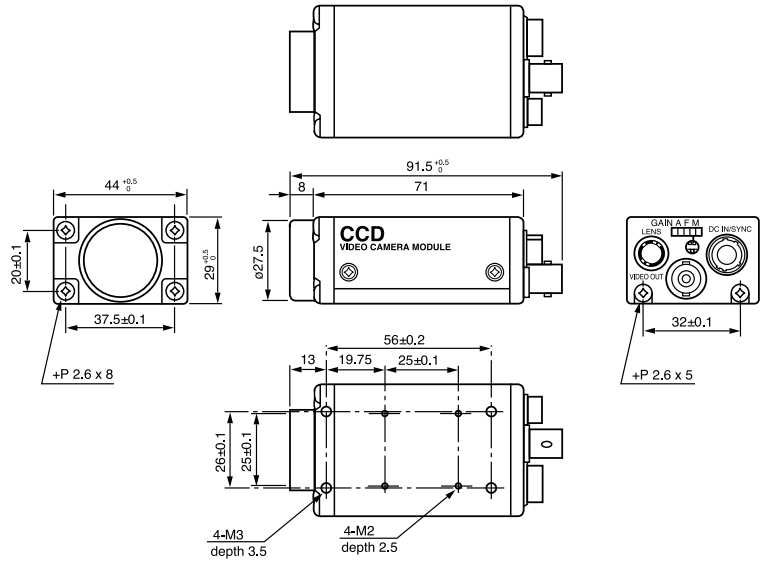

- XC-75L
- XC-73L



44(W) x 29(H) x 93.5(D)mm
180g

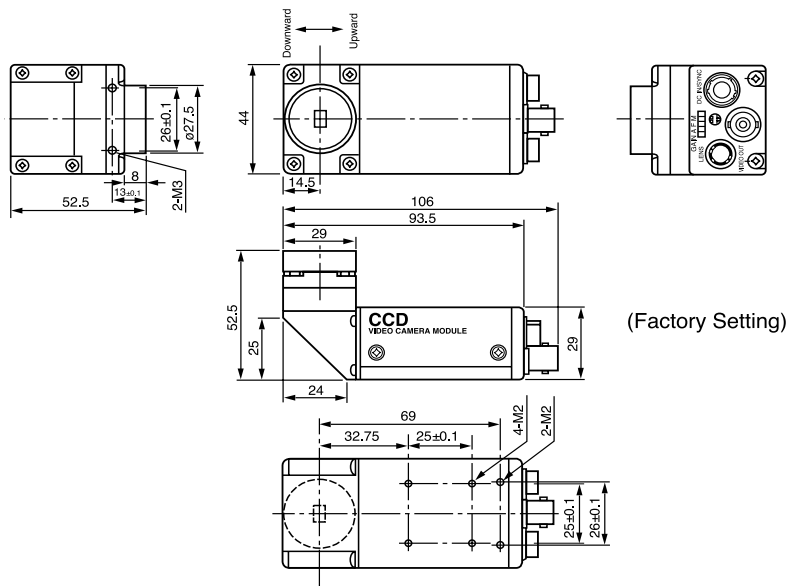

PROCEDURE TO CHANGE THE DIRECTION OF THE OPTICAL LENS PART(only XC-75L/73L)

1.Remove the FRONT PANEL.

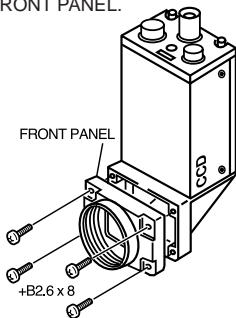

2.Disconnect the connector CN1 on the PA board.

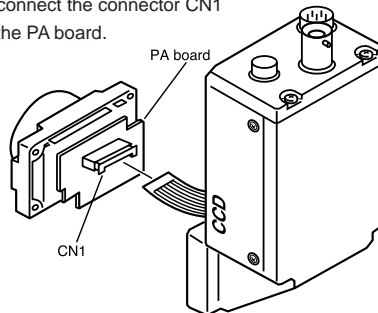

3.Remove the L-angle.

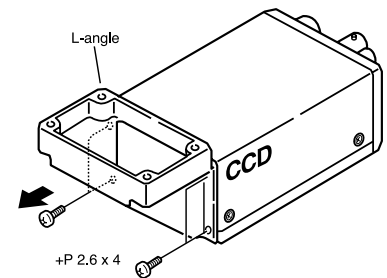

4.Turn the L-angle upside down, and assemble.

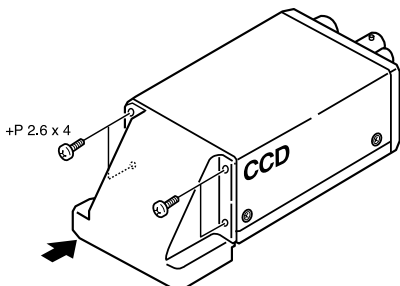

5.Connect the flexible harness to CN1 on the PA board. Be sure to confirm the direction of FRONT PANEL.

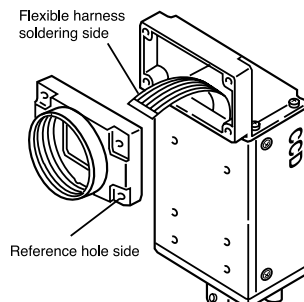

6.Assemble the FRONT PANEL.

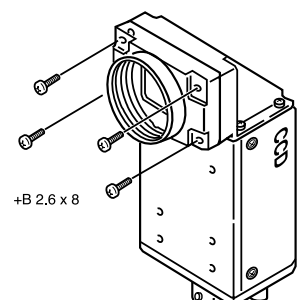

SPECIFICATIONS

	XC-75/75L/73/73L	XC-75CE/73CE
Pick up device	Interline transfer Hyper HAD CCD	
Effective picture elements	768(H) x 494(V)	752(H) x 582(V)
CCD horizontal frequency	14.318MHz	14.1875MHz
Signal system	EIA	CCIR
Lens mount	C mount	
Flange back	17.526mm±0.05	
Horizontal frequency	15.734KHz	15.625KHz
Vertical frequency	59.94Hz	50Hz
Sync System	Internal/External(auto)	
External sync system	HD/VD(2~5Vp-p), S, VS(SYNC: 0.3 ^{+0.3} _{0.15} Vp-p)	
External sync frequency	Horizontal sync frequency±1%	
Jitter	less than±50n sec.	
Scanning system	525 lines 2:1Interlaced/Non-Interlaced	625 lines 2:1Interlaced/Non-Interlaced
Video output	1.0Vp-p, negative, 75 Ω unbalanced	
Horizontal resolution	570 TV lines	560 TV lines
Sensitivity	400 lx F4(γ compensation ON, 0dB)	
Minimum illumination	3.0 lx(AGC, F1.4, γ compensation ON)(with IR cut filter)/approx. 0.5 lx(without IR cut filter)	
S/N ratio	56dB	54dB
Gain	AGC(O~18dB)/ FIX(0dB)/Manual(0~18dB)	
Gamma	γ : ON(γ =0.45)/OFF(γ =1) (Internal switch selection)	
Normal shutter	FL, 1/125, 1/250, 1/500, 1/1,000, 1/2,000, 1/4,000, 1/10,000 sec.	
Trigger shutter (S-DONPISHA)	1/100~1/1,600 sec.	1/80~1/1,500 sec.
Power requirements	DC+12V(+10.5~15V)	
Power consumptions	XC-75, 75L, 75CE:1.6W /XC-73, 73L, 73CE:1.4W	
Weight	XC-75, 75CE, 73, 73CE:140g /XC-75L, 73L:180g	
Operating temp./mois.	-5~+45°C/20~80%	
Storage temp./mois.	-25~+60°C/20~95%	
Vibration resistance	7G(11~200Hz XYZ directions)	
Shock resistance	70G	
MTBF	123,900Hrs	
Regulations	UL1409, FCC Class A Digital Device,CE(EN50081-1+EN50082-1(excluding XC-75L/73L))	
Supplied accessories	Lens mount cap(1), Operating instructions(1)	

CHARACTERISTICS

● Total MTF Response(typical value)

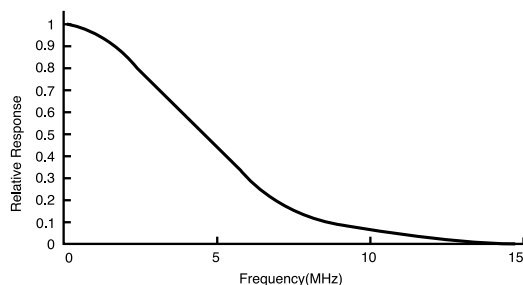

● Spectral Response(typical value)

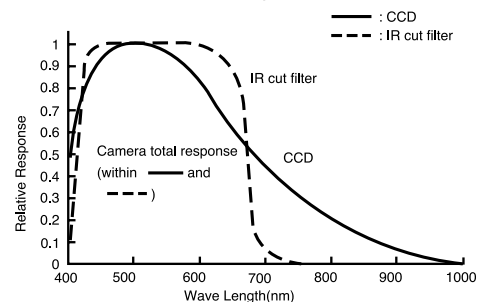

● Sony Electronics Inc. ISP(USA)

Itasca Office
San Jose Office
Park Ridge Office

1200 N. Arlington Heights Rd, MD-1118 Itasca, IL 60143-1291
3300 Zanker Rd, MS-SJ2B1 San Jose, CA 95134-1901
1 Sony Drive Park Ridge, NJ 07645

(TEL:+1-630-773-7604)

(FAX:+1-630-773-7605)

(TEL:+1-408-955-5623)

(FAX:+1-408-955-5630)

(TEL:+1-201-358-4173)

(FAX:+1-201-358-4401)

(TEL:+1-416-499-1414)

(FAX:+1-416-497-1774)

● Sony of Canada Ltd.(CANADA)

● Sony Broadcast & Professional Europe

HQ
Germany
France
UK
Nordic
Italy

15, rue Floreal 75831 Paris Cedex 17, France
Hugo-Eckener-Str. 20, 50829 Koln
15, rue Floreal 75831 Paris Cedex 17
The Heights, Brooklands, Weybridge, Surrey KT13 0XW
Per Albin Hanssons vag 20 S-214 32 Malmo Sweden
Via Galileo Galilei 40 I-20092 Cinisello Balsamo, Milano
4-16-1 Okata, Atsugi-shi, Kanagawa-ken, 243

(TEL:+33-1-40-87-35-11)

(FAX:+33-1-40-87-35-17)

(TEL:+49-221-5966-322)

(FAX:+49-221-5966-491)

(TEL:+33-1-49-45-41-62)

(FAX:+33-1-47-31-13-57)

(TEL:+44-990-331122)

(FAX:+44-1932-817011)

(TEL:+46-40-190-800)

(FAX:+46-40-190-450)

(TEL:+39-2-618-38-431)

(FAX:+39-2-618-38-402)

(TEL:+81-462-27-2345)

(FAX:+81-462-27-2347)

● Sony Corp. ISC Co. APP Sales Dpt.(JAPAN)