



# Instruction Bulletin

Bulletin: 30598-282-01C1

Date: September, 1989

## SY/MAX<sup>®</sup>

### CLASS 8030 TYPE RIM-101 16 FUNCTION 120 VAC/DC INPUT MODULE

#### DESCRIPTION

The Type RIM-101 120VAC/DC Input Module contains 16 optically isolated inputs which are capable of handling signals from such field input devices as limit switches, push buttons, and selector switches. The module may be inserted into any slot of a register rack except slot 1 (or slots 17 and 18 of an RRK-300) or the register slot of a digital rack.

Each of the sixteen inputs has a red LED on the front of the module which illuminates when receiving an "ON" signal from the field input device (proper voltage applied to the wiring terminal).

A marking label that fits over the wiring terminals is provided to identify input devices.

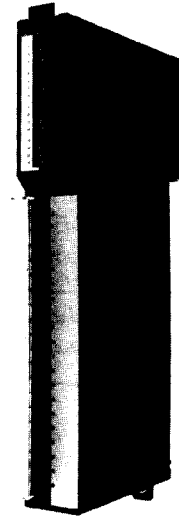

#### SPECIFICATIONS

|   |   |
|---|---|
| Inputs per Module                         | 16  |
| Type of isolation                         | Optical   |
| Isolation rating                          | 2500V RMS   |
| <u>Voltage Characteristics:</u>           |   |
| Voltage Range                             | 90-138VAC at 50/60 Hz. or VDC   |
| Must-turn-on Voltage                      | 90V RMS   |
| Must-turn-off Voltage                     | 30V RMS   |
| <u>Current Characteristics:</u>           |   |
| Input current draw                        | 6mA at 90V and 10mA at 138V   |
| Must-turn-on Current                      | 6mA (at 90V)  |
| Must-turn-off Current                     | 2.0mA (at 25 V)   |
| Rated current draw on SY/MAX Power Supply | 275 mA per module at 75% Duty Cycle<br>300 mA per module at 100% Duty Cycle |
| Input Impedance                           | 14.4K ohms resistive  |
| Turn on Time                              | 8 msec. Nominal   |
| Turn off Time                             | 8 msec. Nominal   |

|                                 |   |
|---------------------------------|---|
| Ambient temperature             | 0 - 60°C  |
| Humidity rating                 | 5 - 95% non-condensing  |
| Weight (unpackaged)             | 2.7 lbs (1.22 kg.)  |
| Detachable Terminal Block       | Class 8030<br>Type CBP-116  |
| Used with these rack assemblies | RRK-100, RRK-200,<br>RRK-300, HRK-100,<br>HRK-150, HRK-200,<br>CRK-210, CRK-300,<br>DRK-210, DRK-300,<br>GRK-110, GRK-210 |

Compatible with Output Modules ROM-221

#### TYPICAL WIRING

Field input devices are wired to the terminal block on the front of the input module. Figure 1 illustrates the typical wiring of the RIM-101 input module.

Wiring terminals 1 through 4 share common terminal "1A," wiring terminals 5 through 8 share common terminal "2A." Likewise, wiring terminals 9 through 12 and 13 through 16 share common terminals "3A" and "4A" respectively. The "B" terminals are not used on the input modules.

## SQUARE D COMPANY

Dedicated to Growth • Committed to Quality

**Note:** Surge suppression is required only when an inductive load is in parallel with a programmable controller input.

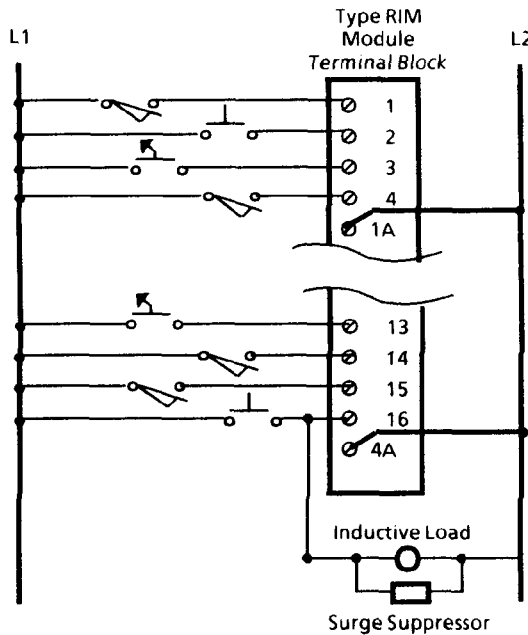

Figure 1 - Typical Wiring

**APPLICATION CONSIDERATIONS**

- Each four inputs sharing a common "A" terminal are electrically isolated from the other group of four inputs on the module.
- By removing the top and bottom retaining screws, the terminal block may be removed from the module, allowing the module to be replaced without disturbing field wiring.
- In those applications where an inductive load such as a motor starter or solenoid is wired in parallel with a Type RIM-101 Input Module, a suppressor must be installed as indicated in Figure 1. A typical suppressor for 120VAC operation consists of a 0.5 mfd. 400 volt capacitor with a 220 ohm resistor in series.
- Note that an "appreciable glow" from the LED may be seen when high leakage current, solid-state input devices are used with a RIM-101, even though the input module is actually off. The must-turn-off voltages and currents are as listed in the specifications.
- If the off-state leakage current of the field input device connected to the Type RIM-101 Input Module is greater than 2mA, consult the factory for recommended signal conditioning.

- When using the Type RIM-101 Input Module with DC voltage inputs, either polarity may be used, for example: Terminal 1 (+) and Terminal 1A (-) or Terminal 1 (-) and Terminal 1A (+).
  - Each terminal will accommodate two #14 gauge wires.
  - Depending on the size and routing of wiring to the I/O terminals, it may be necessary to remove an adjacent terminal strip before removing an I/O module.
  - The LEDs will illuminate "ON" as long as specified input voltages are present at the input terminals, regardless of whether the RIM-101 is plugged into a rack assembly or power is applied to it.
  - When the Type RIM-101 Input Module is located in the same rack as the processor the only processors which will allow the inputs to be forced ON and OFF are the Model 300, 400 and 600 processors. The Model 500 and 700 processors do not support the forcing function. Instead, they rely on the forcing capability in the Local Interface Module to provide this function. Therefore, when the input module is mounted in a remote rack the inputs may be forced ON and OFF by any processor.
  - When using the DISPLAY module of the Class 8010 Type SPR-2XX and SPR-3XX CRT Programmers or SY/MATE\*, all contacts and coils associated with register slot mounted digital I/O modules will be shown with the prefix (R) in front of the address. These (R) designated contacts and coils are associated with actual inputs and outputs and should not be confused with contacts and coils associated with internal relays.
- \*Note:** When using SYM-323 Series B and SYM-324 Series A or later, all contact and coils associated with digital I/O modules will be shown with the prefix (I) in format of the address if it is an input or (O) if it is an output or contact of an external output.

**MODULE KEYING**

Each register slot, whether on a digital or register rack, has two keying pins which are installed at the factory. These are located between slot 4 and 6. They insure only register modules can be plugged into register slots.

Each register slot connector may be keyed to accept only one type of register module. An optional keying pin kit, Class 8030 Type CBP-104, is available for this purpose. The keying pin is manually inserted into the connector using the keying pin insertion tool (see Figure 2). The keying pin location for the Type RIM-101 Input Module is between pins 40 and 42 (see Figure 3).

**CAUTION:** When inserting or removing the keying pins, use care to avoid touching the contact fingers within the connector. Improper insertion or removal may damage the connector.

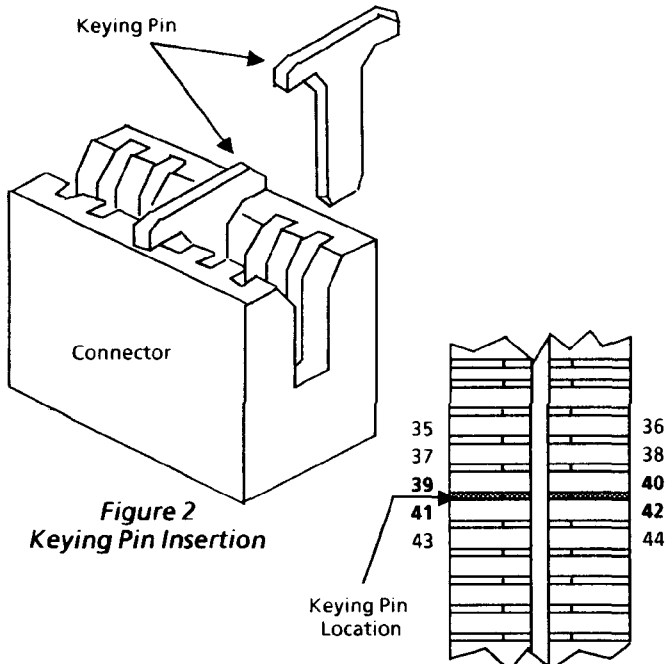

Figure 2  
Keying Pin Insertion

Figure 3  
Module Keying

**INSTALLATION IN A RACK ASSEMBLY**

The Type RIM-101 Input Module may be installed in any register slot of a Class 8030 Type CRK, DRK, GRK, HRK or RRK rack assembly. The module receives 5VDC power and ground from the edge connector at the back of the rack.

Power must be removed from the rack assembly before installing or removing the output module from the rack. After the removal of power, insert the module into the register slot until firmly seated against the stud (the middle post above the socket in that slot). Be sure to tighten the captive screw to insure the module is secured. To remove the module, loosen the captive screw and pull the module out of the slot using the finger tab located on the top of the module.

**Note:** Refer to the Power Supply and Rack Instruction Bulletins to insure proper grounding.

**REGISTER USAGE FOR RACK ADDRESSING**

Each Type RIM-101 Input Module will occupy a single register in the system. When located in a register slot to the right of a Model 500 or Model 700 processor, the RIM-101 must be assigned four registers even though only the first of the four registers is used. The remaining three registers cannot be used.

When mounted in the same rack as a Model 300 processor, a minimum of one register must be assigned to each RIM-101 Input Module. When the Model 300 processor is mounted in an RRK-200 register rack, slot 9 cannot be used for any digital I/O modules. Slot 9 cannot be addressed by the Model 300, therefore, it may be used to power any register module which requires only power and which does not require registers, such as the D-LOG or SY/NET modules.

Slots 17 and 18 on an RRK-300 (lower, right-most slots) are non-addressable by any SY/MAX processor, and therefore, the RIM-101 cannot be used in these slots.

**SIMPLIFIED SCHEMATIC**

Figures 4 and 5 illustrate one of the 16 circuits within the Type RIM-101 Input Module. The terminal marked "1A" is common to the first four inputs within the module.

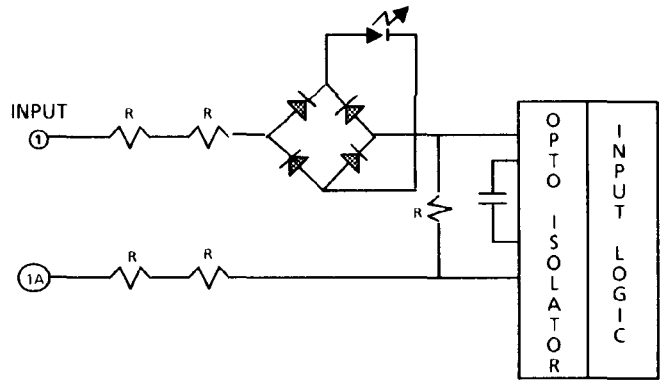

Figure 4 - Simplified Schematic of One Output Circuit (Series A and B)

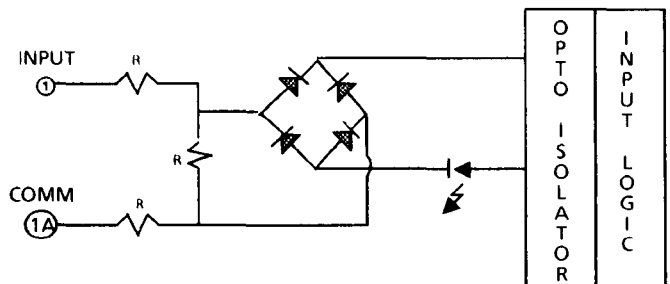

Figure 5 - Simplified Schematic of One Output Circuit (Series C)